

(No Model.)

2 Sheets—Sheet 1.

A. F. MASE.

AUTOMATIC FLOUR BOLT CLEANER.

No. 301,251.

Patented July 1, 1884.

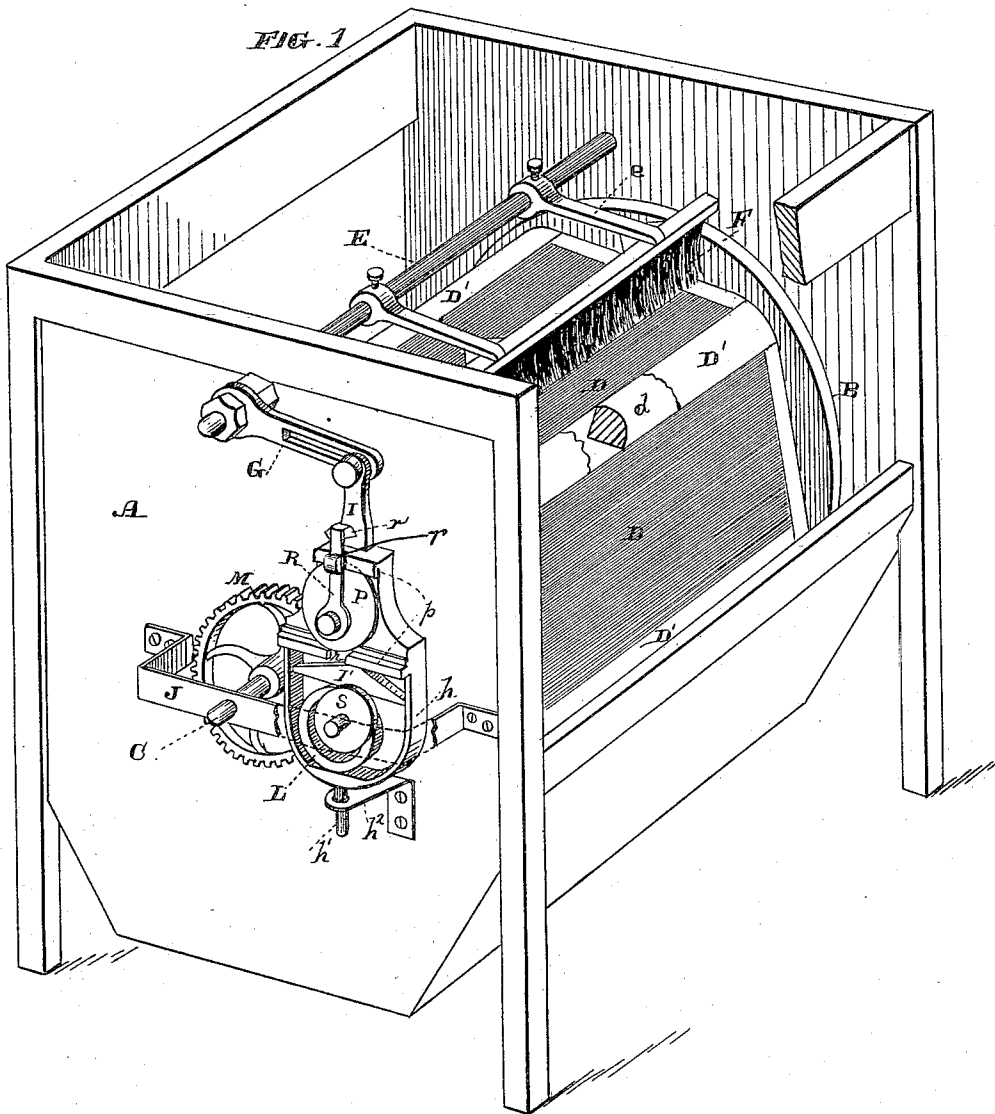

Witnesses,

Geo. H. Strong
J. T. House

Inventor,

A. F. Mase
By Dewey & Co.
Attorneys

A. F. MASE.

AUTOMATIC FLOUR BOLT CLEANER.

No. 301,251.

Patented July 1, 1884.

FIG. 2.

FIG. 3.

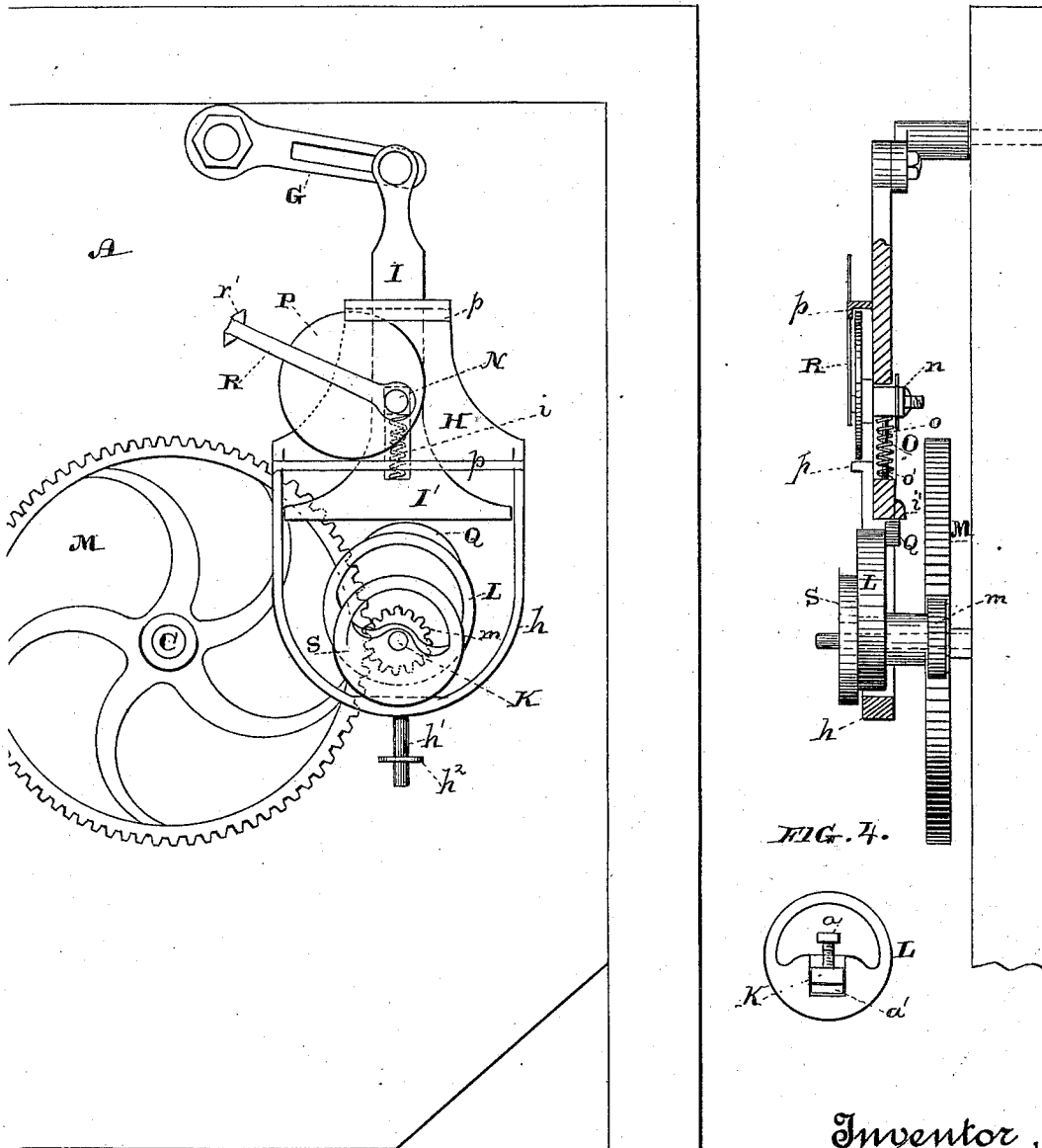

Witnesses,
Geo. H. Strong.
J. H. ...

Inventor,
A. F. Mase
 By
Dewey & Co.
 Attorneys

UNITED STATES PATENT OFFICE.

ALBERT F. MASE, OF SOUTH VALLEJO, CALIFORNIA.

AUTOMATIC FLOUR-BOLT CLEANER.

SPECIFICATION forming part of Letters Patent No. 301,251, dated July 1, 1884.

Application filed February 7, 1884. (No model.)

To all whom it may concern:

Be it known that I, ALBERT F. MASE, of South Vallejo, county of Solano, and State of California, have invented an Improvement in Automatic Flour-Bolt Cleaners; and I hereby declare the following to be a full, clear, and exact description thereof.

My invention relates to that class of devices for cleaning the reels of flour-bolts in which a brush is suspended over and its bristles come in contact with the exterior of the reel; and my invention consists in the novel arrangement and combination of devices, to be hereinafter explained, and pointed out in the claims.

The means for supporting the brush, the mechanism for connecting it with the driving-power to accomplish its action, the means for throwing it out of gear, and the means for preventing undue wear of the gearing all form part of my invention, and will be fully explained.

The reels of flour-bolts are made polygonal, some having six, others eight, and others more or fewer sides, which are composed of fine silk stretched over ribs at the angles, on which lines, for the purpose of preventing wear, ticking strips are secured. When the flour is at all damp, the mesh of the silk becomes clogged, and it is necessary to keep it brushed to permit it to perform its function. Various means are employed to accomplish this result, among which is an overhanging brush adapted to come in contact with the exterior surface of the silk. In some the whole weight of the brush rests on the silk and soon wears it out, and in others the brush is set at an angle on the reel and acts as a wiper rather than a brush, the difficulty in this being that such a brush becomes itself clogged up, as its bristles are not exercised so as to free themselves by agitation.

The object I have in view is to so suspend and connect the brush that its weight shall at all times be removed from the silk, and yet be so moved that whatever may be the contour of the reel its bristles shall come in light contact with the silk to brush it, and jump over the ribs to prevent wear of the ticking strips.

Referring to the accompanying drawings, Figure 1 is a perspective view of my automatic flour-bolt cleaner. Fig. 2 is a side view

showing the brush-operating mechanism enlarged. Fig. 3 is a vertical section of same. Fig. 4 is a view showing the attachment of adjustable eccentric.

A is the box or casing of the reel B, in which it is mounted to revolve by means of a central shaft, C, to one end of which power is to be applied. The reel is fed in the usual manner through one end.

D represents the silk sides of the reel, and D' the ticking strips over the ribs *d* or angle-lines.

Mounted transversely in the box above the reel is a shaft, E, from which arms *e* extend, which carry the brush F. One end of the shaft E is provided with a crank, G, having a slotted end.

H is a metal piece, the lower portion of which is formed into a loop, *h*, from which a short arm, *h'*, extends downwardly through a socket-arm, *h''*, secured to the box or frame, whereby the piece H is guided in its vertical movement. A bar, I, the upper end of which is connected with the crank G, extends downwardly behind piece H, guided by being let into said piece, and having a cross-head, I', on its lower end, which extends between the sides of loop *h*, forming the upper side of the eccentric-strap, as I shall explain.

J is a bracket secured to the main frame, in which and in said frame is mounted a counter-shaft, K, on which is secured an eccentric, L, confined by the strap formed by loop *h* and cross-head I'. This shaft carries a pinion, *m*, which meshes with a large gear, M, on the main driving-shaft.

The effect of the mechanism as far as explained is as follows: The power which turns the reel also oscillates shaft E, being transmitted through gear M and pinion *m*, counter-shaft K, eccentric L and its strap, bar I, and crank G. This oscillation of the shaft E raises and lowers the brush F. To give the brush its proper movement both in extent and time is a matter of calculation. For example, if the reel be hexagonal, the brush would have to rise and fall six times in the revolution of the reel—once for each side; therefore there would have to be six revolutions of the eccentric to one of the reel, which is accomplished by making the proportion of the teeth of the gear and pinion as six is to one. If the large

gear has ninety-six teeth, the small one would have sixteen, and for every hexagonal reel this proportion would be maintained. For an octagonal reel the proportion would be as 5
 8 to one, and so on. This adjustment makes the operation of the brush certain for each side of the reel. As to the extent of the movement of the brush, this is governed by the size and character of the reel as to the number of sides, and is regulated by giving 10
 the proper throw to the eccentric. For a hexagonal reel the throw would have to be greater than for an octagonal one, or for any greater number of sides, because the greater the number 15
 of sides the less acute are the angles they form, and therefore the brush is required to have less rise and fall. In order to provide for such adjustment of the throw of the eccentric, I show a means in Fig. 4. The eccentric 20
 is slotted, and is fixed to the shaft by a set-screw, *a*, which allows, when loosened, the eccentric to move on the shaft nearer to or farther from the center, to decrease or increase its eccentricity, a block of wood, *a'*, or other 25
 material being placed in the slot on the opposite side, for the shaft to bear against when the screw is retightened. The eccentric is so formed that it gives to the shaft E just enough vibration to cause the brush to rise and fall in 30
 a course conformable to that of the reel, so that its bristles shall come in contact with the sides of the reel with sufficient pressure to brush the silk, and not enough to wear it out. If the brush were allowed to act over the ribs 35
 as well as over the sides of the reel, it would have a tendency to wear out the ticking strips D', which cannot sustain as much friction as the silk. I therefore provide means for giving the brush a sudden rise, sufficient to allow 40
 the ribs to pass under it without coming in contact with its bristles.

The bar I is not fastened directly to piece H, and it has a supplementary movement of its own. It is provided with an elongated slot, 45
i, through which passes a squared bolt, N, the end of which receives a nut, *n*. In the slot *i*, between this bolt and the bottom of the slot, is a spring, O, which is guided and held to its place by a pin, *o*, extending downwardly from 50
 the bolt, and a small pin, *o'*, extending upwardly from the bottom of the slot. Upon the head or outer end of the bolt is fitted eccentrically a disk or plate, P, operating between 55
 guide-flanges *p* on the piece H, the upper flange being grooved for the reception of the upper edge of the disk, whereby it is steadied and held in place. This disk, while serving the purpose of connecting the bar I with the piece H, is in reality a cam, by the operation of 60
 which the device is thrown into and out of gear, as I shall presently explain. The tendency of the spring O is to keep the strap tight upon the eccentric, and still allow for its yielding when necessary.

65 Upon one side of the eccentric L is a cam, Q, consisting of a flange-strip, and upon the edge of cross-head I' is a projecting lip or lug,

i', against which the cam Q impinges in the revolution of the eccentric, Fig. 3. This cam is so arranged with respect to the eccentric 70
 that its operation takes place as the ribs of the reel approach the brush. It lifts the bar I suddenly and to a sufficient distance to oscillate the shaft E enough to raise the brush to clear the rib as it passes under. When re- 75
 lieved of the cam Q, the strap returns to its normal position upon the eccentric.

The cam-disk P is provided with a lever-handle, R, by which it is turned, and I cut 80
 notches *r* in the guide-flanges *p*, with which the lever-handle engages to hold the cam in position. When the handle is turned up, the parts are in gear; but when the cam is turned with its handle down, the bar I and piece H 85
 are moved in opposite directions, thus allowing the strap to expand and relieve the eccentric, which no longer affects the brush. The parts are held separated by resting the handle-lever upon some part below, and in this connection I make this very adjustment serve 90
 the purpose of a brake to prevent the wear of the gearing.

Upon the counter-shaft is secured centrally a disk, S, upon the periphery of which the 95
 end of the lever-handle R, which is provided with a curved-faced lug, *r'*, rests. This holds the parts out of gear, and also generates enough friction to prevent what is known as "back-lash" on the gears when running free.

Two gears meshing, and having no heavy 100
 work to do, soon wear their teeth; but by means of the friction or brake I have described they are held to their work even when relieved of the brush mechanism.

Having thus described my invention, what I 105
 claim as new, and desire to secure by Letters Patent, is—

1. A flour-bolt reel having ribs, as described, in combination with a brush the bristles of which are adapted to come in contact with the 110
 periphery of the reel, means, substantially as described, for supporting the brush independent of the reel, mechanism, as described, for imparting to said brush an independent movement to keep it in contact with the periphery 115
 of the revolving reel between its ribs, and mechanism, as herein set forth, to cause its temporary rise to clear the ribs, substantially as described.

2. The flour-bolt reel B, having ribs *d*, in 120
 combination with the brush F, the bristles of which touch the reel, shaft E, and arms *e*, and mechanism, substantially as described, for oscillating said shaft, to impart to the brush a positive and independent movement conform- 125
 ing to the periphery of the revolving reel between the ribs, and to cause its temporary rise to clear the ribs, substantially as described.

3. The flour-bolt reel B and its central driving-shaft, C, in combination with the brush F; 130
 shaft E, having arms *e* and crank G, and an eccentric connection between said driving-shaft and crank, for oscillating said shaft E to impart to the brush a positive and independent

movement conforming to the periphery of the reel when revolved, substantially as herein described.

4. The flour-bolt reel B, the central driving-shaft, C, and the gear M on the shaft, in combination with the brush F, shaft E, arms *e*, and crank G, an eccentric strap or loop connected with said crank, the counter-shaft K, eccentric L in said strap, and pinion *m*, substantially as herein described.

5. The polygonal flour-bolt reel B and central shaft, C, in combination with the brush F, shaft E, arms *e*, and crank G, an adjustable eccentric for vibrating the crank, and a gear on the reel-shaft and pinion on the eccentric-shaft meshing with each other for operating the eccentric, said gear and pinion bearing in their times of revolution the proportion to each other as the number of sides of the reel to one, substantially as and for the purpose herein described.

6. The flour-bolt reel B, central shaft, C, and gear M, in combination with the brush F, shaft E, arms *e*, and crank G, slotted bar I, cross-head I', with flange or lip *i'*, piece H, having loop *h*, spring O in the slot, bolt N, connected with piece H, the counter-shaft K, having eccentric L, with cam Q, and pinion *m*, all arranged and operating substantially as and for the purpose herein described.

7. The flour-bolt reel B, central shaft, C, and gear M, in combination with the brush F, shaft E, arms *e*, and crank G, bar I, cross-head I',

piece H, having loop *h*, with guide-pin *h'* and guide-flanges *p*, bolt N, cam-disk P on said bolt, with lever-handle R, counter-shaft K, eccentric L, and pinion *m*, all arranged and operating substantially as and for the purpose herein described.

8. The flour-bolt reel B, central shaft, C, and gear M, in combination with the brush F, shaft E, arms *e*, and crank G, bar I, cross-head I', piece H, having loop *h*, with guide-pin *h'* and guide-flanges *p*, bolt N, cam-disk P on said bolt, having lever-handle R, with curved-faced lug *r'*, counter-shaft K, having eccentric L, and the disk S, upon which the curved-faced lug *r'* impinges when handle R is turned down, and pinion *m*, all arranged and operating substantially as herein described.

9. In a flour-bolt, and in combination with the brush, rock-shaft E, and pitman-connection H I, the counter-shaft K, as herein described, the eccentric L, having a slot through which said shaft loosely passes, the set-screw *a*, and opposing block *a'*, whereby the throw of the eccentric may be varied by moving it on the shaft, substantially as and for the purpose herein described.

In witness whereof I have hereunto set my hand.

ALBERT F. MASE.

Witnesses:

WM. F. BOOTH,
H. C. LEE.