



(51) International Patent Classification:

H04W 72/10 (2009.01) H04W 28/02 (2009.01)
H04W 72/04 (2009.01)

(21) International Application Number:

PCT/KR2019/007349

(22) International Filing Date:

18 June 2019 (18.06.2019)

(25) Filing Language:

English

(26) Publication Language:

English

(30) Priority Data:

10-2018-0069573 18 June 2018 (18.06.2018) KR

(71) Applicant: **LG ELECTRONICS INC.** [KR/KR]; 128, Yeoui-daero, Yeongdeungpo-Gu, Seoul 07336 (KR).

(72) Inventors: **KIM, Jayeong**; IP Center, LG Electronics Inc., 19, Yangjae-daero 11-gil, Seocho-Gu, Seoul 06772 (KR).
LEE, Sunyoung; IP Center, LG Electronics Inc., 19, Yangjae-daero 11-gil, Seocho-Gu, Seoul 06772 (KR).

(74) Agent: **KIM, Yong In** et al.; KBK & Associates, 7th Floor, 82, Olympic-ro, Songpa-Gu, Seoul 05556 (KR).

(81) Designated States (unless otherwise indicated, for every kind of national protection available): AE, AG, AL, AM, AO, AT, AU, AZ, BA, BB, BG, BH, BN, BR, BW, BY, BZ,

CA, CH, CL, CN, CO, CR, CU, CZ, DE, DJ, DK, DM, DO, DZ, EC, EE, EG, ES, FI, GB, GD, GE, GH, GM, GT, HN, HR, HU, ID, IL, IN, IR, IS, JO, JP, KE, KG, KH, KN, KP, KR, KW, KZ, LA, LC, LK, LR, LS, LU, LY, MA, MD, ME, MG, MK, MN, MW, MX, MY, MZ, NA, NG, NI, NO, NZ, OM, PA, PE, PG, PH, PL, PT, QA, RO, RS, RU, RW, SA, SC, SD, SE, SG, SK, SL, SM, ST, SV, SY, TH, TJ, TM, TN, TR, TT, TZ, UA, UG, US, UZ, VC, VN, ZA, ZM, ZW.

(84) Designated States (unless otherwise indicated, for every kind of regional protection available):

ARIPO (BW, GH, GM, KE, LR, LS, MW, MZ, NA, RW, SD, SL, ST, SZ, TZ, UG, ZM, ZW), Eurasian (AM, AZ, BY, KG, KZ, RU, TJ, TM), European (AL, AT, BE, BG, CH, CY, CZ, DE, DK, EE, ES, FI, FR, GB, GR, HR, HU, IE, IS, IT, LT, LU, LV, MC, MK, MT, NL, NO, PL, PT, RO, RS, SE, SI, SK, SM, TR), OAPI (BF, BJ, CF, CG, CI, CM, GA, GN, GQ, GW, KM, ML, MR, NE, SN, TD, TG).

Published:

— with international search report (Art. 21(3))

(54) Title: METHOD FOR ALLOCATING RESOURCES TO LOGICAL CHANNELS BY TRANSMISSION END IN WIRELESS COMMUNICATION SYSTEM AND AN APPARATUS THEREFOR

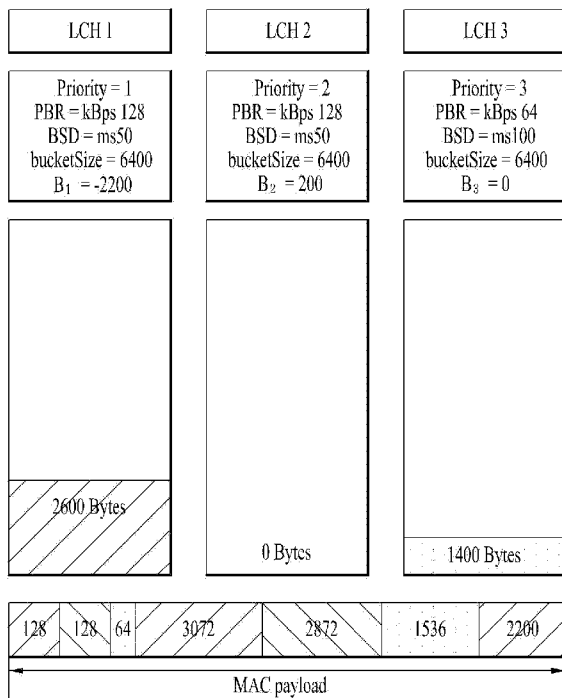

(57) Abstract: A method for allocating resources by a transmission end in a wireless communication system is disclosed. The method includes steps of receiving an uplink grant for first and second logical channels; generating a data unit including data from the first and second logical channels based on the uplink grant; and transmitting the data unit to a network, wherein generating the data unit comprises: allocating the resources indicated by the uplink grant to first and second logical channels having positive token values by amount of corresponding prioritized bit rates (PBRs) with decrementing corresponding token values of each logical channel by amount of allocated resources; if a token value of the first logical channel is greater than 0, allocating remaining resources to the first logical channel until the token value of the first logical channel becomes zero; and if a token value of the second logical channel is greater than 0, allocating remaining resources to the second logical channel until the token value of the second logical channel becomes zero.



Description

Title of Invention: METHOD FOR ALLOCATING RESOURCES TO LOGICAL CHANNELS BY TRANSMISSION END IN WIRELESS COMMUNICATION SYSTEM AND AN APPARATUS THEREFOR

Technical Field

- [1] The present invention relates to a wireless communication system and, more particularly, to a method for allocating resources to logical channels by a transmission end in a wireless communication system and an apparatus therefor.

Background Art

- [2] Introduction of new radio communication technologies has led to increases in the number of user equipments (UEs) to which a base station (BS) provides services in a prescribed resource region, and has also led to increases in the amount of data and control information that the BS transmits to the UEs. Due to typically limited resources available to the BS for communication with the UE(s), new techniques are needed by which the BS utilizes the limited radio resources to efficiently receive/transmit uplink/downlink data and/or uplink/downlink control information. In particular, overcoming delay or latency has become an important challenge in applications whose performance critically depends on delay/latency.

Disclosure of Invention

Technical Problem

- [3] Based on the above discussion, the present invention proposes a method for allocating resources to logical channels by a transmission end in a wireless communication system and an apparatus therefor.

Solution to Problem

- [4] In accordance with an embodiment of the present invention, a method for allocating resources by a transmission end in a wireless communication system includes receiving an uplink grant for first and second logical channels; generating a data unit including data from the first and second logical channels based on the uplink grant; and transmitting the data unit to a network, wherein generating the data unit comprises: allocating the resources indicated by the uplink grant to first and second logical channels having positive token values by amount of corresponding prioritized bit rates (PBRs) with decrementing corresponding token values of each logical channel by amount of allocated resources; if a token value of the first logical channel is greater than 0, allocating remaining resources to the first logical channel until the token value of the

first logical channel becomes zero; and if a token value of the second logical channel is greater than 0, allocating remaining resources to the second logical channel until the token value of the second logical channel becomes zero.

- [5] Further, in accordance with another embodiment of the present invention, An apparatus for wireless communications comprising a radio frequency (RF) module; a memory; and at least one processor coupled to the memory and the RF module, wherein the at least one processor is configured to receive an uplink grant for first and second logical channels; generate a data unit including data from the first and second logical channels based on the uplink grant; and transmit the data unit to a network. Especially, when the at least one processor generates the data unit, the at least one processor is configured to allocate resources indicated by the uplink grant to first and second logical channels having positive token values by amount of corresponding prioritized bit rates (PBRs) with decrementing corresponding token values of each logical channel by amount of allocated resources; if a token value of the first logical channel is greater than 0, allocate remaining resources to the first logical channel until the token value of the first logical channel becomes zero; and if a token value of the second logical channel is greater than 0, allocate remaining resources to the second logical channel until the token value of the second logical channel becomes zero.
- [6] Preferably, the at least one processor is further configured to implement at least one advanced diver assistance system (ADAS) function based on signals that control the UE.
- [7] Preferably, if remaining resources are exist and remaining data from the first logical channel exists after the token value of the second logical channel becomes zero, remaining resources are allocated to the first logical channel regardless of the token value of the first logical channel until the resources indicated by the uplink grant are exhausted.
- [8] Preferably, a priority of the first logical channel is higher than a priority of the second logical channel.
- [9] Preferably, if the token value of the first logical channel is greater than 0 and if amount of remaining data from the first logical channel is less than the token value of the first logical channel, the at least one processor is further configured to allocate the remaining resources to the first logical channel by the amount of remaining data from the first logical channel. More preferably, if the token value of the second logical channel is greater than 0 and if amount of remaining data from the second logical channel is less than the token value of the second logical channel, the at least one processor is further configured to allocate the remaining resources to the second logical channel by the amount of remaining data from the second logical channel.
- [10] It is to be understood that both the foregoing general description and the following

detailed description of the present invention are exemplary and explanatory and are intended to provide further explanation of the invention as claimed.

Advantageous Effects of Invention

[11] According to embodiments of the present invention, Logical channel prioritization (LCP) procedure can be performed efficiently by allocating resources to the logical channels.

[12] It will be appreciated by persons skilled in the art that that the effects that can be achieved through the present invention are not limited to what has been particularly described hereinabove and other advantages of the present invention will be more clearly understood from the following detailed description.

Brief Description of Drawings

[13] The accompanying drawings, which are included to provide a further understanding of the invention and are incorporated in and constitute a part of this application, illustrate embodiment(s) of the invention and together with the description serve to explain the principle of the invention.

[14] In the drawings:

[15] FIG. 1 is a diagram illustrating an example of a network structure of an evolved universal mobile telecommunication system (E-UMTS) as an exemplary radio communication system;

[16] FIG. 2 is a block diagram illustrating an example of an evolved universal terrestrial radio access network (E-UTRAN);

[17] FIG. 3 is a block diagram depicting an example of an architecture of a typical E-UTRAN and a typical EPC;

[18] FIG. 4 is a diagram showing an example of a control plane and a user plane of a radio interface protocol between a UE and an E-UTRAN based on a 3GPP radio access network standard;

[19] FIG. 5 is a diagram showing an example of a physical channel structure used in an E-UMTS system;

[20] FIG. 6 illustrates an example of protocol stacks of a next generation wireless communication system;

[21] FIG. 7 illustrates an example of a data flow example at a transmitting device in the NR system;

[22] FIG. 8 illustrates an example of a slot structure available in a new radio access technology (NR);

[23] FIG. 9 shows an example of configuration of logical channels according to the embodiment of the present invention.

[24] FIG. 10 shows an example of buffer status and Bj of logical channels according to

the embodiment of the present invention.

[25] FIG. 11 shows an example of a first round of resource allocation according to the embodiment of the present invention.

[26] FIG. 12 and FIG. 13 show examples of a second round of resource allocation according to the embodiment of the present invention.

[27] FIG. 14 shows an example of a third round of resource allocation according to the embodiment of the present invention.

[28] FIG. 15 is a block diagram illustrating an example of elements of a transmitting device 100 and a receiving device 200 according to some implementations of the present disclosure.

Best Mode for Carrying out the Invention

[29] Hereinafter, structures, operations, and other features of the present invention will be readily understood from the embodiments of the present invention, examples of which are illustrated in the accompanying drawings. Embodiments described later are examples in which technical features of the present invention are applied to a 3GPP system.

[30] FIG. 1 is a diagram illustrating an example of a network structure of an E-UMTS as an exemplary radio communication system. An Evolved Universal Mobile Telecommunications System (E-UMTS) is an advanced version of a Universal Mobile Telecommunications System (UMTS) and basic standardization thereof is currently underway in the 3GPP. E-UMTS may be generally referred to as a Long Term Evolution (LTE) system. For details of the technical specifications of the UMTS and E-UMTS, reference can be made to Release 7 and Release 8 of "3rd Generation Partnership Project; Technical Specification Group Radio Access Network".

[31] Referring to FIG. 1, the E-UMTS includes a User Equipment (UE), eNode Bs (eNBs), and an Access Gateway (AG) which is located at an end of the network (E-UTRAN) and connected to an external network. The eNBs may simultaneously transmit multiple data streams for a broadcast service, a multicast service, and/or a unicast service.

[32] One or more cells may exist per eNB. The cell is set to operate in one of bandwidths such as 1.25, 2.5, 5, 10, 15, and 20 MHz and provides a downlink (DL) or uplink (UL) transmission service to a plurality of UEs in the bandwidth. Different cells may be set to provide different bandwidths. The eNB controls data transmission or reception to and from a plurality of UEs. The eNB transmits DL scheduling information of DL data to a corresponding UE so as to inform the UE of a time/frequency domain in which the DL data is supposed to be transmitted, coding, a data size, and hybrid automatic repeat and request (HARQ)-related information. In addition, the eNB transmits UL

scheduling information of UL data to a corresponding UE so as to inform the UE of a time/frequency domain which may be used by the UE, coding, a data size, and HARQ-related information. An interface for transmitting user traffic or control traffic may be used between eNBs. A core network (CN) may include the AG and a network node or the like for user registration of UEs. The AG manages the mobility of a UE on a tracking area (TA) basis. One TA includes a plurality of cells.

[33] Although wireless communication technology has been developed to LTE based on wideband code division multiple access (WCDMA), the demands and expectations of users and service providers are on the rise. In addition, considering other radio access technologies under development, new technological evolution is required to secure high competitiveness in the future. Decrease in cost per bit, increase in service availability, flexible use of frequency bands, a simplified structure, an open interface, appropriate power consumption of UEs, and the like are required.

[34] As more and more communication devices demand larger communication capacity, there is a need for improved mobile broadband communication compared to existing RAT. Also, massive machine type communication (MTC), which provides various services by connecting many devices and objects, is one of the major issues to be considered in the next generation communication. In addition, a communication system design considering a service/UE sensitive to reliability and latency is being discussed. The introduction of next-generation RAT, which takes into account such advanced mobile broadband communication, massive MTC (mMTC), and ultra-reliable and low latency communication (URLLC), is being discussed.

[35] Reference will now be made in detail to the exemplary implementations of the present disclosure, examples of which are illustrated in the accompanying drawings. The detailed description, which will be given below with reference to the accompanying drawings, is intended to explain exemplary implementations of the present disclosure, rather than to show the only implementations that can be implemented according to the disclosure. The following detailed description includes specific details in order to provide a thorough understanding of the present disclosure. However, it will be apparent to those skilled in the art that the present disclosure may be practiced without such specific details.

[36] The following techniques, apparatuses, and systems may be applied to a variety of wireless multiple access systems. Examples of the multiple access systems include a code division multiple access (CDMA) system, a frequency division multiple access (FDMA) system, a time division multiple access (TDMA) system, an orthogonal frequency division multiple access (OFDMA) system, a single carrier frequency division multiple access (SC-FDMA) system, and a multicarrier frequency division multiple access (MC-FDMA) system. CDMA may be embodied through radio

technology such as universal terrestrial radio access (UTRA) or CDMA2000. TDMA may be embodied through radio technology such as global system for mobile communications (GSM), general packet radio service (GPRS), or enhanced data rates for GSM evolution (EDGE). OFDMA may be embodied through radio technology such as institute of electrical and electronics engineers (IEEE) 802.11 (Wi-Fi), IEEE 802.16 (WiMAX), IEEE 802.20, or evolved UTRA (E-UTRA). UTRA is a part of a universal mobile telecommunications system (UMTS). 3rd generation partnership project (3GPP) long term evolution (LTE) is a part of evolved UMTS (E-UMTS) using E-UTRA. 3GPP LTE employs OFDMA in DL and SC-FDMA in UL. LTE-advanced (LTE-A) is an evolved version of 3GPP LTE. For convenience of description, implementations of the present disclosure are described in regards to a 3GPP based wireless communication system. However, the technical features of the present disclosure are not limited thereto. For example, although the following detailed description is given based on a mobile communication system corresponding to a 3GPP based system, aspects of the present disclosure that are not limited to 3GPP based system are applicable to other mobile communication systems.

- [37] For example, the present disclosure is applicable to contention based communication such as Wi-Fi as well as non-contention based communication as in the 3GPP based system in which a BS allocates a DL/UL time/frequency resource to a UE and the UE receives a DL signal and transmits a UL signal according to resource allocation of the BS. In a non-contention based communication scheme, an access point (AP) or a control node for controlling the AP allocates a resource for communication between the UE and the AP, whereas, in a contention based communication scheme, a communication resource is occupied through contention between UEs which desire to access the AP. The contention based communication scheme will now be described in brief. One type of the contention based communication scheme is carrier sense multiple access (CSMA). CSMA refers to a probabilistic media access control (MAC) protocol for confirming, before a node or a communication device transmits traffic on a shared transmission medium (also called a shared channel) such as a frequency band, that there is no other traffic on the same shared transmission medium. In CSMA, a transmitting device determines whether another transmission is being performed before attempting to transmit traffic to a receiving device. In other words, the transmitting device attempts to detect presence of a carrier from another transmitting device before attempting to perform transmission. Upon sensing the carrier, the transmitting device waits for another transmission device which is performing transmission to finish transmission, before performing transmission thereof. Consequently, CSMA can be a communication scheme based on the principle of “sense before transmit” or “listen before talk”. A scheme for avoiding collision between transmitting devices in the

contention based communication system using CSMA includes carrier sense multiple access with collision detection (CSMA/CD) and/or carrier sense multiple access with collision avoidance (CSMA/CA). CSMA/CD is a collision detection scheme in a wired local area network (LAN) environment. In CSMA/CD, a personal computer (PC) or a server which desires to perform communication in an Ethernet environment first confirms whether communication occurs on a network and, if another device carries data on the network, the PC or the server waits and then transmits data. That is, when two or more users (e.g. PCs, UEs, etc.) simultaneously transmit data, collision occurs between simultaneous transmission and CSMA/CD is a scheme for flexibly transmitting data by monitoring collision. A transmitting device using CSMA/CD adjusts data transmission thereof by sensing data transmission performed by another device using a specific rule. CSMA/CA is a MAC protocol specified in IEEE 802.11 standards. A wireless LAN (WLAN) system conforming to IEEE 802.11 standards does not use CSMA/CD which has been used in IEEE 802.3 standards and uses CA, i.e. a collision avoidance scheme. Transmission devices always sense carrier of a network and, if the network is empty, the transmission devices wait for determined time according to locations thereof registered in a list and then transmit data. Various methods are used to determine priority of the transmission devices in the list and to re-configure priority. In a system according to some versions of IEEE 802.11 standards, collision may occur and, in this case, a collision sensing procedure is performed. A transmission device using CSMA/CA avoids collision between data transmission thereof and data transmission of another transmission device using a specific rule.

[38] In the present disclosure, a user equipment (UE) may be a fixed or mobile device. Examples of the UE include various devices that transmit and receive user data and/or various kinds of control information to and from a base station (BS). The UE may be referred to as a terminal equipment (TE), a mobile station (MS), a mobile terminal (MT), a user terminal (UT), a subscriber station (SS), a wireless device, a personal digital assistant (PDA), a wireless modem, a handheld device, etc. In addition, in the present disclosure, a BS generally refers to a fixed station that performs communication with a UE and/or another BS, and exchanges various kinds of data and control information with the UE and another BS. The BS may be referred to as an advanced base station (ABS), a node-B (NB), an evolved node-B (eNB), a base transceiver system (BTS), an access point (AP), a processing server (PS), etc. Especially, a BS of the UMTS is referred to as a NB, a BS of the EPC/LTE is referred to as an eNB, and a BS of the new radio (NR) system is referred to as a gNB.

[39] In the present disclosure, a node refers to a fixed point capable of transmitting/receiving a radio signal through communication with a UE. Various types of BSs may be used as nodes irrespective of the terms thereof. For example, a BS, a node B (NB),

an e-node B (eNB), a pico-cell eNB (PeNB), a home eNB (HeNB), a relay, a repeater, etc. may be a node. In addition, the node may not be a BS. For example, the node may be a radio remote head (RRH) or a radio remote unit (RRU). The RRH or RRU generally has a lower power level than a power level of a BS. Since the RRH or RRU (hereinafter, RRH/RRU) is generally connected to the BS through a dedicated line such as an optical cable, cooperative communication between RRH/RRU and the BS can be smoothly performed in comparison with cooperative communication between BSs connected by a radio line. At least one antenna is installed per node. The antenna may include a physical antenna or an antenna port or a virtual antenna.

[40] In the present disclosure, a cell refers to a prescribed geographical area to which one or more nodes provide a communication service. Accordingly, in the present disclosure, communicating with a specific cell may include communicating with a BS or a node which provides a communication service to the specific cell. In addition, a DL/UL signal of a specific cell refers to a DL/UL signal from/to a BS or a node which provides a communication service to the specific cell. A node providing UL/DL communication services to a UE is called a serving node and a cell to which UL/DL communication services are provided by the serving node is especially called a serving cell.

[41] In some scenarios, a 3GPP based system implements a cell to manage radio resources and a cell associated with the radio resources is distinguished from a cell of a geographic region.

[42] A "cell" of a geographic region may be understood as coverage within which a node can provide service using a carrier and a "cell" of a radio resource is associated with bandwidth (BW) which is a frequency range configured by the carrier. Since DL coverage, which is a range within which the node is capable of transmitting a valid signal, and UL coverage, which is a range within which the node is capable of receiving the valid signal from the UE, depends upon a carrier carrying the signal, the coverage of the node may be associated with coverage of the "cell" of a radio resource used by the node. Accordingly, the term "cell" may be used to indicate service coverage of the node sometimes, a radio resource at other times, or a range that a signal using a radio resource can reach with valid strength at other times.

[43] In some scenarios, the recent 3GPP based wireless communication standard implements a cell to manage radio resources. The "cell" associated with the radio resources utilizes a combination of downlink resources and uplink resources, for example, a combination of DL component carrier (CC) and UL CC. The cell may be configured by downlink resources only, or may be configured by downlink resources and uplink resources. If carrier aggregation is supported, linkage between a carrier frequency of the downlink resources (or DL CC) and a carrier frequency of the uplink resources (or UL CC) may be indicated by system information. For example, com-

bination of the DL resources and the UL resources may be indicated by linkage of system information block type 2 (SIB2). In this case, the carrier frequency may be a center frequency of each cell or CC. A cell operating on a primary frequency may be referred to as a primary cell (Pcell) or PCC, and a cell operating on a secondary frequency may be referred to as a secondary cell (Scell) or SCC. The carrier corresponding to the Pcell on downlink will be referred to as a downlink primary CC (DL PCC), and the carrier corresponding to the Pcell on uplink will be referred to as an uplink primary CC (UL PCC). A Scell refers to a cell that may be configured after completion of radio resource control (RRC) connection establishment and used to provide additional radio resources. The Scell may form a set of serving cells for the UE together with the Pcell in accordance with capabilities of the UE. The carrier corresponding to the Scell on the downlink will be referred to as downlink secondary CC (DL SCC), and the carrier corresponding to the Scell on the uplink will be referred to as uplink secondary CC (UL SCC). Although the UE is in RRC-CONNECTED state, if it is not configured by carrier aggregation or does not support carrier aggregation, a single serving cell configured by the Pcell only exists.

[44] In the present disclosure, "PDCCH" refers to a PDCCH, an EPDCCH (in subframes when configured), a MTC PDCCH (MPDCCH), for an RN with R-PDCCH configured and not suspended, to the R-PDCCH or, for NB-IoT to the narrowband PDCCH (NPDCCH).

[45] In the present disclosure, monitoring a channel refers to attempting to decode the channel. For example, monitoring a PDCCH refers to attempting to decode PDCCH(s) (or PDCCH candidates).

[46] For terms and technologies which are not specifically described among the terms of and technologies employed in this specification, 3GPP LTE/LTE-A standard documents, for example, 3GPP TS 36.211, 3GPP TS 36.212, 3GPP TS 36.213, 3GPP TS 36.300, 3GPP TS 36.321, 3GPP TS 36.322, 3GPP TS 36.323 and 3GPP TS 36.331, and 3GPP NR standard documents, for example, 3GPP TS 38.211, 3GPP TS 38.213, 3GPP TS 38.214, 3GPP TS 38.300, 3GPP TS 38.321, 3GPP TS 38.322, 3GPP TS 38.323 and 3GPP TS 38.331 may be referenced.

[47] FIG. 2 is a block diagram illustrating an example of an evolved universal terrestrial radio access network (E-UTRAN). The E-UMTS may be also referred to as an LTE system. The communication network is widely deployed to provide a variety of communication services such as voice (VoIP) through IMS and packet data.

[48] As illustrated in FIG. 2, the E-UMTS network includes an evolved UMTS terrestrial radio access network (E-UTRAN), an Evolved Packet Core (EPC) and one or more user equipment. The E-UTRAN may include one or more evolved NodeB (eNodeB) 20, and a plurality of user equipments (UE) 10 may be located in one cell. One or more

E-UTRAN mobility management entity (MME)/system architecture evolution (SAE) gateways 30 may be positioned at the end of the network and connected to an external network.

- [49] As used herein, “downlink” refers to communication from BS 20 to UE 10, and “uplink” refers to communication from the UE to a BS.
- [50] FIG. 3 is a block diagram depicting an example of an architecture of a typical E-UTRAN and a typical EPC.
- [51] As illustrated in FIG. 3, an eNB 20 provides end points of a user plane and a control plane to the UE 10. MME/SAE gateway 30 provides an end point of a session and mobility management function for UE 10. The eNB and MME/SAE gateway may be connected via an S1 interface.
- [52] The eNB 20 is generally a fixed station that communicates with a UE 10, and may also be referred to as a base station (BS) or an access point. One eNB 20 may be deployed per cell. An interface for transmitting user traffic or control traffic may be used between eNBs 20.
- [53] The MME provides various functions including NAS signaling to eNBs 20, NAS signaling security, access stratum (AS) Security control, Inter CN node signaling for mobility between 3GPP access networks, Idle mode UE Reachability (including control and execution of paging retransmission), Tracking Area list management (for UE in idle and active mode), PDN GW and Serving GW selection, MME selection for handovers with MME change, SGSN selection for handovers to 2G or 3G 3GPP access networks, roaming, authentication, bearer management functions including dedicated bearer establishment, support for PWS (which includes ETWS and CMAS) message transmission. The SAE gateway host provides assorted functions including Per-user based packet filtering (by e.g. deep packet inspection), Lawful Interception, UE IP address allocation, Transport level packet marking in the downlink, UL and DL service level charging, gating and rate enforcement, DL rate enforcement based on APN-AMBR. For clarity MME/SAE gateway 30 will be referred to herein simply as a “gateway,” but it is understood that this entity includes both an MME and an SAE gateway.
- [54] A plurality of nodes may be connected between eNB 20 and gateway 30 via the S1 interface. The eNBs 20 may be connected to each other via an X2 interface and neighboring eNBs may have a meshed network structure that has the X2 interface.
- [55] As illustrated, eNB 20 may perform functions of selection for gateway 30, routing toward the gateway during a Radio Resource Control (RRC) activation, scheduling and transmitting of paging messages, scheduling and transmitting of Broadcast Channel (BCCH) information, dynamic allocation of resources to UEs 10 in both uplink and downlink, configuration and provisioning of eNB measurements, radio bearer control,

radio admission control (RAC), and connection mobility control in LTE_ACTIVE state. In the EPC, and as noted above, gateway 30 may perform functions of paging origination, LTE-IDLE state management, ciphering of the user plane, System Architecture Evolution (SAE) bearer control, and ciphering and integrity protection of Non-Access Stratum (NAS) signaling.

- [56] The EPC includes a mobility management entity (MME), a serving-gateway (S-GW), and a packet data network-gateway (PDN-GW). The MME has information about connections and capabilities of UEs, mainly for use in managing the mobility of the UEs. The S-GW is a gateway having the E-UTRAN as an end point, and the PDN-GW is a gateway having a packet data network (PDN) as an end point.
- [57] FIG. 4 is a diagram showing an example of a control plane and a user plane of a radio interface protocol between a UE and an E-UTRAN based on a 3GPP radio access network standard. The control plane refers to a path used for transmitting control messages used for managing a call between the UE and the E-UTRAN. The user plane refers to a path used for transmitting data generated in an application layer, e.g., voice data or Internet packet data.
- [58] Layer 1 (i.e. L1) of the 3GPP LTE/LTE-A system is corresponding to a physical layer. A physical (PHY) layer of a first layer (Layer 1 or L1) provides an information transfer service to a higher layer using a physical channel. The PHY layer is connected to a medium access control (MAC) layer located on the higher layer via a transport channel. Data is transported between the MAC layer and the PHY layer via the transport channel. Data is transported between a physical layer of a transmitting side and a physical layer of a receiving side via physical channels. The physical channels use time and frequency as radio resources. In detail, the physical channel is modulated using an orthogonal frequency division multiple access (OFDMA) scheme in downlink and is modulated using a single carrier frequency division multiple access (SC-FDMA) scheme in uplink.
- [59] Layer 2 (i.e. L2) of the 3GPP LTE/LTE-A system is split into the following sublayers: Medium Access Control (MAC), Radio Link Control (RLC) and Packet Data Convergence Protocol (PDCP). The MAC layer of a second layer (Layer 2 or L2) provides a service to a radio link control (RLC) layer of a higher layer via a logical channel. The RLC layer of the second layer supports reliable data transmission. A function of the RLC layer may be implemented by a functional block of the MAC layer. A packet data convergence protocol (PDCP) layer of the second layer performs a header compression function to reduce unnecessary control information for efficient transmission of an Internet protocol (IP) packet such as an IP version 4 (IPv4) packet or an IP version 6 (IPv6) packet in a radio interface having a relatively small bandwidth.

- [60] The main services and functions of the MAC sublayer include: mapping between logical channels and transport channels; multiplexing/demultiplexing of MAC SDUs belonging to one or different logical channels into/from transport blocks (TB) delivered to/from the physical layer on transport channels; scheduling information reporting; error correction through HARQ; priority handling between logical channels of one UE; priority handling between UEs by dynamic scheduling; MBMS service identification; transport format selection; and padding.
- [61] The main services and functions of the RLC sublayer include: transfer of upper layer protocol data units (PDUs); error correction through ARQ (only for acknowledged mode (AM) data transfer); concatenation, segmentation and reassembly of RLC service data units (SDUs) (only for unacknowledged mode (UM) and acknowledged mode (AM) data transfer); re-segmentation of RLC data PDUs (only for AM data transfer); reordering of RLC data PDUs (only for UM and AM data transfer); duplicate detection (only for UM and AM data transfer); protocol error detection (only for AM data transfer); RLC SDU discard (only for UM and AM data transfer); and RLC re-establishment, except for a NB-IoT UE that only uses Control Plane CIoT EPS optimizations.
- [62] The main services and functions of the PDCP sublayer for the user plane include: header compression and decompression (ROHC only); transfer of user data; in-sequence delivery of upper layer PDUs at PDCP re-establishment procedure for RLC AM; for split bearers in DC and LWA bearers (only support for RLC AM), PDCP PDU routing for transmission and PDCP PDU reordering for reception; duplicate detection of lower layer SDUs at PDCP re-establishment procedure for RLC AM; re-transmission of PDCP SDUs at handover and, for split bearers in DC and LWA bearers, of PDCP PDUs at PDCP data-recovery procedure, for RLC AM; ciphering and deciphering; timer-based SDU discard in uplink. The main services and functions of the PDCP for the control plane include: ciphering and integrity protection; and transfer of control plane data. For split and LWA bearers, PDCP supports routing and reordering. For DRBs mapped on RLC AM and for LWA bearers, the PDCP entity uses the reordering function when the PDCP entity is associated with two AM RLC entities, when the PDCP entity is configured for a LWA bearer; or when the PDCP entity is associated with one AM RLC entity after it was, according to the most recent reconfiguration, associated with two AM RLC entities or configured for a LWA bearer without performing PDCP re-establishment.
- [63] Layer 3 (i.e. L3) of the LTE/LTE-A system includes the following sublayers: Radio Resource Control (RRC) and Non Access Stratum (NAS). A radio resource control (RRC) layer located at the bottom of a third layer is defined only in the control plane. The RRC layer controls logical channels, transport channels, and physical channels in

relation to configuration, re-configuration, and release of radio bearers (RBs). An RB refers to a service that the second layer provides for data transmission between the UE and the E-UTRAN. To this end, the RRC layer of the UE and the RRC layer of the E-UTRAN exchange RRC messages with each other. The non-access stratum (NAS) layer positioned over the RRC layer performs functions such as session management and mobility management.

- [64] Radio bearers are roughly classified into (user) data radio bearers (DRBs) and signaling radio bearers (SRBs). SRBs are defined as radio bearers (RBs) that are used only for the transmission of RRC and NAS messages.
- [65] In LTE, one cell of the eNB is set to operate in one of bandwidths such as 1.25, 2.5, 5, 10, 15, and 20 MHz and provides a downlink or uplink transmission service to a plurality of UEs in the bandwidth. Different cells may be set to provide different bandwidths.
- [66] Downlink transport channels for transmission of data from the E-UTRAN to the UE include a broadcast channel (BCH) for transmission of system information, a paging channel (PCH) for transmission of paging messages, and a downlink shared channel (SCH) for transmission of user traffic or control messages. Traffic or control messages of a downlink multicast or broadcast service may be transmitted through the downlink SCH and may also be transmitted through a separate downlink multicast channel (MCH).
- [67] Uplink transport channels for transmission of data from the UE to the E-UTRAN include a random access channel (RACH) for transmission of initial control messages and an uplink SCH for transmission of user traffic or control messages. Logical channels that are defined above the transport channels and mapped to the transport channels include a broadcast control channel (BCCH), a paging control channel (PCCH), a common control channel (CCCH), a multicast control channel (MCCH), and a multicast traffic channel (MTCH).
- [68] FIG. 5 is a diagram showing an example of a physical channel structure used in an E-UMTS system. A physical channel includes several subframes on a time axis and several subcarriers on a frequency axis. Here, one subframe includes a plurality of symbols on the time axis. One subframe includes a plurality of resource blocks and one resource block includes a plurality of symbols and a plurality of subcarriers. In addition, each subframe may use certain subcarriers of certain symbols (e.g., a first symbol) of a subframe for a physical downlink control channel (PDCCH), that is, an L1/L2 control channel. The PDCCH carries scheduling assignments and other control information. In FIG. 5, an L1/L2 control information transmission area (PDCCH) and a data area (PDSCH) are shown. In one implementation, a radio frame of 10ms is used and one radio frame includes 10 subframes. In addition, in LTE, one subframe includes

two consecutive slots. The length of one slot may be 0.5ms. In addition, one subframe includes a plurality of OFDM symbols and a portion (e.g., a first symbol) of the plurality of OFDM symbols may be used for transmitting the L1/L2 control information.

[69] A time interval in which one subframe is transmitted is defined as a transmission time interval (TTI). Time resources may be distinguished by a radio frame number (or radio frame index), a subframe number (or subframe index), a slot number (or slot index), and the like. TTI refers to an interval during which data may be scheduled. For example, in the 3GPP LTE/LTE-A system, an opportunity of transmission of an UL grant or a DL grant is present every 1 ms, and the UL/DL grant opportunity does not exist several times in less than 1 ms. Therefore, the TTI in the legacy 3GPP LTE/LTE-A system is 1ms.

[70] A base station and a UE mostly transmit/receive data via a PDSCH, which is a physical channel, using a downlink shared channel (DL-SCH) which is a transmission channel, except a certain control signal or certain service data. Information indicating to which UE (one or a plurality of UEs) PDSCH data is transmitted and how the UE receive and decode PDSCH data is transmitted in a state of being included in the PDCCH.

[71] For example, in one implementation, a certain PDCCH is CRC-masked with a radio network temporary identity (RNTI) "A" and information about data is transmitted using a radio resource "B" (e.g., a frequency location) and transmission format information "C" (e.g., a transmission block size, modulation, coding information or the like) via a certain subframe. Then, one or more UEs located in a cell monitor the PDCCH using its RNTI information. And, a specific UE with RNTI "A" reads the PDCCH and then receives the PDSCH indicated by B and C in the PDCCH information. In the present disclosure, a PDCCH addressed to an RNTI refers to the PDCCH being cyclic redundancy check masked (CRC-masked) with the RNTI. A UE may attempt to decode a PDCCH using the certain RNTI if the UE is monitoring a PDCCH addressed to the certain RNTI.

[72] A fully mobile and connected society is expected in the near future, which will be characterized by a tremendous amount of growth in connectivity, traffic volume and a much broader range of usage scenarios. Some typical trends include explosive growth of data traffic, great increase of connected devices and continuous emergence of new services. Besides the market requirements, the mobile communication society itself also requires a sustainable development of the eco-system, which produces the needs to further improve system efficiencies, such as spectrum efficiency, energy efficiency, operational efficiency, and cost efficiency. To meet the above ever-increasing requirements from market and mobile communication society, next generation access

technologies are expected to emerge in the near future.

- [73] Building upon its success of IMT-2000 (3G) and IMT-Advanced (4G), 3GPP has been devoting its effort to IMT-2020 (5G) development since September 2015. 5G New Radio (NR) is expected to expand and support diverse use case scenarios and applications that will continue beyond the current IMT-Advanced standard, for instance, enhanced Mobile Broadband (eMBB), Ultra Reliable Low Latency Communication (URLLC) and massive Machine Type Communication (mMTC). eMBB is targeting high data rate mobile broadband services, such as seamless data access both indoors and outdoors, and AR/VR applications; URLLC is defined for applications that have stringent latency and reliability requirements, such as vehicular communications that can enable autonomous driving and control network in industrial plants; mMTC is the basis for connectivity in IoT, which allows for infrastructure management, environmental monitoring, and healthcare applications.
- [74] FIG. 6 illustrates an example of protocol stacks of a next generation wireless communication system. In particular, FIG. 6(a) illustrates an example of a radio interface user plane protocol stack between a UE and a gNB and FIG. 6(b) illustrates an example of a radio interface control plane protocol stack between a UE and a gNB.
- [75] The control plane refers to a path through which control messages used to manage call by a UE and a network are transported. The user plane refers to a path through which data generated in an application layer, for example, voice data or Internet packet data are transported.
- [76] Referring to FIG. 6(a), the user plane protocol stack may be divided into a first layer (Layer 1) (i.e., a physical layer (PHY) layer) and a second layer (Layer 2).
- [77] Referring to FIG. 6(b), the control plane protocol stack may be divided into Layer 1 (i.e., a PHY layer), Layer 2, Layer 3 (e.g., a radio resource control (RRC) layer), and a non-access stratum (NAS) layer.
- [78] The overall protocol stack architecture for the NR system might be similar to that of the LTE/LTE-A system, but some functionalities of the protocol stacks of the LTE/LTE-A system should be modified in the NR system in order to resolve the weakness or drawback of LTE. RAN WG2 for NR is in charge of the radio interface architecture and protocols. The new functionalities of the control plane include the following: on-demand system information delivery to reduce energy consumption and mitigate interference, two-level (i.e. Radio Resource Control (RRC) and Medium Access Control (MAC)) mobility to implement seamless handover, beam based mobility management to accommodate high frequency, RRC inactive state to reduce state transition latency and improve UE battery life. The new functionalities of the user plane aim at latency reduction by optimizing existing functionalities, such as concatenation and reordering relocation, and RLC out of order delivery. In addition, a new user plane AS protocol

layer named as Service Data Adaptation Protocol (SDAP) has been introduced to handle flow-based Quality of Service (QoS) framework in RAN, such as mapping between QoS flow and a data radio bearer, and QoS flow ID marking. Hereinafter the layer 2 according to the current agreements for NR is briefly discussed.

- [79] The layer 2 of NR is split into the following sublayers: Medium Access Control (MAC), Radio Link Control (RLC), Packet Data Convergence Protocol (PDCP) and Service Data Adaptation Protocol (SDAP). The physical layer offers to the MAC sublayer transport channels, the MAC sublayer offers to the RLC sublayer logical channels, the RLC sublayer offers to the PDCP sublayer RLC channels, the PDCP sublayer offers to the SDAP sublayer radio bearers, and the SDAP sublayer offers to 5GC QoS flows. Radio bearers are categorized into two groups: data radio bearers (DRB) for user plane data and signalling radio bearers (SRB) for control plane data.
- [80] The main services and functions of the MAC sublayer of NR include: mapping between logical channels and transport channels; multiplexing/demultiplexing of MAC SDUs belonging to one or different logical channels into/from transport blocks (TB) delivered to/from the physical layer on transport channels; scheduling information reporting; error correction through HARQ (one HARQ entity per carrier in case of carrier aggregation); priority handling between UEs by dynamic scheduling; priority handling between logical channels of one UE by logical channel prioritization; and padding. A single MAC entity can support one or multiple numerologies and/or transmission timings, and mapping restrictions in logical channel prioritisation controls which numerology and/or transmission timing a logical channel can use.
- [81] The RLC sublayer of NR supports three transmission modes: Transparent Mode (TM); Unacknowledged Mode (UM); Acknowledged Mode (AM). The RLC configuration is per logical channel with no dependency on numerologies and/or TTI durations, and ARQ can operate on any of the numerologies and/or TTI durations the logical channel is configured with. For SRB0, paging and broadcast system information, TM mode is used. For other SRBs AM mode used. For DRBs, either UM or AM mode are used. The main services and functions of the RLC sublayer depend on the transmission mode and include: transfer of upper layer PDUs; sequence numbering independent of the one in PDCP (UM and AM); error correction through ARQ (AM only); segmentation (AM and UM) and re-segmentation (AM only) of RLC SDUs; Re-assembly of SDU (AM and UM); duplicate detection (AM only); RLC SDU discard (AM and UM); RLC re-establishment; and protocol error detection (AM only). The ARQ within the RLC sublayer of NR has the following characteristics: ARQ re-transmits RLC PDUs or RLC PDU segments based on RLC status reports; polling for RLC status report is used when needed by RLC; and RLC receiver can also trigger RLC status report after detecting a missing RLC PDU or RLC PDU segment.

- [82] The main services and functions of the PDCP sublayer of NR for the user plane include: sequence numbering; header compression and decompression (ROHC only); transfer of user data; reordering and duplicate detection; PDCP PDU routing (in case of split bearers); retransmission of PDCP SDUs; ciphering, deciphering and integrity protection; PDCP SDU discard; PDCP re-establishment and data recovery for RLC AM; and duplication of PDCP PDUs. The main services and functions of the PDCP sublayer of NR for the control plane include: sequence numbering; ciphering, deciphering and integrity protection; transfer of control plane data; reordering and duplicate detection; and duplication of PDCP PDUs.
- [83] The main services and functions of SDAP include: mapping between a QoS flow and a data radio bearer; marking QoS flow ID (QFI) in both DL and UL packets. A single protocol entity of SDAP is configured for each individual PDU session. Compared to LTE's QoS framework, which is bearer-based, the 5G system adopts the QoS flow-based framework. The QoS flow-based framework enables flexible mapping of QoS flow to DRB by decoupling QoS flow and the radio bearer, allowing more flexible QoS characteristic configuration.
- [84] The main services and functions of RRC sublayer of NR include: broadcast of system information related to access stratum (AS) and non-access stratum (NAS); paging initiated by a 5GC or an NG-RAN; establishment, maintenance, and release of RRC connection between a UE and a NG-RAN (which further includes modification and release of carrier aggregation and further includes modification and release of the DC between an E-UTRAN and an NR or in the NR; a security function including key management; establishment, configuration, maintenance, and release of SRB(s) and DRB(s); handover and context transfer; UE cell selection and re-release and control of cell selection/re-selection; a mobility function including mobility between RATs; a QoS management function, UE measurement report, and report control; detection of radio link failure and discovery from radio link failure; and NAS message transfer to a UE from a NAS and NAS message transfer to the NAS from the UE.
- [85] Hereinafter, 5G communication system is briefly introduced.
- [86] Three main requirement categories for 5G include (1) a category of enhanced mobile broadband (eMBB), (2) a category of massive machine type communication (mMTC), and (3) a category of ultra-reliable and low latency communications (URLLC).
- [87] Partial use cases may require a plurality of categories for optimization and other use cases may focus only upon one key performance indicator (KPI). 5G supports such various use cases using a flexible and reliable method.
- [88] eMBB far surpasses basic mobile Internet access and covers abundant bidirectional work and media and entertainment applications in cloud and augmented reality. Data is one of 5G core motive forces and, in a 5G era, a dedicated voice service may not be

provided for the first time. In 5G, it is expected that voice will be simply processed as an application program using data connection provided by a communication system. Main causes for increased traffic volume are due to an increase in the size of content and an increase in the number of applications requiring high data transmission rate. A streaming service (of audio and video), conversational video, and mobile Internet access will be more widely used as more devices are connected to the Internet. These many application programs require connectivity of an always turned-on state in order to push real-time information and alarm for users. Cloud storage and applications are rapidly increasing in a mobile communication platform and may be applied to both work and entertainment. The cloud storage is a special use case which accelerates growth of uplink data transmission rate. 5G is also used for remote work of cloud. When a tactile interface is used, 5G demands much lower end-to-end latency to maintain user good experience. Entertainment, for example, cloud gaming and video streaming, is another core element which increases demand for mobile broadband capability. Entertainment is essential for a smartphone and a tablet in any place including high mobility environments such as a train, a vehicle, and an airplane. Other use cases are augmented reality for entertainment and information search. In this case, the augmented reality requires very low latency and instantaneous data volume.

[89] In addition, one of the most expected 5G use cases relates a function capable of smoothly connecting embedded sensors in all fields, i.e., mMTC. It is expected that the number of potential IoT devices will reach 204 hundred million up to the year of 2020. An industrial IoT is one of categories of performing a main role enabling a smart city, asset tracking, smart utility, agriculture, and security infrastructure through 5G.

[90] URLLC includes a new service that will change industry through remote control of main infrastructure and an ultra-reliable/available low-latency link such as a self-driving vehicle. A level of reliability and latency is essential to control a smart grid, automatize industry, achieve robotics, and control and adjust a drone.

[91] 5G is a means of providing streaming evaluated as a few hundred megabits per second to gigabits per second and may complement fiber-to-the-home (FTTH) and cable-based broadband (or DOCSIS). Such fast speed is needed to deliver TV in resolution of 4K or more (6K, 8K, and more), as well as virtual reality and augmented reality. Virtual reality (VR) and augmented reality (AR) applications include almost immersive sports games. A specific application program may require a special network configuration. For example, for VR games, gaming companies need to incorporate a core server into an edge network server of a network operator in order to minimize latency.

[92] Automotive is expected to be a new important motivated force in 5G together with many use cases for mobile communication for vehicles. For example, entertainment for

passengers requires high simultaneous capacity and mobile broadband with high mobility. This is because future users continue to expect connection of high quality regardless of their locations and speeds. Another use case of an automotive field is an AR dashboard. The AR dashboard causes a driver to identify an object in the dark in addition to an object seen from a front window and displays a distance from the object and a movement of the object by overlapping information talking to the driver. In the future, a wireless module enables communication between vehicles, information exchange between a vehicle and supporting infrastructure, and information exchange between a vehicle and other connected devices (e.g., devices accompanied by a pedestrian). A safety system guides alternative courses of a behavior so that a driver may drive more safely drive, thereby lowering the danger of an accident. The next stage will be a remotely controlled or self-driven vehicle. This requires very high reliability and very fast communication between different self-driven vehicles and between a vehicle and infrastructure. In the future, a self-driven vehicle will perform all driving activities and a driver will focus only upon abnormal traffic that the vehicle cannot identify. Technical requirements of a self-driven vehicle demand ultra-low latency and ultra-high reliability so that traffic safety is increased to a level that cannot be achieved by human being.

- [93] A smart city and a smart home/building mentioned as a smart society will be embedded in a high-density wireless sensor network. A distributed network of an intelligent sensor will identify conditions for costs and energy-efficient maintenance of a city or a home. Similar configurations may be performed for respective households. All of temperature sensors, window and heating controllers, burglar alarms, and home appliances are wirelessly connected. Many of these sensors are typically low in data transmission rate, power, and cost. However, real-time HD video may be demanded by a specific type of device to perform monitoring.
- [94] Consumption and distribution of energy including heat or gas is distributed at a higher level so that automated control of the distribution sensor network is demanded. The smart grid collects information and connects the sensors to each other using digital information and communication technology so as to act according to the collected information. Since this information may include behaviors of a supply company and a consumer, the smart grid may improve distribution of fuels such as electricity by a method having efficiency, reliability, economic feasibility, production sustainability, and automation. The smart grid may also be regarded as another sensor network having low latency.
- [95] Mission critical application (e.g. e-health) is one of 5G use scenarios. A health part contains many application programs capable of enjoying benefit of mobile communication. A communication system may support remote treatment that provides clinical

treatment in a faraway place. Remote treatment may aid in reducing a barrier against distance and improve access to medical services that cannot be continuously available in a faraway rural area. Remote treatment is also used to perform important treatment and save lives in an emergency situation. The wireless sensor network based on mobile communication may provide remote monitoring and sensors for parameters such as heart rate and blood pressure.

- [96] Wireless and mobile communication gradually becomes important in the field of an industrial application. Wiring is high in installation and maintenance cost. Therefore, a possibility of replacing a cable with reconstructible wireless links is an attractive opportunity in many industrial fields. However, in order to achieve this replacement, it is necessary for wireless connection to be established with latency, reliability, and capacity similar to those of the cable and management of wireless connection needs to be simplified. Low latency and a very low error probability are new requirements when connection to 5G is needed.
- [97] Logistics and freight tracking are important use cases for mobile communication that enables inventory and package tracking anywhere using a location-based information system. The use cases of logistics and freight typically demand low data rate but require location information with a wide range and reliability.
- [98] FIG. 7 illustrates a data flow example at a transmitting device in the NR system.
- [99] In FIG. 7, an RB denotes a radio bearer. Referring to FIG. 7, a transport block is generated by MAC by concatenating two RLC PDUs from RBx and one RLC PDU from RBy. In FIG. 7, the two RLC PDUs from RBx each corresponds to one IP packet (n and n+1) while the RLC PDU from RBy is a segment of an IP packet (m). In NR, a RLC SDU segment can be located in the beginning part of a MAC PDU and/or in the ending part of the MAC PDU. The MAC PDU is transmitted/received using radio resources through a physical layer to/from an external device.
- [100] FIG. 8 illustrates an example of a slot structure available in a new radio access technology (NR).
- [101] To reduce or minimize data transmission latency, in a 5G new RAT, a slot structure in which a control channel and a data channel are time-division-multiplexed is considered.
- [102] In the example of FIG. 8, the hatched area represents the transmission region of a DL control channel (e.g., PDCCH) carrying the DCI, and the black area represents the transmission region of a UL control channel (e.g., PUCCH) carrying the UCI. Here, the DCI is control information that the gNB transmits to the UE. The DCI may include information on cell configuration that the UE should know, DL specific information such as DL scheduling, and UL specific information such as UL grant. The UCI is control information that the UE transmits to the gNB. The UCI may include a HARQ

ACK/NACK report on the DL data, a CSI (Channel Status Information) report on the DL channel status, and a scheduling request (SR).

- [103] In the example of FIG. 8, the region of symbols from symbol index 1 to symbol index 12 may be used for transmission of a physical channel (e.g., a PDSCH) carrying downlink data, or may be used for transmission of a physical channel (e.g., PUSCH) carrying uplink data. According to the slot structure of FIG. 8, DL transmission and UL transmission may be sequentially performed in one slot, and thus transmission/reception of DL data and reception/transmission of UL ACK/NACK for the DL data may be performed in one slot. As a result, the time taken to retransmit data when a data transmission error occurs may be reduced, thereby minimizing the latency of final data transmission.
- [104] In such a slot structure, a time gap is needed for the process of switching from the transmission mode to the reception mode or from the reception mode to the transmission mode of the gNB and UE. On behalf of the process of switching between the transmission mode and the reception mode, some OFDM symbols at the time of switching from DL to UL in the slot structure are set as a guard period (GP).
- [105] In the legacy LTE/LTE-A system, a DL control channel is time-division-multiplexed with a data channel and a PDCCH, which is a control channel, is transmitted throughout an entire system band. However, in the new RAT, it is expected that a bandwidth of one system reaches approximately a minimum of 100 MHz and it is difficult to distribute the control channel throughout the entire band for transmission of the control channel. For data transmission/reception of a UE, if the entire band is monitored to receive the DL control channel, this may cause increase in battery consumption of the UE and deterioration in efficiency. Accordingly, in the present disclosure, the DL control channel may be locally transmitted or distributively transmitted in a partial frequency band in a system band, i.e., a channel band.
- [106] In the NR system, the basic transmission unit is a slot. A duration of the slot includes 14 symbols having a normal cyclic prefix (CP) or 12 symbols having an extended CP. In addition, the slot is scaled in time as a function of a used subcarrier spacing.
- [107] Hereinafter, Logical channel prioritization in the NR system is described.
- [108] The Logical Channel Prioritization procedure is applied when a new transmission is performed. RRC controls the scheduling of uplink data by signalling for each logical channel: priority where an increasing priority value indicates a lower priority level, prioritisedBitRate which sets the Prioritized Bit Rate (PBR), bucketSizeDuration which sets the Bucket Size Duration (BSD).
- [109] The MAC entity shall maintain a variable B_j for each logical channel j . B_j shall be initialized to zero when the related logical channel is established, and incremented by the product $PBR \times TTI$ duration for each TTI, where PBR is Prioritized Bit Rate of

logical channel j . However, the value of B_j can never exceed the bucket size and if the value of B_j is larger than the bucket size of logical channel j , it shall be set to the bucket size. The bucket size of a logical channel is equal to $PBR \times BSD$, where PBR and BSD are configured by upper layers.

- [110] The MAC entity shall perform the following Logical Channel Prioritization procedure when a new transmission is performed:
- [111] - The MAC entity shall allocate resources to the logical channels in the following steps 1-3:
- [112] Step 1: All the logical channels with $B_j > 0$ are allocated resources in a decreasing priority order. If the PBR of a logical channel is set to “infinity”, the MAC entity shall allocate resources for all the data that is available for transmission on the logical channel before meeting the PBR of the lower priority logical channel(s);
- [113] Step 2: the MAC entity shall decrement B_j by the total size of MAC SDUs served to logical channel j in Step 1. Especially, the value of B_j can be negative.
- [114] Step 3: if any resources remain, all the logical channels are served in a strict decreasing priority order (regardless of the value of B_j) until either the data for that logical channel or the UL grant is exhausted, whichever comes first. Logical channels configured with equal priority should be served equally.
- [115] - The UE shall also follow the rules (1)-(5) below during the scheduling procedures above
- [116] (1) the UE should not segment an RLC SDU (or partially transmitted SDU or re-transmitted RLC PDU) if the whole SDU (or partially transmitted SDU or re-transmitted RLC PDU) fits into the remaining resources of the associated MAC entity.
- [117] (2) if the UE segments an RLC SDU from the logical channel, it shall maximize the size of the segment to fill the grant of the associated MAC entity as much as possible.
- [118] (3) the UE should maximise the transmission of data.
- [119] (4) if the MAC entity is given an UL grant size that is equal to or larger than 4 bytes while having data available for transmission, the MAC entity shall not transmit only padding BSR and/or padding (unless the UL grant size is less than 7 bytes and an AMD PDU segment needs to be transmitted).
- [120] (5) for transmissions on serving cells operating according to Frame Structure Type 3, the MAC entity shall only consider logical channels for which $l_{aa-UL-Allowed}$ has been configured.
- [121] The MAC entity shall not transmit data for a logical channel corresponding to a radio bearer that is suspended .
- [122] If the MAC PDU includes only the MAC CE for padding BSR or periodic BSR with zero MAC SDUs and there is no aperiodic CSI requested for this TTI [2], the MAC entity shall not generate a MAC PDU for the HARQ entity in case the MAC entity is

configured with skipUplinkTxDynamic and the grant indicated to the HARQ entity was addressed to a C-RNTI or in case the MAC entity is configured with skipUplinkTxSPS and the grant indicated to the HARQ entity is a configured uplink grant.

[123] For the Logical Channel Prioritization procedure, the MAC entity shall take into account the following relative priority in decreasing order:

[124] a) MAC control element for C-RNTI or data from UL-CCCH;

[125] b) MAC control element for DPR;

[126] c) MAC control element for SPS confirmation;

[127] d) MAC control element for BSR, with exception of BSR included for padding;

[128] e) MAC control element for PHR, Extended PHR, or Dual Connectivity PHR;

[129] f) MAC control element for Sidelink BSR, with exception of Sidelink BSR included for padding;

[130] g) data from any Logical Channel, except data from UL-CCCH;

[131] h) MAC control element for Recommended bit rate query;

[132] i) MAC control element for BSR included for padding;

[133] j) MAC control element for Sidelink BSR included for padding.

[134] As mentioned above, resource allocation to the logical channels in Logical Channel Prioritization (LCP) procedure is performed based on a priority order and B_j value for each logical channel j .

[135] Firstly, in a first round, when a UE receives an uplink grant and generates the MAC PDU to be transmitted, the UE selects the logical channels which satisfy the mapping restrictions for the uplink grant. Among the selected logical channels, only the logical channels with $B_j > 0$ are firstly allocated the resources by their respective Prioritized Bit Rates (PBRs) in a decreasing priority order, and B_j value is decremented by the size of MAC SDU served to the logical channel j .

[136] In a second round, if any resources remain, all the selected logical channel above are served in a strict priority order regardless of the value of B_j until either the data for that logical channel or the uplink grant is exhausted. Thus, if the amount of data for the logical channel with higher priority is larger than the size of the remaining uplink grant, the logical channel with lower priority cannot have a chance to be served even though the higher priority logical channel has a negative value of B_j , which implies that the corresponding logical channel has exhausted all of its token to guarantee its QoS.

[137] Meanwhile, according to TS 23.501, 5G QoS characteristics define the Packet Delay Budget (PDB) for each QoS flow and, for a delay critical GBR QoS flow, a packet delayed more than PDB is counted as lost if the transmitted data burst is less than Maximum Data Burst Volume (MDBV) within the period of PDB and the QoS flow is not exceeding the Guaranteed Flow Bit Rate (GFBR). On the other hand, if the delay

critical GBR QoS flow does not comply with the MDBV and GFBR requirements, delayed packets are not counted as lost.

[138] Therefore, the UE does not need to transmit the data burst exceeding the MDBV for a certain QoS flow within the period of PDB and no other flows should not be sacrificed due to the QoS flows which do not comply with the MDBV requirement.

[139] In prior art, one simple way to limit the transmitted data volume for a certain flow to the MDBV within the period of PDB is to configure the corresponding logical channel with $PBR = MDBV/PDB$ and $BSD = PDB$. However, as we stated above, since the second round of the resource allocation in LCP procedure does not consider the value of B_j but does strictly depend on the priority order of the logical channels, more resources than MDBV can be allocated within a period of PDB to a certain QoS flow with higher priority in the second round, which causes other delay critical QoS flows to be exhausted. Thus, by simply setting $PBR = MDBV/PDB$ and $BSD = PDB$, the delay critical QoS flows complying with the MDBV requirement cannot be protected from other delay critical QoS flows violating the MDBV requirement.

[140] Therefore, new mechanism is needed to guarantee the PDB and PER requirements for all delay critical QoS flows that do not exceed the MDBV even when there are other delay critical QoS flows exceeding the MDBV.

[141] In this invention, the resource allocation in the LCP procedure is divided into three rounds.

[142] - First round: The first round includes the resource allocation to the logical channels having a positive token value B_j by the amount of their PBRs and the decrement of the corresponding token values B_j of each logical channel.

[143] - Second round: After completing the first round, the second round includes the allocation of remaining resources to the logical channels still having a positive token value in a decreasing priority order until B_j becomes zero for the logical channel or all remaining resources are consumed.

[144] Third round: The third round refers to the allocation of remaining resources to all logical channels regardless of token value B_j of each logical channel if resource still remains after completing the second round.

[145] In the second round, a UE does not preferably allocate resources to a logical channel of which token value B_j is less than or equal to zero even if the logical channels have higher priority than a logical channel of which token value B_j is greater than zero. In other words, the UE prioritizes a logical channel with positive token value than a logical channel with negative token value in the second round of the LCP procedure.

[146] A UE is configured with one or more logical channels by a network. For this, the UE receives a logical channel configuration information including,

[147] - A logical channel identifier (LCHID); and/or

- [148] - A prioritized bit rate (PBR); and/or
- [149] - A bucket size duration (BSD); and/or
- [150] - The priority value (PRIORITY);
- [151] A token value B_j of each logical channel j is the UE variable used for the LCP procedure. The UE initialize B_j of a logical channel j to zero when the logical channel is established. The UE increments B_j by the product $PBR \times T$ before every instance of the LCP procedure, where T is the time elapsed since B_j was last incremented. If the value of B_j is greater than the bucket size (i.e. $PBR \times BSD$), the UE sets B_j to the bucket size.
- [152] If the UE receives an uplink grant, the UE generates a MAC PDU to be transmitted by using the uplink grant as follows 1)-4):
- [153] 1) The UE selects the logical channels satisfying the mapping restrictions for the uplink grant, i.e., allowed logical channels.
- [154] 2) The UE performs the first round of the LCP procedure. More specifically, among the allowed logical channels, the UE selects a logical channel with $B_j > 0$ and allocates resources to the selected logical channels by their PBR values in a decreasing priority order. Then, the UE decrements B_j of each logical channel by the amount of resources served to the logical channel above.
- [155] 3) If any resources remain after the first round, the UE starts the second round of the resource allocation.
- [156] That is, among the allowed logical channels, the UE selects a logical channel with $B_j > 0$ and allocates resources to the selected logical channels in decreasing priority order until one of the following condition is met whichever comes first. Thus, B_j of the selected logical channel becomes zero.
- [157] Alternatively, if B_j of the logical channel becomes zero, the UE doesn't allocate more resources to the logical channel in the second round of the LCP procedure even if there is remaining data available for the logical channel and there is remaining resources of the uplink grant. In other words, the UE stops allocating resources to the selected logical channel if B_j of the logical channel equals to zero in the second round. In this case, available data of the selected logical channel are all included in resources of the uplink grant, or the remaining resources of the uplink grant are all exhausted.
- [158] Then, the UE decrements B_j of each logical channel by the amount of resources served to the logical channel above.
- [159] 4) If any resources remain after the second round, the UE starts the third round of the resource allocation. Among the allowed logical channels, the UE allocates resources to all logical channels in a strict decreasing priority order regardless of the value of B_j until either the data for that logical channel or the uplink grant is exhausted, whichever comes first. Logical channels configured with equal priority should be served equally.

[160] Hereinafter, the present invention will be described in more detail with reference to FIGs 9-14.

[161] FIG. 9 shows an example of configuration of logical channels according to the embodiment of the present invention.

[162] Referring to FIG. 9, at a time point (t) is 0, a network configures a UE with three logical channels by sending a configuration information followings:

[163] - Logical Channel 1 : LCID=1, PBR=kBps128, BSD=ms50, PRIORITY=1;

[164] - Logical Channel 2 : LCID=2, PBR=kBps128, BSD=ms50, PRIORITY=2;

[165] - Logical Channel 3 : LCID=3, PBR=kBps64, BSD=ms100, PRIORITY=3.

[166] Then, the UE configures three logical channels as indicated by the configuration information and initializes their B_j values to zero, i.e. $B_1=0$, $B_2=0$, $B_3=0$. Bucket sizes of the logical channels are respectively calculated as follows:

[167] - $\text{bucketSize}_1 = 128 \times 50 = 6400$ Bytes;

[168] - $\text{bucketSize}_2 = 128 \times 50 = 6400$ Bytes;

[169] - $\text{bucketSize}_3 = 64 \times 100 = 6400$ Bytes.

[170] FIG. 10 shows an example of buffer status and B_j of logical channels according to the embodiment of the present invention.

[171] Referring to FIG. 10, at the time point (t) is 25ms, the network sends an uplink grant for a new transmission to the UE and the buffer status (BS) and B_j values of Logical Channels 1, 2 and 3 is as follows:

[172] - $BS_1 = 8000$ Bytes, $BS_2 = 3000$ Bytes, $BS_3 = 3000$ Bytes;

[173] - $B_1 = 128 \times 25 = 3200$ Bytes, $B_2 = 128 \times 25 = 3200$ Bytes, $B_3 = 64 \times 50 = 1600$ Bytes.

[174] FIG. 11 shows an example of a first round of resource allocation according to the embodiment of the present invention.

[175] FIG. 12 and FIG. 13 show examples of a second round of resource allocation according to the embodiment of the present invention.

[176] Referring to FIG. 11, as the first round of resource allocation, the UE generates the MAC PDU to be transmitted via the uplink grant including data from Logical Channel 1, Logical Channel 2, and Logical Channel 3, and the MAC PDU has a room of 10000 Bytes for data from the three logical channels. The UE allocates the resources as follows:

[177] - Step 1

[178] The UE allocates the resources to Logical Channels 1, 2 and 3 by their PBR values in a decreasing priority order.

[179] - Step 2.

[180] The UE decrements B_j of Logical Channels 1, 2 and 3 by the amount of resources served to each logical channel above.

- [181] - Step 3.
- [182] Referring to FIG. 12, as the second round of resource allocation, the UE allocates the remaining resources of 9680 Bytes to Logical Channels 1, 2 and 3 by their B_j values in a decreasing priority order. Logical Channel 1, which has the highest priority, is served first.
- [183] - Step 4.
- [184] Referring to FIG. 13, as the second round of resource allocation, since the amount of data for Logical Channel 2 is less than its B_j value, the UE allocates the resource to Logical Channel 2 only as much as the amount of data it has. Finally, Logical Channel 3 is served.
- [185] - Step 5.
- [186] Referring to FIG. 14, as the third round of resource allocation, the UE allocates the remaining resources of 2200 Bytes to Logical Channel 1.
- [187] FIG. 15 is a block diagram illustrating an example of elements of a transmitting device 100 and a receiving device 200 according to some implementations of the present disclosure.
- [188] The transmitting device 100 and the receiving device 200 respectively include transceivers 13 and 23 capable of transmitting and receiving radio signals carrying information, data, signals, and/or messages, memories 12 and 22 for storing information related to communication in a wireless communication system, and processors 11 and 21 operationally connected to elements such as the transceivers 13 and 23 and the memories 12 and 22 to control the elements and configured to control the memories 12 and 22 and/or the transceivers 13 and 23 so that a corresponding device may perform at least one of the above-described implementations of the present disclosure.
- [189] The memories 12 and 22 may store programs for processing and controlling the processors 11 and 21 and may temporarily store input/output information. The memories 12 and 22 may be used as buffers. The buffers at each protocol layer (e.g. PDCP, RLC, MAC) are parts of the memories 12 and 22.
- [190] The processors 11 and 21 generally control the overall operation of various modules in the transmitting device and the receiving device. Especially, the processors 11 and 21 may perform various control functions to implement the present disclosure. For example, the operations occurring at the protocol stacks (e.g. PDCP, RLC, MAC and PHY layers) according to the present disclosure may be performed by the processors 11 and 21. The protocol stacks performing operations of the present disclosure may be parts of the processors 11 and 21.
- [191] The processors 11 and 21 may be referred to as controllers, microcontrollers, microprocessors, or microcomputers. The processors 11 and 21 may be implemented by hardware, firmware, software, or a combination thereof. In a hardware configuration,

application specific integrated circuits (ASICs), digital signal processors (DSPs), digital signal processing devices (DSPDs), programmable logic devices (PLDs), or field programmable gate arrays (FPGAs) may be included in the processors 11 and 21. The present disclosure may be implemented using firmware or software, and the firmware or software may be configured to include modules, procedures, functions, etc. performing the functions or operations of the present disclosure. Firmware or software configured to perform the present disclosure may be included in the processors 11 and 21 or stored in the memories 12 and 22 so as to be driven by the processors 11 and 21.

[192] The processor 11 of the transmitting device 100 performs predetermined coding and modulation for a signal and/or data scheduled to be transmitted to the outside by the processor 11 or a scheduler connected with the processor 11, and then transfers the coded and modulated data to the transceiver 13. For example, the processor 11 converts a data stream to be transmitted into K layers through demultiplexing, channel coding, scrambling, and modulation. The coded data stream is also referred to as a codeword and is equivalent to a transport block which is a data block provided by a MAC layer. One transport block (TB) is coded into one codeword and each codeword is transmitted to the receiving device in the form of one or more layers. For frequency up-conversion, the transceiver 13 may include an oscillator. The transceiver 13 may include N_t (where N_t is a positive integer) transmission antennas.

[193] A signal processing process of the receiving device 200 is the reverse of the signal processing process of the transmitting device 100. Under control of the processor 21, the transceiver 23 of the receiving device 200 receives radio signals transmitted by the transmitting device 100. The transceiver 23 may include N_r (where N_r is a positive integer) receive antennas and frequency down-converts each signal received through receive antennas into a baseband signal. The processor 21 decodes and demodulates the radio signals received through the reception antennas and restores data that the transmitting device 100 intended to transmit.

[194] The transceivers 13 and 23 include one or more antennas. An antenna performs a function for transmitting signals processed by the transceivers 13 and 23 to the exterior or receiving radio signals from the exterior to transfer the radio signals to the transceivers 13 and 23. The antenna may also be called an antenna port. Each antenna may correspond to one physical antenna or may be configured by a combination of more than one physical antenna element. The signal transmitted from each antenna cannot be further deconstructed by the receiving device 200. An RS transmitted through a corresponding antenna defines an antenna from the view point of the receiving device 200 and enables the receiving device 200 to derive channel estimation for the antenna, irrespective of whether the channel represents a single radio channel

from one physical antenna or a composite channel from a plurality of physical antenna elements including the antenna. That is, an antenna is defined such that a channel carrying a symbol of the antenna can be obtained from a channel carrying another symbol of the same antenna. An transceiver supporting a MIMO function of transmitting and receiving data using a plurality of antennas may be connected to two or more antennas. The transceivers 13 and 23 may be referred to as radio frequency (RF) units.

[195] In the implementations of the present disclosure, a UE operates as the transmitting device 100 in UL and as the receiving device 200 in DL. In the implementations of the present disclosure, a BS operates as the receiving device 200 in UL and as the transmitting device 100 in DL. Hereinafter, a processor, a transceiver, and a memory included in the UE will be referred to as a UE processor, a UE transceiver, and a UE memory, respectively, and a processor, a transceiver, and a memory included in the BS will be referred to as a BS processor, a BS transceiver, and a BS memory, respectively.

[196] The UE processor can be configured to operate according to the present disclosure, or control the UE transceiver to receive or transmit signals according to the present disclosure. The BS processor can be configured to operate according to the present disclosure, or control the BS transceiver to receive or transmit signals according to the present disclosure.

[197] The processor 11 (at a UE and/or at a BS) checks whether there is a UL grant or DL assignment for a serving cell in a time unit. If there is a UL grant or DL assignment for the serving cell in the time unit, the processor 11 checks whether a data unit is actually present on the UL grant or DL assignment in the time unit, in order to determine whether to restart a deactivation timer associated with the serving cell which has been started. The processor 11 restarts the deactivation timer associated with the serving cell in the time unit if there is a data unit present on the UL grant or DL assignment in the time unit. The processor 11 does not restart the deactivation timer associated with the serving cell in the time unit if there is no data unit present on the UL grant or DL assignment in the time unit, unless another condition that the processor 11 should restart the deactivation timer is satisfied. The processor 11 does not restart the deactivation timer associated with the serving cell in the time unit if there is no data unit present on the UL grant or DL assignment in the time unit and if an activation command for activating the serving cell is not present in the time unit. The processor 11 may be configured to check whether a data unit is actually present on the UL grant or DL assignment on the serving cell in the time unit in order to determine whether to restart the deactivation timer of the serving cell, if the UL grant or DL assignment is a configured grant/assignment which is configured by RRC to occur periodically on the serving cell. The processor 11 may be configured to check whether a data unit is actually present on

the UL grant or DL assignment on the serving cell in the time unit in order to determine whether to restart the deactivation timer of the serving cell, if the UL grant or the DL assignment is a dynamic grant/assignment which is indicated by a PDCCH. The processor 11 may be configured to check whether a data unit is actually present on the UL grant or DL assignment on the serving cell in the time unit in order to determine whether to restart the deactivation timer of the serving cell, if the serving cell is a SCell of the UE. The processor 11 (at the UE and/or the BS) deactivates the serving cell upon expiry of the deactivation timer associated with the serving cell.

[198] In the present disclosure, a user equipment (UE) may include, for example, a cellular phone, a smartphone, a laptop computer, a digital broadcast terminal, a personal digital assistant (PDA), a portable multimedia player (PMP), a navigation system, a slate personal computer (PC), a tablet PC, an ultrabook, a wearable device (e.g., a smartwatch, a smartglass, or head mounted display (HMD)), and the like. The HMD may be, for example, a type of display device that is worn on the head. For example, the HMD may be used to implement virtual reality (VR), augmented reality (AR), or mixed reality (MR).

[199] In the present disclosure, an unmanned aerial vehicle (UAV) may be, for example, an aircraft without a human being onboard, which aviates by a wireless control signal. In the present disclosure, a VR device may include, for example, a device for implementing an object or a background of the virtual world. The AR device may include, for example, a device implemented by connecting an object or a background of the virtual world to an object or a background of the real world. In the present disclosure, a MR device may include, for example, a device implemented by merging an object or a background of the virtual world into an object or a background of the real world. In the present disclosure, a hologram device may include, for example, a device for implementing a stereoscopic image of 360 degrees by recording and reproducing stereoscopic information, using an interference phenomenon of light generated when two laser lights called holography meet. The public safety device may include, for example, an image relay device or an image device that is wearable on the body of a user. In the present disclosure, a MTC device and a IoT device may be, for example, devices that do not require direct human intervention or manipulation. For example, the MTC device and the IoT device may include smartmeters, vending machines, thermometers, smartbulbs, door locks, or various sensors. In the present disclosure, a medical device may be, for example, a device used for the purpose of diagnosing, treating, relieving, curing, or preventing disease. For example, the medical device may be a device used for the purpose of diagnosing, treating, relieving, or correcting injury or impairment. For example, the medical device may be a device used for the purpose of inspecting, replacing, or modifying a structure or a function. For

example, the medical device may be a device used for the purpose of adjusting pregnancy. For example, the medical device may include a device for treatment, a device for operation, a device for (in vitro) diagnosis, a hearing aid, or a device for procedure. In the present disclosure, a security device may be, for example, a device installed to prevent a danger that may arise and to maintain safety. For example, the security device may be a camera, a CCTV, a recorder, or a black box. In the present disclosure, a FinTech device may be, for example, a device capable of providing a financial service such as mobile payment. For example, the FinTech device may include a payment device or a point of sales (POS) system. The weather/environment device may include, for example, a device for monitoring or predicting a weather/environment.

[200] As described above, the detailed description of the preferred implementations of the present disclosure has been given to enable those skilled in the art to implement and practice the disclosure. Although the disclosure has been described with reference to exemplary implementations, those skilled in the art will appreciate that various modifications and variations can be made in the present disclosure without departing from the spirit or scope of the disclosure described in the appended claims. Accordingly, the disclosure should not be limited to the specific implementations described herein, but should be accorded the broadest scope consistent with the principles and novel features disclosed herein.

Industrial Applicability

[201] The implementations of the present disclosure are applicable to a network node (e.g., BS), a UE, or other devices in a wireless communication system.

Claims

- [Claim 1] A method for allocating resources by a transmission end in a wireless communication system, the method comprising:
receiving an uplink grant for first and second logical channels;
generating a data unit including data from the first and second logical channels based on the uplink grant; and
transmitting the data unit to a network,
wherein generating the data unit comprises:
allocating resources indicated by the uplink grant to first and second logical channels having positive token values by amount of corresponding prioritized bit rates (PBRs) with decrementing corresponding token values of each logical channel by amount of allocated resources;
if a token value of the first logical channel is greater than 0, allocating remaining resources to the first logical channel until the token value of the first logical channel becomes zero; and
if a token value of the second logical channel is greater than 0, allocating remaining resources to the second logical channel until the token value of the second logical channel becomes zero.
- [Claim 2] The method of claim 1, further comprising:
if remaining resources are exist and remaining data from the first logical channel exists after the token value of the second logical channel becomes zero, allocating remaining resources to the first logical channel regardless of the token value of the first logical channel until the resources indicated by the uplink grant are exhausted.
- [Claim 3] The method of claim 1, wherein a priority of the first logical channel is higher than a priority of the second logical channel.
- [Claim 4] The method of claim 1, wherein if the token value of the first logical channel is greater than 0 and if amount of remaining data from the first logical channel is less than the token value of the first logical channel, the remaining resources are allocated to the first logical channel by the amount of remaining data from the first logical channel.
- [Claim 5] The method of claim 4, wherein if the token value of the second logical channel is greater than 0 and if amount of remaining data from the second logical channel is less than the token value of the second logical channel, the remaining resources are allocated to the second logical channel by the amount of remaining data from the second logical channel.

- [Claim 6] An apparatus for wireless communications, comprising:
a radio frequency (RF) module;
a memory; and
at least one processor coupled to the memory and the RF module,
wherein the at least one processor is configured to:
receive an uplink grant for first and second logical channels;
generate a data unit including data from the first and second logical
channels based on the uplink grant; and
transmit the data unit to a network,
wherein the at least one processor is further configured to:
allocate resources indicated by the uplink grant to first and second
logical channels having positive token values by amount of corre-
sponding prioritized bit rates (PBRs) with decrementing corresponding
token values of each logical channel by amount of allocated resources;
if a token value of the first logical channel is greater than 0, allocate
remaining resources to the first logical channel until the token value of
the first logical channel becomes zero; and
if a token value of the second logical channel is greater than 0, allocate
remaining resources to the second logical channel until the token value
of the second logical channel becomes zero.
- [Claim 7] The apparatus of claim 6, wherein, if remaining resources are exist and
remaining data from the first logical channel exists after the token value
of the second logical channel becomes zero, the at least one processor
is further configured to allocate remaining resources to the first logical
channel regardless of the token value of the first logical channel until
the resources indicated by the uplink grant are exhausted.
- [Claim 8] The apparatus of claim 6, wherein a priority of the first logical channel
is higher than a priority of the second logical channel.
- [Claim 9] The apparatus of claim 6, wherein if the token value of the first logical
channel is greater than 0 and if amount of remaining data from the first
logical channel is less than the token value of the first logical channel,
the at least one processor is further configured to allocate the remaining
resources to the first logical channel by the amount of remaining data
from the first logical channel.
- [Claim 10] The apparatus of claim 9, wherein if the token value of the second
logical channel is greater than 0 and if amount of remaining data from
the second logical channel is less than the token value of the second
logical channel, the at least one processor is further configured to

allocate the remaining resources to the second logical channel by the amount of remaining data from the second logical channel.

[Claim 11]

The apparatus of claim 6, wherein the at least one processor is further configured to implement at least one advanced driver assistance system (ADAS) function based on signals that control the UE.

[Fig. 1]

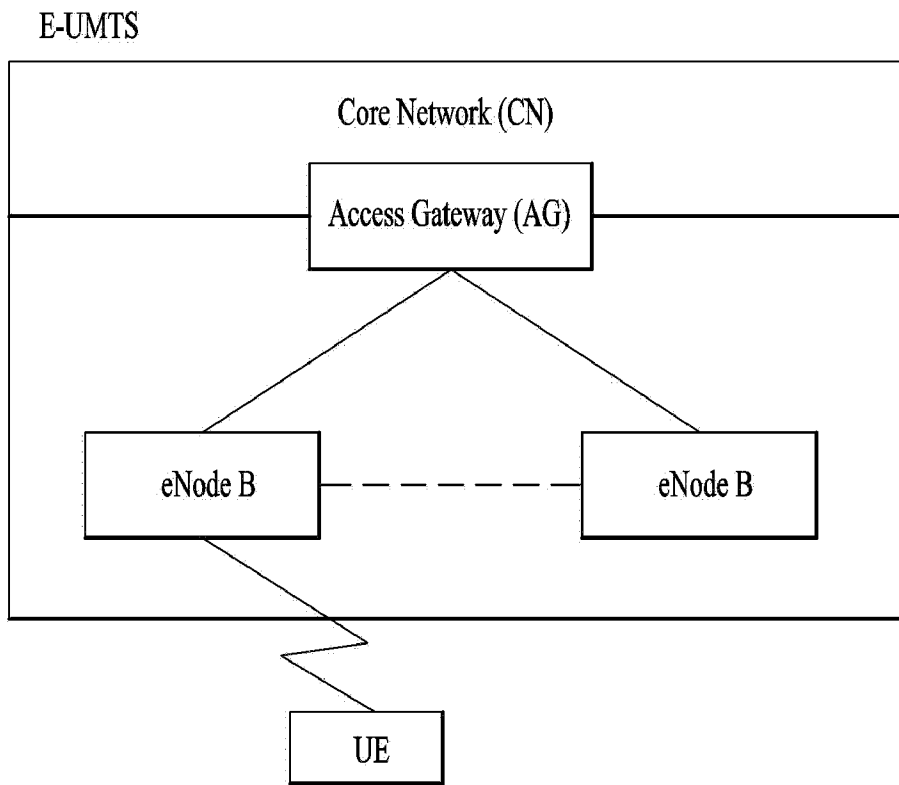

[Fig. 2]

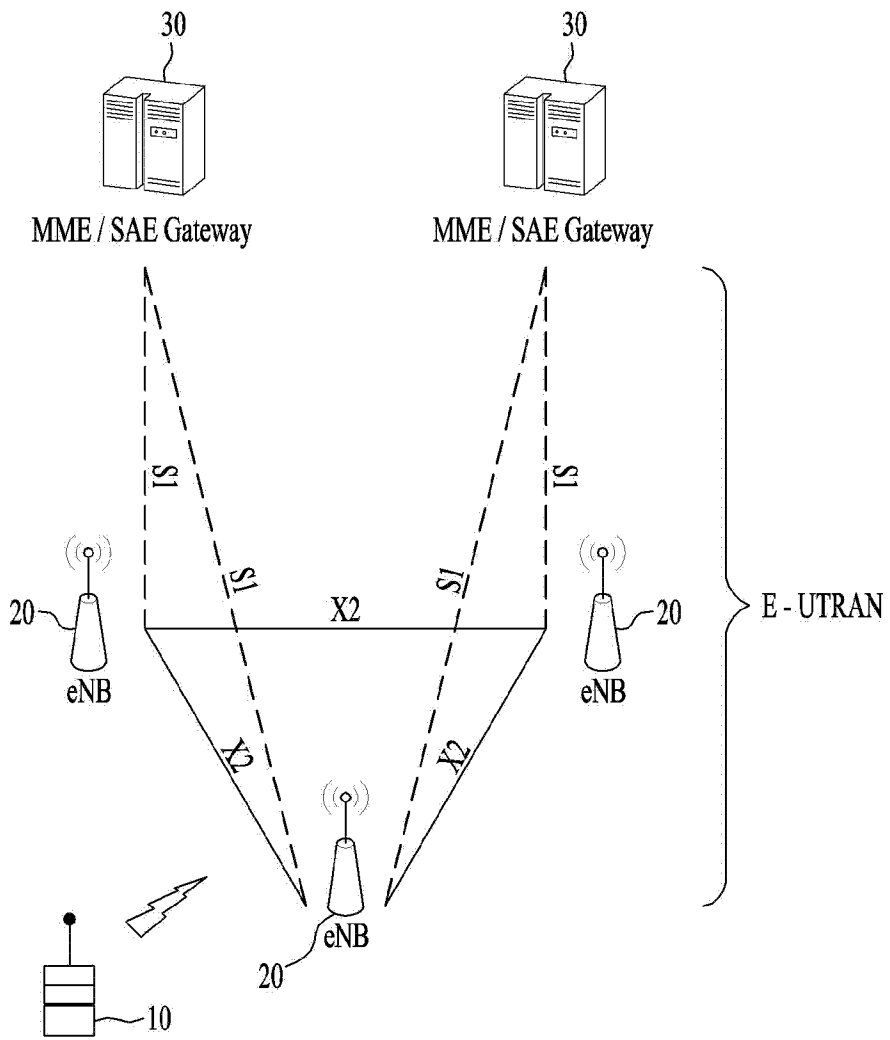

[Fig. 3]

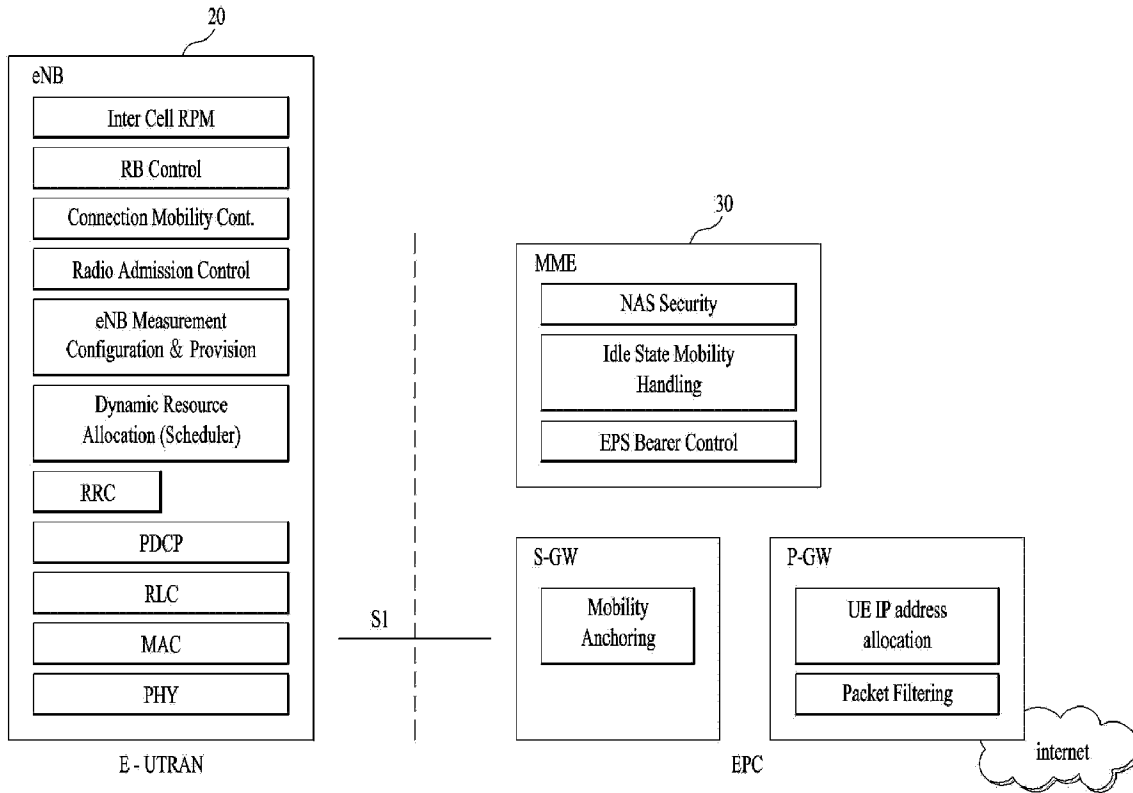

[Fig. 4]

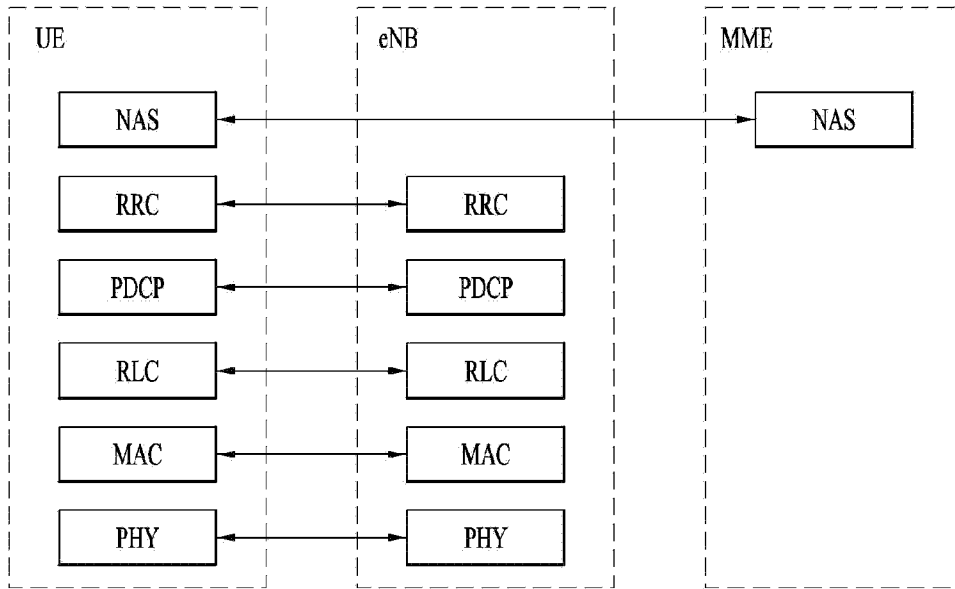

(a) Control-Plane Protocol Stack

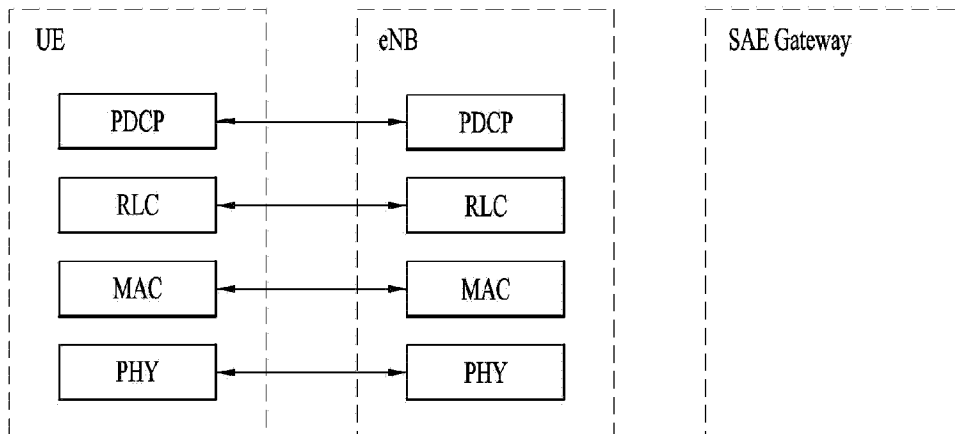

(b) User-Plane Protocol Stack

[Fig. 5]

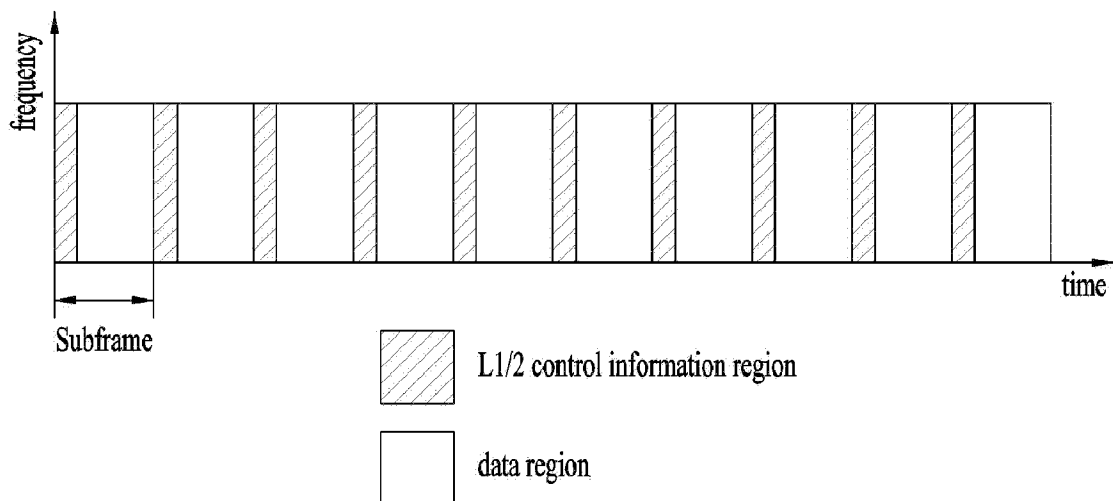

[Fig. 6]

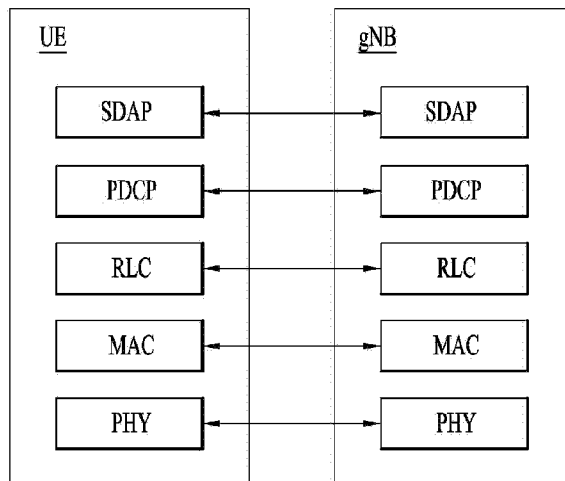

(a)

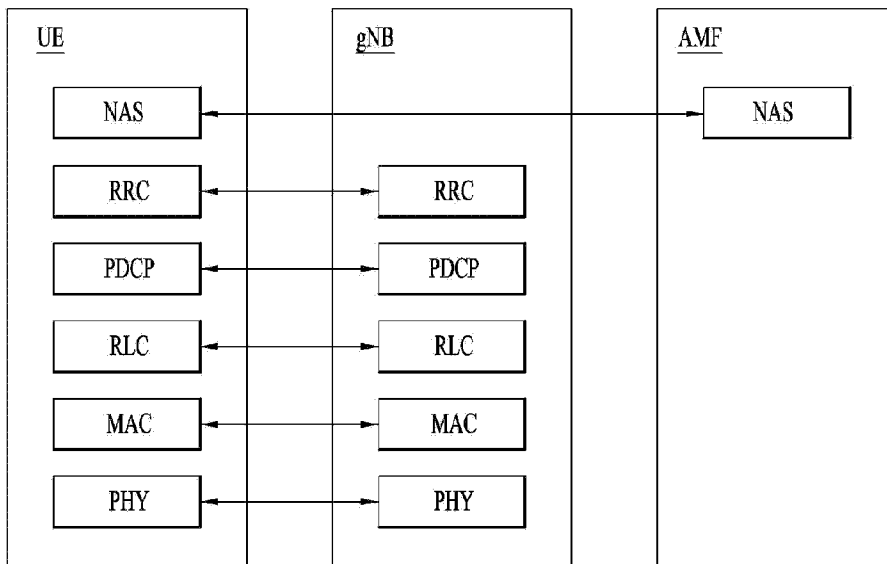

(b)

[Fig. 7]

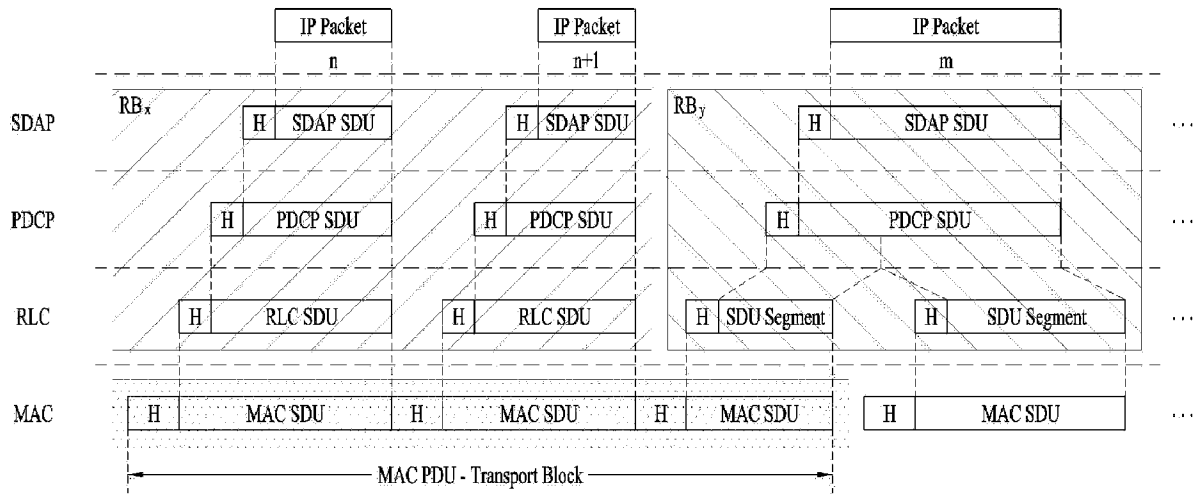

[Fig. 8]

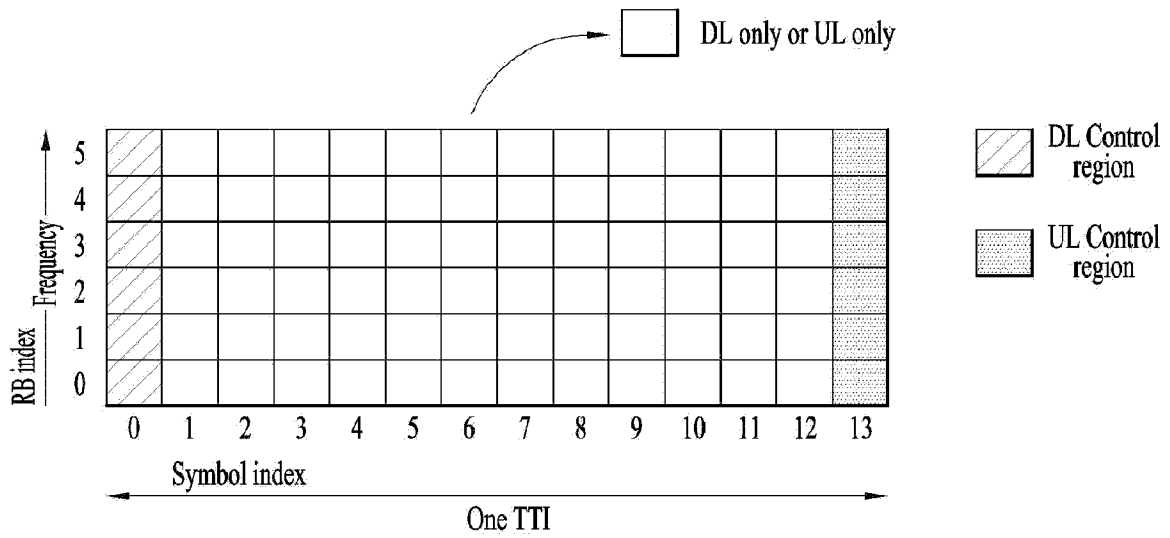

[Fig. 9]

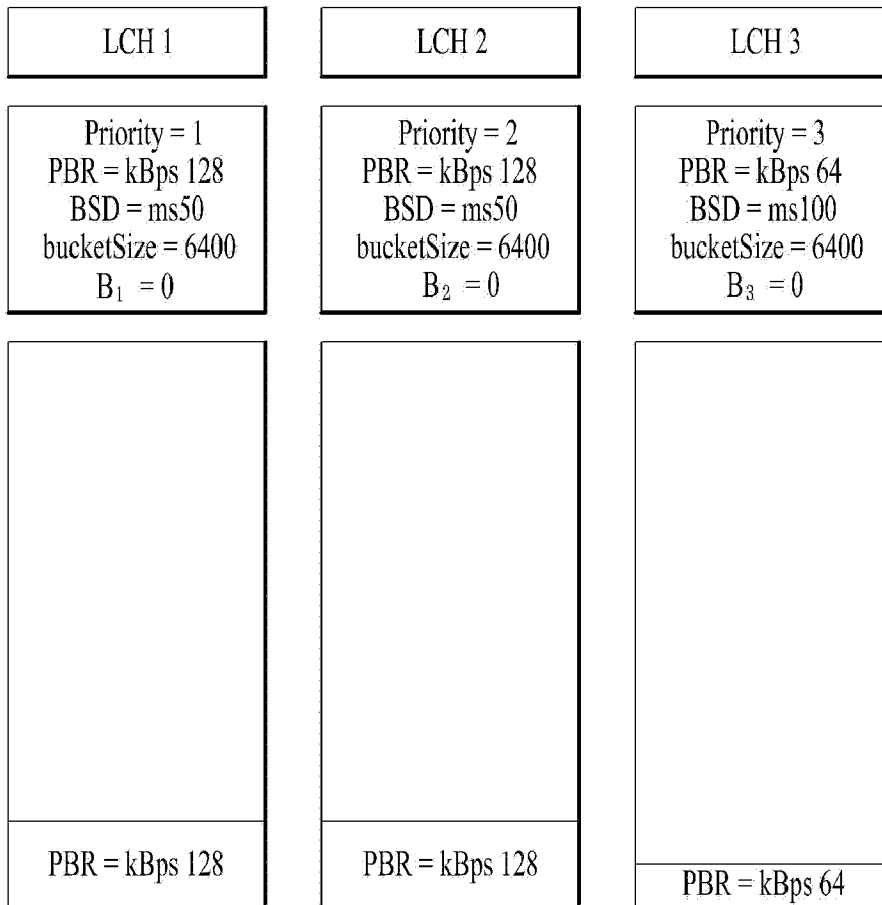

[Fig. 10]

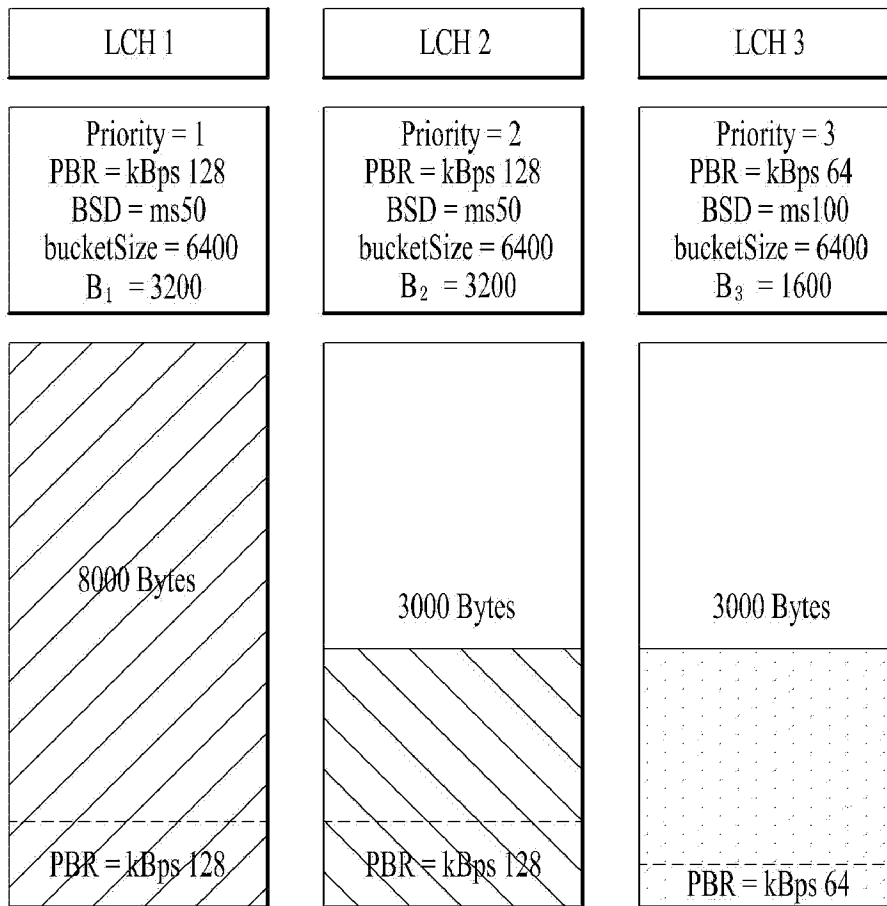

[Fig. 11]

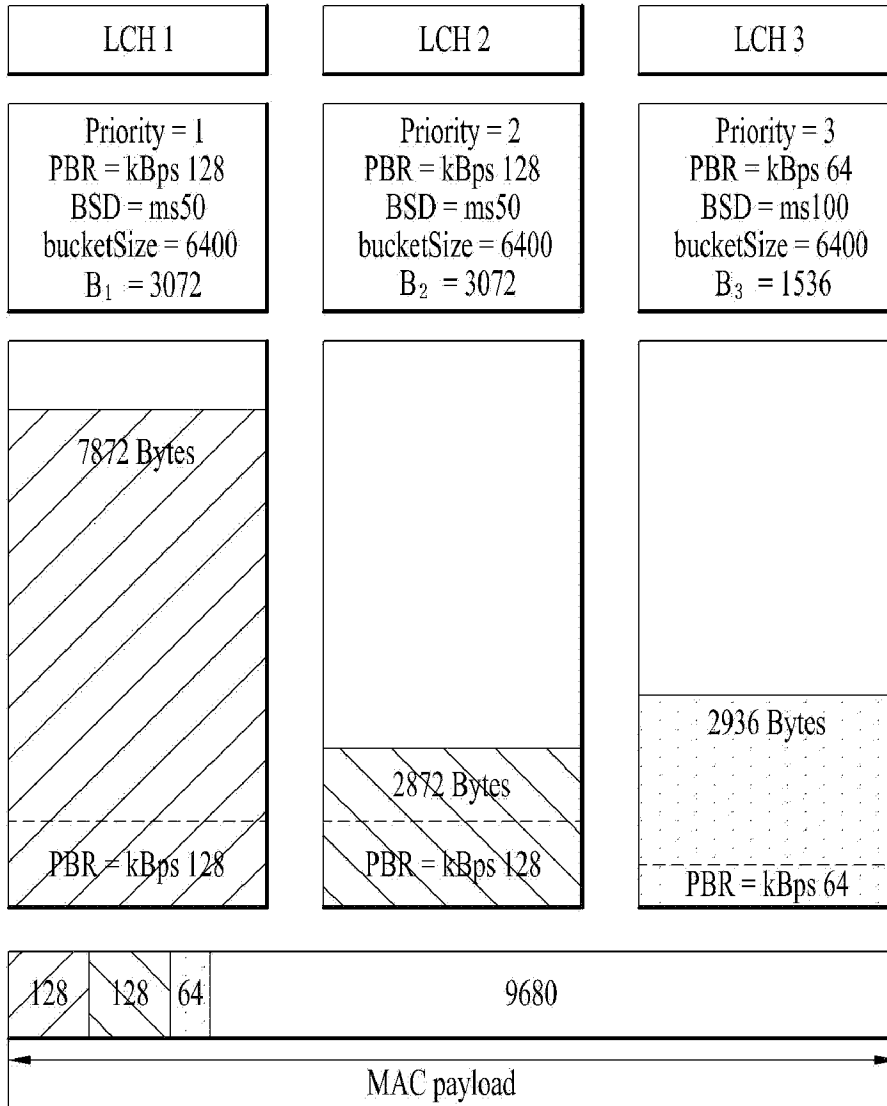

[Fig. 12]

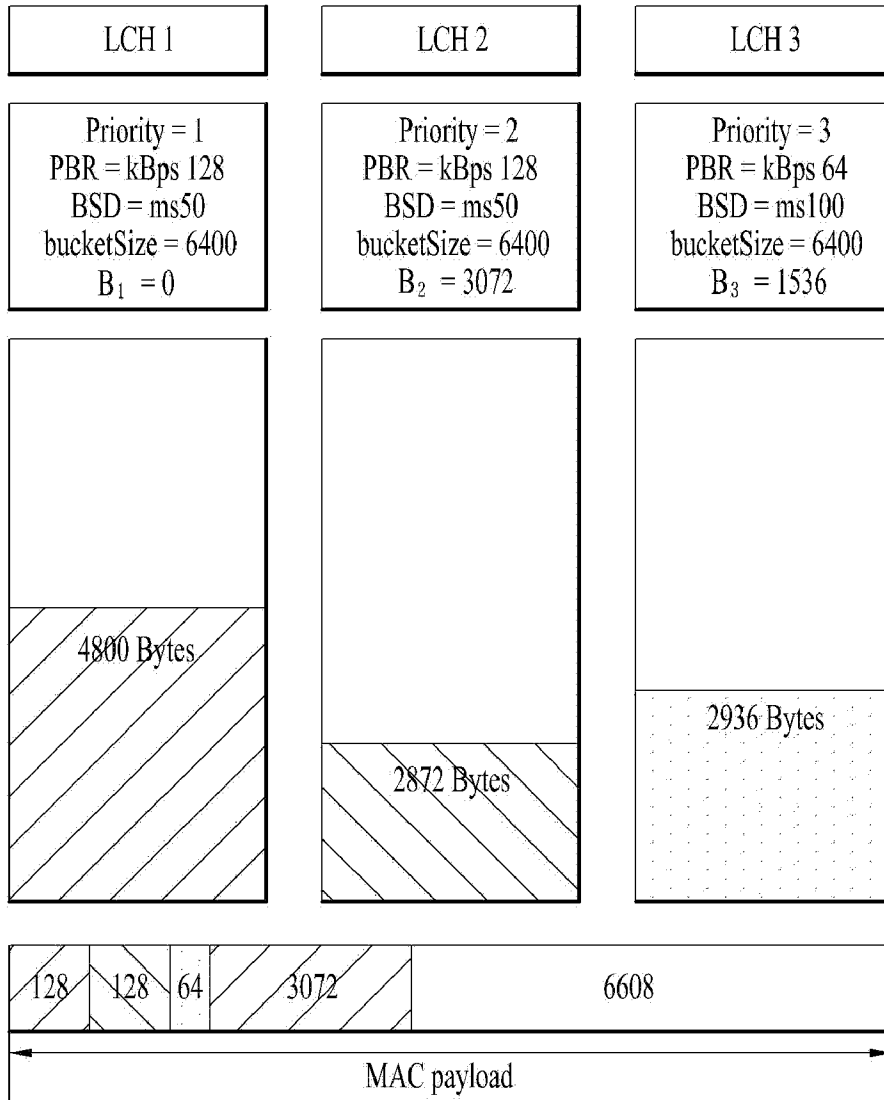

[Fig. 13]

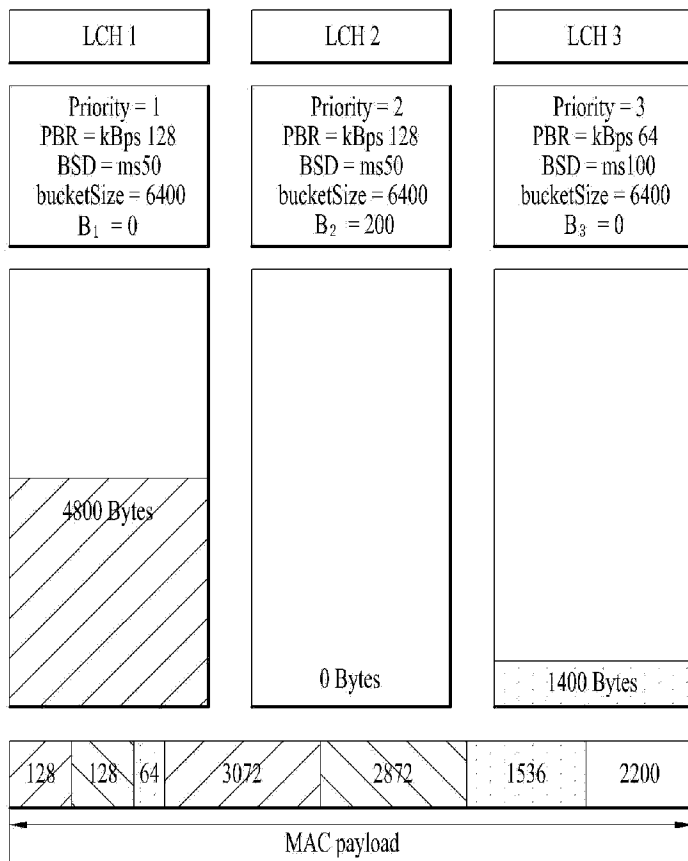

[Fig. 14]

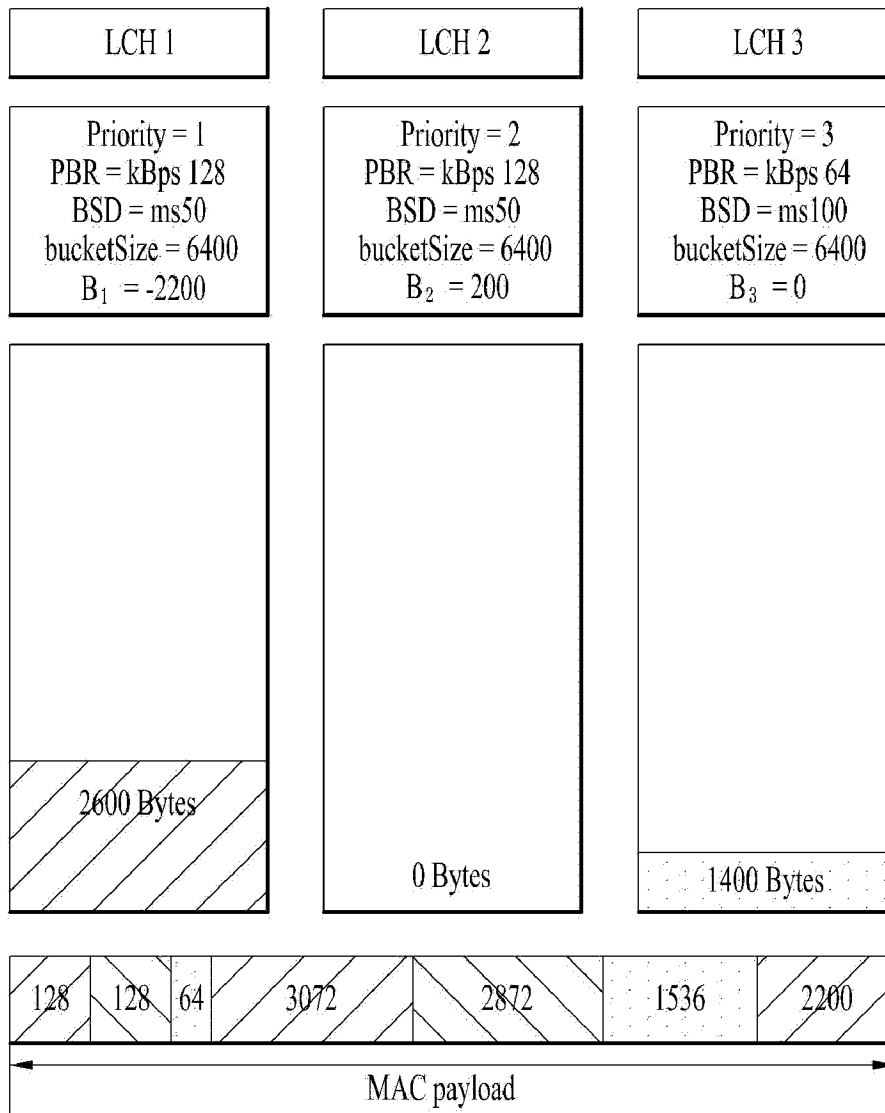

[Fig. 15]

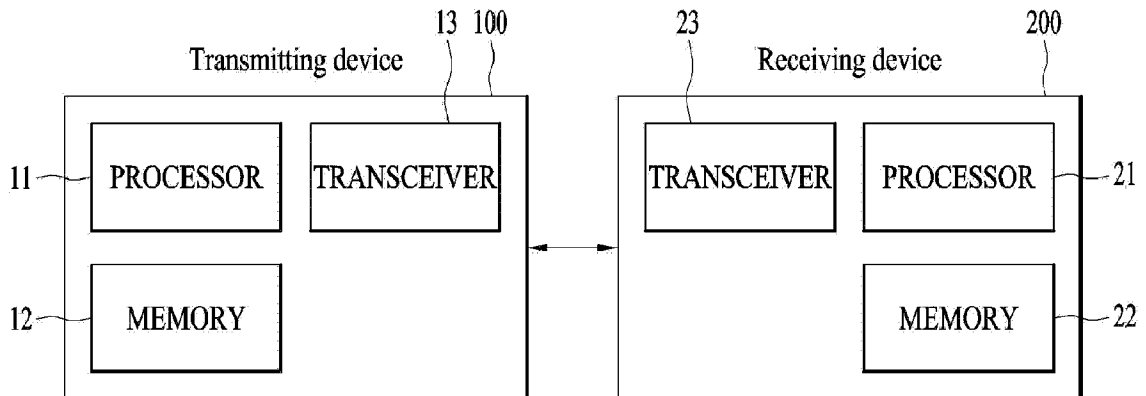

INTERNATIONAL SEARCH REPORT

International application No.
PCT/KR2019/007349**A. CLASSIFICATION OF SUBJECT MATTER****H04W 72/10(2009.01)i, H04W 72/04(2009.01)i, H04W 28/02(2009.01)i**

According to International Patent Classification (IPC) or to both national classification and IPC

B. FIELDS SEARCHEDMinimum documentation searched (classification system followed by classification symbols)
H04W 72/10; H04L 5/00; H04W 52/04; H04W 72/04; H04W 28/02Documentation searched other than minimum documentation to the extent that such documents are included in the fields searched
Korean utility models and applications for utility models
Japanese utility models and applications for utility modelsElectronic data base consulted during the international search (name of data base and, where practicable, search terms used)
eKOMPASS(KIPO internal) & keywords: uplink grant, logical channels, data unit, allocate, positive token value, prioritized bit rate (PBR), decrement, remaining resource, exhaust, priority, amount, ADAS**C. DOCUMENTS CONSIDERED TO BE RELEVANT**

Category*	Citation of document, with indication, where appropriate, of the relevant passages	Relevant to claim No.
A	US 2012-0057547 A1 (JOACHIM LOHR et al.) 8 March 2012 See paragraphs [0273]-[0304]; and figures 12-13.	1-11
A	3GPP TS 38.321 v15.1.0, '3GPP; TSGRAN; NR; MAC protocol specification (Release 15)', 2 April 2018 See section 5.4.3.1.3.	1-11
A	INTERDIGITAL INC., 'Details of the Logical Channel Prioritization Procedure for NR', R2-1704911, 3GPP TSG-RAN WG2 #98, Hangzhou, P.R. China, 6 May 2017 See section 2.	1-11
A	US 2017-0208606 A1 (SANECHIPS TECHNOLOGY CO., LTD.) 20 July 2017 See paragraphs [0054]-[0079]; and claims 1-6.	1-11
A	SAMSUNG ELECTRONICS CO., LTD., 'Study on V2X Media Handling and Interaction', S4-170730, 3GPP WG-SAA Meeting #94, Sophia Antipolis, France, 30 June 2017 See section 3.	1-11

 Further documents are listed in the continuation of Box C. See patent family annex.

* Special categories of cited documents:

"A" document defining the general state of the art which is not considered to be of particular relevance

"D" document cited by the applicant in the international application

"E" earlier application or patent but published on or after the international filing date

"L" document which may throw doubts on priority claim(s) or which is cited to establish the publication date of another citation or other special reason (as specified)

"O" document referring to an oral disclosure, use, exhibition or other means

"P" document published prior to the international filing date but later than the priority date claimed

"T" later document published after the international filing date or priority date and not in conflict with the application but cited to understand the principle or theory underlying the invention

"X" document of particular relevance; the claimed invention cannot be considered novel or cannot be considered to involve an inventive step when the document is taken alone

"Y" document of particular relevance; the claimed invention cannot be considered to involve an inventive step when the document is combined with one or more other such documents, such combination being obvious to a person skilled in the art

"&" document member of the same patent family

Date of the actual completion of the international search

24 September 2019 (24.09.2019)

Date of mailing of the international search report

24 September 2019 (24.09.2019)

Name and mailing address of the ISA/KR

International Application Division

Korean Intellectual Property Office

189 Cheongsa-ro, Seo-gu, Daejeon, 35208, Republic of Korea

Facsimile No. +82-42-481-8578

Authorized officer

YANG, Jeong Rok

Telephone No. +82-42-481-5709



INTERNATIONAL SEARCH REPORT

Information on patent family members

International application No.

PCT/KR2019/007349

Patent document cited in search report	Publication date	Patent family member(s)	Publication date
US 2012-0057547 A1	08/03/2012	CA 2793703 A1	06/10/2011
		CN 102415187 A	11/04/2012
		CN 102415187 B	02/07/2014
		CN 102918896 A	06/02/2013
		CN 102918896 B	14/09/2016
		CN 106851808 A	13/06/2017
		DK 2760241 T3	10/09/2018
		EP 2244514 A1	27/10/2010
		EP 2244515 A1	27/10/2010
		EP 2422564 A1	29/02/2012
		EP 2422564 B1	24/07/2013
		EP 2553986 A1	06/02/2013
		EP 2553986 B1	07/09/2016
		EP 2645800 A1	02/10/2013
		EP 2645800 B1	19/10/2016
		EP 2760241 A1	30/07/2014
		EP 2760241 B1	30/05/2018
		EP 3358890 A1	08/08/2018
		ES 2605682 T3	15/03/2017
		ES 2685572 T3	10/10/2018
		HR P20181395 T1	19/10/2018
		HU E039712 T2	28/02/2019
		JP 2012-525030 A	18/10/2012
		JP 2013-529403 A	18/07/2013
		JP 2015-008532 A	15/01/2015
		JP 2016-028475 A	25/02/2016
		JP 2017-050871 A	09/03/2017
		JP 2017-201794 A	09/11/2017
		JP 2019-041391 A	14/03/2019
		JP 5456155 B2	26/03/2014
		JP 5620569 B2	05/11/2014
		JP 5802816 B2	04/11/2015
		JP 6024935 B2	16/11/2016
		JP 6252957 B2	27/12/2017
		JP 6418510 B2	07/11/2018
		KR 10-1790593 B1	26/10/2017
		KR 10-1874276 B1	04/07/2018
		KR 10-1972288 B1	24/04/2019
		KR 10-2013-0024895 A	08/03/2013
		KR 10-2017-0120207 A	30/10/2017
		KR 10-2018-0072869 A	29/06/2018
		LT 2760241 T	10/09/2018
		MY 160765 A	15/03/2017
		PL 2760241 T3	31/12/2018
		RS 57612 B1	30/11/2018
		RU 2012141318 A	10/05/2014
		RU 2559201 C2	10/08/2015
		SI 2760241 T1	30/10/2018
		US 10117193 B2	30/10/2018

INTERNATIONAL SEARCH REPORT

Information on patent family members

International application No.

PCT/KR2019/007349

Patent document cited in search report	Publication date	Patent family member(s)	Publication date
		US 10349361 B2	09/07/2019
		US 2013-0058315 A1	07/03/2013
		US 2014-0161108 A1	12/06/2014
		US 2015-0189675 A1	02/07/2015
		US 2016-0353393 A1	01/12/2016
		US 2019-0028980 A1	24/01/2019
		US 2019-0253983 A1	15/08/2019
		US 8687541 B2	01/04/2014
		US 9008050 B2	14/04/2015
		US 9439217 B2	06/09/2016
		WO 2010-121708 A1	28/10/2010
		WO 2011-120716 A1	06/10/2011
US 2017-0208606 A1	20/07/2017	CN 105262572 A	20/01/2016
		WO 2015-117453 A1	13/08/2015