

**(12) PATENT**  
**(19) AUSTRALIAN PATENT OFFICE**

**(11) Application No. AU 199965369 B2**  
**(10) Patent No. 731997**

(54) Title  
**Highway crash cushion and components thereof**

(51)<sup>7</sup> International Patent Classification(s)  
**E01F 015/14**

(21) Application No: **199965369**

(22) Application Date: **1999.12.21**

(43) Publication Date : **2000.02.24**

(43) Publication Journal Date : **2000.02.24**

(44) Accepted Journal Date : **2001.04.12**

(62) Divisional of:  
**199670563**

(71) Applicant(s)  
**Energy Absorption Systems, Inc.**

(72) Inventor(s)  
**Michael H. Oberth; David C. Gertz; John V. Machado; Barry D. Stephens**

(74) Agent/Attorney  
**SPRUSON and FERGUSON,GPO Box 3898,SYDNEY NSW 2001**

(56) Related Art  
**EP 286782**  
**US 4321989**  
**EP 389081**

# HIGHWAY CRASH CUSHION AND COMPONENTS THEREOF

## ABSTRACT

A highway crash cushion (10) includes a single, central, rigid, guide rail (12) that guides the crash cushion (10) in axial collapse. Diaphragm assemblies (14) are each provided with recessed legs (58) and a central guide (74) that slides along the rail (12) while locking against the rail (12) in a lateral collision. The diaphragm assemblies (14) support fender panels (16) that include four longitudinally extending ridges (82), a central slot (84), and a tapered trailing edge (96) that reduces vehicle snagging. Energy absorbing elements (22) are disposed between the diaphragm assemblies (14), and each includes an indicator (122) that clearly indicates when the element (22) has been compressed and possibly damaged.

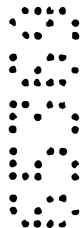

AUSTRALIA

PATENTS ACT 1990

**COMPLETE SPECIFICATION**

FOR A STANDARD PATENT

**ORIGINAL**

Name and  
Address  
of Applicant :

Energy Absorption Systems, Inc.  
One East Wacker Drive  
Chicago Illinois 60601  
United States of America

Actual  
Inventor(s):

Michael H Oberth, David C Gertz, John V Machado and  
Barry D Stephens

Address for  
Service:

Spruson & Ferguson  
St Martins Tower  
31 Market Street  
Sydney NSW 2000

Invention Title:

Highway Crash Cushion and Components Thereof

The following statement is a full description of this invention, including the best method of performing it known to me/us:-

# HIGHWAY CRASH CUSHION AND COMPONENTS THEREOF

5

- 1 -

## BACKGROUND OF THE INVENTION

10           The present invention relates to improvements to a highway crash cushion of the type having an array of diaphragms, a plurality of energy absorbing elements disposed between the diaphragms, and an array of fender panels extending alongside the diaphragms.

15           Highway crash cushions of this general type have proven to be successful in a wide variety of applications. Walker U.S. Patent 3,982,734 describes one early version of such a crash cushion, and Meinzer U.S. Patent 4,321,989 discloses another. Typically,  
20 such crash cushions are used alongside highways in front of obstructions such as concrete walls, toll booths and the like.

          In the event of an axial impact, the crash cushion is designed to absorb the kinetic energy of an  
25 impacting vehicle as the crash cushion collapses axially. In such an axial collapse, the diaphragms move closer to one another, the fender panels telescope over one another, and the energy absorbing elements are compressed. After such a collision many of the  
30 component parts can be reused by repositioning the diaphragms and fender panels in the original position, and replacing the energy absorbing elements and other damaged components.

          The performance of such a highway crash  
35 cushion in lateral rather than axial impacts is also significant. When an impacting vehicle strikes the fender panels obliquely, it is desirable that the crash cushion act as a guard rail, which redirects the impacting vehicle without sending it back into traffic  
40 at a steep angle, and without allowing the impacting

vehicle to move into the region on the other side of the crash cushion protected by the crash cushion.

Another aspect of such crash cushions is the need for simple maintenance and repair. Typically, such crash cushions are positioned alongside a high speed roadway, and it is therefore important to minimise traffic disruption and to minimise exposure of maintenance personnel to the hazards of adjacent traffic in maintenance and repair procedures.

In view of the foregoing operational and maintenance requirements for crash cushions, there is a need for an improved crash cushion that provides increased rigidity in a lateral impact, that decelerates an impacting vehicle in a more controlled manner in a lateral impact, both when the vehicle is moving along the fender panels in a forward and in a reverse direction, and to provide a crash cushion which is simpler to install and easier to maintain.

It is an object of the present invention to overcome or ameliorate some of the disadvantages of the prior art, or at least to provide a useful alternative.

#### Summary of the Invention

In a highway crash cushion of the type comprising a diaphragm and at least one energy absorbing element disposed adjacent the diaphragm and aligned along a longitudinal axis of the crash cushion such that in an axial collapse the diaphragm transfers compressive forces to the energy absorbing element, the crash cushion comprising:

a support structure disposed under the crash cushion and comprising a first end and a second end, the support structure being anchored to a support surface between the first and second ends;

a guide coupled to the diaphragm;  
the guide mounted to slide along the support structure and to restrict movement of the diaphragm with respect to the support structure in at least one lateral direction;

the diaphragm coupled to a leg assembly extending beneath the diaphragm on at least one side outboard of the support structure to support the diaphragm on the support surface.

There is further herein disclosed a highway crash cushion of the type comprising an array of diaphragms, a plurality of energy absorbing elements disposed between the diaphragms, and an array of fender panels extending alongside the diaphragms, including:



a single rail disposed under the crash cushion and anchored to a support surface;

a plurality of guides, each coupled to a respective one of the diaphragms and substantially centered with respect to the respective diaphragm;

5 said guides mounted on the rail to slide along the rail and to restrict movement of the respective diaphragms with respect to the rail in both lateral directions;

said rail substantially centered with respect to the respective diaphragms;

at least some of the diaphragms each coupled to a respective leg assembly extending beneath the respective diaphragm on both sides of the rail to support the  
10 diaphragm on a support surface.

The present invention, in a preferred embodiment can provide a highway crash cushion as described above including an improved diaphragm assembly. Each diaphragm assembly includes an upper part that comprises a diaphragm adapted to apply compressive loads to an adjacent energy absorbing element, and a lower part secured to  
15 the upper part. The lower part comprises a leg assembly comprising an upper portion mounted to support the upper part, a lower portion, two side portions and a centerline extending between the side portions. Each lower portion is connected to two feet shaped to support the leg assembly on a support surface. The feet extend outwardly from the respective leg assembly, away from the centerline, such that the feet are separated from  
20 the respective centerline by a distance  $D_F$ , the side portions are separated from the respective centerline by a distance  $D_L$ , and the ratio  $D_F/D_L$  is greater than 1.1. Alternately, the difference  $D_F - D_L$  can be maintained greater than 4 cm. By recessing the legs with respect to the feet, there is a reduced chance that an impacting vehicle will snag on the legs in a lateral impact. In this way, any tendency for the impacting vehicle to be  
25 decelerated in an uncontrolled manner is reduced.

Preferably, each leg assembly supports a removable guide on the centerline.

It should be noted that legs are required on both sides of the support structure only if the crash barrier is intended to be rigid against side impacts on both sides of the barrier. There are for example applications where a crash barrier is positioned alongside a  
30 roadway, and it only requires adequate structure to prevent the crash barrier from tilting away from the roadway in response to a side impact. In such a case only legs on the side of the support structure opposite the roadway are required (to prevent the crash barrier from tilting away from the roadway. This guide includes a first pair of spaced plates facing the centerline on one side of the centerline, and a second pair of spaced plates facing the centerline on the other side of the



centerline. This guide cooperates with the guide rail described above to provide rigidity in the crash cushion in a lateral impact.

5 The present invention also preferably provides a fender panel for a highway crash cushion as described above including a trailing edge, a leading

10 edge, and a side edge. The trailing edge is tapered such that the first and second portions of the trailing edge are separated from a reference line transverse to the side edge by lengths  $L_1$  and  $L_2$ , respectively. The length  $L_1$  is greater than the length  $L_2$  by at least 10 cm. Preferably, the fender panel defines a plurality of ridges extending generally parallel to the side edge, and the first portion of the trailing edge is positioned  
15 in a groove of the fender panel between adjacent ones of the ridges. The tapered trailing edge has been found to reduce the tendency of an impacting vehicle to snag on the fender panel when the impacting vehicle approaches the fender panel from the direction of the trailing  
20 edge.

The present invention, also preferably provides a fender panel for a highway crash cushion as described above comprising four parallel ridges separated

25 by three parallel grooves. The grooves comprise a central groove and two lateral grooves. The central groove forms a slot extending parallel to the ridges, and the slot extends over a length of at least one half the length of the fender panel. The grooves each have a respective width transverse to the slot, and the central  
30 groove width is greater than each of the lateral groove widths. In use, a fastener passes through the slot and is secured to the crash cushion to allow the fender panel to slide relative to the fastener. This arrangement has been found to provide increased strength  
35 to the fender panel with respect to bending, flattening

out, and tear-out, and increased pull-out resistance to the fastener.

The present invention, may also provide a highway crash cushion energy absorbing

5 element provided with an indicator movably mounted on the energy absorbing element to move between first and second positions. This indicator is visible outside of the energy absorbing element in at least the second position. A retainer is coupled to the energy absorbing  
10 element to retain the indicator in the first position prior to distortion of the energy absorbing element. The retainer is positioned and configured such that distortion of the energy absorbing element by more than a selected amount releases the indicator from the  
15 retainer. In the preferred embodiment described below, a spring is coupled to the indicator to bias the indicator to the second position, and the energy absorbing element includes a housing that forms a zone of increased compressibility in the region between the  
20 mounting location for the indicator and the mounting location for the retainer.

In use, a maintenance inspector can readily determine remotely whether an individual energy absorbing element has been deformed (as for example in a  
25 low speed collision). Such deformation releases the indicator from the retainer and allows the indicator to move to the second position, where it can readily be seen.

The invention itself, together with further  
30 objects and advantages, will best be understood by reference to the following detailed description, taken in conjunction with the accompanying drawings.

### BRIEF DESCRIPTION OF THE DRAWINGS

Figure 1 is a perspective view of a highway crash cushion;

Figure 2 is a top view of a segment of the guide rail of the embodiment of Figure  
5 1;

Figure 3 is a side elevational view taken along line 3-3 of Figure 2;

Figure 4 is an end view taken along line 4-4 of Figure 2;

Figure 5 is an end perspective view of the guide rail segment of Figure 2;

Figure 6 is a front elevational view of a diaphragm assembly included in the  
10 embodiment of Figure 1, showing the relationship between the diaphragm assembly and  
the guide rail;

Figure 7 is a side view of the diaphragm assembly of Figure 6;

Figure 8 is a cross-sectional view of one of the fender panels of the embodiment  
of Figure 1;

Figure 9 is a plan view of a metal plate from which the fender panel of Figure 8  
15 is formed;

Figure 10 is an exploded perspective view of one of the energy absorbing  
elements of the embodiment of Figure 1;

Figure 11 is a perspective view showing the indicator of Figure 10 in a raised  
20 position; and

Figure 12 is a cross sectional view taken along line 12-12 of Figure 11.

### DETAILED DESCRIPTION OF THE PREFERRED EMBODIMENTS

25 Turning now to the drawings, Figure 1 shows a perspective view of a highway  
crash cushion 10. The crash cushion 10 is mounted to slide

axially along a guide rail 12. The crash cushion 10 includes an array of spaced, parallel diaphragm assemblies 14. Fender panels 16 are secured between adjacent diaphragm assemblies 14, and the fender panels 5 16 and the diaphragm assemblies 14 form an array of enclosed bays. An energy absorbing element 22 is disposed within each of the bays, between an adjacent pair of diaphragm assemblies 14. A nose fender 24 extends around the forwardmost energy absorbing element 10 22.

The following discussion will take up each of the major components of the crash cushion 10.

#### The Guide Rail

15 Figures 2-5 show various views of a portion of the guide rail 12. In this embodiment, the guide rail 12 is made up of two or more segments 26. Each of the segments 26 includes an upper plate 28 and two side plates 30. The upper plate 28 forms two opposed, 20 horizontally extending flanges 29. The side plates 30 are secured to a series of lower plates 32. Each of the lower plates 32 defines at least two openings 34 sized to receive a respective ground anchor (not shown in Figures 2-5). Bracing plates 36 are secured between 25 the side plates 30 and the lower plates 32 to provide additional rigidity.

As shown in Figure 4, one end of the segment 26 defines a central recess 38 which in this embodiment is generally rectangular in shape. As shown in Figures 30 2, 3, and 5, the other end of the segment 26 defines a central protrusion 40. The central protrusion 40 is generally rectangular in shape, but it defines a sloping lower surface 42. In this embodiment the central protrusion 40 is welded in position in the 35 rearward end of the segment 26.

Depending upon the application, the crash cushion 10 can have a varying number of diaphragm assemblies 14. In the example shown in Figure 1, there are five separate diaphragm assemblies 14, and the 5 guide rail 12 is made up of two segments 26. The central protrusion 40 of the forward segment fits into the central recess 38 of the rearward segment to maintain alignment of the two segments 26.

Simply by way of example, and without 10 intending any limitation, the following exemplary dimensions have been found suitable. The upper plate 28 can be formed of steel plate 10 cm in width and 1.3 cm in thickness. The side plates 30 can be formed of flat bar 7.6 cm in height and .95 cm in thickness. The 15 lower plates 32 can be 1.3 cm in thickness. A hot rolled steel such as ASTM A-36 or AISI 1020 has been found suitable, and standard welding techniques are used to secure the various components together.

The segments 26 are shorter and therefore 20 more easily transported and installed than a one-piece guide rail. Furthermore, in the event of damage, only the damaged segment 26 must be replaced, and maintenance costs are thereby reduced. The sloping lower surface 42 of the central protrusion 40 and the 25 slots in the lower plate 32 near the central protrusion 40 allow the damaged segment 26 to be removed by lifting up the end forming the central recess 38.

By providing three separate segments, having 30 lengths appropriate for one bay, two bays, and three bays, respectively, crash cushions of varying lengths between one bay and twelve bays can readily be assembled.

#### The Diaphragm Assemblies

35 Figures 6 and 7 show front and side views, respectively, of a diaphragm assembly 14. Each

diaphragm assembly 14 includes an upper part 44 and a lower part 46. The upper part 44 forms a diaphragm, and includes a central panel 48, which in this embodiment is a ridged metal plate, identical in cross section to the fender panels described below. The panel 48 is rigidly secured at each end to a respective metal plate 50. Support brackets 52 can be secured to the lower edge of the panel 48 to support the energy absorbing elements. Alignment brackets 54 can be secured to the panel 48 to locate the energy absorbing elements laterally in the bay.

The lower part 46 of the diaphragm assembly 14 includes a leg assembly 56. The leg assembly 56 in this embodiment includes two rectangular-section legs 58 which are rigidly secured to the upper portion 44, as for example by welding. The leg assembly 56 forms an upper portion 60 that is secured to the diaphragm of the diaphragm assembly 14, two side portions 62, and a lower portion 64. The side portions 62 are symmetrically positioned with respect to a centerline 66 that is vertically oriented in this embodiment.

Each of the legs 58 supports a respective foot 68. The feet 68 extend downwardly and outwardly from the lower portion 64 of the legs 58. Each of the feet 68 terminates in a lower plate 70 and a pair of side plates 72. The lower plate 70 is shaped to support the diaphragm assembly 14 on a support surface S, and to slide freely along the support surface S. This support surface S can be formed for example by a concrete pad. The side plates 72 form ramps extending upwardly from the lower plate 72 to the foot 68. These ramps reduce snagging of the tire or wheel of an impacting vehicle on the lowermost portion of the foot 68.

In Figure 6 the reference symbol  $D_f$  is used to designate the distance of the outermost edge of the

foot from the centerline and reference symbol  $D_L$  is used to designate the distance of the outermost portion of the side portion 62 from the centerline 66.

As shown in Figure 6 and 7, the legs 58 are recessed with respect both to the feet 68 and the panel 48. This way, any tendency of the wheel or tire of a vehicle moving along the fender panels to snag on the legs 58 is substantially reduced. The ratio  $D_F/D_L$  is greater than 1.1, preferably greater than 1.4, and most preferably greater than 1.8. In this way, the legs 58 are substantially recessed. Similarly, the difference between  $D_F/D_L$  is greater than 4 cm, preferably greater than 8 cm, and most preferably greater than 12 cm to obtain this advantage. In this preferred embodiment the ratio  $D_F/D_L$  is 1.85 and the difference  $D_F-D_L$  is 14.8 cm.

As shown in Figure 6, two guides 74 are removably secured between the legs 58, as for example by fasteners 76. Each of the guides 74 includes a respective pair of spaced, horizontal plates 78, 80 facing the centerline 66. The plates 78, 80 receive the flanges 29 therebetween, with the upper plates 78 resting on the upper surface of the flanges 29 and the lower plates 80 positioned to engage the lower surface of the flanges 29.

During operation, the weight of the diaphragm assemblies 14 is supported by the feet 68 and the plates 78. The plates 80 prevent the diaphragm assemblies 14 from moving upwardly with respect to the guide rail 12 in an impact.

Because the guides 74 are held in place in the diaphragm assembly 14 by removable fasteners 76, the guides 74 can be replaced if damaged in an impact, without removing the diaphragm assemblies 14.

As the crash cushion 10 collapses in an axial impact, the diaphragm assemblies 14 slide down the guide rail 12, while the guide rail 12 prevents substantially

all lateral movement of the crash cushion 10.

Preferably, the guides 74 have a substantial length, and can for example be 20 cm in length and approximately 1.3 cm in thickness. A hot rolled steel such as ASTM-36 or  
5 AISM 1020 has been found suitable. The length of the guides 74 reduces any tendency of the diaphragm assemblies 14 to rock and bind to the guide rail 12 in an axial collapse, thereby insuring a stable, consistent axial collapse of the crash cushion. Because the lower  
10 plates 80 engage the underside of the flanges 29, overturning of the crash cushion 10 is prevented. The upper plates 78 of the guides 74 maintain the diaphragm assemblies 14 at the proper height relative to the guide rail 12, in spite of irregularities in the support  
15 surface S. The guide rail 12 and the guide 74 provide lateral restraint, guided collapse, and resistance to overturning throughout the entire axial stroke of the collapsing crash cushion 10.

Furthermore, in the event of a side impact  
20 against the fender panels 16, the guides 74 tend to lock against the guide rail 12 as they are moved by the impacting vehicle into a position oblique to the guide rail 12. This locking action provides further lateral rigidity to the crash cushion 10 in a lateral impact.

25 The wide separation between the feet 68 increases stability of the crash cushion 10 and resistance to overturning in a lateral impact.

#### The Fender Panels

30 Turning now to Figures 8 and 9, the fender panels 16 have been improved to provide increased rigidity and improved operation to the crash cushion 10. Figure 8 is a cross-sectional view through one of the fender panels 16. As shown in Figure 8, the fender  
35 panel 16 includes four parallel ridges 82 and three parallel grooves. These grooves are not identical to

one another, and the central groove 84 is in this embodiment wider than the lateral grooves 86. The grooves 84, 86 define lower-most portions that are coplanar, and the ridges 82 are uniform in height.

5                   Because the fender panel 16 includes four ridges 82 instead of the conventional three, it is symmetrical about the central groove 84. This allows the longitudinally extending slot 88 to be positioned on the flat portion of the central groove 84. It has been  
10 discovered that for a fender panel of the same height, material and thickness as in a prior art thrie beam, the improved geometry discussed above increases the section modulus and the tensile strength of the panel, by approximately 20% for the section modulus, and  
15 approximately 15% for the tensile cross section. Furthermore, by having three grooves rather than two as in the prior art thrie panel, an additional fastener can be used to secure the fender panel 16 to the adjacent diaphragm assembly 14, thereby increasing tear out  
20 strength by 50%.

                  Simply by way of example, preferred dimensions for the fender panel 16 are listed in the attached Table 1. In this embodiment, the fender panel can be formed of a 10 gauge, cold rolled steel such as  
25 that identified as alloy ASTM-A-570, grade 50. This material has a yield strength of 50,000 psi.

Reference Symbol from Figure 8	Dimension (mm unless otherwise indicated)
a	109
b	145
c	83
d	42
e	80
f	43
g	128
h	166
I	44°
R <sub>1</sub>	15
R <sub>2</sub>	6

Figure 9 shows a fender panel metal plate 90 in plan view, prior to formation of the ridges 82 and grooves 84, 86. This metal plate 90 defines a longitudinal slot 88 and three attachment apertures 92. The metal plate defines a leading edge 94, a trailing edge 96 and two side edges 98. In the following discussion the leading edge 94 will be considered to define a reference line that is perpendicular to the side edges 98. In alternate embodiments it is not required that the leading edge 94 be shaped in this manner. The apertures 92 are used to fasten the fender panel to a forward diaphragm assembly 14, and the slot 88 is used to fasten the fender panel to a rearward diaphragm assembly 14. The slot 88 extends over more than one-half the length of the plate 90.

As shown in Figure 9, the trailing edge 96 is tapered, and it includes a first portion 100 and a second portion 102. In this embodiment the trailing edge 96 is symmetrical, and the first portion 100 is aligned with the slot 88, while the second portion 102 is formed in two parts, one adjacent each of the side edges 98. The symbol  $L_1$  is used for the separation between the first portion 100 and the leading edge 94, and the symbol  $L_2$  is used for the separation between the second portion 102 and the leading edge 94. In this embodiment the difference  $L_1$  minus  $L_2$  is greater than or equal to 10 cm. Preferably this difference is greater than 20 cm, and most preferably it is greater than 30 cm. In this embodiment  $L_1$  equals 131 cm,  $L_2$  equals 98 cm and  $L_1 - L_2$  equals 33 cm. The slot 88 can be 85 cm in length. As shown in Figure 1, the first portion 100 of a given fender panel 16 is disposed in the central groove 84 of the fender panel 16 that is adjacent to the rear.

It has been discovered that this arrangement reduces vehicle snagging in a wrong-way impact, where the impacting vehicle slides along the side of the crash cushion 10, approaching the fender panels 16 such that the trailing edges 96 make initial fender panel contact with the vehicle (from left to right with respect to the side of the crash cushion 10 shown in Figure 1). Because the first portions 100 are disposed in the central grooves 84, they are somewhat recessed and less likely to snag the vehicle. The trailing edge 96 is tapered, sloping upwardly on the upper portion of the trailing edge and downwardly on the lower portion of the trailing edge. This tapered arrangement for the trailing edge has been found to reduce vehicle snagging. When the vehicle sheet metal begins to tear as it slides longitudinally down one side of the crash cushion 10, the vehicle sheet metal encounters an upward or downwardly sloping portion of the trailing edge 96. This causes the tearing action to cease. Snagging of the vehicle tends to be self-releasing, and not to become progressively worse as the vehicle proceeds down the crash cushion 10 in a wrong-way impact.

Though the trailing edge 96 discussed above is symmetrical about the centerline of the fender panel 16, this is not required in all embodiments. If desired, various asymmetrical arrangements can be used. Also, if desired the fender panel can define multiple first portions, each disposed in a respective groove, and each separated by a substantially constant distance from the reference line.

As shown in Figure 1, the rearward portion of the fender panel 16 is secured to the rearward adjacent diaphragm by a fastener 104 includes a plate 106. This plate 106 has sides shaped to conform to the adjacent ridges 82, and forward and rearward edges that are bevelled to reduce vehicle snagging. The plate 106 is

relatively large, and can for example be 25 cm in length, and can define a lug extending downwardly into the respective slot 88. This arrangement provides a system in which the fender panels telescope smoothly against one another in an axial collapse, and in which pull out of the fastener 104 is substantially prevented.

The improved geometry of the fender panel 16 is not restricted to use with highway crash cushions, but can be used with a variety of other roadside barriers, including guard rails. In some of these applications the slot 88 may not be required.

#### The Energy Absorbing Element

Figure 10 shows an exploded view of one of the energy absorbing elements 22. This energy absorbing element 22 includes an outer housing 108 that is formed in two parts that meet at a horizontally oriented seam 110. The housing defines front and rear surfaces 112, 114 that are positioned against the adjacent diaphragm assemblies 14. Each housing 108 also defines a respective top surface 116. The top surface 116 defines a zone of increased compressibility 118 that in this embodiment defines an array of parallel pleats or corrugations 120. These corrugations 120 extend generally parallel to the front and rear surfaces 112, 114. The zone of increased compressibility 118 ensures that in the event the housing 108 is compressed axially between the front and rear surfaces 112, 114, this compression is initially localized in the zone 118. Simply by way of example, the housing 108 can have a length, height and width of about 82, 57, and 55 cm, and the zone 118 can have a width of about 11 cm.

The housing 108 can be molded of any suitable material, such as linear, low-density polyethylene having an ultraviolet inhibitor for example. The housing 108 can contain any suitable energy absorbing

components 109, and this invention is not limited to any specific choice for these components 109. For example, the energy absorbing components can be formed as described in U.S. Patent 4,352,484, using a paper  
5 honeycomb material (5 cm cell diameter and 5 cm layer thickness) and a polyurethane foam. Alternately, the energy absorbing elements 109 can be formed as four metal honeycomb elements 111, each 17.8 cm thick, with a cell diameter of 3.8 cm. The elements are preferably  
10 formed of low carbon, fully annealed steel sheets (0.45 mm thick in one element and 0.71 mm thick in the other three). In the embodiment described here, the forward energy absorbing elements use the paper honeycomb material and the rearward energy absorbing elements use  
15 the steel material, both as described above. If desired, the brackets 52, 54 can be deleted and replaced with brackets (not shown) on the panels 48 that support the housing 108 at the lower, protruding edge of the upper part of the housing, adjacent the seam 110.

20           Figures 11 and 12 show two views of an indicator 122 that is mounted on the top surface 116 of the energy absorbing element. This indicator 22 includes a plate 124 that has an outer surface. This outer surface can for example be covered with a  
25 reflective material. The plate 124 is mounted for pivotal movement by a mounting 126 on a first side of the zone 118. The indicator 122 includes a lip 128 on the opposite end of the plate 124. A retainer 130 is mounted to the top surface 116 on the opposite side of  
30 the zone 118. As best shown in Figure 12, the indicator 122 is pivotally movable between a first position in which the plate 124 is alongside and recessed into the top surface 116, and a second position in which the plate 124 is pivoted upwardly and outwardly to a  
35 position substantially perpendicular to the top surface 116. The first and second positions can each correspond

to a range of positions. In the second position the plate 124 is clearly visible from outside the energy absorbing element 122. A spring 132 biases the indicator 122 to the second, more visible position.

5           As shown in Figure 12, the indicator 122 is initially installed in the first or lower position. In this position the retainer 130 overlaps the lip 128 by a selected distance, which can correspond to a range of distances. In this embodiment, the selected distance is  
10       about 1 to 2 cm. The indicator 122 is mounted to the housing 108 at a first location, and the retainer 130 is mounted to the housing at a second location.

          In the event that the housing 108 is distorted even temporarily in a low speed event such  
15       that the first and second locations approach one another by more than the selected distance of overlap between the lip 128 and the retainer 130, then the indicator 128 moves out of engagement with the retainer 130, and the spring 132 moves the indicator 122 to the upper position  
20       shown in Figure 11.

          A maintenance inspector can readily determine if any of the energy absorbing elements 22 has been compressed excessively simply by looking for indicators 122 in the extended position. This can be done at a  
25       considerable distance, and does not require close inspection.

          Of course, many alternatives to the indicator 122 are possible. For example, the spring does not have to be a separate element, and the desired biasing force  
30       can be obtained by bending of the indicator 122 itself. Furthermore, the zone of increased compressibility can be formed with many geometries, and corrugations are not always required. If desired, the retainer 130 can engage the indicator 122 along the side rather than the  
35       end of the indicator 122. Furthermore, the indicator

can move between the first and second positions with translational rather than pivoting movements.

Conclusion

5                   From the foregoing detailed description it should be apparent that an improved crash cushion has been described. The central guide rail reduces vehicle snagging and simplifies installation while providing excellent rigidity against lateral movement and  
10 controlled axial collapse. The improved diaphragm assembly utilizes recessed legs that again reduce vehicle snagging. These assemblies are rigid, and are designed to lock against the guide rail in a lateral impact. The improved fender panels are stronger, with  
15 an improved cross-sectional shape that increases pull out resistance and enhances a controlled axial collapse. The tapered trailing edge further reduces vehicle snagging in a wrong-way collision. The energy absorbing element indicator indicates remotely to a maintenance  
20 inspector that the element has been compressed and possibly damaged, and is therefore in need of replacement.

                  Of course, it should be understood that a wide range of changes and modifications can be made to  
25 the preferred embodiment described above. It is therefore intended that the foregoing detailed description be considered as illustrative and not as limiting. It is the following claims, including all equivalents, that are intended to define the scope of this invention.

30

**The claims defining the invention are as follows:-**

1. In a highway crash cushion of the type comprising a diaphragm and at least one energy absorbing element disposed adjacent the diaphragm and aligned along a longitudinal axis of the crash cushion such that in an axial collapse the diaphragm  
5 transfers compressive forces to the energy absorbing element, the crash cushion comprising:

a support structure disposed under the crash cushion and comprising a first end and a second end, the support structure being anchored to a support surface between the first and second ends;

10 a guide coupled to the diaphragm;  
the guide mounted to slide along the support structure and to restrict movement of the diaphragm with respect to the support structure in at least one lateral direction;

15 the diaphragm coupled to a leg assembly extending beneath the diaphragm on at least one side outboard of the support structure to support the diaphragm on the support surface.

2. The invention of claim 1 wherein the guide is mounted to slide along the support structure without extending below a lower surface of the support structure.

20 3. The invention of claim 1 wherein the guide is mounted to slide along the support structure and to allow contact between a lower surface of the support structure and the support surface.

4. The invention of claim 1 wherein the support structure is anchored to the support surface under the crash cushion.

25 5. The invention of claim 1 wherein the support structure is anchored to the support surface under the diaphragm or the at least one energy absorbing element.

6. The invention of claim 1 wherein the support structure is anchored to the support surface at a first location and wherein the diaphragm moves past the first location during collapse of the crash cushion.



7. The invention of Claim 1 wherein the support structure comprises a single rail.

8. The invention of Claim 1 wherein the support structure comprises a plurality of axially aligned, releasably interconnected support structure segments.

9. The invention of Claim 8 wherein at least one support structure segment forms a recess at one end, the recess adapted to receive a protrusion extending outwardly from an adjacent support structure segment.

10. The invention of Claim 9 wherein the protrusion extending outwardly from the adjacent support structure segment is formed in the adjacent support structure segment.

11. The invention of Claim 1 wherein the guide and the leg assembly provide resistance to overturning in the at least one lateral direction.

12. The invention of Claim 1 wherein the guide is mounted to restrict movement of the diaphragm with respect to the support structure in both lateral directions.

13. The invention of Claim 1 wherein the leg assembly extends beneath the diaphragm on both sides outboard of the support structure to support the diaphragm on the support surface.

14. The invention of Claim 1 wherein the support structure comprises first and second flanges, and wherein the guide extends under the flanges to prevent excessive upward movement of the diaphragm with respect to the support structure.

15. The invention of Claim 1 wherein the leg assembly extends on both sides of the support structure such that the leg assembly extends laterally outwardly of all of the guide and laterally outwardly of all of the support structure.



16. The invention of Claim 1 wherein the leg assembly comprises two legs, each leg extending on a respective side of the support structure such that the legs extend laterally farther from a centerline aligned with the support structure than both the guide and the support structure.

5 17. The invention of Claim 1 wherein the leg assembly comprises two legs arranged such that all of the support structure and the guide are disposed between the legs.

18. The invention of Claim 1 wherein at least a forward portion of the crash cushion is freestanding.

10 19. The invention of Claim 1 further comprising an additional diaphragm and an additional energy absorbing element disposed between the additional diaphragm and the first-mentioned diaphragm.

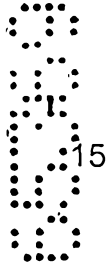

15 20. The invention of Claim 19 further comprising a fender panel extending alongside the additional diaphragm and the first-mentioned diaphragm.



20 21. The invention of Claim 19 further comprising an additional guide coupled to the additional diaphragm, wherein the additional guide is mounted to slide along the support structure and to restrict movement of the additional diaphragm with respect to the support structure in at least one lateral direction.

22. The invention of Claim 21 wherein the additional guide is mounted to restrict movement of the additional diaphragm with respect to the support structure in both lateral directions.

25 23. The invention of Claim 19 wherein the support structure is anchored to the support surface between the additional diaphragm and the first-mentioned diaphragm.

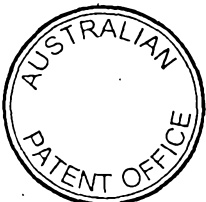

24. The invention of Claim 1 further comprising an additional diaphragm and an additional energy absorbing element disposed between the additional diaphragm and the first-mentioned diaphragm, wherein the additional diaphragm is coupled to an additional leg assembly extending  
 5 beneath the additional diaphragm on at least one side outboard of the support structure to support the additional diaphragm on the support surface.

25. The invention of Claim 1 further comprising an additional diaphragm and an additional energy absorbing element disposed between the additional diaphragm and the first-mentioned diaphragm, wherein the additional diaphragm is coupled to an additional leg assembly extending  
 10 beneath the additional diaphragm on both sides outboard of the support structure to support the additional diaphragm on the support surface.

26. The invention of Claim 1 further comprising:  
 an additional diaphragm;  
 an additional energy absorbing element disposed between the additional diaphragm and the first-mentioned diaphragm;  
 an additional leg assembly, the additional leg assembly and the first-mentioned leg assembly each comprising an upper portion mounted to a respective one of the additional diaphragm and the first-mentioned diaphragm, a lower portion, two side portions, and a centerline extending between the side portions;  
 each said lower portion connected to two feet shaped to support the respective leg assembly on the support surface;  
 the feet extending outwardly from the respective leg assembly, away from the centerline, such that the feet are separated from the respective centerline by a maximum distance  $D_F$ , the side portions are separated from the respective centerline by a maximum distance  $D_L$ , and the ratio  $D_F / D_L$  is greater than 1.1.

27. The invention of Claim 26 wherein the ratio  $D_F / D_L$  is greater than 1.4.



28. The invention of Claim 26 wherein the ratio  $D_F / D_L$  is greater than 1.8.

29. The invention of Claim 26 wherein each foot angles downwardly and outwardly from the respective leg assembly.

5 30. The invention of Claim 26 wherein each foot comprises a side plate adjacent a lower portion of the respective foot, each side plate extending outwardly and downwardly from the respective foot to create a ramp extending transversely to the respective one of the additional diaphragm and the first-mentioned diaphragm.

10 31. The invention of Claim 26 wherein the first-mentioned leg assembly comprises the guide and wherein the additional leg assembly comprises an additional guide, the guide and additional guide each centered on the centerline and comprising a first pair of spaced plates facing the centerline on one side of the centerline and a second pair of spaced plates facing the centerline on the other side of the centerline.

15 32. The invention of Claim 1 further comprising:  
an additional diaphragm;

an additional energy absorbing element disposed between the additional diaphragm and the first-mentioned diaphragm;

20 an additional leg assembly, the additional leg assembly and the first-mentioned leg assembly each comprising an upper portion mounted to a respective one of the additional diaphragm and the first-mentioned diaphragm, a lower portion, two side portions, and a centerline extending between the side portions;

25 each said lower portion connected to two feet shaped to support the respective leg assembly on the support surface;

the feet extending outwardly from the respective leg assembly, away from the centerline, such that the feet are separated from the respective centerline by a maximum distance  $D_F$ , the side portions are separated from

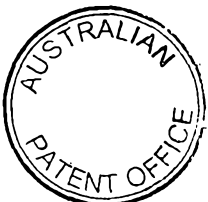

the respective centerline by a maximum distance  $D_L$ , and the difference  $D_F - D_L$  is greater than 4 cm.

33. The invention of Claim 32 wherein the difference  $D_F - D_L$  is greater than 8 cm.

5 34. The invention of Claim 32 wherein the difference  $D_F - D_L$  is greater than 12 cm.

35. The invention of Claim 32 wherein each foot angles downwardly and outwardly from the respective leg assembly.

10 36. The invention of Claim 32 wherein each foot comprises a side plate adjacent a lower portion of the respective foot, each side plate extending outwardly and downwardly from the respective foot to create a ramp extending transversely to the respective one of the additional diaphragm and the first-mentioned diaphragm.

15 37. The invention of Claim 32 wherein the first-mentioned leg assembly comprises the guide and wherein the additional leg assembly comprises an additional guide, the guide and additional guide each centered on the centerline and comprising a first pair of spaced plates facing the centerline on one side of the centerline and a second pair of spaced plates facing the centerline on the other side of the centerline.

20 38. The invention of Claim 1 wherein the support structure comprises at least three axially aligned, releasably interconnected support structure segments, wherein the support structure is anchored to the support surface near a first end of the support structure, near a second end of the support structure, and intermediate the first and second ends of the support structure.

25 39. The invention of Claim 1 wherein the guide is substantially centered with respect to the diaphragm.



40. The invention of Claim 1 wherein the support structure is substantially centered with respect to the diaphragm.

41. The invention of Claim 1 further comprising an additional element, the energy absorbing element being disposed between the diaphragm and the additional element.

42. The invention of Claim 41 further comprising a fender panel extending alongside the diaphragm and the additional element.

43. A highway crash cushion of the type comprising an array of diaphragms, a plurality of energy absorbing elements disposed between the diaphragms, and an array of fender panels extending alongside the diaphragms, including:

a single rail disposed under the crash cushion and anchored to a support surface;

a plurality of guides, each coupled to a respective one of the diaphragms and substantially centered with respect to the respective diaphragm;

said guides mounted on the rail to slide along the rail and to restrict movement of the respective diaphragms with respect to the rail in both lateral directions;

said rail substantially centered with respect to the respective diaphragms;

at least some of the diaphragms each coupled to a respective leg assembly extending beneath the respective diaphragm on both sides of the rail to support the diaphragm on a support surface.

44. The highway crash cushion of claim 43 wherein the rail comprises a plurality of interconnected rail segments, wherein each rail segment forms a central protrusion at one end and a central recess at the other end, and wherein the protrusion of one rail segment is received within the recess of an adjacent rail segment.

45. The highway crash cushion of claim 43 wherein the rail comprises first and second flanges, and the guides extend under the flanges to prevent excessive upward movement of the diaphragms with respect to the rail.

46. The highway crash cushion of claim 43 wherein each leg assembly comprises an upper portion mounted to a respective one of the diaphragms, a lower portion, two side portions, and a centerline extending between the side portions;

each said lower portion connected to two feet shaped to support the respective leg assembly on a support surface;

said feet extending outwardly from the respective leg assembly, away from the centerline, such that the feet are separated from the respective centerline by a maximum



distance  $D_F$ , the side portions, are separated from the respective centerline by a maximum distance  $D_L$ , and the ratio  $D_F/D_L$  is greater than 1.1.

47. The highway crash cushion of claim 46 wherein the ratio  $D_F/D_L$  is greater than 1.8.

5 48. The highway crash cushion of claim 46 wherein the difference  $D_F/D_L$  is greater than 4 cm.

49. The highway crash cushion of claim 48 wherein the difference  $D_F/D_L$  is greater than 12 cm.

10 50. The highway crash cushion of any one of claims 46 to 48 wherein each foot angles downwardly and outwardly from the respective leg assembly.

15 51. The highway crash cushion of any one of claims 46 to 48 wherein each leg assembly supports a respective one of the guides centered on the centerline, said guides each comprising a first pair of spaced plates facing the centerline on one side of the centerline and a second pair of spaced plates facing the centerline on the other side of the centerline.

52. The highway crash cushion of claim 43 wherein at least some of the fender panels comprise:

20 a metal plate comprising a leading edge, a trailing edge, and two spaced side edges extending between the leading and trailing edges, said plate defining a plurality of ridges extending generally parallel to at least one of the side edges;

said trailing edge tapered such that first and second portions of the trailing edge are separated from a reference line transverse to the side edge by lengths  $L_1$  and  $L_2$ , respectively, measured parallel to the side edge;

25 the length  $L_1$  being greater than the length  $L_2$  by at least 10 cm.

53. The highway crash cushion of claim 52 wherein the length  $L_1$  is greater than the length  $L_2$  by at least 30 cm.

30 54. The highway crash cushion of claim 52 wherein each said fender panel defines a plurality of ridges extending generally parallel to the side edge, and wherein the first portion of the trailing edge is positioned in a groove of the fender panel, between adjacent ones of the ridges.

55. The highway crash cushion of claim 52 wherein the first portion is positioned centrally along the trailing edge.

56. The highway crash cushion of claim 55 wherein the second portion is positioned adjacent the side edge.



57. The highway crash cushion of claim 43 wherein at least some of the fender panels comprise:

a rigid elongated metal element comprising four parallel ridges separated by three parallel grooves;

5 said grooves comprising a central groove and two lateral grooves;

said central groove forming a slot extending parallel to the ridges, said slot extending over a length at least one half the length of the fender panel;

said grooves each having a respective width transverse to the slot, said central groove width being greater than each of the lateral groove widths.

10 58. The highway crash cushion of claim 57 further including a plurality of fasteners, each fastener passing through the respective slot and secured to the crash cushion to allow the respective fender panel to slide relative to the fastener.

59. The highway crash cushion of claim 57 or claim 58 wherein the central groove is substantially flat over the entire central groove width.

15 60. The highway crash cushion of claim 57 or claim 58 wherein the ridges are substantially equal in height.

61. The highway crash cushion of claim 43 wherein at least one of the energy absorbing elements comprises:

20 an indicator movably mounted on the energy absorbing element to move between first and second positions, said indicator visible from outside of the energy absorbing element in at least the second position;

a retainer coupled to the energy absorbing element to retain the indicator in the first position prior to distortion of the energy absorbing element;

25 said retainer positioned and configured such that distortion of the energy absorbing element beyond a selected amount releases the indicator from the retainer.

62. The highway crash cushion of claim 61 further including a spring coupled to the indicator to bias the indicator to the second position.

30 63. The highway crash cushion of claim 61 wherein the indicator is positioned alongside the energy absorbing element in the first position, and the indicator extends outwardly from the energy absorbing element in the second position.

64. The highway crash cushion of claim 61 wherein the indicator is movably mounted on the energy absorbing element at a first location, the retainer is coupled to the energy absorbing element at a second location, and the retainer is positioned and configured such that compression of the energy absorbing element by

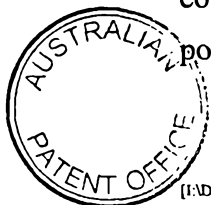

more than the selected amount between the first and second locations releases the indicator from the retainer.

65. The highway crash cushion of claim 64 wherein the energy absorbing element comprises a housing, wherein the first and second locations are located on the housing, and wherein the housing forms a zone of increased compressibility between the first and second locations.

66. The highway crash cushion of claim 61 wherein the indicator comprises a lip, the retainer overlaps the lip by a distance, and the distance corresponds to the selected amount of distortion.

67. A highway crash cushion, substantially as herein described with reference to any one of the embodiments of the invention shown in the accompanying drawings.

**Dated 26 September, 2000**

**Energy Absorption Systems, Inc.**

**Patent Attorneys for the Applicant/Nominated Person**

**SPRUSON & FERGUSON**

15

SPRUSON & FERGUSON

SPRUSON & FERGUSON

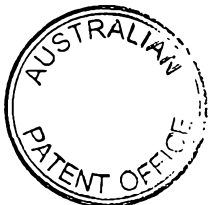

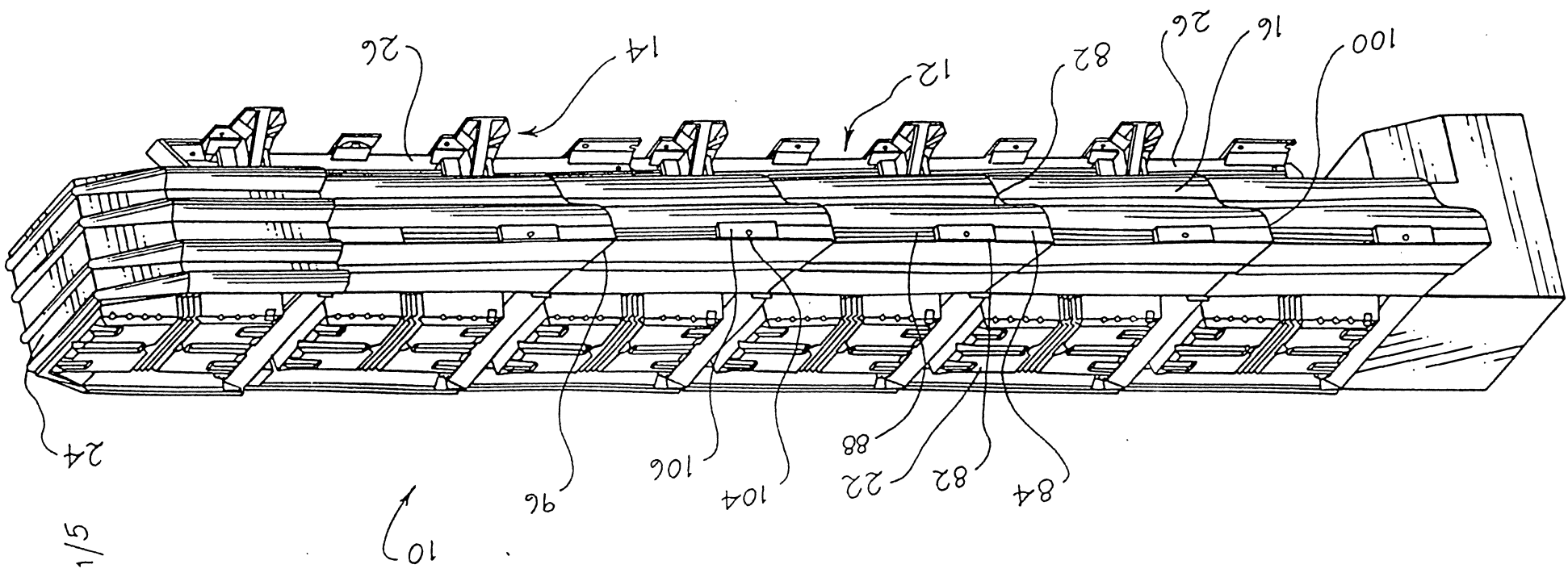
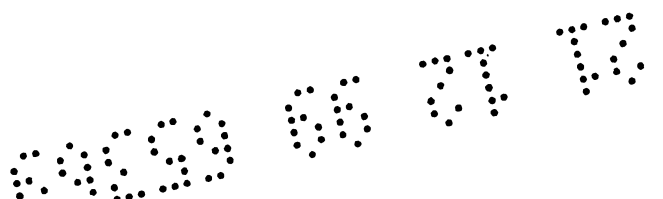

Fig. 1



11 12 13 14 15 16 17 18 19 20 21 22 23 24 25 26 27 28 29 30 31 32 33 34 35 36 37 38 39 40 41 42 43 44 45 46 47 48 49 50 51 52 53 54 55 56 57 58 59 60 61 62 63 64 65 66 67 68 69 70 71 72 73 74 75 76 77 78 79 80 81 82 83 84 85 86 87 88 89 90 91 92 93 94 95 96 97 98 99 100

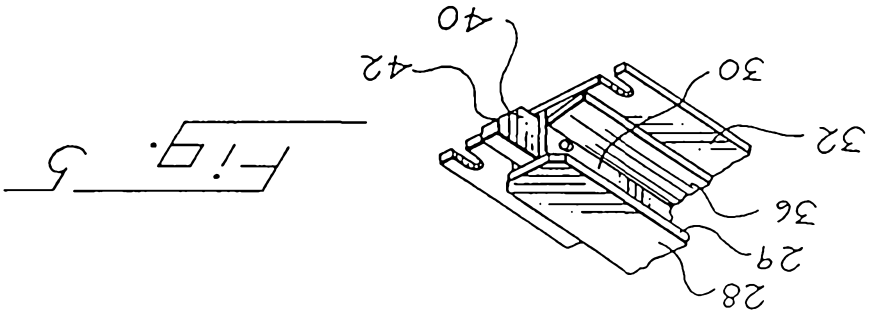
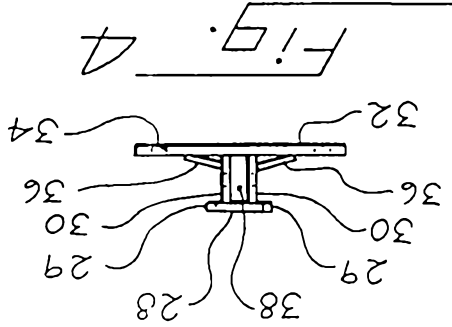
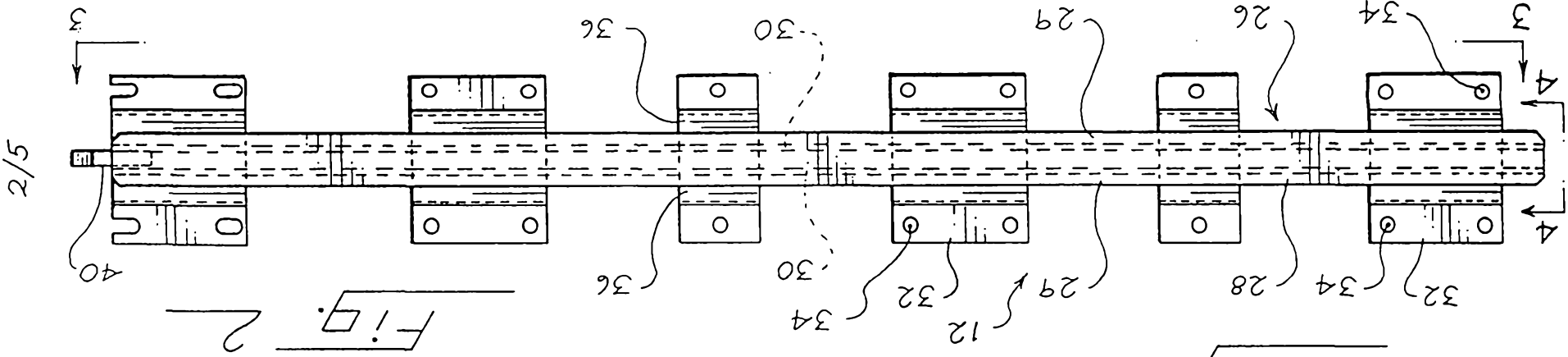
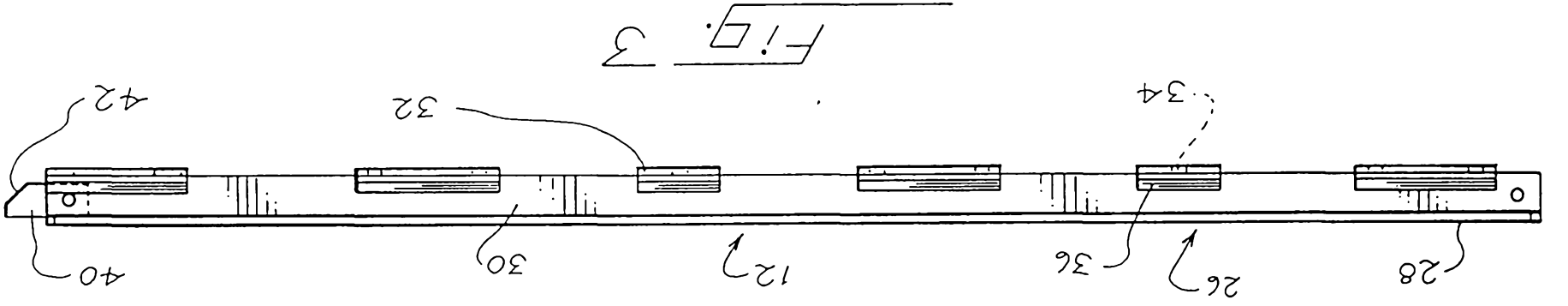

FIG. 6

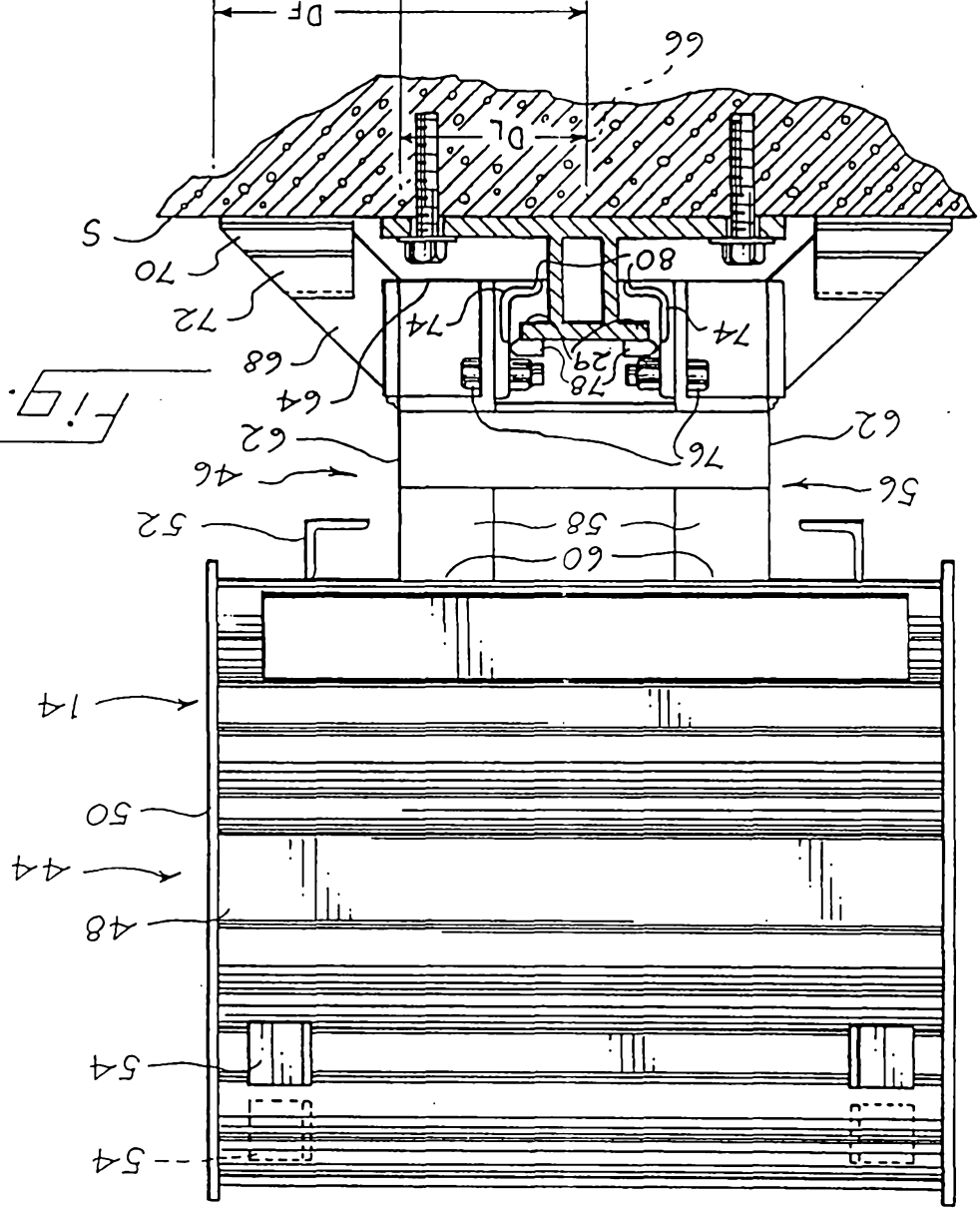

FIG. 6

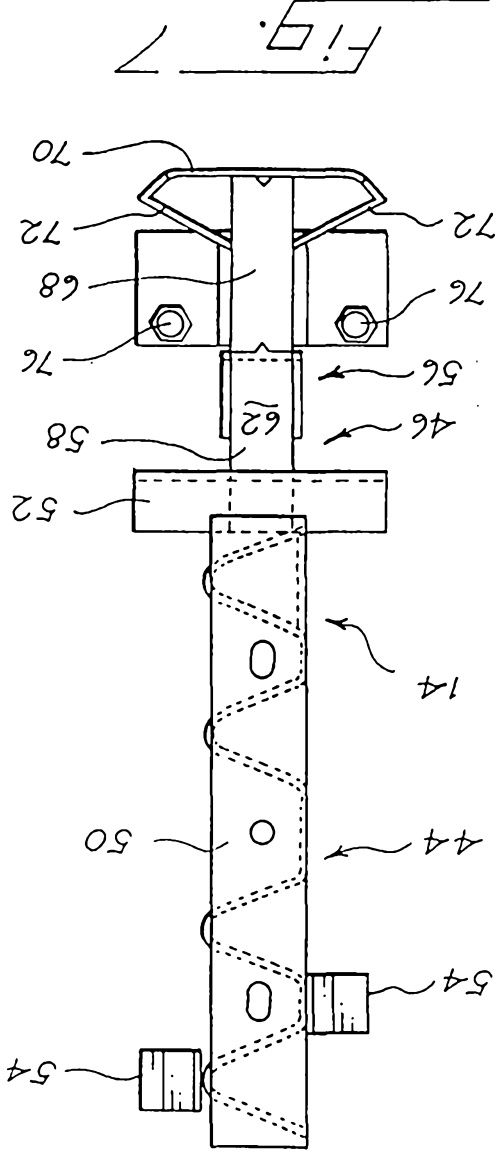

FIG. 7

3/5



5/5

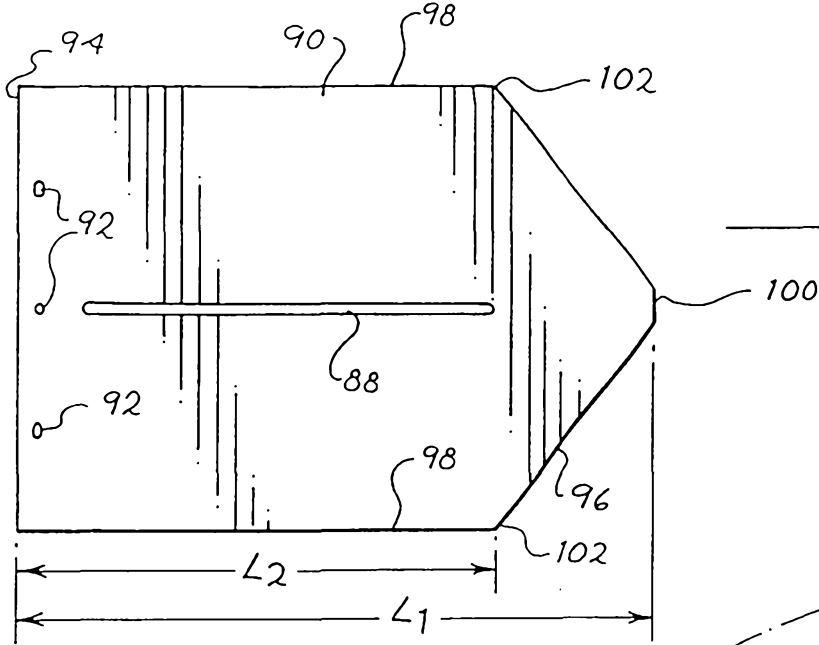

Fig. 12

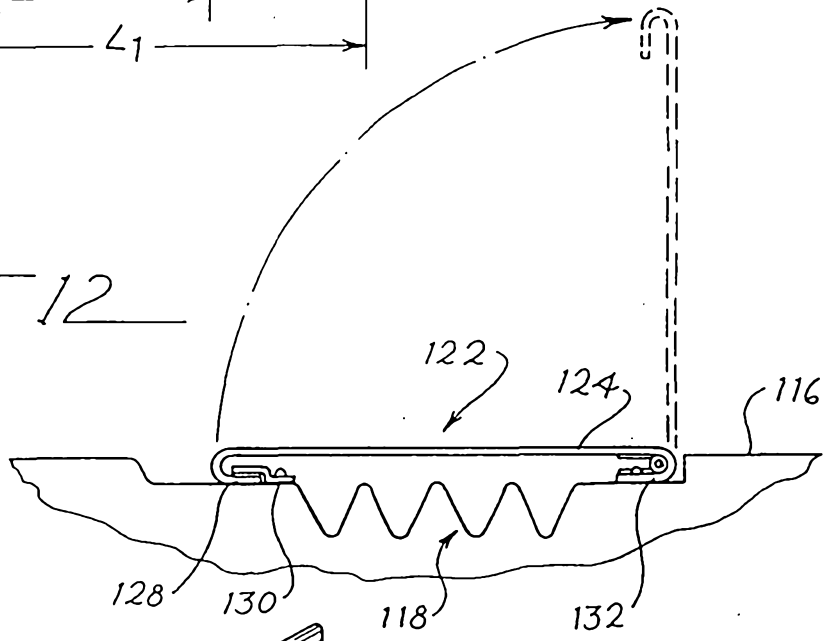

Fig. 11

