

Feb. 17, 1953

E. E. AYLOR  
PENCIL POINTER

2,628,593

Filed April 22, 1949

2 SHEETS—SHEET 1

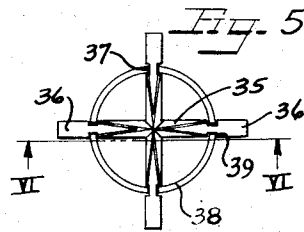
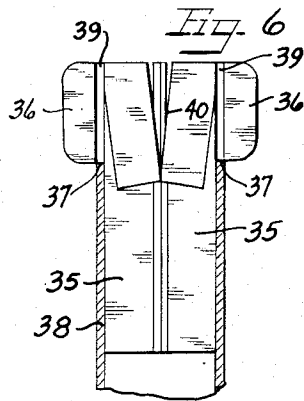
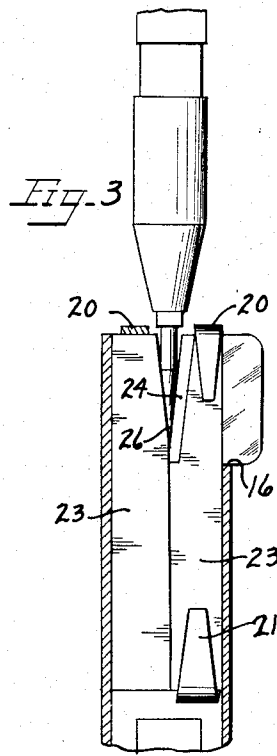
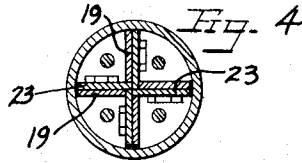
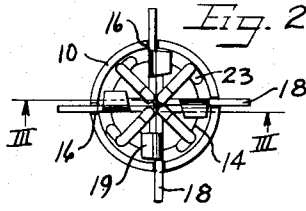
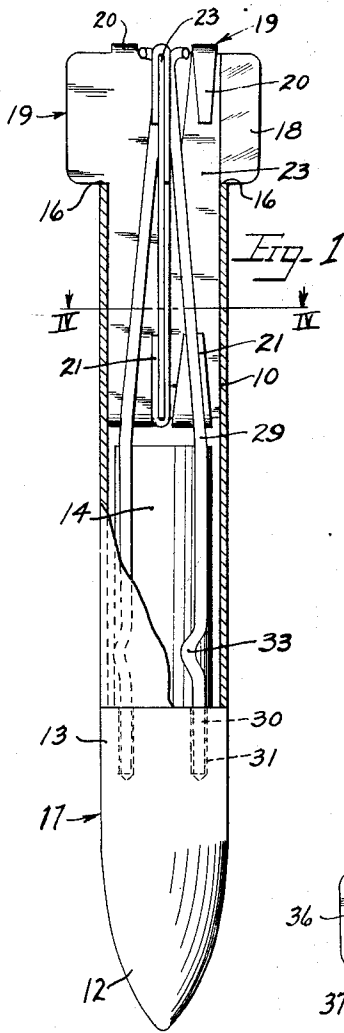

*Inventor*  
ELMO E. AYLOR

*By* Robert J. Newman *Atty.*  
Francis W. Anderson *Agent*

Feb. 17, 1953

E. E. AYLOR  
PENCIL POINTER

2,628,593

Filed April 22, 1949

2 SHEETS—SHEET 2

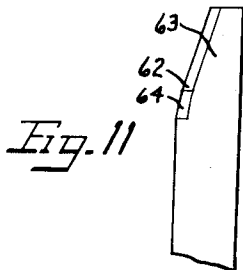
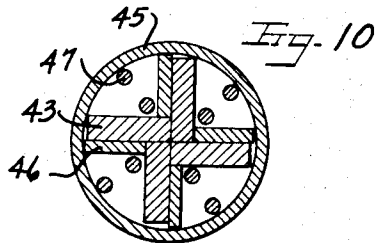
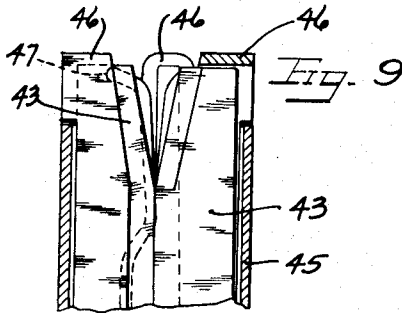
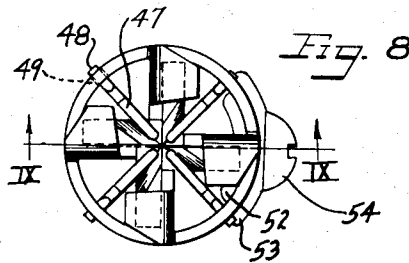
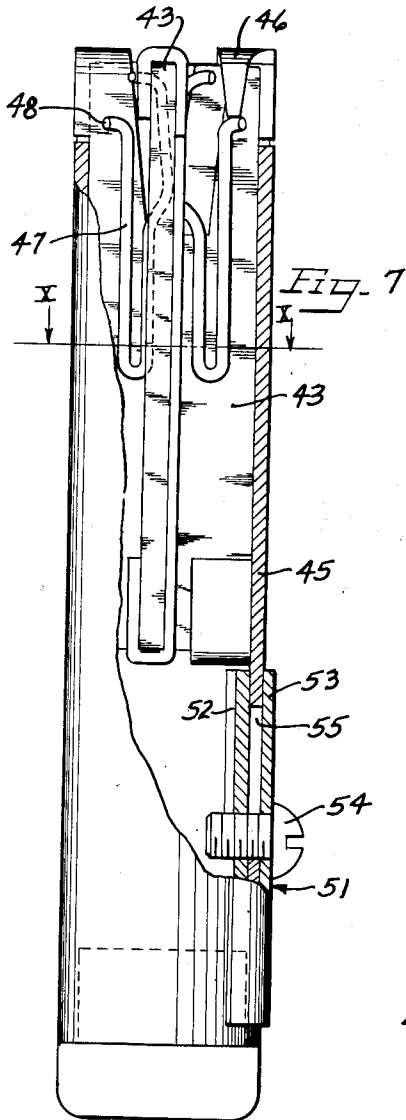

Inventor  
ELMO E. AYLOR

by

Robert J. Newman Atty.  
Francis W. Anderson Agent

# UNITED STATES PATENT OFFICE

2,628,593

## PENCIL POINTER

Elmo Edison Aylor, Chicago, Ill.

Application April 22, 1949, Serial No. 89,104

13 Claims. (Cl. 120—92)

1

This invention relates to improvements in a pencil pointer. More particularly it has to do with an apparatus for putting a point on the end of the replaceable lead of a standard draftsman's pencil.

At present a large percentage of draftsmen use a tubular holder, a chuck at one end thereof and a long replaceable lead that extends into the hollow interior of the holder. The chuck holds the lead in place with the required length projecting out of the holder. It is customary to put a point on these leads by means of a sandpaper block or by means of a file. Neither the sandpaper nor the file are efficient tools for this purpose since the resulting shape of the point is entirely dependent upon the skill of the operator. Further, these instruments become clogged with graphite dust and are constantly depositing the dust on the draftsman's hands and drawings.

It is therefore an object of this invention to provide a pencil pointer having a cutting surface of a definite contour so that a lead manipulated thereagainst will be given a predetermined contour.

Another object of this invention is to provide a pencil pointer having blades that may be quickly and easily removed from the unit for replacement purposes or to permit removal of graphite dust that accumulates in the interior of the unit.

A further object of this invention is to provide a pencil pointer having a plurality of blades defining a cutting recess and spring guides for centering the lead in the recess during the sharpening operation and for frictionally gripping the blades to retain them in the unit.

A still further object of this invention is to provide a pencil pointer having a plurality of blades that have abutting, supporting contact with each for rigidifying the blade assembly.

Another and further object is to provide a pencil pointer that is simple in construction and efficient in operation.

Other and further features, objects and advantages of the present invention will be apparent to those skilled in the art from the following detailed description taken in connection with the accompanying drawings.

On the drawings:

Figure 1 is a front elevational view partly in section and partly broken away, of a pencil pointer constructed in accordance with the teachings of the present invention.

Figure 2 is a top plan view of the pencil pointer of Figure 1.

2

Figure 3 is a fragmentary, vertical sectional view taken on line III—III of Figure 2, showing a lead in position for sharpening.

Figure 4 is a horizontal sectional view taken on line IV—IV of Figure 1.

Figure 5 is a top plan view of a second embodiment of the pencil pointer of this invention, spring guides being omitted in this view to more clearly illustrate the invention.

Figure 6 is a fragmentary, vertical sectional view taken on line VI—VI of Figure 5.

Figure 7 is a front elevational view, partly in section and partly broken away, of a third embodiment of the pencil pointer of this invention.

Figure 8 is a top plan view of the pencil pointer of Figure 7.

Figure 9 is a fragmentary, vertical sectional view taken on line IX—IX of Figure 8.

Figure 10 is a horizontal sectional view taken on line X—X of Figure 7.

Figure 11 is an elevational view of a modified blade structure.

As shown on the drawings:

In Figures 1 to 4 inclusive the reference numeral 10 indicates a tubular casing which is closed at one end by a cap 11. The cap has a pointed end portion 12 of generally ogival configuration, a cylindrical body portion 13 of the same diameter as the casing and a cylindrical portion 14 of reduced diameter that extends into the casing and is uniformly spaced from the interior wall thereof.

At the other end, the casing 10 has four longitudinal slots 16 extending from the end of the casing part way along the length of the casing. These slots 16 are spaced at 90° from each other and each slot is arranged to receive a tab 18 of a blade holder 19. Each holder 19 has bent-over end portions 20 and 21 which press against and retain a blade 23. The blade 23 may be curved longitudinally so that, when held in a straightened position in the holder 19, the resiliency of the blade will help retain the blade in place.

Thus, each of the four blades 23 is held in a holder 19 which is supported in a slot 16 of the casing 10.

As best seen in Figure 3 each blade 23 has a generally rectangular shape having an upper corner 24 cut off diagonally. This diagonal corner portion 24, in cooperation with the similar diagonal corner portions of the other three blades, define a cone-shaped recess into which the end of the lead is inserted, as shown in Figure 3. A wedge-shaped point is provided on these diagonal corners by slanting the surface on one side

3

of the blade adjacent the corner while keeping the surface on the other side of the blade in a flattened condition.

It is to be particularly noted that the blades, as held in the casing by the holders, have their cutting edges on major diameters of the cylinder casing so that the cone-shaped recess defined by these edges is centered in the casing.

In Figure 4 is illustrated the abutting contact of the inner edges of the blades below the cutting edges. The inner edge of each blade abuts the side of an adjacent blade while the blade is so sized in relation to the inside diameter of the casing that the outer edge of the blade is in close contact with the inner wall of the casing. It is to be further noted that the inner longitudinal edge of each holder abuts the side of an adjacent blade while its outer longitudinal edge bears against the inner wall of the casing. This inter-engagement of the edges of the blades, the holders and the casing provides an automatic centering means and helps to retain the blades in the casing.

To center the lead during the sharpening operation there is provided four longitudinal spring guides 29 which have their lower ends 30 retainingly engaged in recesses 31 in the end plug member 11. The guides are disposed in the space between the casing 10 and the reduced cylindrical portion 14 of the plug 11 and have offset bent portions 23 in this space which prevent rotation of the guides 29. Above the reduced portion 14 the spring guides are slanted inwardly so that their upper edges converge into the cone shaped recess. The guides are so located that there is one between each pair of blades.

Thus, the spring guides 29 resiliently engage the lead being sharpened and hold it in place. These guides also bear against the adjacent blades and holders and exert a frictional force tending to hold the blade and holder assemblies in the casing.

It will also be seen that the spring guides 29 fit snugly, at their lower portions, between the casing 10 and the reduced portion of the plug 12 and help to retain the plug on the casing.

In Figures 5 and 6 a second embodiment of the pencil pointer is illustrated. In this embodiment no blade holder is necessary because the blade 35 has a tab portion 36 formed integral therewith which is adapted for support in a slot 37 of a cylindrical casing 38. As seen in Figure 5, the blade has longitudinal grooves 39 on the opposite faces of the blades between the tab 36 and the body portion of the blade. The walls of the grooves 39 fit closely against the walls of the casing and tend to hold the blade in place.

The inner edge of the blade 35 is V-shaped from the upper edge to the lower edge. The upper portion of the inner edge of the blade is cut off diagonally as at 40. The V-shaped edge at this upper diagonal portion is cut back entirely to grooves 39. It is to be noted that the cutting edge of the blade is on the major diameter of the cylindrical casing so that these edges of the four angular spaced blades define a conical recess that is centered in the casing.

In Figure 5 it is seen that the V-shaped inner edges of the blades below the cutting edges abut each other and reinforce and support each other. While no guide springs are shown in Figures 5 and 6, it is to be understood that spring guides exactly like those shown in Figures 1 and 2 are used in this embodiment also.

A third embodiment of this invention is illus-

4

trated in Figures 7, 8, 9 and 10. In this form four blades 43, similar to the blades 23 of Figure 1, are supported in holders 46 in a casing 45 with their diagonal cutting edges defining a cone-shaped recess. Hairpin type spring guides 47 are anchored in the casing 45 by end portions 48 which project through apertures 49 in the casing.

This embodiment features a slide assembly 51 including an inner arcuate plate 52, an outer arcuate plate 53 and a capscrew 54 which passes through a longitudinal slot 55 in the casing 45 and connects the plates 52 and 53. The upper edge of the inner plate 52 is arranged to abut the lower edge of one of the blades and provides a means for quickly sliding said one blade out of the casing for the purpose of removing graphite dust and chips from the inside of the casing.

In Figure 11 is illustrated a modified blade that may be used in connection with any of the holding devices hereinbefore disclosed. This blade has a cutting edge 62 defined by two slanted portions 63 and 64. With four such blades assembled in a casing, the point formed on the lead will have an upper frusto-conical portion and a lower conical portion. The lower conical portion is, of course, the part of the lead that is worn in use. By making this conical end portion of extended length, the period of service before re-sharpening is necessary can be extended.

From the foregoing description it is seen that there is provided in this invention an efficient pencil pointer having spring guides for centering the lead as it is being sharpened and for frictionally holding the blades in place in the casing.

I claim as my invention:

1. A pencil pointer comprising a casing, a plurality of spaced blades disposed in said casing defining a cutting recess, and resilient guide members disposed between adjacent blades and extending into said recess for automatically centering a pencil in said recess.

2. A pencil pointer comprising a casing, a plurality of blades disposed in said casing defining a cutting recess, and resilient guide members having free end portions projecting into said cutting recess to center a pencil therein.

3. A pencil pointer comprising a casing, a plurality of spaced blades disposed longitudinally in said casing and upright resilient guide members anchored in said casing and arranged to bear against said blades to frictionally hold them in position.

4. A pencil pointer comprising an open ended casing, blades slidably disposed in said casing, a cap member closing one end of said casing, and guide rods anchored at one end between said cap member and said casing said rods having end portions extending into the interior of said casing to center a pencil therein in the cutting path of said blades.

5. A pencil pointer comprising a casing, a plurality of blades slidably disposed in said casing, resilient guide rods anchored at one end in said casing and having free end portions extending between said blades and defining a guide passage and abutment arms preventing rotation of said rods said rods being arranged to yield radially outwardly to permit insertion of a pencil lead in said passage and to automatically press radially inwardly thereagainst to center the lead.

6. A pencil pointer comprising a cylindrical casing open at both ends, a cap closing one of said ends and having a reduced diameter portion extending into said casing, a plurality of

5

blades slidably disposed in the other end of said casing having beveled cutting edges defining a cutting recess of substantially cone-shape, and guide rods of resilient material having lower end portions disposed in recesses in said cap and upper end portions slanted inwardly to a point in said recess between said blades for centering a pencil lead inserted therein.

7. A pencil pointer comprising a casing having an interior central passage, a plurality of flat blades disposed in said passage, a holder for each blade, each of said blades and each of said holders having an inner longitudinal edge in abutment with a side face of an adjacent blade.

8. A pencil pointer comprising a casing having a central opening, a plurality of blades in said casing having cooperating cutting edges defining a cutting recess interiorly of said casing and spring guides having end portions anchored in said casing and opposite unsecured end portions converging into said cutting recess.

9. A pencil pointer comprising an elongated cylindrical casing open at both ends and having a plurality of longitudinal slots therein, a plurality of blades of generally rectangular configuration disposed in said casing, each blade having an outer tab portion slidably disposed in one of said slots and an inner cutting edge cooperating with the cutting edges of the other blades to define a cutting zone, a cap covering one of said open ends having a cylindrical portion of reduced diameter extending into said casing, and a plurality of flexible guide rods between said casing and said reduced portions, each guide rod having an end anchored in said cap and a free end slanted inwardly between the upper inner edges of adjacent blades, rotation of said cap being effected to move each rod in a circular path until said rod contacts the lower edge of one of the adjacent blades whereby further rotation will cause said rod to pivot about said contact point moving the upper free end against the inner edge of the other adjacent blade to pivot said blade about its slotted connection in the casing.

10. A pencil pointer comprising a casing, a plurality of spaced blades disposed longitudinally in said casing and upright resilient guide members anchored in said casing arranged to bear against said blades to frictionally hold them in position and arranged to define a yieldable guide means for centering the pencil.

6

11. A pencil pointer comprising a hollow casing, and a plurality of blade-holder units disposed inside said casing having flat side wall portions extending longitudinally therein, each of said units having a longitudinal radially inner edge in abutting supporting contact with a flat side wall of an adjacent unit.

12. A pencil pointer comprising a hollow casing, and a plurality of blade-holder units disposed inside said casing having flat side wall portions extending longitudinally therein, each of said units having a longitudinal radially inner edge in abutting supporting contact with a flat side wall of an adjacent unit, and radially outer edges in contact with the inner wall of said hollow casing.

13. A pencil pointer comprising a hollow casing, and four blade-holder units disposed inside said casing having longitudinal flat side wall portions, each of said units having a longitudinal inner flat edge in abutting supporting contact with a flat side wall portion of an adjacent unit.

ELMO EDISON AYLOR.

REFERENCES CITED

The following references are of record in the file of this patent:

UNITED STATES PATENTS

Number	Name	Date
199,448	Keyes	Jan. 22, 1878
411,909	Tillinghast	Oct. 1, 1889
1,069,831	Traylor	Aug. 12, 1913
1,146,431	La Casse	July 13, 1915
1,254,539	Ruddle et al.	Jan. 22, 1918
1,418,858	Wolcott	June 6, 1922
1,573,244	Hickey	Feb. 16, 1926
2,108,441	Mancher	Feb. 15, 1938
2,140,653	Rohm et al.	Dec. 20, 1938
2,188,130	Baler et al.	Jan. 23, 1940
2,557,646	Fugle	June 19, 1951

FOREIGN PATENTS

Number	Country	Date
282,117	Germany	Feb. 16, 1915
325,455	Germany	June 17, 1919
367,629	Great Britain	Feb. 25, 1932
116,617	Sweden	June 18, 1946