

(12) STANDARD PATENT
(19) AUSTRALIAN PATENT OFFICE

(11) Application No. **AU 2014266921 C1**

(54) Title
A beverage preparation system, a capsule and a method for forming a beverage

(51) International Patent Classification(s)
A47J 31/36 (2006.01) **B65D 85/804** (2006.01)

(21) Application No: **2014266921** (22) Date of Filing: **2014.05.16**

(87) WIPO No: **WO14/184652**

(30) Priority Data

(31) Number	(32) Date	(33) Country
1308925.5	2013.05.17	GB
1308929.7	2013.05.17	GB

(43) Publication Date: **2014.11.20**

(44) Accepted Journal Date: **2017.03.23**

(44) Amended Journal Date: **2018.01.25**

(71) Applicant(s)
Koninklijke Douwe Egberts B.V.

(72) Inventor(s)
Chapman, Andrew;Banister, Stuart;Jelley, Simon;Shabudin, Esak;Halliday, Andrew

(74) Agent / Attorney
Griffith Hack, GPO Box 1285, Melbourne, VIC, 3001, AU

(56) Related Art
WO 2013/136209 A1
WO 2012/118367 A1



- (51) International Patent Classification:
A47J 31/36 (2006.01) B65D 85/804 (2006.01)
- (21) International Application Number:
PCT/IB2014/000858
- (22) International Filing Date:
16 May 2014 (16.05.2014)
- (25) Filing Language: English
- (26) Publication Language: English
- (30) Priority Data:
1308925.5 17 May 2013 (17.05.2013) GB
1308929.7 17 May 2013 (17.05.2013) GB
- (71) Applicant: **KRAFT FOODS R&D, INC.** [US/US]; Three Parkway North, Deerfield, IL 60015 (US).
- (72) Inventors: **CHAPMAN, Andrew**; 1 The Ashes, Peterborough, Cambridgeshire PE7 0LA (GB). **BANISTER, Stuart**; 59 Allan Avenue, Peterborough, Cambridgeshire PE2 8TN (GB). **JELLEY, Simon**; 4 Farringford Close, Cambridge, Cambridgeshire CB4 3LU (GB). **SHABUDIN, Esak**; Mondelez UK R&D Limited, Ruscote Avenue, Banbury, Oxon OX16 2QU (GB). **HALLIDAY, Andrew**; Mondelez UK R&D Limited, Ruscote Avenue, Banbury, Oxon OX16 2QU (GB).

(81) Designated States (unless otherwise indicated, for every kind of national protection available): AE, AG, AL, AM, AO, AT, AU, AZ, BA, BB, BG, BH, BN, BR, BW, BY, BZ, CA, CH, CL, CN, CO, CR, CU, CZ, DE, DK, DM, DO, DZ, EC, EE, EG, ES, FI, GB, GD, GE, GH, GM, GT, HN, HR, HU, ID, IL, IN, IR, IS, JP, KE, KG, KN, KP, KR, KZ, LA, LC, LK, LR, LS, LT, LU, LY, MA, MD, ME, MG, MK, MN, MW, MX, MY, MZ, NA, NG, NI, NO, NZ, OM, PA, PE, PG, PH, PL, PT, QA, RO, RS, RU, RW, SA, SC, SD, SE, SG, SK, SL, SM, ST, SV, SY, TH, TJ, TM, TN, TR, TT, TZ, UA, UG, US, UZ, VC, VN, ZA, ZM, ZW.

(84) Designated States (unless otherwise indicated, for every kind of regional protection available): ARIPO (BW, GH, GM, KE, LR, LS, MW, MZ, NA, RW, SD, SL, SZ, TZ, UG, ZM, ZW), Eurasian (AM, AZ, BY, KG, KZ, RU, TJ, TM), European (AL, AT, BE, BG, CH, CY, CZ, DE, DK, EE, ES, FI, FR, GB, GR, HR, HU, IE, IS, IT, LT, LU, LV, MC, MK, MT, NL, NO, PL, PT, RO, RS, SE, SI, SK, SM, TR), OAPI (BF, BJ, CF, CG, CI, CM, GA, GN, GQ, GW, KM, ML, MR, NE, SN, TD, TG).

Published:
— with international search report (Art. 21(3))

(54) Title: A BEVERAGE PREPARATION SYSTEM, A CAPSULE AND A METHOD FOR FORMING A BEVERAGE

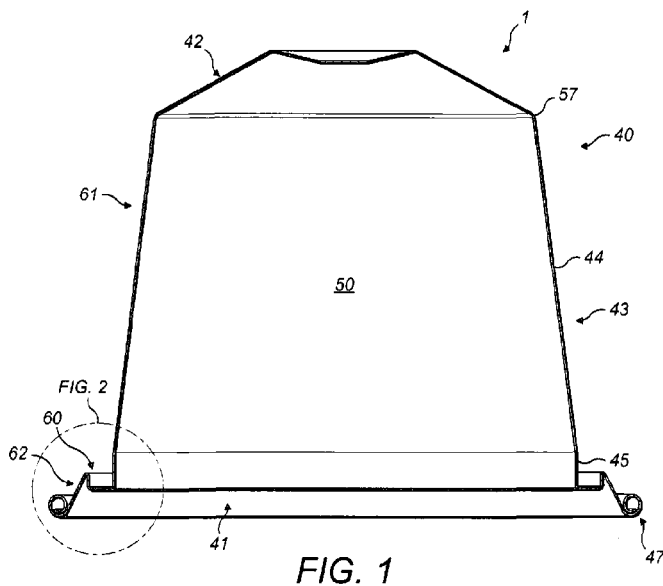

(57) Abstract: A beverage producing system is provided comprising a capsule containing beverage ingredients and a beverage preparation machine. The capsule comprises a cup-shaped body and a lid; the cup-shaped body having a base and a side wall and the lid being sealed to the cup-shaped body. Prior to insertion, the side wall comprises: - an annular trough being dimensioned to receive an enclosing member of the beverage preparation machine on movement of the enclosing member, into a closed position; - a first side wall section extending between the base and the annular trough; and - a second side wall section extending between the annular trough and a rim of the capsule. A capsule and a method are also disclosed.

WO 2014/184652 A1

A Beverage Preparation System, a Capsule and a Method for
forming a Beverage

The present disclosure relates to a beverage
5 preparation system, a capsule and a method for forming a
beverage. The beverage preparation system is of the type
comprising a beverage preparation machine wherein the
capsule is designed for insertion into the beverage
preparation machine to permit a pressurised liquid to be
10 flowed through the capsule in order to produce a beverage
from interaction with beverage ingredients contained within
the capsule.

Background

15 Beverage preparation systems which comprise a beverage
preparation machine and a capsule containing beverage
ingredients are known in the art. One such system is taught
in EP 1700548, which discloses a capsule comprising a cup-
like base body and a closing foil member. The capsule is
20 designed for insertion in a beverage production device in
which a liquid under pressure enters the capsule in order to
interact with ingredients in the capsule to form a beverage
which is output for consumption. The capsule of EP 1700548
is provided with a dedicated sealing member to prevent a by-
25 pass flow of water around the exterior of the capsule in
use. The sealing member is in the form of a hollow sealing
member on the outer surface of the capsule, for example in
the form of a step which is contacted on closure of an
enclosing member of the beverage preparation machine.

30 The present disclosure provides an alternative capsule
which may be used as part of such a beverage preparation

system. The capsule may be economical to produce and provide effective sealing in use.

Summary of the Disclosure

5 In a first aspect the present disclosure provides a beverage producing system comprising:
 a capsule containing beverage ingredients; and
 a beverage preparation machine;
 the capsule comprising a cup-shaped body and a lid; the
10 cup-shaped body having a base and a side wall and the lid being sealed to the cup-shaped body;
 the capsule being designed for insertion into the beverage preparation machine to permit a pressurised liquid to be flowed through the capsule in order to produce a
15 beverage from interaction with the beverage ingredients;
 the beverage preparation machine having an enclosing member adapted to be selectively movable between an open position to permit insertion of the capsule into the beverage preparation machine and a closed position in which
20 the enclosing member sealingly engages the capsule;
 wherein, prior to insertion, the side wall comprises:
 - an annular trough being dimensioned to receive the enclosing member on movement of the enclosing member into the closed position;
25 - a first side wall section extending between the base and the annular trough; and
 - a second side wall section extending between the annular trough and a rim of the capsule;
 wherein the cup-shaped body is formed from aluminium, an aluminium alloy or a laminate comprising at least one layer formed from aluminium or an aluminium alloy;
 wherein the first side wall section, the second side wall section and the annular trough are formed integrally;
 and
 wherein the annular trough is adapted to form a sealing interface with a leading edge of the enclosing

2014266921 24 Feb 2017

2014266921 24 Feb 2017

member and the side wall is adapted such that during closure of the enclosing member the side wall is plastically drawn over the leading edge of the enclosing member.

30 In a second aspect, the present disclosure provides a capsule for preparing a beverage comprising a cup-shaped body and a lid; the cup-shaped body having a base and a side wall and the lid being sealed to the cup-shaped body;

the capsule being designed for insertion into a beverage preparation machine to permit a pressurised liquid
5 to be flowed through the capsule in order to produce a beverage from interaction with the beverage ingredients;

the beverage preparation machine being of the type having an enclosing member adapted to be selectively movable between an open position to permit insertion of the capsule
10 into the beverage preparation machine and a closed position in which the enclosing member sealingly engages the capsule;

wherein the side wall comprises:

- an annular trough being dimensioned to receive the enclosing member;
15 - a first side wall section extending between the base and the annular trough; and

- a second side wall section extending between the annular trough and a rim of the capsule;

wherein the cup-shaped body is formed from aluminium, an aluminium alloy or a laminate comprising at least one layer formed from aluminium or an aluminium alloy;

wherein the first side wall section, the second side wall section and the annular trough are formed integrally; and

wherein the annular trough is adapted to form a sealing interface with a leading edge of the enclosing member and the side wall is adapted such that during closure of the enclosing member the side wall is plastically drawn over the leading edge of the enclosing member.

2014266921 24 Feb 2017

- 20 In a third aspect the present disclosure provides a method for preparing a beverage comprising the steps of:
- providing a capsule as described above;
 - providing a beverage preparation machine having an enclosing member;
 - 25 - moving the enclosing member into an open position;
 - inserting the capsule into the beverage preparation machine;
 - closing the enclosing member so as to sealingly engage the enclosing member with the capsule;
 - 30 - flowing a pressurised liquid through the capsule to produce a beverage from interaction with the beverage ingredients; and
 - outputting the beverage for consumption;
- wherein on closure, the enclosing member engages the annular trough of the side wall of the capsule to thereby deform the side wall;
- 5 wherein said deformation of the side wall causes the formation of at least one sealing interface between the enclosing member and the side wall.

The above aspects may further comprise one or more of the following features:

10

The annular trough may be dimensioned to partially or wholly receive a leading edge of the enclosing member therein on movement of the enclosing member into the closed position.

15

The second side wall section may define a ridge zone located radially outwards of the annular trough.

The side wall may be adapted to undergo plastic deformation during closure of the enclosing member.

20 The side wall may be adapted such that, in use, closure of the enclosing member deforms the side wall to cause the second side wall section to be forced inwardly against an

2014266921 24 Feb 2017

outer face of the enclosing member to form a sealing interface with the outer face of the enclosing member.

25 The annular trough may be adapted to form a sealing interface with a leading edge of the enclosing member.

Advantageously, a sealing interface may be provided with both the leading edge and the outer face of the enclosing member. In addition, the deformation of the annular trough may also cause an outward pressure to be exerted by the side wall on the inner face of the enclosing member to form a further sealing interface.

The side wall may be adapted such that during closure of the enclosing member the side wall is plastically drawn over the leading edge of the enclosing member. Advantageously this may allow the side wall to be conformed to the shape of any grooves (or similar) provided in the leading edge.

Prior to insertion, the annular trough may comprise an inner wall, an outer wall and a floor. On closure of the enclosing member a leading edge of the enclosing member may contact the outer wall of the annular trough and form a seal therewith.

The inner wall and outer wall may be substantially perpendicular to the floor. In an alternative arrangement the outer wall may be angled relative to the floor, such that an internal angle at a junction between the floor and the outer wall is from 90° to 120°, preferably 105°. Thus the seal with the enclosing member may be a tapered seal.

The ridge zone may comprise an apex, and a leading edge of the enclosing member may comprise an inner rim and an outer rim and a recess located between the inner rim and the outer rim, wherein on closure of the enclosing member the apex of the ridge zone may be received in the recess between the inner rim and the outer rim.

The annular trough may be adapted to be nipped against a capsule holder of the beverage preparation machine part.

Prior to insertion, a floor of the annular trough may

2014266921 24 Feb 2017

30 be raised relative to the rim. The floor of the annular
trough may be offset from a distal end of the side wall by a
distance from 0.1 to 2.0 mm. In one example, the offset may
be relatively large, for example it may be from 1.55 to 2.0
mm. In a specific example the offset may be 1.85 mm. Where
the offset is relatively large, the floor of the annular
trough may be from 0.75 to 1.2 mm below an apex of the ridge
zone (where present). In one example, the distance may be
0.9 mm. In another example, prior to insertion, the floor of
the annular trough may be substantially level with the rim.
5 For example the offset may be 0.1 to 0.5 mm. In one example
the offset may be 0.2 mm. In this alternative arrangement
the floor of the annular trough may be from 2.0 to 2.5 mm
below an apex of the ridge zone (where present). In one
example, the distance is 2.2 mm.

10 The side wall may be adapted such that, in use, closure
of the enclosing member deforms the side wall to cause the
floor of the annular trough to be brought substantially into
alignment with the rim.

15 The first side wall section, annular trough and second
side wall section may be formed integrally.

The rim may be formed integrally with the cup-shaped
Body

• The rim may be formed by a rolled-over portion of the
side wall.

20 Prior to insertion, the side wall may comprise a
frustoconical section proximate the base.

Prior to insertion, the side wall may comprise a
cylindrical section between the frustoconical section and
the annular trough.

25 The annular trough may have an internal width of from
1.3 to 2.0 mm. In one example, the annular trough has an
internal width of approximately 1.5 mm to 1.8 mm.

The annular trough may have an internal diameter of
from 27.5 to 30.0 mm and an outer diameter of from 29.3 to
30 32.5 mm.

The lid may be sealed to the annular trough of the side wall. The lid may be sealed to an inner surface of a floor of the annular trough.

5 A leading edge of the enclosing member may comprise a plurality of grooves or indentations, and the side wall may be adapted such that the plastic deformation of the side wall conforms the annular trough of the side wall to the grooves or indentations to provide an effective seal. In one arrangement the plastic deformation of the side wall
10 conforms the outer wall of the annular trough to the grooves or indentations to provide an effective seal.

At least a portion of the cup-shaped body, preferably a whole of the cup-shaped body, may be formed from aluminium, an aluminium alloy or a laminate comprising at least one
15 layer formed from aluminium or an aluminium alloy. A lacquer layer may be applied to one or both faces of the cup-shaped body. Alternatively, another, suitably ductile material could be utilised in place of the aluminium or aluminium alloy.

20 The aluminium alloy may, for example, be of grade 3005, 3105, 8011 or 8079. Preferably, the aluminium alloy will have an 'O' temper rating.

The laminate, where used, may comprise a ductile structural layer formed from a material such as aluminium or
25 an aluminium alloy together with a resilient layer formed from a polymer. The laminate may comprise only a single layer of aluminium or aluminium alloy together with a single layer of polymer together with one or more optional lacquer layers, tie layers or adhesive layers applied to the
30 aluminium or aluminium alloy.

The cup-shaped body may comprise a unitary piece of laminate material.

2014266921 24 Feb 2017

The polymer layer may, for example, comprise a material selected from the group of: polyvinyl chloride (PVC), polypropylene (PP), low density polyethylene (LDPE), medium density polyethylene (MDPE), high density polyethylene
5 (HDPE), fluorinated ethylene propylene (FEP), polytetrafluoroethylene (PTFE), polyethylene terephthalate (PET), polyamide (PA), ethylene propylene diene monomer (EPDM), polychloroprene or isobutylene.

The polymer of the polymer layer preferably has a
10 hardness of less than or equal to 40 D Shore Hardness. Advantageously, using a relatively soft polymer for the outer layer of the laminate allows the material to deform around imperfections and features of the enclosing member to provide a more effective hydraulic seal.

15 The lid may be formed from aluminium, an aluminium alloy or a laminate comprising at least one layer formed from aluminium or an aluminium alloy. Alternatively, another, suitably ductile material could be utilised. The lid may further comprise a heat seal lacquer or heat seal
20 layer to enhance sealing of the lid to the cup-shaped body.

The cup-shaped body may be formed from a single integral piece of material. The single piece of material may be cold drawn to form the shape of the cup-shaped body, including the annular trough. A deep-drawing technique may
25 be used to cold form the cup-shaped body. Where the material of the cup-shaped body comprises a laminate with a polymer layer, a warm-drawing technique may be used where the material is subjected to an increased temperature to promote easier deformation of the polymer material but without
30 detrimental effects on the material characteristics of the aluminium layer.

The cup-shaped body and rim may be integral.

2014266921 24 Feb 2017

The cup-shaped body may have a thickness in the range of 80 to 500 microns. In some aspects the thickness may be in the range of 90 to 300 microns. Where the cup-shaped body is formed solely from aluminium or an aluminium alloy
5 (optionally with one or more lacquer layers) a thickness in the range of 80 to 120 microns may be preferred. Where the cup-shaped body is formed from a laminate material comprising a polymer layer a thickness in the range 100 to 500 microns is preferred. The thickness of the material may
10 be varied throughout the cup-shaped body.

The rim may have an outer diameter of approximately 37 mm

Prior to insertion, the capsule may have a height of from 25 to 31 mm. In some aspects the height may be from
15 28.5 to 30 mm. Deformation of the capsule during use will tend to reduce the longitudinal height.

Preferably, the cup-shaped bodies may be shaped in a way that can be stacked and destacked easily prior to filling and assembly with the lids.

20 The capsule may form a single-use, disposable element.

The capsule may contain a beverage ingredient or mixture of beverage ingredients. As a non-limiting example, the beverage ingredient may comprise roasted ground coffee.

25 Brief Description of the Drawings

Examples of the present disclosure will now be described in more detail, for exemplary purposes only, with reference to the accompanying drawings, in which:

30

Figure 1 is a cross-sectional view of a first embodiment of capsule according to the present disclosure;

2014266921 24 Feb 2017

Figure 2 is an enlarged view of a detail of Figure 1;
Figure 3 is a schematic illustration of the capsule of
Figure 1 together with an enclosing member of a beverage
preparation machine;
5 Figure 4 is an enlarged view of a detail of Figure 3;
Figure 5 is a schematic illustration of the arrangement
of Figure 3 with the enclosing member in a closed position;
Figure 6 is an enlarged view of a detail of Figure 5;
Figure 7 is a cross-sectional view of a second
10 embodiment of capsule according to the present disclosure;
Figure 8 is an enlarged view of a detail of Figure 7;
Figure 9 is a schematic illustration of the capsule of
Figure 7 together with an enclosing member of a beverage
preparation machine;
15 Figure 10 is an enlarged view of a detail of Figure 9;
Figure 11 is a schematic illustration of the
arrangement of Figure 9 with the enclosing member in a
closed position;
Figure 12 is an enlarged view of a detail of Figure 11;
20 Figure 13 is a cross-sectional view of a third
embodiment of capsule according to the present disclosure;
Figure 14 is an enlarged view of a detail of Figure 13;
Figure 15 is a schematic illustration of the capsule of
Figure 13 together with an enclosing member of a beverage
25 preparation machine;
Figure 16 is an enlarged view of a detail of Figure 15;
Figure 17 is a schematic illustration of the
arrangement of Figure 15 with the enclosing member in a
closed position; and
30 Figure 18 is an enlarged view of a detail of Figure 17.

Detailed Description

2014266921 24 Feb 2017

Figure 3 shows schematically a part of a beverage preparation system according to the present disclosure. The beverage preparation system comprises a beverage preparation machine and a capsule 1.

Figures 1 and 2 show a first embodiment of capsule 1. The capsule 1 will be described in more detail below but may have the general form of a cup-shaped body 40 having a base 42 at one end and a side wall 43 extending from the base 42 towards an opposed end which is closed-off by a lid 41.

As shown in Figure 3, the beverage preparation machine comprises an enclosing member 2 and a capsule holder 20. The enclosing member 2 is selectively movable relative to a capsule holder 20 between an open position, to permit insertion of the capsule 1 into the beverage preparation machine, and a closed position, in which the enclosing member 2 sealingly engages the capsule 1 against the capsule holder 20 in a manner that will be described below.

The enclosing member 2 may be moved between the open and closed positions by means of a conventional mechanism well known in the art. For example, the means may involve a mechanical mechanism activated by a manually-movable lever or an automatic or semi-automatic mechanism where movement is driven by a motor. The enclosing member 2 may be moved while the capsule holder 20 remains stationary. Alternatively, the enclosing member 2 may remain stationary and the capsule holder 20 be moved. In a further alternative arrangement, both the enclosing member 2 and the capsule holder 20 may move during the opening and closing operations.

2014266921 24 Feb 2017

The enclosing member 2 and the capsule holder 20 in the closed position together define a receptacle 3 for holding the capsule 1 during a dispensing operation.

The beverage preparation machine may further comprise
5 other conventional elements which are not illustrated in the accompanying drawings and are well known in the art of beverage preparation machines. For example, the beverage preparation machine may comprise either a facility for storing an aqueous medium, such as an internal reservoir, or
10 a facility for connection to an external supply of aqueous medium, such as mains water. The aqueous medium will typically be water. A pump or equivalent may be provided for supplying the aqueous medium in a pressurised state to the capsule 1. The aqueous medium will typically be supplied at
15 a pressure of up to 9 to 14 bar. A heater may be provided for heating the aqueous medium to a desired temperature. The heater may heat the aqueous medium in the reservoir (where present) or may heat the aqueous medium on-demand as it passes through a conduit or over a thermoblock to the
20 receptacle 3. The beverage preparation machine may comprise base piercing means for piercing the base 42 of the capsule 1 to permit the aqueous medium to enter the capsule 1 and interact with the beverage ingredients therein. Alternatively, the capsule 1 may be provided with one or
25 more pre-formed openings to allow entry of the aqueous medium from the receptacle 3 into the capsule 1.

The enclosing member 2 may be of the type described in EP 1700548 comprising an annular element 22 having a leading edge 23 in the form of an annular rim, an inner face 25
30 facing the receptacle 3 and an outer face 24 facing an exterior. The leading edge 23 may be provided with a plurality of grooves as taught in EP 1700548. An upper end

(not shown) of the enclosing member 2 may be coupled to a supply of the aqueous medium and may provide a mounting for one or more perforation elements intended to pierce the base 42 of the capsule 1 in use.

5 The capsule holder 20 may be of the type described in EP 1700548 comprising relief elements 21 which are designed to tear and perforate the lid 41 of the capsule 1. The tearing of the lid 41 may occur due to internal
10 pressurisation of the capsule 1 caused by inflowing aqueous medium. The relief elements 21 may have any protruding shape able to cause a partial tearing of the foil member, e.g. pyramids, needles, bumps, cylinders, or elongated ribs.

 As shown in Figure 1, the cup-shaped body 40 and the lid 41 of the capsule 1 together enclose a beverage
15 ingredient chamber 50 which may be filled with a beverage ingredient or mixture of beverage ingredients. As a non-limiting example, the beverage ingredient may comprise roasted ground coffee.

 In the illustrated example, the cup-shaped body 40 is
20 made from aluminium or an aluminium alloy. However, other materials may be utilised, such as a laminate of aluminium or aluminium alloy and a polymer. The cup-shaped body 40 includes the base 42 and the side wall 43. There may be, as illustrated, a geometric discontinuity at the junction
25 between the base 42 and the side wall 43, for example, in the form of a shoulder 57. Alternatively, the base 42 and the side wall 43 may have a smooth geometric transition.

 The cup-shaped body 40 may have a thickness in the range of 80 to 500 microns. The thickness of the material
30 may be varied throughout the cup-shaped body 40. In the illustrated example the thickness is 100 microns.

2014266921 24 Feb 2017

The side wall 43 is provided with an annular trough 60 which is dimensioned to receive, partially or wholly, the leading edge 23 of the enclosing member 2 on movement of the enclosing member 2 into the closed position. A first side wall section 61 is provided extending between the base 42 and the annular trough 60 and a second side wall section 62 is provided extending between the annular trough 60 and a distal end of the side wall 43 of the capsule 1.

The annular trough 60 may be defined by an inner wall 65, an outer wall 66 and a floor 64 which extends there between. The inner wall 65 and outer wall 66 may, prior to insertion of the capsule 1 in the beverage preparation machine, extend perpendicularly to the floor 64. The inner wall 65 may be formed by a portion of the first side wall section 61.

A ridge zone 63 is located radially outwards of the annular trough 60. The ridge zone 63 may comprise an annular projection which extends back in the general direction of the base 42 such that an apex 67 of the ridge zone 63 is raised above the level of the floor 64 of the annular trough 60. The apex 67 may be raised above the floor 64 by a distance from 0.75 to 2.5 mm. As illustrated in this embodiment, the distance is 0.9 mm. The ridge zone 63 may be formed to have an inner wall provided by the outer wall 66 of the annular trough 60 and an outer wall 68 formed by at least a portion of the second side wall section 62.

The side wall 43, including the annular trough 60 and the ridge zone 63 may be formed integrally. Further, the cup-shaped body 40 including the side wall 43 and the base 42 may be formed integrally.

The annular trough 60 may have an internal width of from 1.3 to 2.0 mm. Typically, the internal width of the

annular trough 60 is chosen to be marginally greater than the breadth of the leading edge 23 of the annular element 22. In one example, the annular trough 60 has an internal width of approximately 1.5 mm to 1.8 mm.

5 The annular trough 60 may have an internal diameter of from 27.5 to 30.0 mm (that is the diameter of the surface of the inner wall 65 facing into the annular trough 60) and an outer diameter of from 29.3 to 32.5 mm (that is the diameter of the surface of the outer wall 66 facing into the annular
10 trough 60). Optionally, the internal diameter may be chosen so there is a slight interference fit between the inner wall 65 and the outer face 24 of the enclosing member 2 on closure. This helps to ensure good alignment of the annular trough 60 with the enclosing member 2.

15 As illustrated, the lid 41 is sealed to the annular trough 60. In particular, the lid 41 is sealed to an inner surface of the floor 64 of the annular trough 60. The floor 64 of the annular trough 60 is raised relative to a distal end of the side wall 43. Consequently, the lid 41 is also
20 raised relative to the distal end of the side wall 43. The floor 64 may be offset from the distal end of the side wall 43 by a distance from 0.1 to 2.0 mm as described previously. As illustrated, the offset is 1.85 mm. Sealing the lid 41 to the floor 64 helps to ensure that the enclosing member 2
25 does not bear down on a hollow part of the capsule 1 so as to trap beverage ingredients in between the leading edge 23 and the capsule holder 20 which could have a detrimental effect on the fluid-tightness of the seal.

 The lid 41 may be formed from aluminium, an aluminium
30 alloy or a laminate containing aluminium.

 The first side wall section 61 may comprise a frustoconical section 44 proximate the base 42 and a

2014266921 24 Feb 2017

cylindrical section 45 distal the base 42, wherein a portion of the cylindrical section 45 forms the inner wall 65 of the annular trough 60.

5 The capsule 1 may be provided with a rim 47 formed at an end of the cup-shaped body 40 remote from the base 42, i.e. at the distal end of the side wall 43. The rim 47 may be formed integrally with the cup-shaped body 40. In the illustrated example, the rim 47 is formed by a rolled-over portion 48 of the side wall 43.

10 In use of the beverage preparation system the enclosing member 2 is first moved into the open position and the capsule 1 is inserted into a location in between the capsule holder 20 and the enclosing member 2. Depending on the design of the beverage preparation machine, the capsule 1
15 may be inserted by gravity or by manual placement or a combination thereof. In addition, the initial insertion may place the capsule 1 in proximity to the enclosing member 2 such that subsequent movement of the enclosing member 2 carries the capsule 1 therewith into engagement with the
20 capsule holder 20. Alternatively, initial insertion may place the capsule 1 in proximity to the capsule holder 20 such that the capsule 1 remains substantially stationary during closure of the enclosing member 2.

25 The enclosing member 2 is then closed so as to sealingly engage the enclosing member 2 with the capsule 1. During this step the base 42 of the capsule 1 may be pierced by the perforation elements of the enclosing member 2.

30 Pressurised aqueous medium (which may be heated, at ambient temperature or chilled) is then flowed into the capsule 1 to produce a beverage from interaction with the beverage ingredients. During this step internal pressurisation of the beverage ingredient chamber 50 causes

2014266921 24 Feb 2017

the lid 41 to be deformed outwardly against the relief elements 21 of the capsule holder 20 resulting in at least partial tearing of the lid 41 which opens up an exit path from the capsule 1 for the beverage.

5 The beverage is then output for consumption.

 As shown in Figures 5 and 6, during the step of closing the enclosing member 2 relative to the capsule holder 20 the side wall 43 of the capsule 1 is contacted by the enclosing member 2 to deform the side wall 43. In particular, the
10 leading edge 23 enters the annular trough 60 and bears on the floor 64 and/or the inner wall 65 and/or the outer wall 66. The floor 64 is driven downwards by the action of the enclosing member 2 to nip the floor 64 (and the lid 41 sealed to the floor 64) against the capsule holder 20. The
15 leading edge 23 may also act to pinch the material of the side wall 43 during this movement which consequently causes the ridge zone 63 to be pivoted inwards to bring the apex 67 of the ridge zone 63 and/or the outer wall 66 of the annular trough 60 into sealing engagement with the outer face 24 of
20 the annular element 22 as shown in Figure 6. Importantly, the initial point of contact between the leading edge 23 and the floor 64 is axially spaced from the capsule holder 20 such that there is room for the side wall 43 to deform downwards towards the capsule holder 20 enough to allow for
25 inward pivoting of the ridge zone 63 before the side wall 43 is nipped against the capsule holder 20.

 The induced movement of the side wall 43 causes the side wall 43 to undergo plastic deformation. In particular, as the side wall 43 is deformed downwards, the side wall 43
30 (in particular portions of the annular trough 60) may be plastically drawn over the leading edge 23 of the enclosing member 2 which encourages the material of the side wall 43

2014266921 24 Feb 2017

to be closely conformed to the grooves of the leading edge 23. Thus, the annular trough 60 may form a sealing interface with the leading edge 23 of the enclosing member 2.

Further, deformation of the annular trough 60 may also
5 cause an outward pressure to be exerted by the side wall 43 on the inner face 25 of the enclosing member 2 to form a further sealing interface.

Figures 7 to 12 illustrate a second embodiment of capsule 1. Features corresponding to those of the first
10 embodiment are denoted by corresponding reference signs. Features of the first embodiment and this embodiment may be interchanged and combined as desired. In addition, in the following description only differences between the
15 embodiments will be described in detail. In other respects the reader is directed to the description of the prior embodiment.

The cup-shaped body 40 differs from that of the first embodiment in the configuration and geometry of the annular trough 60. As in the first embodiment, the annular trough 60
20 is dimensioned to receive, partially or wholly, the leading edge 23 of the enclosing member 2 on movement of the enclosing member 2 into the closed position. The inner wall 65 of the annular trough 60, as before, is substantially perpendicular to the floor 64. However, in contrast, the
25 outer wall 66 is angled relative to the floor 64, such that an internal angle α at a junction between the floor 64 and the outer wall 66 is from 90° to 120° , preferably 105° .

The ridge zone 63 is again located radially outwards of the annular trough 60 and comprises an annular projection
30 which extends back in the general direction of the base 42 such that an apex 67 of the ridge zone 63 is raised above the level of the floor 64 of the annular trough 60. The apex

67 may be raised above the floor 64 by a distance from 0.75 to 2.5 mm. As illustrated in this embodiment, the distance is 2.2 mm. The ridge zone 63 may be formed to have an inner wall provided by the angled outer wall 66 of the annular
5 trough 60 and an outer wall 68 formed by at least a portion of the second side wall section 62. As shown most clearly in Figure 8, the second side wall section 62 may comprise between the outer wall 68 and the rolled-over portion 48 of the rim 47 an additional annular ridge 70 which may provide
10 additional stiffness to the outer portion of the flange. The height of the additional annular ridge 70 may be 0.7 to 0.8 mm.

The side wall 43, including the annular trough 60 and the ridge zone 63 may be formed integrally. Further, the
15 cup-shaped body 40 including the side wall 43 and the base 42 may be formed integrally.

The annular trough 60 may have an internal width of from 1.3 to 2.0 mm. As illustrated, the annular trough 60 has an internal width of approximately 1.5 mm to 1.8 mm.

20 As illustrated, the lid 41 is sealed to the annular trough 60. In particular, the lid 41 is sealed to an inner surface of the floor 64 of the annular trough 60. The floor 64 of the annular trough 60 is substantially level with a distal end of the side wall 43 prior to insertion. As
25 illustrated the offset from the distal end of the side wall 43 and the lid is only 0.2 mm.

In use of the beverage preparation system, as shown in Figures 9 to 12, as before the enclosing member 2 is first moved into the open position and the capsule 1 is inserted
30 into a location in between the capsule holder 20 and the enclosing member 2. Figure 9 illustrates that the leading edge 23 of the enclosing member 2 may comprise an inner rim

23a and an outer rim 23b which are concentric and spaced apart from one another to define a recess 23c there between, which may be generally annular (although may have interruptions around its circumference).

5 As shown in Figures 11 and 12, on closing the enclosing member 2 relative to the capsule holder 20 the side wall 43 of the capsule 1 is contacted by the enclosing member 2 to deform the side wall 43. In particular, the inner rim 23a of the leading edge 23 is received in the annular trough 60 and
10 bears on the outer wall 66 while at the same time (or shortly thereafter) the apex 67 of the ridge zone 63 is received in the recess 23c. The ridge zone 63 (and floor 64) is driven downwards by the action of the enclosing member 2 on the outer wall 66 and/or apex 67 causing the outer wall
15 66 of the annular trough 60 and the outer wall 68 of the ridge zone 63 to buckle and deform/crumple. During this movement the material of the outer wall 66 of the annular trough 60 may be plastically drawn over the leading edge 23 to conform the outer wall 66 of the annular trough 60 to the
20 grooves or indentations to provide an effective seal.

The downward movement of the ridge zone 63 also nips the floor 64 (and the lid 41 sealed to the floor 64) against the capsule holder 20 as shown in Figure 12.

25 The geometry of the outer wall 68 of the ridge zone 63, with the additional annular ridge 70 helps to stiffen the distal end of the side wall 43 and prevent the rim 47 being deflected down into contact with the capsule holder 20.

30 Downward movement of the enclosing member 2 may continue beyond the point illustrated in Figure 12 until the inner rim 23a contacts and bears against the floor 64 of the annular trough 60.

Piercing and brewing of a beverage from the capsule 1 may be as described above in the first embodiment.

Figures 13 to 18 illustrate a third embodiment of capsule 1. Features corresponding to those of the first and/or second embodiment are denoted by corresponding reference signs. Features of the first and/or second embodiment and this embodiment may be interchanged and combined as desired. In addition, in the following description only differences between the embodiments will be described in detail. In other respects the reader is directed to the description of the prior embodiments.

The cup-shaped body 40 differs from that of the first and second embodiments in the configuration and geometry of the annular trough 60. As in the second embodiment, the annular trough 60 is dimensioned to receive, partially or wholly, the leading edge 23 of the enclosing member 2 on movement of the enclosing member 2 into the closed position. The inner wall 65 of the annular trough 60 is substantially perpendicular to the floor 64 and the outer wall 66 is angled relative to the floor 64, such that an internal angle α at a junction between the floor 64 and the outer wall 66 is from 90° to 120° , preferably 105° .

The ridge zone 63 is again located radially outwards of the annular trough 60 and comprises an annular projection which extends back in the general direction of the base 42 such that an apex 67 of the ridge zone 63 is raised above the level of the floor 64 of the annular trough 60. The apex 67 is somewhat more rounded than in the second embodiment. The apex 67 may be raised above the floor 64 by a distance from 0.75 to 2.5 mm. As illustrated in this embodiment, the distance is 2.2 mm. The ridge zone 63 may be formed to have an inner wall provided by the angled outer wall 66 of the

annular trough 60 and an outer wall 68 formed by at least a portion of the second side wall section 62. As shown most clearly in Figure 14, the outer wall 68 comprises three distinct sections - an upper section 73 which, prior to
5 insertion, is perpendicular to the floor 64, a mid-section 71 that is angled at an angle β of from 20 to 80°, preferably 60°, to the vertical and a lower section 72 that includes a horizontal portion - parallel to the floor 64 - before merging into the rolled-over portion 48 of the rim
10 47.

The side wall 43, including the annular trough 60 and the ridge zone 63 may be formed integrally. Further, the cup-shaped body 40 including the side wall 43 and the base 42 may be formed integrally.

15 The annular trough 60 may have an internal width of from 1.3 to 2.0 mm. As illustrated, the annular trough 60 has an internal width of approximately 1.5 mm to 1.8 mm.

As illustrated, the lid 41 is sealed to the annular trough 60. In particular, the lid 41 is sealed to an inner
20 surface of the floor 64 of the annular trough 60. The floor 64 of the annular trough 60 is substantially level with a distal end of the side wall 43 prior to insertion. As illustrated the offset from the distal end of the side wall 43 and the lid is only 0.2 mm.

25 In use of the beverage preparation system, as shown in Figures 15 to 18, as before the enclosing member 2 is first moved into the open position and the capsule 1 is inserted into a location in between the capsule holder 20 and the enclosing member 2.

30 As shown in Figures 17 and 18, on closing the enclosing member 2 relative to the capsule holder 20 the side wall 43 of the capsule 1 is contacted by the enclosing member 2 to

deform the side wall 43. In particular, the inner rim 23a of the leading edge 23 is received in the annular trough 60 and bears on the outer wall 66 while at the same time (or shortly thereafter) the apex 67 of the ridge zone 63 is
5 received in the recess 23c. The ridge zone 63 (and floor 64) is driven downwards by the action of the enclosing member 2 on the outer wall 66 and/or apex 67 causing the outer wall 66 of the annular trough 60 and the outer wall 68 of the ridge zone 63 to buckle and deform/crumple. During this
10 movement the material of the outer wall 66 of the annular trough 60 may be plastically drawn over the leading edge 23 to conform the outer wall 66 of the annular trough 60 to the grooves or indentations to provide an effective seal.

The downward movement of the ridge zone 63 also nips
15 the floor 64 (and the lid 41 sealed to the floor 64) against the capsule holder 20 as shown in Figure 12.

The geometry of the outer wall 68 of the ridge zone 63, with the upper section 73, mid-section 71 and lower section 72 helps to stiffen the distal end of the side wall 43 and
20 prevent the rim 47 being deflected down into contact with the capsule holder 20.

Downward movement of the enclosing member 2 may continue beyond the point illustrated in Figure 12 until the inner rim 23a contacts and bears against the floor 64 of the
25 annular trough 60.

Piercing and brewing of a beverage from the capsule 1 may be as described above in the first embodiment.

The capsule 1 of any of the above embodiments may comprise a side wall 43 formed from a laminate material as
30 discussed above having a polymer layer. Closure of the enclosing member 2 may compress at least the polymer layer of the laminate material when forming any of the sealing

interfaces mentioned above. The compression of the polymer layer may aid the conforming of the side wall 43 to the shape of the leading edge 23. In particular the polymer layer may aid filling of any gaps arising due to the presence of grooves in the leading edge 23. Preferably, the polymer layer is directed outwardly to be directly contacted by the leading edge 23. The cup-shaped body 40 may comprise a unitary piece of laminate material.

The laminate, where used, may comprise a ductile structural layer formed from a material such as aluminium or an aluminium alloy together with a resilient layer formed from a polymer. The laminate may comprise only a single layer of aluminium or aluminium alloy together with a single layer of polymer together with one or more optional lacquer layers, tie layers or adhesive layers applied to the aluminium or aluminium alloy.

The polymer layer may, for example, comprise a material selected from the group of: polyvinyl chloride (PVC), polypropylene (PP), low density polyethylene (LDPE), medium density polyethylene (MDPE), high density polyethylene (HDPE), fluorinated ethylene propylene (FEP), polytetrafluoroethylene (PTFE), polyethylene terephthalate (PET), polyamide (PA), ethylene propylene diene monomer (EPDM), polychloroprene or isobutylene.

In addition, during use the hot water passed through the receptacle 3 may act to slightly soften the material of the polymer layer. Such softening may lead to further deformation of the side wall 43 under the compressive loading of the enclosing member 2. This effect may help to reinforce the fluid seal between the enclosing member 2 and the capsule 1 by tending to seal up any gaps having hot water leaking there through.

The deformation of the side wall 43 will also typically cause a reduction in the longitudinal height of the capsule 1 relative to its height prior to insertion.

It is to be understood that, if any prior art is referred to herein, such reference does not constitute an admission that such prior art forms a part of the common general knowledge in the art, in Australia or any other country.

In the claims that follow and in the preceding description of the invention, except where the context requires otherwise due to express language or necessary implication, the word "comprise" or variations such as "comprises" or "comprising" is used in an inclusive sense, i.e. to specify the presence of the stated features but not to preclude the presence or addition of further features in various embodiments of the invention

.

Claims:

1. A beverage producing system comprising:
a capsule containing beverage ingredients; and
a beverage preparation machine;
the capsule comprising a cup-shaped body and a lid; the cup-shaped body having a base and a side wall and the lid being sealed to the cup-shaped body;

the capsule being designed for insertion into the beverage preparation machine to permit a pressurised liquid to be flowed through the capsule in order to produce a beverage from interaction with the beverage ingredients;

the beverage preparation machine having an enclosing member adapted to be selectively movable between an open position to permit insertion of the capsule into the beverage preparation machine and a closed position in which the enclosing member sealingly engages the capsule;

wherein, prior to insertion, the side wall comprises:

- an annular trough being dimensioned to receive the enclosing member on movement of the enclosing member into the closed position;

- a first side wall section extending between the base and the annular trough; and

- a second side wall section extending between the annular trough and a rim of the capsule;

wherein the cup-shaped body is formed from aluminium, an aluminium alloy or a laminate comprising at least one layer formed from aluminium or an aluminium alloy

wherein the first side wall section, the second side wall section and the annular trough are formed integrally; and

wherein the annular trough is adapted to form a sealing interface with a leading edge of the enclosing member, and the side wall is adapted such that during closure of the enclosing member the side wall is plastically drawn over the leading edge of the enclosing member.

2. A beverage producing system as claimed in claim 1, wherein the second side wall section defines a ridge zone located radially outwards of the annular trough.

3. A beverage producing system as claimed in claim 1 or claim 2, wherein the side wall is adapted to undergo plastic deformation during closure of the enclosing member.

4. A beverage producing system as claimed in any one of the preceding claims, wherein the side wall is adapted such that, in use, closure of the enclosing member deforms the side wall to cause the second side wall section to be forced inwardly against an outer face of the enclosing member to form a sealing interface with the outer face of the enclosing member.

5. A beverage producing system as claimed in any one of the preceding claims, wherein, prior to insertion, the annular trough comprises an inner wall, an outer wall and a floor; and optionally on closure of the enclosing member a leading edge of the enclosing member contacts the outer wall of the annular trough and forms a seal therewith.

6. A beverage producing system as claimed in claim 5, wherein the inner wall and outer wall are substantially perpendicular to the floor or the outer wall is angled relative to the floor, such that an internal angle at a junction between the floor and the outer wall is from 90°

to 120°, preferably 105°.

7. A beverage producing system as claimed in any one of claims 3 to 6, as dependent on claim 2, wherein the ridge zone comprises an apex, and a leading edge of the enclosing member comprises an inner rim and an outer rim and a recess located between the inner rim and the outer rim, wherein on closure of the enclosing member the apex of the ridge zone is received in the recess between the inner rim and the outer rim.

8. A beverage producing system as claimed in any one of the preceding claims, wherein the annular trough is adapted to be nipped against a capsule holder of the beverage preparation machine part.

9. A beverage producing system as claimed in any one of the preceding claims, wherein, prior to insertion, a floor of the annular trough is raised relative to the rim; and optionally the side wall is adapted such that, in use, closure of the enclosing member deforms the side wall to cause the floor of the annular trough to be brought substantially into alignment with the rim.

10. A beverage producing system as claimed in any one of the preceding claims, wherein, prior to insertion, the side wall comprises a frustoconical section proximate the base.

11. A beverage producing system as claimed in any one of the preceding claims, wherein a leading edge of the enclosing member comprises a plurality of grooves or indentations, and the side wall is adapted such that the plastic deformation of the side wall conforms the annular trough of the side wall to the grooves or indentations to

provide an effective seal.

12. A beverage producing system as claimed in claim 11, wherein the plastic deformation of the side wall conforms the outer wall of the annular trough to the grooves or indentations to provide an effective seal.

13. A capsule for preparing a beverage comprising a cup-shaped body and a lid; the cup-shaped body having a base and a side wall and the lid being sealed to the cup-shaped body;

the capsule being designed for insertion into a beverage preparation machine to permit a pressurised liquid to be flowed through the capsule in order to produce a beverage from interaction with the beverage ingredients;

the beverage preparation machine being of the type having an enclosing member adapted to be selectively movable between an open position to permit insertion of the capsule into the beverage preparation machine and a closed position in which the enclosing member sealingly engages the capsule;

wherein the side wall comprises:

- an annular trough being dimensioned to receive the enclosing member;
- a first side wall section extending between the base and the annular trough; and
- a second side wall section extending between the annular trough and a rim of the capsule;

wherein the cup-shaped body is formed from aluminium, an aluminium alloy or a laminate comprising at least one layer formed from aluminium or an aluminium alloy;

wherein the first side wall section, the second side wall section and the annular trough are formed integrally; and

wherein the annular trough is adapted to form a sealing interface with a leading edge of the enclosing member and the side wall is adapted such that during closure of the enclosing member the side wall is plastically drawn over the leading edge of the enclosing member.

14. A capsule as claimed in claim 13, wherein the second side wall section defines a ridge zone located radially outwards of the annular trough.

15. A capsule as claimed in claim 13 or claim 14, wherein the side wall is adapted to undergo plastic deformation during closure of the enclosing member.

16. A capsule as claimed in any one of claims 15 to 17, wherein a floor of the annular trough is raised relative to the rim or is substantially level with the rim.

17. A capsule as claimed in any one of claims 13 to 16, wherein the side wall comprises a frustoconical section proximate the base.

18. A capsule as claimed in any one of claims 13 to 17, wherein the annular trough comprises an inner wall, an outer wall and a floor; and optionally the inner wall and outer wall are substantially perpendicular to the floor or the outer wall is angled relative to the floor, such that an internal angle at a junction between the floor and the outer wall is from 90° to 120°, preferably 105°.

19. A beverage producing system as claimed in any one of claims 1 to 12, or a capsule as claimed in any one of claims 13 to 18, wherein the rim is formed integrally with

the cup-shaped body and/or the rim is formed by a rolled-over portion of the side wall.

20. A beverage producing system as claimed in any one of claims 1 to 12, or a capsule as claimed in any one of claims 13 to 18, wherein the annular trough has an internal width of from 1.3 to 2.0 mm; and optionally has an internal width of approximately 1.5 mm to 1.8 mm.

21. A beverage producing system as claimed in any one of claims 1 to 12, or a capsule as claimed in any one of claims 13 to 18, wherein the annular trough has an internal diameter of from 27.5 to 30.0 mm and an outer diameter of from 29.3 to 32.5 mm.

22. A beverage producing system as claimed in any one of claims 1 to 12, or a capsule as claimed in any one of claims 13 to 18, wherein the lid is sealed to the annular trough of the side wall; and optionally the lid is sealed to an inner surface of a floor of the annular trough.

23. A capsule as claimed in any one of claims 13 to 18, wherein the laminate comprises at least an aluminium or aluminium alloy layer and a polymer layer; and optionally the cup-shaped body comprises a unitary piece of laminate material.

24. A capsule as claimed in claim 24, wherein the laminate material comprises only a single aluminium layer and a single polymer layer (with optionally one or more lacquer layers, tie layers or adhesive layers).

25. A capsule as claimed in claim 24 or claim 25, wherein the polymer layer comprises a material selected from the group of: polyvinyl chloride (PVC), polypropylene

(PP), low density polyethylene (LDPE), medium density polyethylene (MDPE), high density polyethylene (HDPE), fluorinated ethylene propylene (FEP), polytetrafluoroethylene (PTFE), polyethylene terephthalate (PET), polyamide (PA), ethylene propylene diene monomer (EPDM), polychloroprene or isobutylene.

26. A beverage producing system as claimed in any one of claims 1 to 12, or a capsule as claimed in any one of claims 13 to 18, wherein the lid is formed from aluminium, an aluminium alloy or a laminate comprising at least one layer formed from aluminium or an aluminium alloy.

27. A beverage producing system as claimed in any one of claims 1 to 12, or a capsule as claimed in any one of claims 13 to 18, wherein the cup-shaped body has a thickness in the range of 80 to 500 microns.

28. A method for preparing a beverage comprising the steps of:

- providing a capsule as claimed in any one of claims 13 to 18;
 - providing a beverage preparation machine having an enclosing member;
 - moving the enclosing member into an open position;
 - inserting the capsule into the beverage preparation machine;
 - closing the enclosing member so as to sealingly engage the enclosing member with the capsule;
 - flowing a pressurised liquid through the capsule to produce a beverage from interaction with the beverage ingredients; and
 - outputting the beverage for consumption;
- wherein on closure, the enclosing member engages

the annular trough of the side wall of the capsule to thereby deform the side wall;

wherein said deformation of the side wall causes the formation of at least one sealing interface between the enclosing member and the side wall.

29. The method of claim 28 wherein the side wall undergoes plastic deformation during closure of the engaging member.

30. The method of claim 28 or claim 29, wherein deformation of the annular trough forms a sealing interface with a leading edge of the enclosing member; and optionally the side wall is plastically drawn over the leading edge of the enclosing member.

31. The method of any one of claims 28 to 30, wherein the annular trough is nipped against a capsule holder of the beverage preparation machine part.

32. The method of any one of claims 28 to 31, wherein the second side wall section is forced inwardly against an outer face of the enclosing member to form a sealing interface with the outer face of the enclosing member.

33. The method of any one of claims 28 to 32, wherein on closure of the enclosing member a leading edge of the enclosing member contacts the outer wall of the annular trough and forms a seal therewith.

34. The method of any one of claims 28 to 33, wherein the ridge zone comprises an apex, and a leading edge of the enclosing member comprises an inner rim and an outer rim and a recess located between the inner rim and the outer rim, wherein on closure of the enclosing member the

apex of the ridge zone is received in the recess between the inner rim and the outer rim.

35. The method of any one of claims 28 to 34, wherein a leading edge of the enclosing member comprises a plurality of grooves or indentations, and the side wall is plastically deformed to conform the side wall to the grooves or indentations to provide an effective seal.

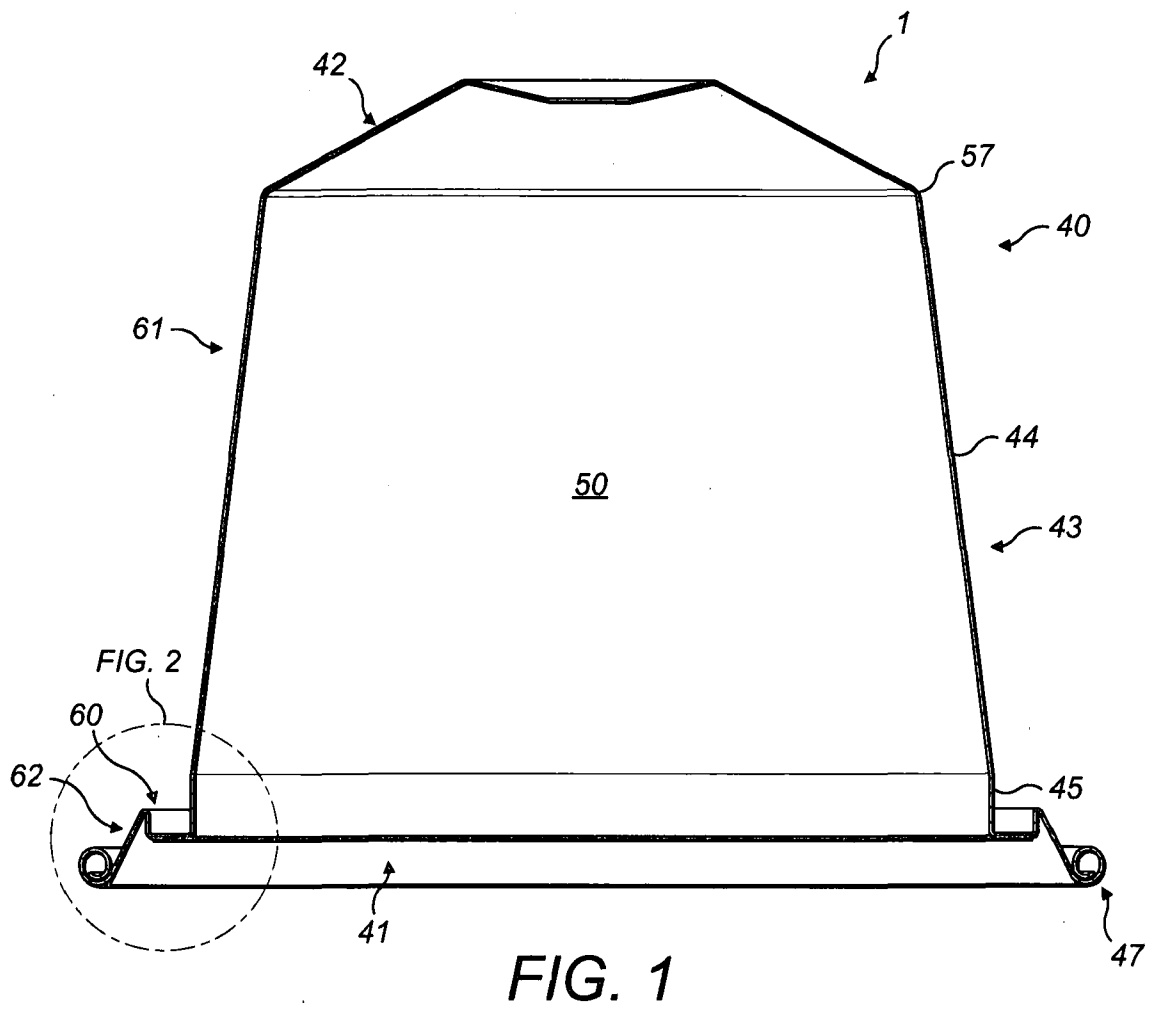

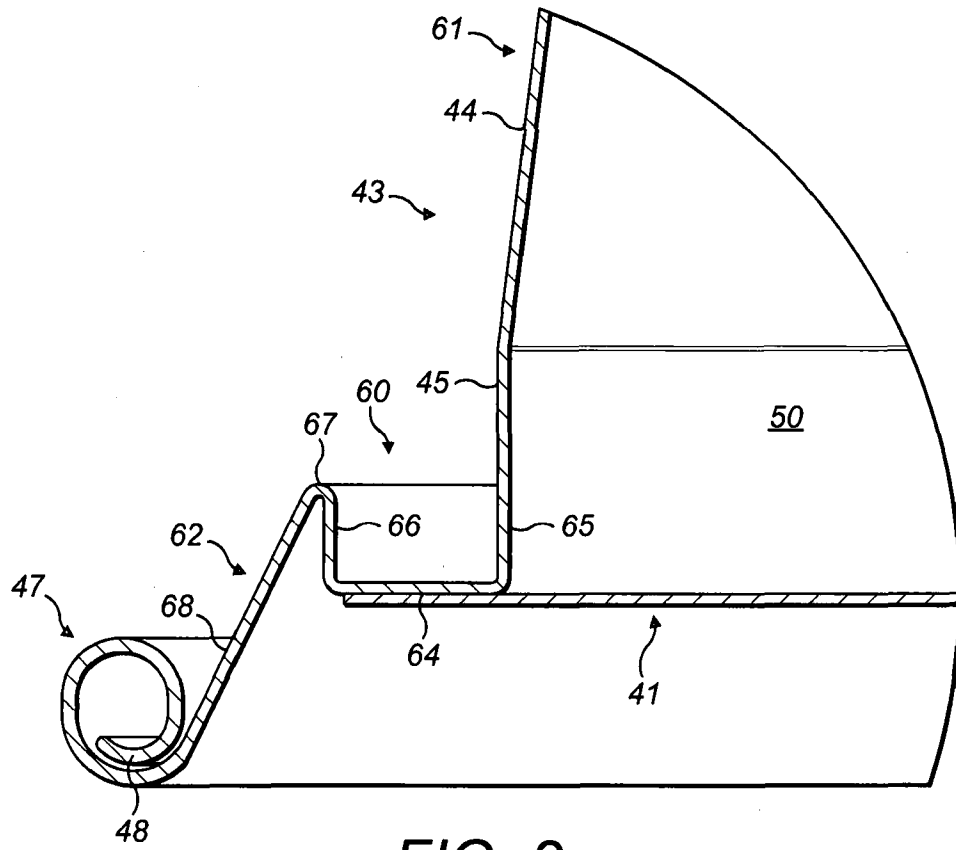

FIG. 2

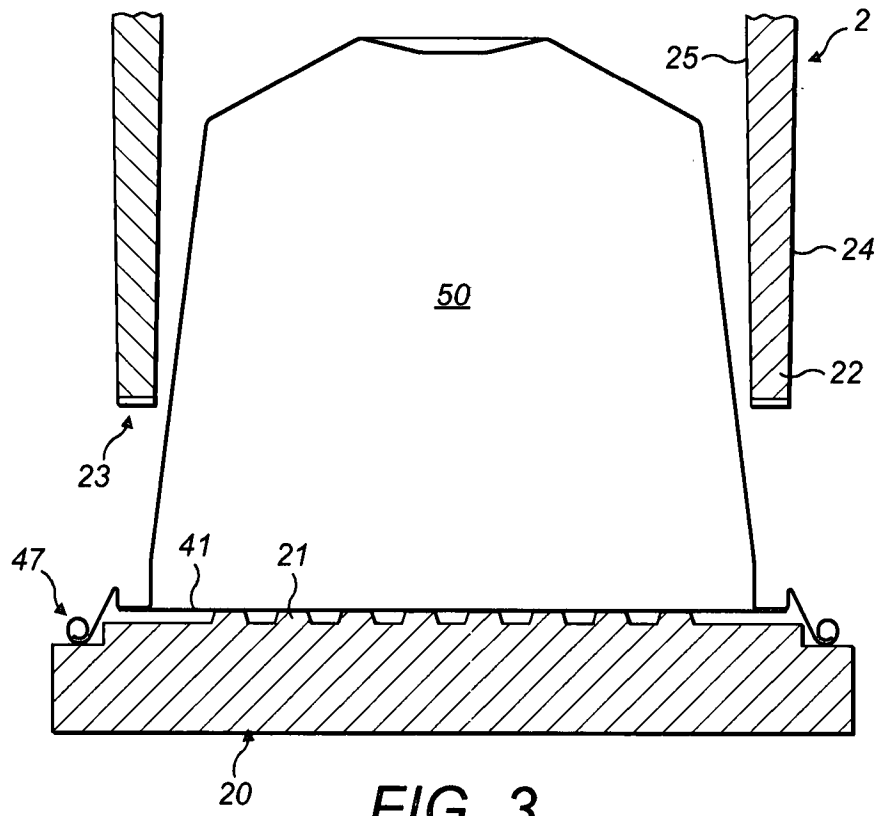

FIG. 3

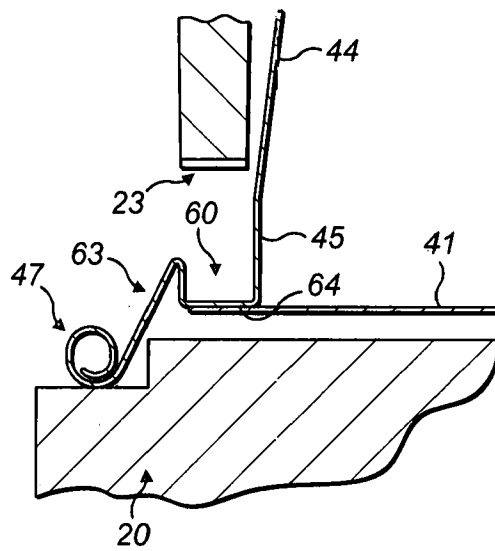

FIG. 4

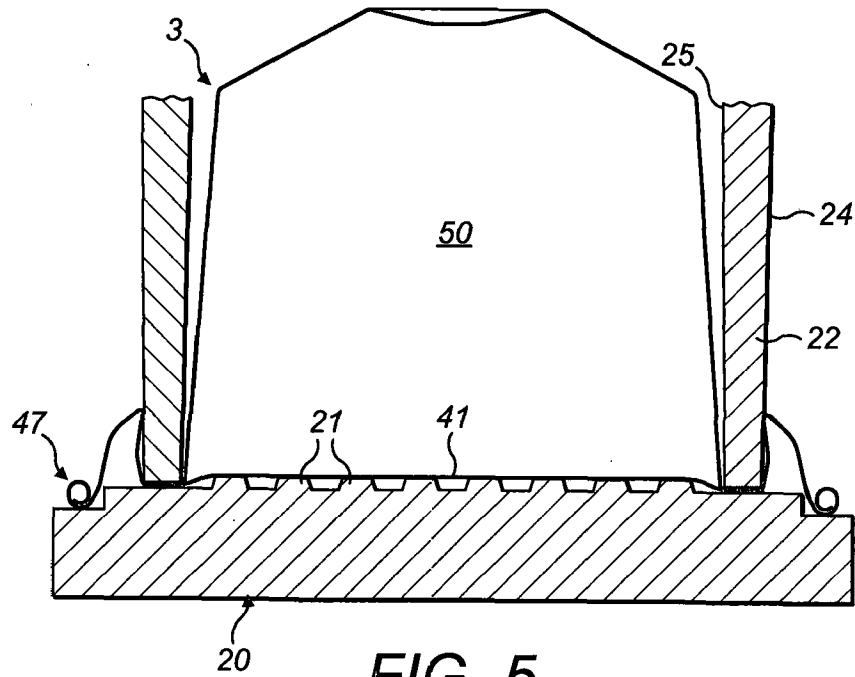

FIG. 5

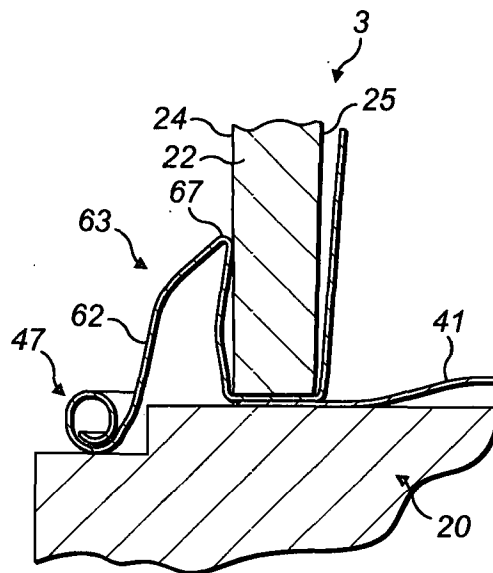

FIG. 6

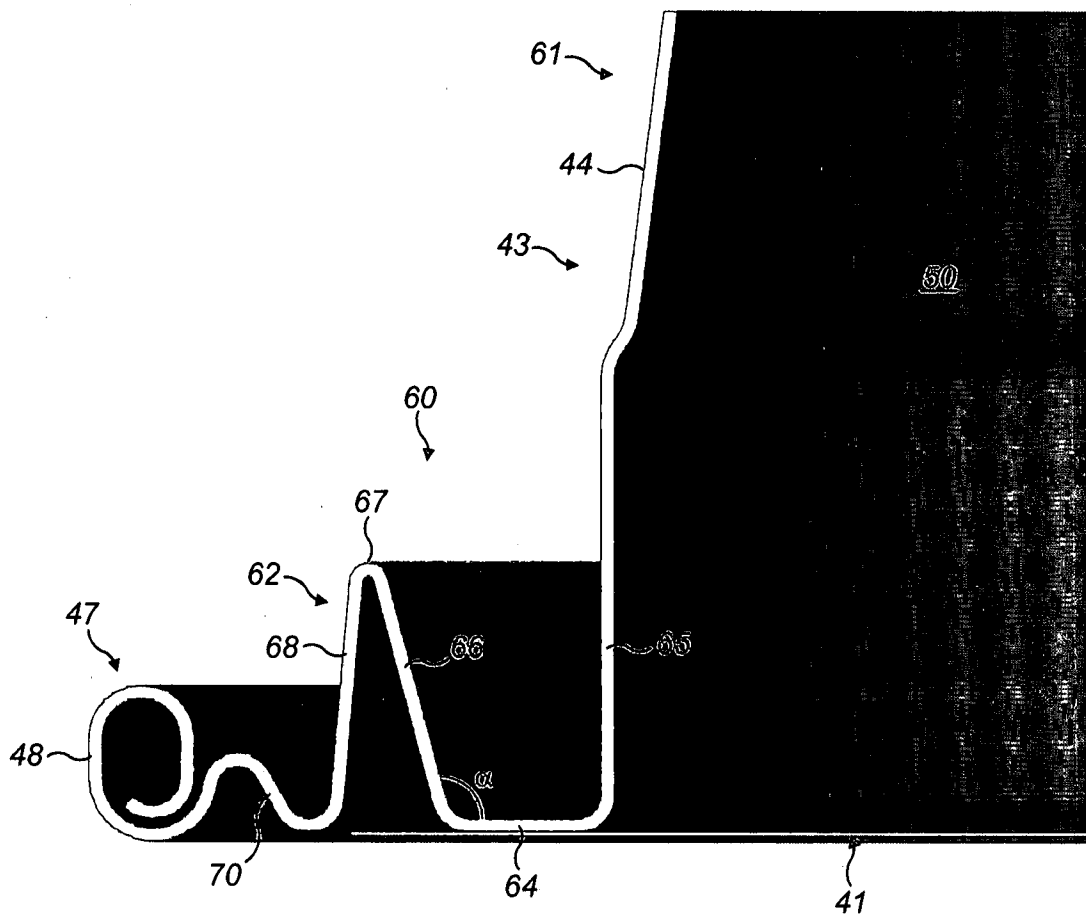

FIG. 8

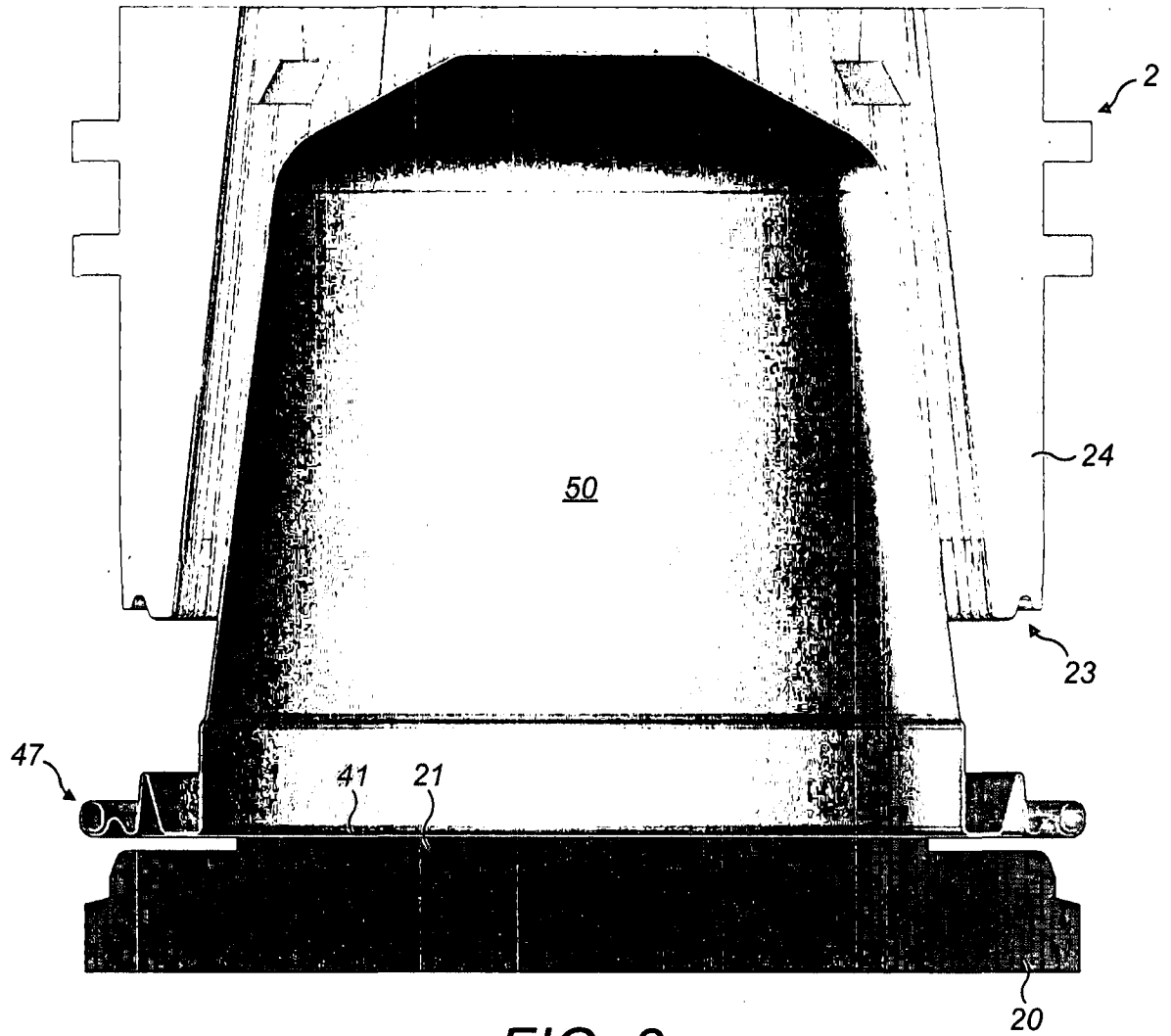

FIG. 9

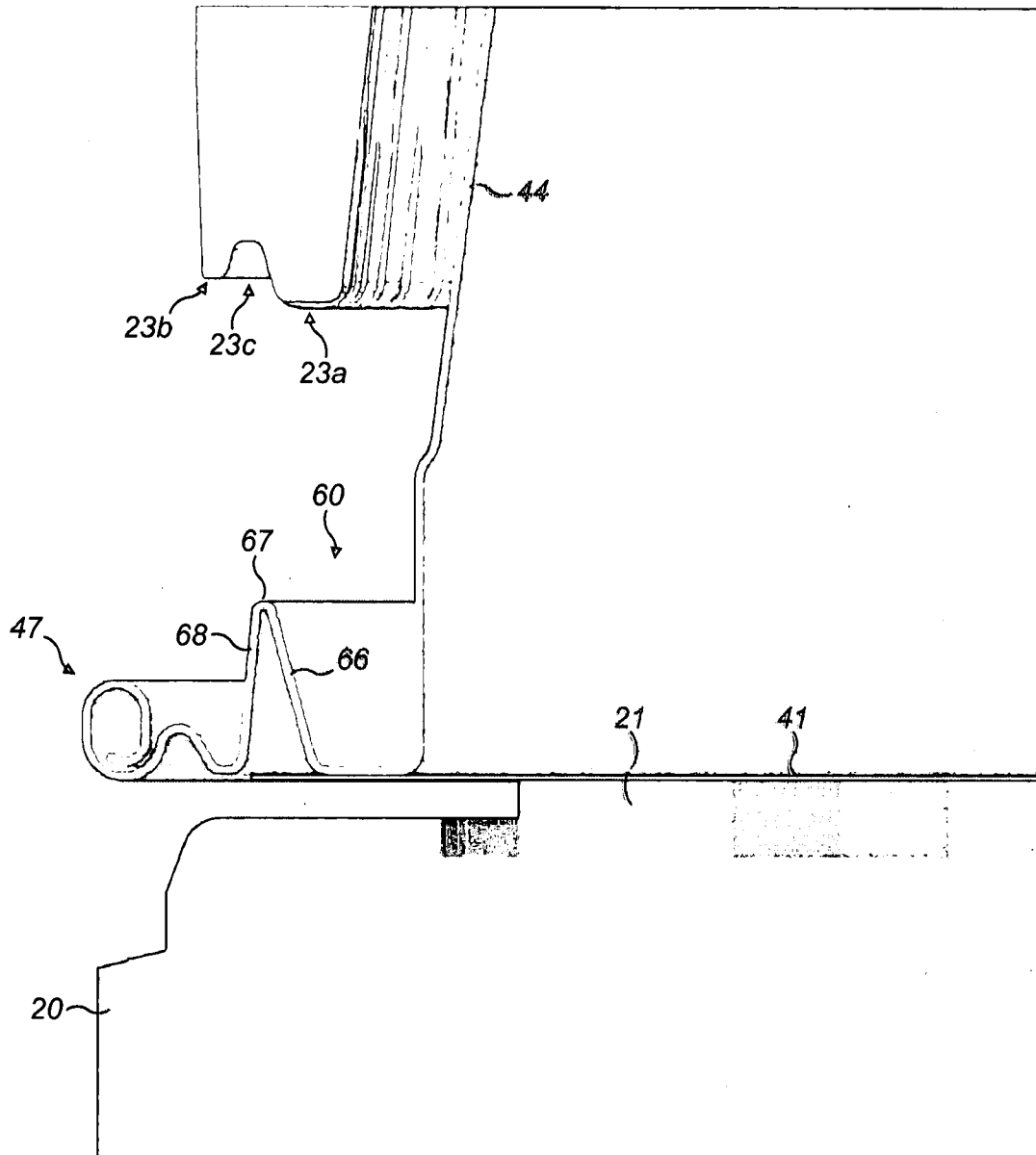

FIG. 10

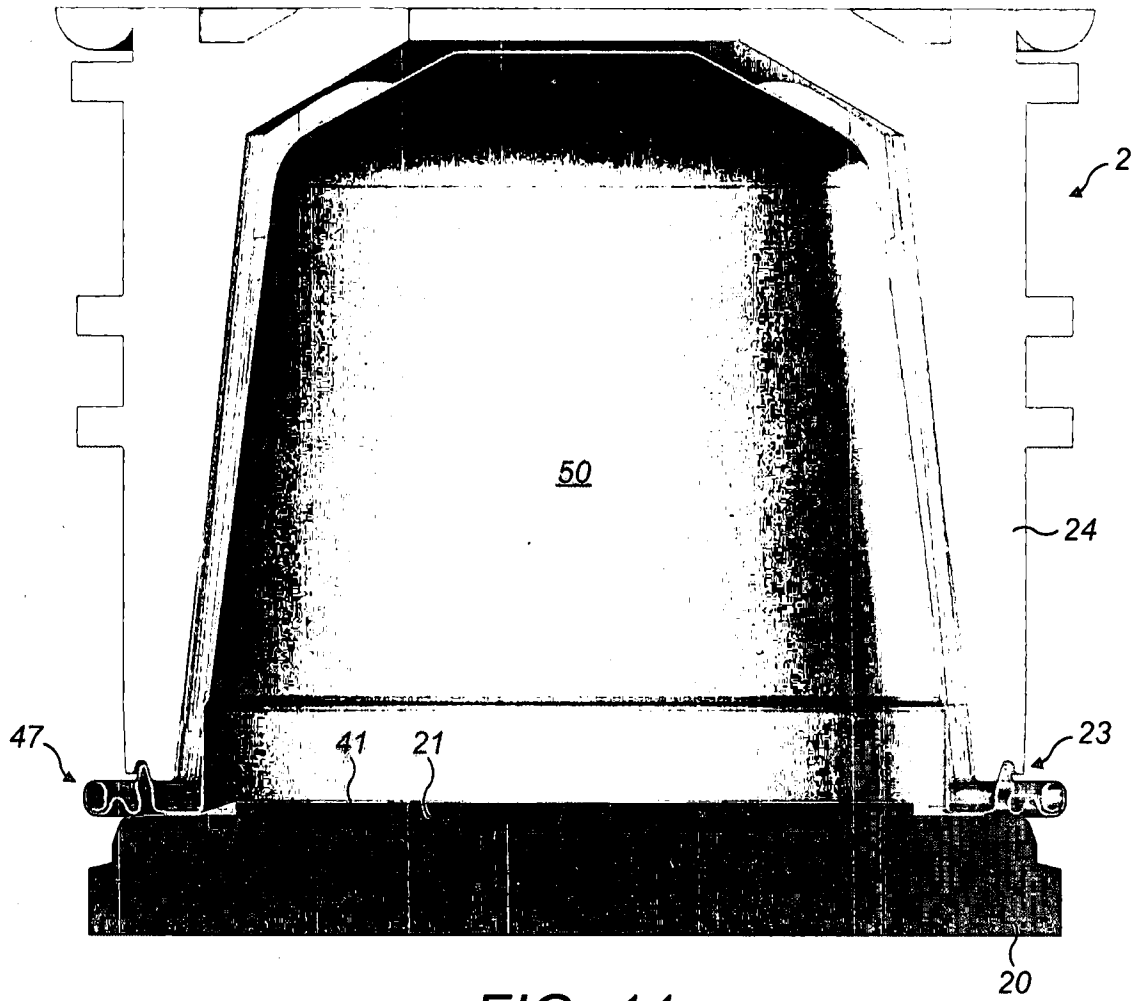

FIG. 11

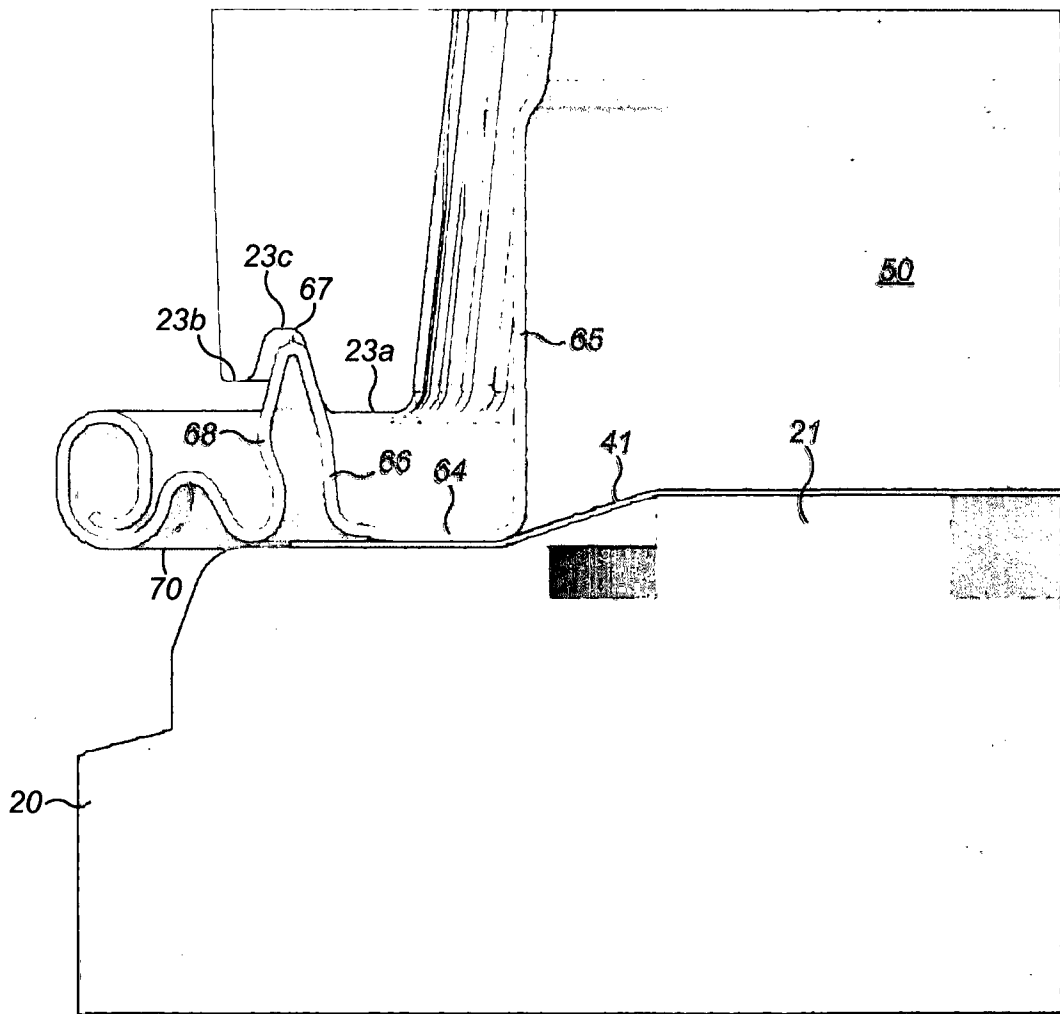

FIG. 12

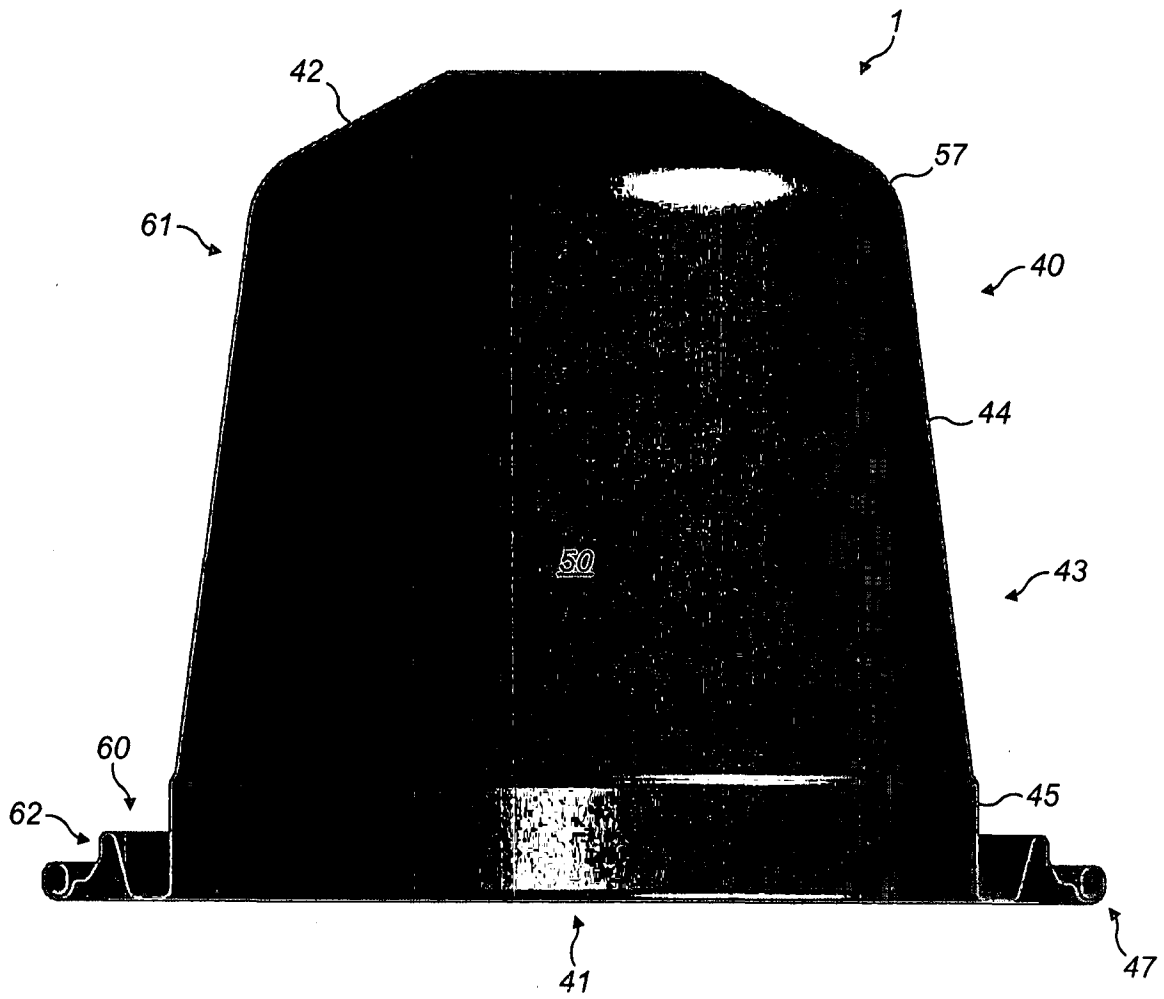

FIG. 13

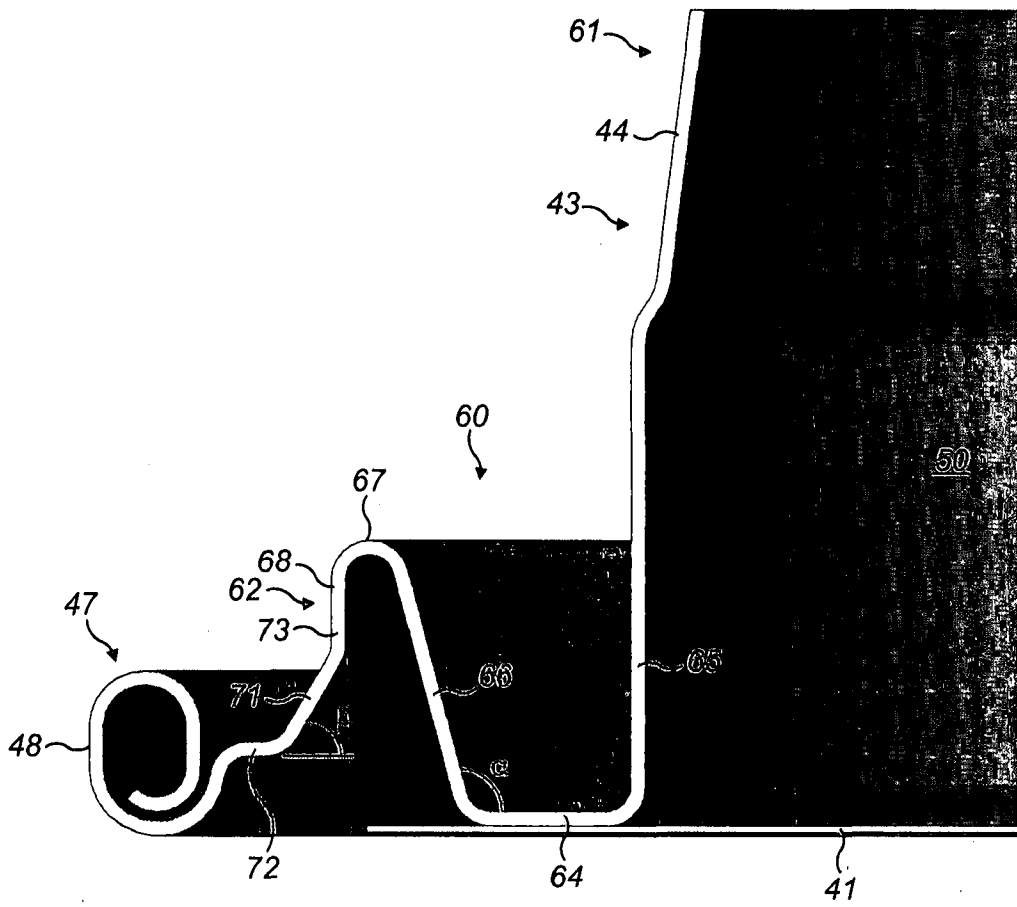

FIG. 14

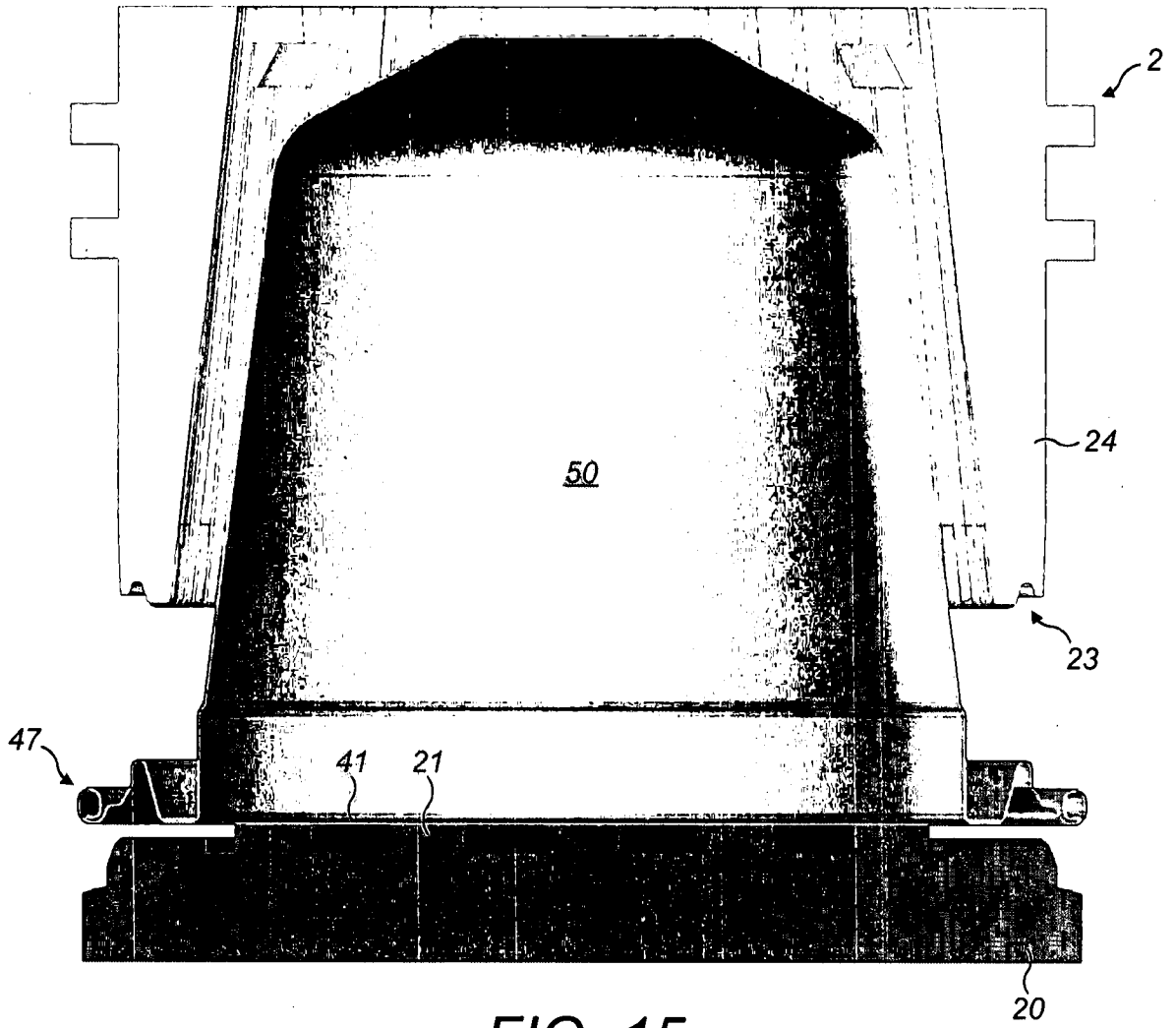

FIG. 15

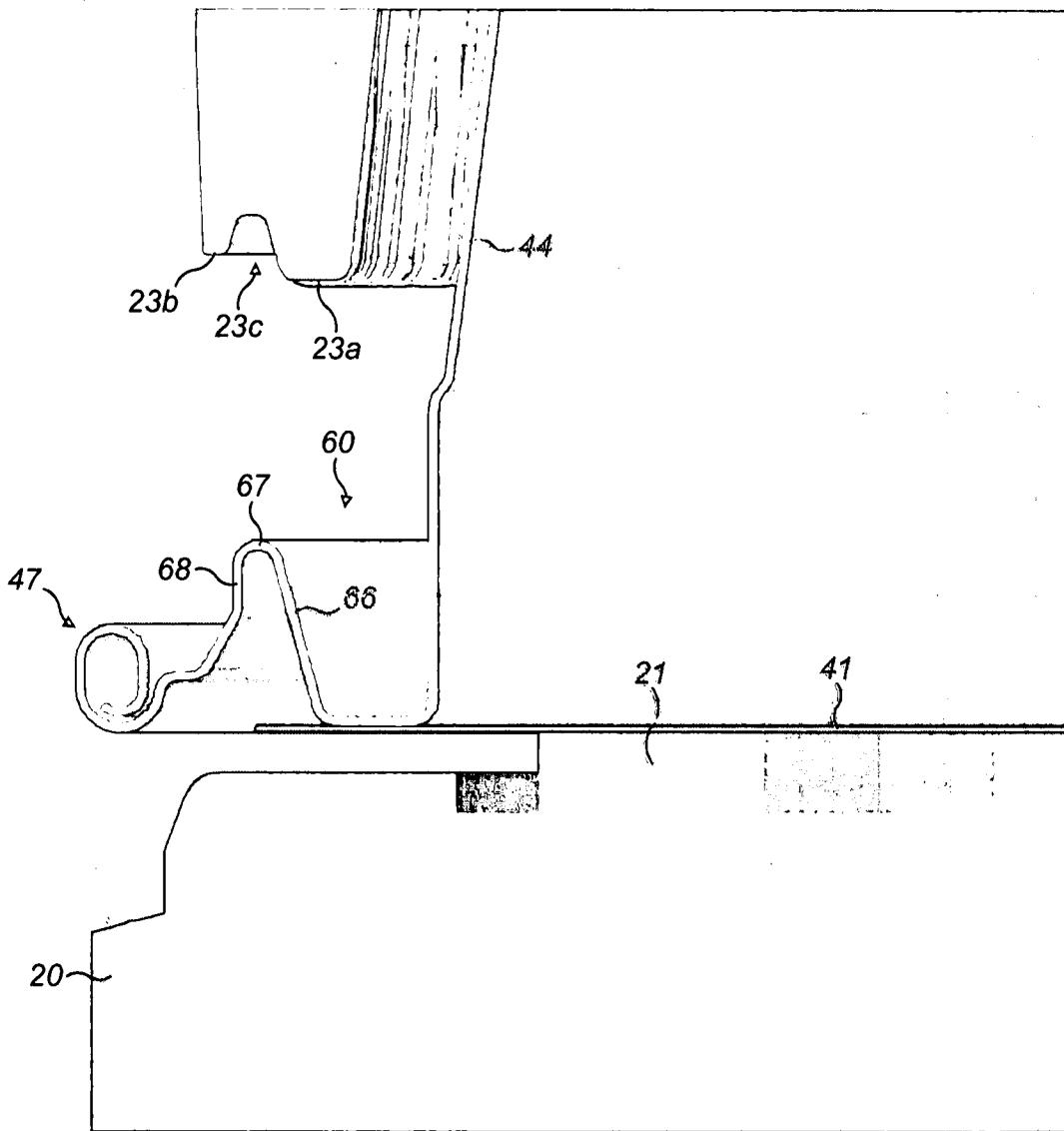

FIG. 16

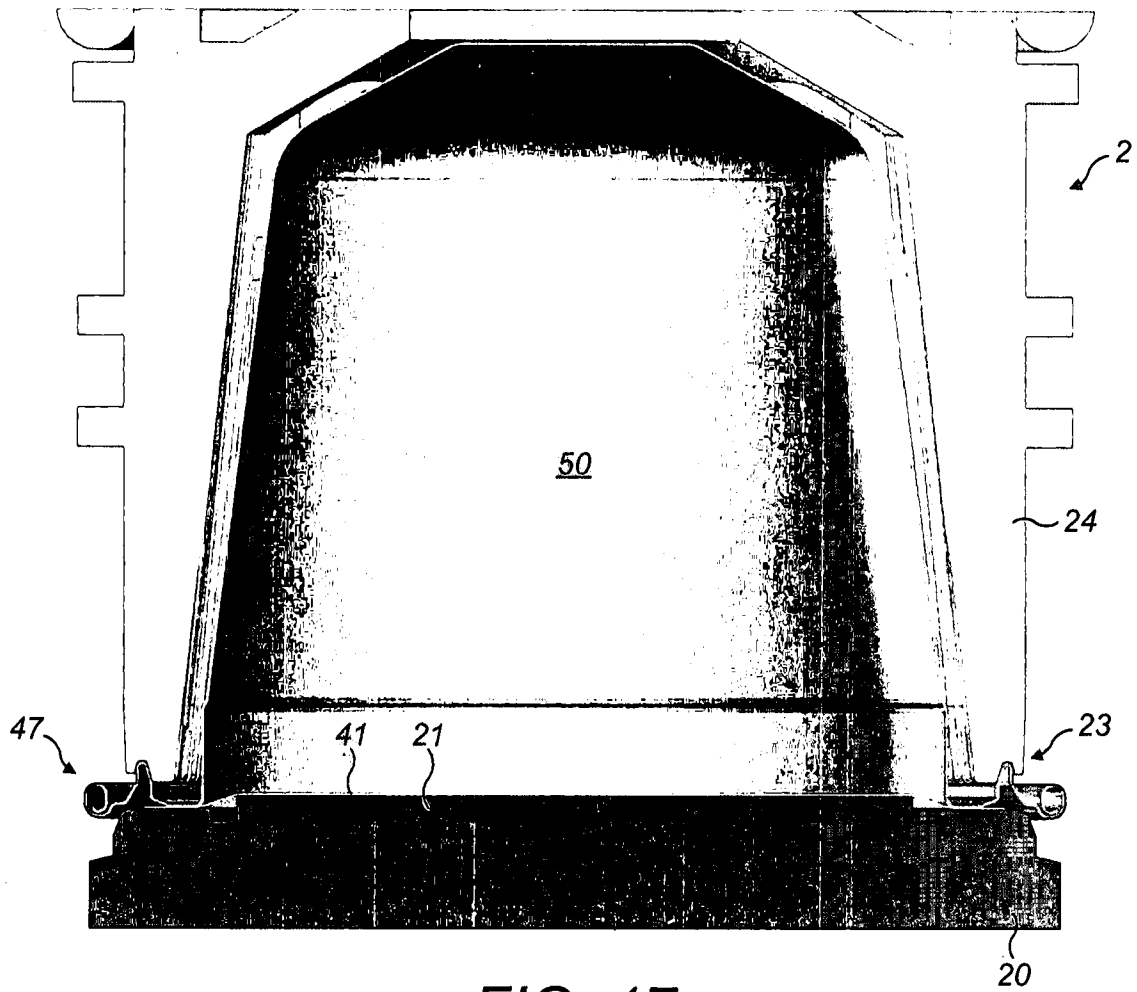

FIG. 17

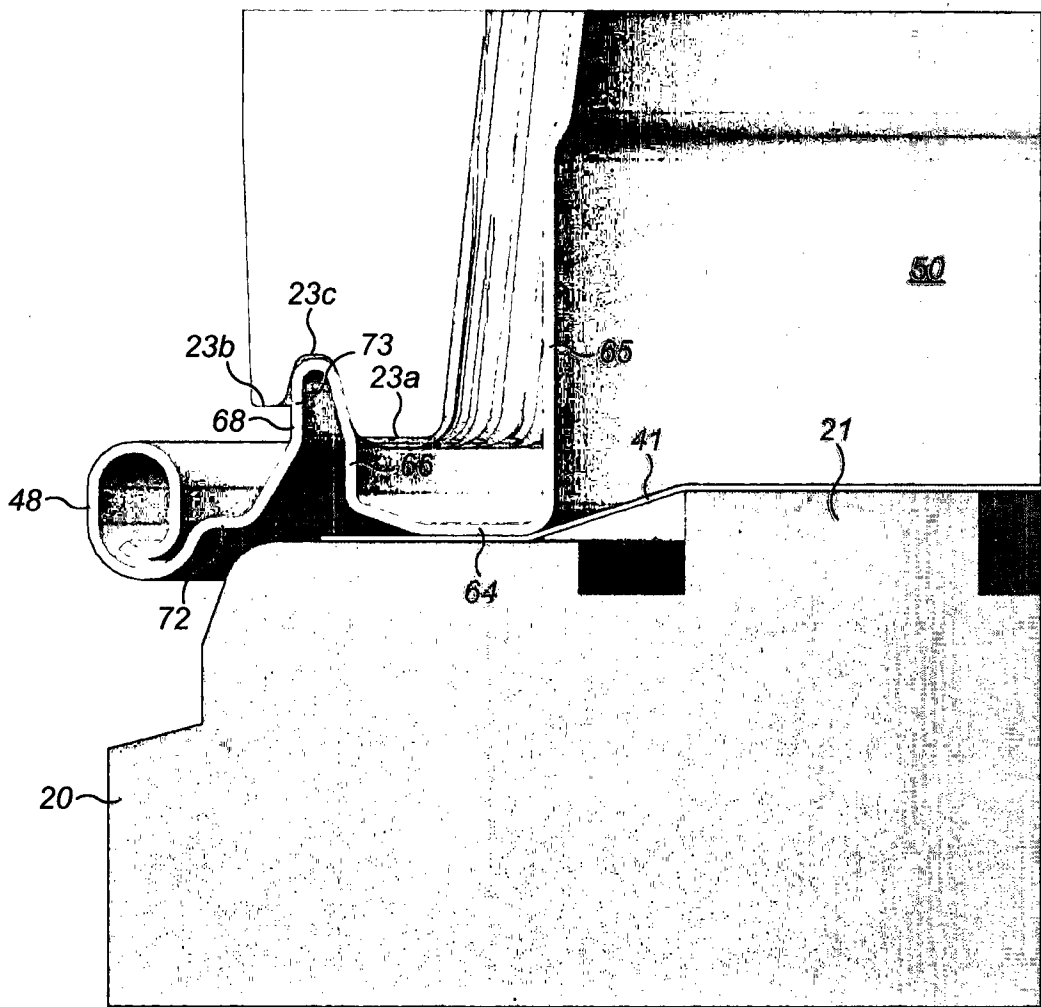

FIG. 18