

E. J. CUBLEY.

EMBROIDERY ATTACHMENT FOR SEWING MACHINES.

No. 103,578.

Patented May 31, 1870.

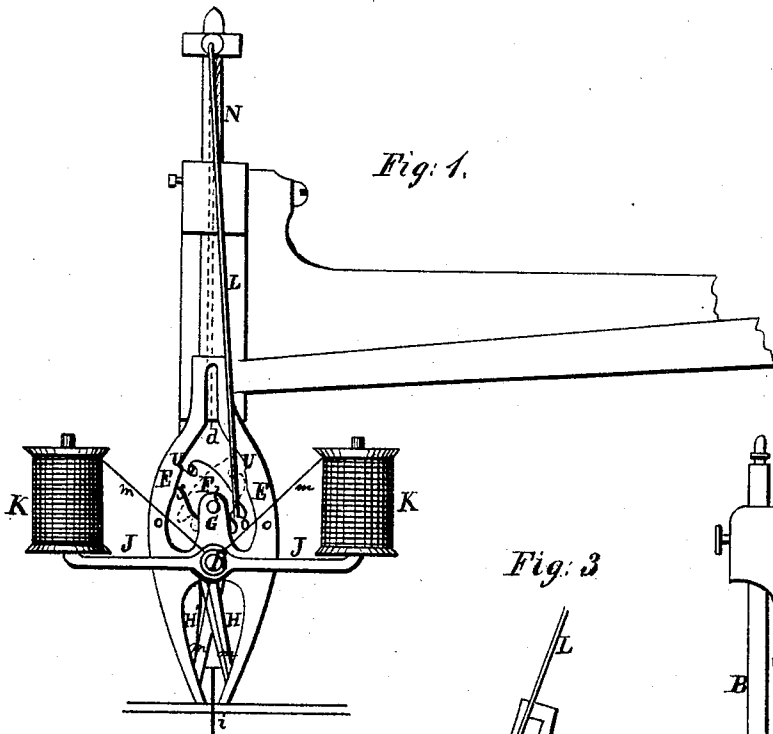

Fig. 1.

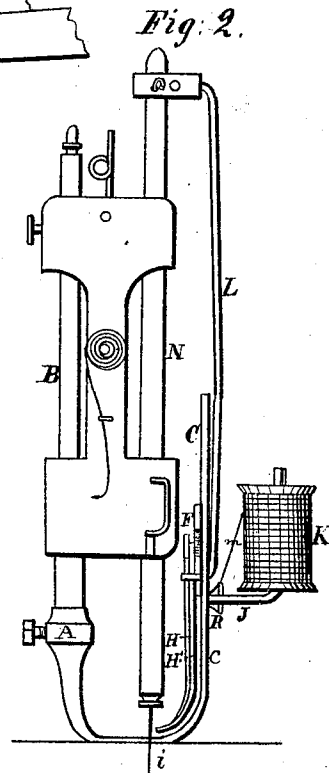

Fig. 2.

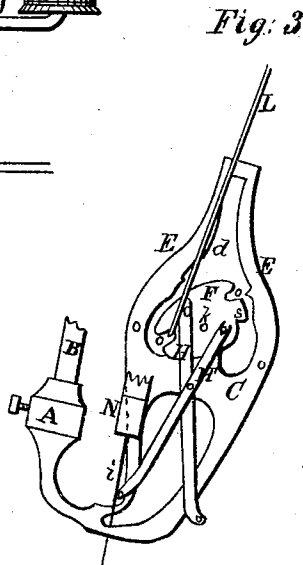

Fig. 3.

Witnesses:  
*G. N. Frost*  
*C. J. Powers*

Inventor:  
*Edwin J. Cubley*  
*By Farwell, Allworth & Co*  
attorneys.

# United States Patent Office.

EDWIN J. CUBLEY, OF CHICAGO, ILLINOIS.

Letters Patent No. 103,578, dated May 31, 1870.

## IMPROVEMENT IN EMBROIDERY-ATTACHMENT FOR SEWING-MACHINES.

The Schedule referred to in these Letters Patent and making part of the same

To all whom it may concern:

Be it known that I, EDWIN J. CUBLEY, of Chicago, in the county of Cook and State of Illinois, have invented a new and useful Embroidering Attachment for Sewing-Machines; and I do hereby declare the following to be a full, clear, and exact description thereof, which will enable others skilled in the art to which my invention appertains, to make and use the same, reference being had to the accompanying drawings forming part of this specification.

Figure 1 is a front elevation of my improved embroidery-attachment applied to a sewing-machine;

Figure 2 is a side elevation in position for use; and

Figure 3 is a perspective view of the same detached from the machine.

Similar letters of reference indicate corresponding parts in the several figures of the drawing.

My invention has for its object to provide an embroidery-attachment for that class of sewing-machines known as "shuttle-machines," but equally applicable to those in which a single thread is employed. To this end,

It consists in the combination of parts, as will be hereinafter more fully described.

In the accompanying drawings—

A is the presser-foot of the machine, attached to the bar B by means of a set-screw, in the usual manner. It is provided with an upright projection in the form of a plate, C, extending upward outside of the needle-bar, and parallel with the same.

The upper portion of the plate is cut out and slotted, as shown at *d*, to form the two guide-arms E E.

F is the oscillating plate, pivoted centrally to the inner surface of the projection G between the guide-arms, as shown at *k*.

H H' are the thread-carrying arms, hung one over the other to a common pivot, *h*, upon the inner surface of the projection G. Their lower ends are bent toward the needle *i* of the machine, and work immediately in front of the same, as will be hereinafter described.

The upper end of the arm H is pivoted to the oscillating plate F above the central pivot *k*, and the arm H' below said pivot in the same line.

The upper ends of both arms are slotted or notched to permit their motion when the plate F is oscillated.

The spools of thread K, to be used for embroidering, are mounted upon arms J, projecting from each side of the plate C, as shown in fig. 1.

The operation is as follows:

The embroidering thread *m* is first passed from the spools K through the holes or loops formed in the lower ends of the arms H H', and the machine set in motion.

L is an arm, attached to the needle-bar N, and bent

at right angles at its lower end, to enter the slot *d* in the plate C.

As the needle-bar descends, the bent end of the arm L comes in contact with the top or upper edge of the oscillating plate F, along which it rides, to throw the latter into an inclined position, as shown in fig. 1.

The arm continues to move down until it slips off the plate, and catches into one of the notches *o*, formed in opposite edges of said plate.

When the needle-bar rises, the arm L lifts the plate until the notch *o* is opposite one of the shoulders U, formed in the arms E, as shown, when the arm L releases the plate F, and leaves it inclined in a direction opposite to its first position.

By this arrangement, the plate F is inclined alternately in opposite directions, and as the arms H and H' are pivoted thereto, one above the other, they are caused to vibrate rapidly across each other, crossing the embroidering threads in front of the needle at each vibration.

The plate F is cut away upon its lower edge to form shoulders *s*, which, as the plate oscillates, strike the pivot, and prevent said plate from being thrown too far to one side.

The needle of the machine makes a stitch to secure the embroidering threads to the goods, at the points of intersection of the latter threads.

The arm L is made elastic, and, when not in operation, occupies a central position within the slot *d* of the plate C.

When, however, it is carried down by the needle-bar, it is forced to the side by the inclination of the plate F, and its elasticity throws it within the notches *o*, when it has cleared the upper surface of said plate.

By this construction, the tendency of the arm is always toward the center of the slot *d*, and, therefore, there is no possibility of its failing to enter the notches of the oscillating plate.

A tension-device, R, of suitable construction, is attached to the plate C between the spool-arms, for regulating the tension of the embroidering-threads.

Having thus described my invention,

What I claim as new, and desire to secure by Letters Patent, is—

The combination with the presser-foot and its upwardly-projecting plate C, of the oscillating plate F, having the notches and pins, and the pivoted slotted arms, all constructed as described, and operated from the needle-bar through the bar L, substantially as herein set forth for the purpose specified.

EDWIN J. CUBLEY.

Witnesses:

G. H. FROST,

E. A. ELLSWORTH