

J. A. RABBITT.
 MOTOR FOR TALKING MACHINES.
 APPLICATION FILED FEB. 28, 1910.

996,522.

Patented June 27, 1911.

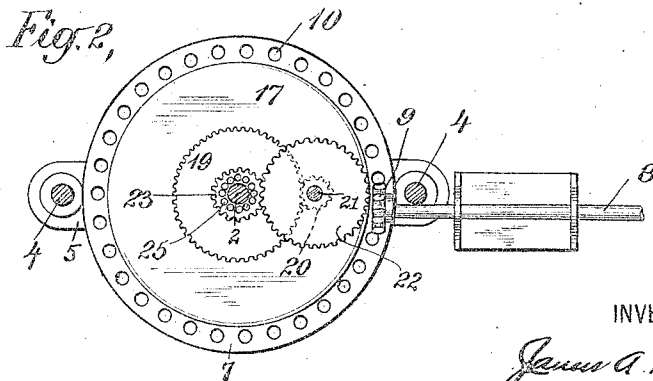
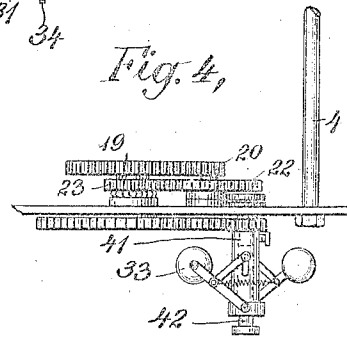
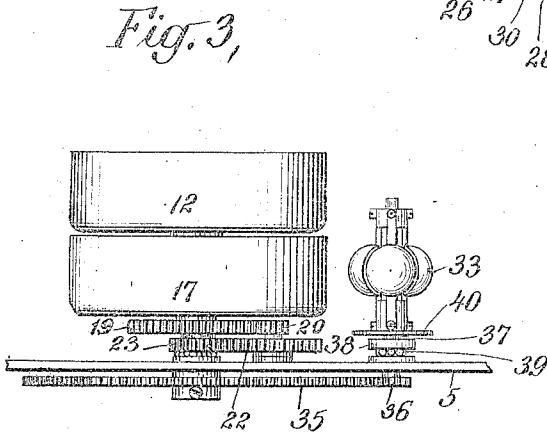
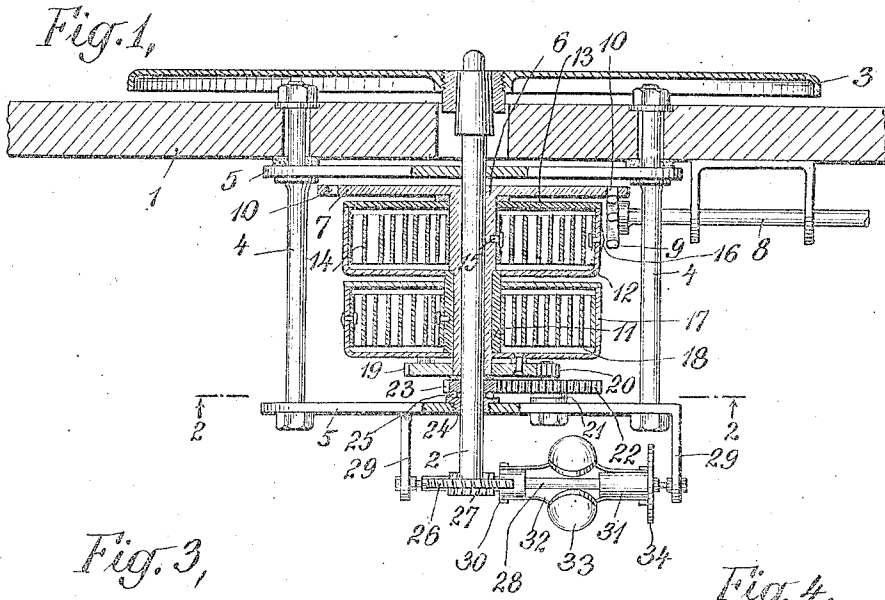

WITNESSES:
Edmund
Henry Meyer

INVENTOR
James A. Rabbitt
 BY *Edmund*
 ATTORNEY

UNITED STATES PATENT OFFICE.

JAMES A. RABBITT, OF YOKOHAMA, JAPAN.

MOTOR FOR TALKING-MACHINES.

996,522.

Specification of Letters Patent. Patented June 27, 1911.

Application filed February 28, 1910. Serial No. 546,271.

To all whom it may concern:

Be it known that I, JAMES A. RABBITT, a citizen of the United States, residing at Yokohama, in the Empire of Japan, have invented certain new and useful Improvements in Motors for Talking-Machines, of which the following is a description.

This invention relates to motors adapted for use in driving the record-holder of a talking-machine, and its object is to provide an improved form of spring-motor for this use which has ample power, which occupies small space and is of such simple construction that it may be manufactured at small cost.

My invention contemplates the provision of a spring-motor having a plurality of springs to furnish the motive power, these being compactly arranged and so connected that the power of one is added to that of another. The improved construction is such that a convenient and inexpensive form of winding device is employed not requiring a train of gears, the use of heavy castings is avoided, bevel-gears connecting the motor to the record-holder are eliminated, and an adjustable ball-bearing is provided for the main shaft to insure easy running.

The preferred embodiment of the invention is illustrated in the accompanying drawing, in which—

Figure 1 is a central sectional view of the motor, Fig. 2 is a view in section on line 2—2 of Fig. 1 showing the winding mechanism, and Figs. 3 and 4 are detail views showing modified forms of governors.

Referring to these drawings, 1 indicates the support for the motor, as the top of the motor-box of a talking machine having an opening therein through which extends a shaft 2 carrying the turntable 3. Secured to the support 1 are two bolts 4, which depend from the support 1 and have two plates 5 secured thereto. On the central shaft 2 is a sleeve 6 having a plate 7 secured to or formed integral with the same at the top thereof. This plate has a plurality of holes 10 punched therein and disposed in a circle, as indicated in Fig. 2. A winding-shaft 8, adapted to be actuated by a suitable handle, has a gear-wheel 9 secured thereto with its teeth adapted to enter the holes 10 in the disk 7 and rotate the latter when the winding-handle is actuated.

Loosely mounted on the sleeve 6 is a sec-

ond sleeve 11, to which is secured one portion of a spring-box 12, the cover 13 of which is adapted to turn loosely upon the sleeve 6. A tempered steel spiral spring 14 has one end secured to the sleeve 6 by a pin 15, and the other end secured to the box 12 by a pin 16. On the sleeve 11 is a spring-box 17 adapted to turn freely relatively to the sleeve 11, and within this box is a similar spring 18 having one end secured to the box and the other end secured to the sleeve 11.

To the bottom of the spring-box 17 is secured a gear 19 adapted to turn loosely upon the sleeve 6 on which it is mounted. This gear 19 meshes with a pinion 20 which is loosely mounted upon a shaft 21 secured to the bottom-plate 5. Secured to or formed integral with the pinion 20 is a gear 22, which meshes with a pinion 23 secured to the central shaft 2.

In the bottom-plate 5 is a threaded opening having an adjustable threaded bushing 24 therein, and the adjacent faces of this bushing 24 and the pinion 23 are formed to provide a ball-race adapted to receive a plurality of balls 25 forming a ball-bearing for the shaft 2.

It will be seen that when the turntable is released, the spring 14 will act to turn the spring-box 12 and the sleeve 11 upon the sleeve 6, and that the spring 18 will similarly act to turn the spring-box 17 and the gear 19 secured thereto, so that the power applied to the gear 19 is the combined power of the two springs 14 and 18 acting in series. The rotation of gear 19 is transmitted to the central shaft 2 through the gears 20, 22 and 23. When the springs have become partially unwound, they may be again wound up by operating the shaft 8 by means of its handle. Turning shaft 8 thus operates to turn the disk 7, and with it the sleeve 6, thus winding the spring 14 and causing the spring-box 12 and sleeve 11 to rotate sufficient to wind the spring 18.

In order to properly regulate the speed at which the turntable will be rotated, a centrifugal governor is provided. As shown in Fig. 1, the central shaft 2 is extended below the bottom-plate 5 and carries a spiral gear 26 meshing with a spiral pinion 27 on a horizontal shaft 28. This shaft is supported in bearings formed in arms 29 depending from the bottom-plate 5. Secured to shaft

28 is a collar 30, and a collar 31 is loose on the shaft. These two collars are connected by leaf-springs 32, each carrying a weight 33. As the shaft 2 is rotated by the motor, 5 the shaft 28 will be correspondingly rotated and the weights 23 will move outwardly in accordance with the speed of rotation. This causes the collar 31 to be moved axially on shaft 28, and a disk 34 secured to the collar 10 31 will coact with the brake-lever in a manner common in the art.

Referring to Fig. 3, a modification of the arrangement of the governor is shown. In this figure, the central shaft 2 carries a large 15 gear 35, which meshes with a pinion 36 on a vertical shaft 37 mounted in a bearing in the bottom-plate 5. This shaft has a collar 38 secured thereto and resting on balls 39 retained in a suitable ball-race. The governor 20 itself is like that described above in connection with Fig. 1, the movement of the weights 33 causing the disk 40 to move axially of shaft 37.

A further modification in the form of governor is shown in Fig. 4, wherein the shaft 25 37 is in the form of a sleeve 41 adapted to receive a pin 42. This pin 42 is caused to

move axially within the sleeve 41 by the movement of the weights 33.

Having now described my invention, what 30 I claim as new therein and desire to secure by Letters Patent is as follows:—

A spring-motor comprising the combination of a power-shaft, a sleeve loose thereon, a toothed winding-gear on said sleeve, a 35 winding pinion engaging said gear, a second sleeve loosely mounted upon said sleeve, a spring having its inner end connected to said first-named sleeve, a member connecting the outer end of the spring to said second 40 sleeve, a second spring connected at one end to said second sleeve, a gear concentric with said sleeve, means for connecting the other end of said second spring to said gear, an 45 auxiliary shaft driven by said last-mentioned gear, and intermeshing gears on the power-shaft and said auxiliary shaft, substantially as set forth.

This specification signed and witnessed this 5th day of February, 1910.

JAMES A. RABBITT.

Witnesses:

GENJI KURIBARA,
MASATARO OKASAVA.