

R. C. FRAMPTON.
 INSTANTANEOUS WATER HEATER.
 APPLICATION FILED FEB. 4, 1910.

998,083.

Patented July 18, 1911.

2 SHEETS—SHEET 1.

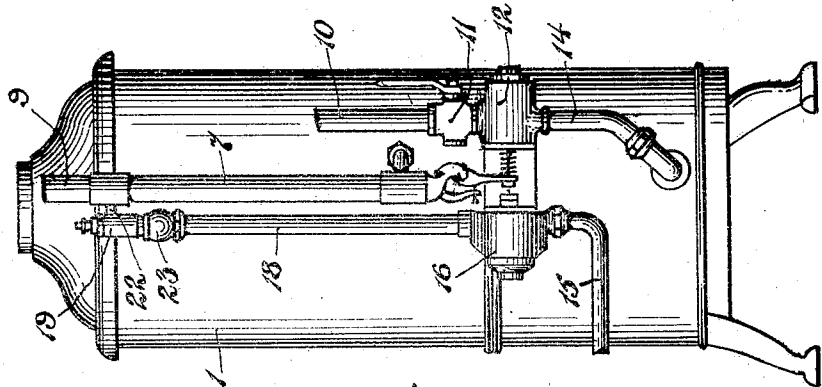

Fig. 2.

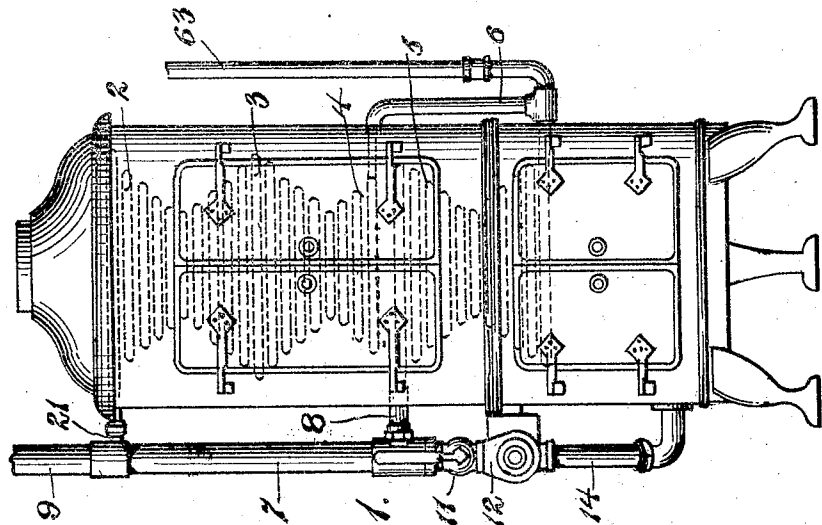

Fig. 1.

WITNESSES

Harvey L. Lechner
Dorothy Bellinger.

INVENTOR

Reynolds C. Frampton
 by *Paul Chaperonnet*

UNITED STATES PATENT OFFICE.

REYNOLDS C. FRAMPTON, OF SWISSVALE, PENNSYLVANIA.

INSTANTANEOUS WATER-HEATER.

998,083.

Specification of Letters Patent. Patented July 18, 1911

Application filed February 4, 1910. Serial No. 542,611.

To all whom it may concern:

Be it known that I, REYNOLDS C. FRAMPTON, a citizen of the United States, residing at Swissvale, in the county of Allegheny and State of Pennsylvania, have invented certain new and useful Improvements in Instantaneous Water-Heaters, of which the following is a specification.

The invention relates to mechanism for controlling the gas supply to the burners of instantaneous water heaters, and particularly to the structure of the controlling water valve where such valve is employed in conjunction with a thermostat for securing a double regulation of a single gas valve. The invention has for its objects the provision of an improved water valve construction wherein the stem of the valve may be retracted by the thermostat independently of the water valve piston; and the provision of a water valve of the character specified which is self-contained, and in which all danger of the sticking of the operating stem is eliminated. One embodiment of the invention is illustrated in the accompanying drawings, wherein:—

Figure 1 is a front view of the heater,

Figure 2 is a side elevation thereof,

Figure 3 is an enlarged detail partly in section, of the controlling mechanism, and

Figure 4 is an enlarged detail of the valve shown in the upper portion of Figure 3 with its piston in the position occupied when the outlet from the heater is open, the section being taken at right angles to that of Figure 3.

Heretofore it has been customary in instantaneous water heaters to provide two independent gas valves, one of which is controlled from the motor valve, or water valve as it is more commonly termed, and the other valve is controlled by the thermostat, such general construction being illustrated in my copending application Serial, No. 457,383. I have found that one of these gas valves may be dispensed with, and that the controlling means therefor may be so arranged that all the advantages incident to the two valve construction are retained, and other advantages not present in the two-valve construction secured, in addition to the general simplification and cheapening of the apparatus due to the use of one valve instead of two.

That portion of the apparatus in which the departure of this application particu-

larly resides is illustrated in the lower portion of Figure 3, but in order that the relation of this structure to the general heater construction may be clear; the entire heater is illustrated and will be described, reference being had to my co-pending application 457,383 heretofore referred to, for a detail description of that portion of the apparatus shown and described but not claimed.

Referring first to the general arrangement of parts as shown in Figures 1, 2 and 3; 1 is the casing of the heater; 2, 3 and 4 are the upper sets of coils of the boiler; 5 is the lower inverted set of coils, the lower coil of which set is connected to the lower coil of the set 3 by means of the pipe 6; 7 is the thermostat casing, which casing communicates with the upper coil of the set 5 by means of the pipe 8, and is provided with an outlet 9 for the hot water which is to be distributed; 10 is the gas inlet pipe provided with the usually manually operated valve 11; 12 is the gas valve casing, the valve 13 of which is automatically controlled from the thermostat and water valve in a manner to be hereinafter described; 14 is the gas pipe leading from the valve casing to the burners; 15 is the water supply pipe leading to the automatic water valve casing 16; 17 is the piston valve in the casing; 18 is a water pipe leading from the valve casing 16 to the casing 19 of the controlling check valve 20; 21 is a pipe leading from the casing 19 to the upper coil of the set 2; 22 is a tube leading from the upper portion of the casing 19 to the upper portion of the thermostat casing 7; and 23 is a pressure regulating valve whose construction may be of any approved type and is immaterial insofar as the invention of this application is concerned. From the foregoing the general operation of the heater will be apparent and may be briefly stated as follows. A faucet in the outlet 9 being opened, a flow of water occurs through the inlet 15 causing the piston valve 17 to move to the right (Fig. 3) and thence up through the pipe 18 to the check valve 20, moving such valve to the position of Figure 4, so that the water passes through the pipe 21 into the heater. The water then circulates down through the coils 2, 3 and 4, the connection 6, up through the coil 5; the connection 8, the thermostat casing 7, and to the outlet 9. When the faucet in the outlet 9 is closed,

the valve 17 moves back to the position indicated in Figure 3, and the check valve 20 moves down and seats itself as indicated in this figure. When the valve 20 is in this lower position, a circulation occurs from the lower coil 5 to the casing 7 and thence through the connection 22, valve casing 19, and connection 21 to the top coil of the boiler.

The construction wherein the invention of this present application particularly resides will now be described in detail, reference being had to Figure 3 of the drawings.

The thermostat here shown is of the ordinary type, and comprises the copper or brass tube 24 closed at its upper end, and the porcelain rod 25 fitting the tube and provided at its lower end with the usual metal cap 26 from which the levers 27 and 28 are operated. The lower end of the lever 28 is provided with a hole for the passage of the stem 29 of the gas valve 13, which stem 29 is longitudinally adjustable with respect to the valve 13 by means of the set screw 30. The collar 31 is also secured slidably upon the stem 29, and carries thereon an adjustable collar 32 against which a spring 33 bears. The end of the stem 29 is provided with a cap 34, and the thermostat and its levers are so adjusted that when the temperature of the water in the thermostat casing 7 is below the maximum for which the device is set, say below 150 degrees, the lower end of the lever 28 occupies about the position indicated in Figure 3 with a space between the cap 34 and the end of the lever, so that the stem 29 and the gas valve 13 carried thereby may be normally operated from the water valve without interference with the thermostatic controlling means. When the outlet 9 is closed the piston 17 of the water valve is held in the position indicated in Figure 3 by means of the spring 35 which spring bears at its rear end against the screw cap 36 of the casing 37. The spring 35 thus serves the double function of holding the casing 37 in position and maintaining the piston 17 in its rearmost position. The casing 37 is provided at its front end with the tube 38 which passes through the stuffing box of the valve casing. Mounted in the tube 38 is the rod 39 carrying at its rear end the cap 40 which is held in its forward position in the casing by means of the spring 41. The gas valve 13 is held normally in closed position by means of the spring 42, and the combined strength of this spring and the spring 33 is somewhat greater than that of the spring 41. The strength of the spring 42 alone is less than that of either the springs 41 or 35.

The combined action of the water valve and thermostatic controlling means in connection with the gas valve is as follows. If the outlet from the heater is opened, the pressure upon the left hand end of the pis-

ton 17 overbalances the pressure on the other side because of the reduction of pressure in the tube 18 and the piston is forced to the right compressing the spring 35 and moving the rod 39 so that its front end engages the cap 34, thus opening the gas valve 13 and permitting a flow of gas to the burners. If now the outlet from the heater is closed and the piston 17 accidentally sticks in its right hand position, the temperature of the water in the boiler and in the thermostatic casing 7 rises to a point above that for which the device is set, and the lever 28 under the influence of the spring 33 moves to the left carrying with it the cap 34, which in turn forces the rod 39 to the left compressing the spring 41 at the other end of such rod. This compression of the spring 41 is assured by reason of the fact that the combined strength of the spring 42 and spring 33 is greater than that of the spring 41 as heretofore pointed out. In this manner the closure of the gas valve is provided for regardless of the closure of the piston valve 17.

It will be seen that the actuation of the gas valve by the water valve is not in anywise interfered with by the thermostatic controlling means during the normal operation of the apparatus. In addition to acting as a safety device under the condition above set forth when the water valve sticks open, the thermostatic means also acts as a controlling device when the water valve is acting normally without sticking, and in case the water rises above a predetermined temperature the flow of gas is throttled or entirely cut off without altering the position of the water valve. The use of the tube 38 obviates any danger of sticking which might possibly otherwise occur if no tube were used, and the rod 39 had to be packed in order to prevent leakage. The casing 37 is made water tight so that the rod 39 may fit as loosely as is desired in the tube 38. It will also be seen that under the condition of non-closure of the water valve as above described, a very positive and secure closing of the gas valve is secured by reason of the fact that the pressure of the powerful spring 33 augments that of the weaker spring 42 inclosing the gas valve. This very much reduces the danger of imperfect closure of the gas valve due to foreign matter upon the seat, as the two springs are sufficient to cause a closure in cases where the spring 42 alone would close the valve so imperfectly as to permit the passage of a large amount of gas. It will also be seen by comparison of this apparatus with the two valve constructions as heretofore used, that the structure is very much cheapened and simplified, and this without any loss of effectiveness of operation.

The construction of the controlling check valve is illustrated most clearly in Figures

3 and 4, and although this structure forms a portion of the subject-matter claimed in the co-pending application heretofore referred to, I will briefly describe the device in order that the description of the apparatus shown may be complete. By reference to the figures referred to, it will be seen that the casing 19 is provided with an inlet passage 54 and a pair of circulation passages 55 and 56, leading respectively to the connection 21 to the upper coil of the boiler, and to the connection 22 leading to the thermostat casing 7.

Screw threaded into the end of the casing 19, is a bushing 57, and slidable in this bushing is the piston valve 20 having the two heads 58 and 59. The bushing is also provided with two sets of ports 60 and 61 leading respectively to the passages 55 and 56. The piston valve is held normally in the position shown in Figure 3 with its head covering the feed port 54 by means of the spring 62. The valve parts occupy the position shown in Figure 3, when no water is being drawn through the outlet 9. With the parts in this position water from the inverted or reverse coil 5 may circulate freely to the upper coil 2 through the connection 8, the casing 7, the connection 22, the ports and passages of the valve casing 19 and the connection 21. A return circulation to the boiler is also provided for by means of the pipe 63, and a continuous double circulation may be maintained, a part of the water from the thermostat casing passing up through the outlet 9 and around through the system and back to the return pipe 63, while another portion passes through the connection 22 to the casing 19, and thence back to the upper coil of the boiler. If the outlet through the pipe 9 is opened, the piston valve will assume the position shown in Figure 4 by reason of the unbalanced pressure on the opposite sides of such valve, and the upflow through the inlet pipe 18. When the parts are in this position the water from the pipe 18 will pass through the valve casing 19 and out through the passage 55 and connection 21 to the upper coil of the boiler, and thence through the coils of the boiler, the thermostat casing 7, and the outlet pipe 9.

Having thus described my invention and illustrated its use, what I claim as new and

desire to secure by Letters Patent is the following:

1. In an instantaneous water heater, a burner, a normally closed fuel valve, thermostatic controlling means for closing the valve when the temperature of the water rises above a predetermined point, and a water actuated valve for opening the fuel valve and comprising a valve casing having inlet and outlet ports, a piston for controlling the ports, a stuffing box, a spring for holding the piston in position to close one of the ports; a closed casing carried by the piston and provided with a tube extending through the stuffing box, an auxiliary spring in the casing, and a rod held in forward position by the auxiliary spring extending through the tube and adapted to operate the fuel valve.

2. In an instantaneous water heater, a burner, a normally closed fuel valve, thermostatic controlling means for closing the valve when the temperature of the water rises above a predetermined point, and a water actuated valve for opening the fuel valve and comprising a valve casing having inlet and outlet ports, a piston for controlling the ports, a stuffing box, a spring for holding the piston in position to close one of the ports; a rod extending through the stuffing box and adapted to operate the fuel valve and an auxiliary spring in the valve casing interposed between the rod and piston.

3. In combination in a water valve for an instantaneous heater, a valve casing provided with ports and a stuffing box, a piston for controlling the flow between the ports, a spring for holding the piston in position to cut off communication between the ports, a closed casing carried by the piston and provided with a tube extending through the stuffing box, an auxiliary spring in the casing, and a rod extending through the tube and held yieldingly in forward position by the auxiliary spring.

In testimony whereof I have hereunto signed my name in the presence of the two subscribed witnesses.

REYNOLDS C. FRAMPTON.

Witnesses:

JAMES C. BRADLEY,
JOHN V. WHITE.