



AU9223402

(12) PATENT ABRIDGMENT (11) Document No. AU-B-23402/92
(19) AUSTRALIAN PATENT OFFICE (10) Acceptance No. 659862

- (54) Title
A PRESSURE BALANCED TORSION SYSTEM FOR A BACKREST AND THE LIKE
- International Patent Classification(s)
(51)^s **A47C 007/28 A47C 007/40 A47C 023/00**
- (21) Application No. : **23402/92** (22) Application Date : **23.07.92**
- (87) PCT Publication Number : **WO93/03652**
- (30) Priority Data
- | | | |
|----------------|-----------------|------------------|
| (31) Number | (32) Date | (33) Country |
| 2049580 | 20.08.91 | CA CANADA |
- (43) Publication Date : **16.03.93**
- (44) Publication Date of Accepted Application : **01.06.95**
- (71) Applicant(s)
YUN HUI ZHANG
- (72) Inventor(s)
YUN HUI ZHANG
- (74) Attorney or Agent
PATENT ATTORNEY SERVICES , 26 Ellingworth Parade, BOX HILL VIC 3128
- (56) Prior Art Documents
US 4326311
US 2293323
DE 672258
- (57) Claim

1. A pressure balanced torsion system for use in a backrest and the like, comprising

a first pressure bearing plate means and a second pressure bearing plate means, each of said first pressure bearing plate means and second pressure bearing plate means having a front surface and a rear surface opposite to said front surface,

an elongated torsion spring means including a first arm portion having a free end mounted to said rear surface of said first pressure bearing plate means, and a second end mounted to one side of a rocker member, said torsion spring means including a second arm portion having a free end mounted to said rear surface of said second pressure bearing plate means, and a second end mounted to a second side of said rocker member, said second side of said rocker member being directly located opposite to said one side,

said rocker member being pivotally mounted on a support plate.



INTERNATIONAL APPLICATION PUBLISHED UNDER THE PATENT COOPERATION TREATY (PCT)

(51) International Patent Classification ⁵ : A47C 7/24, 23/00	A1	(11) International Publication Number: WO 93/03652
		(43) International Publication Date: 4 March 1993 (04.03.93)

(21) International Application Number: PCT/CA92/00312	Published With international search report. 659862
(22) International Filing Date: 23 July 1992 (23.07.92)	
(30) Priority data: 2,049,580 20 August 1991 (20.08.91) CA	
(71)(72) Applicant and Inventor: ZHANG, Yun, Hui [CN/CA]; 52 Oak Avenue, Richmond Hill, Ontario L4C 6R7 (CA).	
(74) Agent: WONG, David, W.; 46 Willowbrook Road, Thornhill, Ontario L3T 4W9 (CA).	
(81) Designated States: AU, JP, KR, RU, European patent (AT, BE, CH, DE, DK, ES, FR, GB, GR, IT, LU, MC, NL, SE).	

(54) Title: A PRESSURE BALANCED TORSION SYSTEM FOR A BACKREST AND THE LIKE

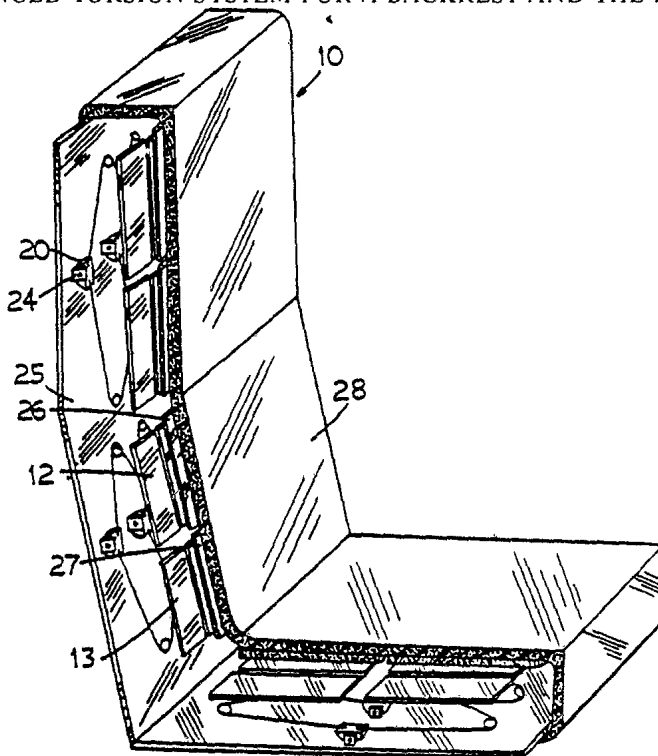

(57) Abstract

A pressure balanced torsion system for use in a backrest and the like comprises a plurality of pairs of pressure bearing plates (12, 13) coupled to a torsion spring means. The torsion spring means (14, 15) is pivotally mounted to a support back plate (25). When an external pressure is exerted onto the pressure bearing plates (12, 13) by a human body resting against them, the counter reactive force generated by the torsion spring (14, 15) in the system will cause both pressure bearing plates (12, 13) to push against the human body until the counter reactive force is balanced in both pressure bearing plates; thus providing a balanced counter pressure against the human body to provide a uniform support therefor.

A PRESSURE BALANCED TORSION SYSTEM FOR A BACKREST AND THE LIKE
BACKGROUND OF THE INVENTION

This invention relates to a body support system and more particularly relates to a torsion system suitable for use in a backrest and the like, which is self-adjusting to a pressure balanced state to conform to the human body contour so as to provide a complete support therefor even as the body moves relative to the support.

Commonly, backrests do not provide a full support to the human body resting against it, mainly because of the irregular curvature of the back in the human body. Some back rests attempt to provide a better support to the human body by providing various protrusions at predetermined fixed locations therein so that all areas of the back of the human body are in contact with a fixed support when resting against the same. Such fixed backrests do not provide any reactive pressure to support the human body.

Another common support uses a plurality of compression and/or tension springs. In such system, a plurality of such compression springs, such as coil springs, are mounted within a collapsible frame bounded with an outer covering material. When a person rests against such system, the coil springs at the various areas are being compressed by the human body so that the system in the backrest or mattress would conform with the contour of the human body to provide a support therefor. However, the main drawback of such system is that only the springs being compressed would exert a counter reactive force against the corresponding areas of the human body exerting the compression force thereto. The curved-in or depression areas of the human body which are not in contact with the back rest would not receive any reactive force from the backrest. Therefore, such system do not provide a uniform pressure

balanced support to the human body resting against it, resulting in the muscle in the unsupported areas to tense up. The long term effect in using such backrest and mattress would result in body fatigue and the development of muscle pain.

SUMMARY OF THE INVENTION

5 It is a principal object of the present invention to provide a body support system which exerts a balanced counter force against the body support system which exerts a balanced counter force against the body resting against it for providing a uniform support therefor.

It is another object of the present invention to provide a body support system which reacts to the body movement to provide a constant uniform balanced support to the body.

10 It is another object of the present invention to provide a pressure balanced torsion system which is relatively simple in construction.

The system according to the present invention comprises a pressure balanced torsion system for use in a backrest and the like, comprising a first pressure bearing plate means and a second pressure bearing plate means, each of said first pressure bearing plates means and
 15 second pressure bearing plate means having a front surface and a rear surface opposite to said front surface, an elongated torsion spring means including a first arm portion having a free end mounted to said rear surface of said first pressure bearing plate means, and a second end mounted to one side of a rocker member, said torsion spring means including a second arm portion having a free end mounted to said rear surface of said second pressure bearing plate
 20 means, and a second end mounted to a second side of said rocker member, said second side of said rocker member being directly located opposite to said one side, said rocker member being pivotally mounted on a support plate.



According to another aspect of the invention there is provided in a human body support device having a plurality of pressure balanced torsion means mounted on a substantially rigid support means, said torsion means comprising, a U-shaped bracket member mounted on said support means, a rocker member pivotally mounted on side U-shaped bracket member, said rocker member having one side and a second side, and said rocker member being pivotal from said one side to said second side relative to said bracket member, a first pressure bearing plate means having a front surface and a rear surface located opposite to said front surface, a second pressure bearing plate means having a front surface and a rear surface located opposite to said front surface, an elongated torsion spring means having a first arm portion with a free end therein pivotally mounted to said rear surface of said first pressure bearing plate means, and a second end therein mounted to said one side of said rocker member, said torsion spring means having a second arm portion with a free end therein pivotally mounted to said rear surface of said second pressure bearing plate means, and a second end therein mounted to said second side of said rocker member.

15 According to a still further aspect of the invention there is provided a pressure balanced torsion system for use in a backrest and the like, comprising a plurality of torsion balanced means located between a flexible retaining sheet means and a fixed support plate, each of said torsion balanced means including a first pressure bearing plate means and a second pressure bearing plate means, each of said first pressure bearing plate means and second pressure bearing plate means having a front surface and a rear surface located opposite to said front surface, and elongated torsion spring means including a first arm portion having a free end therein pivotally mounted to said rear surface of said first pressure bearing plate means, and second end therein mounted to one side of a rocker member, said torsion spring

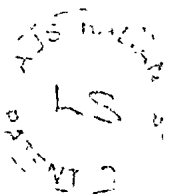

2b

means including a second arm portion having a free end therein pivotally mounted to said rear surface of said second pressure bearing plate means, a second end therein mounted to a second side of said rocker member, said second side of said rocker member being directly located opposite to said one side, and said rocker member being pivotally mounted on said

5 fixed support plate.

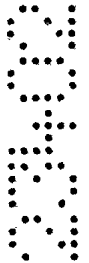

30

balanced support to a human body resting against them.

Other objects of this invention will appear in the following description and appended claims, reference being made to the accompanying drawings.

5 BRIEF DESCRIPTION OF THE DRAWINGS

Figure 1 is a partial cut-away perspective elevation view of a seat having a pressure balanced torsion system in its backrest and seat areas therein according to the present invention.

10 Figure 2 is a perspective elevation view of the pressure balanced torsion system according to the present invention.

Figure 3 is a perspective elevation view of the torsion spring means used in the torsion system according to the present invention.

15 Figure 4 is a partial cut-away perspective view of the rocker member in the torsion system according to the present invention.

Figure 5 is a top elevation view of the rocker member thereof.

20 Figure 6 is a side elevation view of the rocker member thereof.

Figure 7 is a perspective elevation view of the mounting bracket for the rocker means thereof.

25 Figure 8 is a schematic diagram showing the operation of the pressure balance torsion system according to the present invention.

30 Figure 9 is a schematic diagram showing the operation of two torsion systems in a backrest with the pressure bearing plates abutting intimately with the covering to conform with a human body contour according to the present invention.

Figure 10 shows a two-level construction of the torsion system according to the present invention.

Figure 11 is a perspective elevation view of the torsion

system using a torsion spring having a second embodiment.

Figure 12 is a perspective elevation view of a third embodiment having a torsion spring with a flat body.

Figure 13 is a perspective elevation view of a fourth
5 embodiment of the torsion system having a single torsion spring according to the present invention.

Figure 14 is a perspective elevation view of a fifth embodiment of the torsion system having a single plate type torsion spring.

10 DETAILED DESCRIPTION OF THE PREFERRED EMBODIMENTS

With reference to the drawings wherein like reference numerals designate corresponding parts in the several views, a seat 10 is shown having the pressure balanced torsion system 11 according to the present invention incorporated therein. As
15 generally shown in Figure 2, the torsion system according to the present invention comprises a plurality of pairs of upper pressure bearing plates 12 and lower pressure bearing plates 13. These pressure bearing plates may be made of a rigid sheet material such as plastic, sheet metal, fibre board or wood
20 board. Each pair of the pressure bearing plates 12 and 13 is coupled to a torsion spring assembly which consists of two substantially V-shaped elongated torsion springs 14 and 15. Each of these torsion springs has a longer arm 16 and a shorter arm 17 as best shown in Figure 3. The free end of the
25 shorter arm 17 is provided with a short right angled portion 18 which is pivotally coupled to the rear surface of the pressure bearing plate. The free end of the longer arm 16 is provided with a right angled end portion 19 which is pivotally mounted to a rocker member 20 as shown in Figure 2. The rocker
30 member 20 has a semi-circular shape as best shown in Figures 4, 5 and 6. A transverse through opening 21 is formed in the middle thereof, and two cross openings 22 and 23 extend perpendicular to the transverse through opening 21 from the

SUBSTITUTE SHEET

arcuate edge to the flat edge therein for coupling with the right angled end portion of the torsion springs 14 and 15. The rocker member 20 is pivotally mounted on a U-shaped bracket 24 which, in turn, is mounted fixedly to the back plate 25. The plurality of upper pressure bearing plates 12 are secured to a flexible retaining sheet 26 such as by adhesive. The plurality of lower pressure bearing plates 13 are secured to another flexible retaining sheet 27 in the similar manner.

As generally shown in Figure 1 the seat 10 may be provided with three such pressure balanced torsion assemblies, and the entire over all assembly is covered by an external foam-like flexible covering sheet 28.

The operation of the pressure balanced torsion system will now be described with reference to the schematic diagram shown in Figure 8. In the normal condition, the pressure bearing plates 12 and 13 are in the positions shown by the solid lines. However, when an external pressure is applied to the lower pressure plate 13, for example, as shown by the solid arrows 29 such as applied by a human body resting against the pressure bearing plate 13, it will cause the lower pressure bearing plate 13 to move to the second position as shown by the dotted lines against the reactive torsion force of the spring 15. The distance travelled depends upon the degree of the pressure applied onto the pressure bearing plate 13. Also, it will cause the entire torsion assembly to pivot relative to the rocker member 20, thus resulting in pushing the upper pressure bearing plate 12 to move to the dotted line position from the solid line position. The upper pressure bearing plate 12 will then press outwards to abut the area of the human body opposite to such location, while the same location of the human body may also be exerting a pressure on the pressure bearing plate 12 against the torsion force of the spring 14. In this manner, the entire system acting and

SUBSTITUTE SHEET

reacting to the external pressure will eventually come to a stable position in which the external force and the reactive torsion force will be balanced to each other to maintain both the upper and lower pressure bearing plates 12 and 13 pressure
5 intimately against the human body with a same amount of force to provide a comfortable full support therefor.

It can be appreciated by those skilled in the art that the torsion assembly will react quickly to the changing movement of the human body to maintain always a balanced
10 reactive pressure against the entire area of the human body in contact with the system and to conform fully with the body contour.

The operation and reaction of the system may be further improved by the addition of a second level torsion assembly 30
15 located between the upper and lower torsion assemblies and the back plate 25. The second level torsion assembly 30 is similar in construction to the upper and lower torsion assemblies. The rocker member 20 of the upper torsion assembly is pivotally mounted to the free end of the upper torsion spring 31, and
20 the rocker member 20 of the lower torsion assembly is pivotally mounted to the free end of the lower torsion spring 32 therein. The rocker member 33 of the second level torsion assembly is then pivotally mounted to the back plate 25 by the U-shaped bracket 34. In such construction the second level
25 torsion assembly 30 will cooperate with the primary torsion assemblies to provide a softer but smoother reactive torsion support to the body resting against it.

Obviously, numerous modifications and variations of the present invention are possible in light of the above
30 teachings. It is therefore to be understood that within the scope of the appended claims, the invention may be practised otherwise than as specifically described above. For example, the torsion spring may have various configurations as shown in

Figures 11, 12 and 13. As shown in Figure 11, a coil 35 may be formed in the torsion springs 14 and 15 so as to provide a stronger reactive torsion force therein. Also, the free ends of the springs 14 and 15 may be bent 90 degrees to provide a right-angled end portion which can be expeditiously and pivotally mounted to a sleeve portion 36 provided at the rear surface of the pressure bearing plates 12 and 13. The torsion springs may be flat springs such that their free ends may be conveniently secured to the pressure bearing plates with securing clamps 37 as best shown in Figure 12. As shown in Figure 13, the spring may be in the form of a single torsion spring having a coil formed at its middle. The rocker member 20 may then be provided by a round disc forced fitted at the coil. Furthermore, the single torsion spring may be in the form of a substantially C-shaped plate type torsion spring as best shown in Figure 14. In such embodiment, the pressure bearing plates may be eliminated, if the plate type torsion spring has a relatively large width, so that the free end portions of the spring can serve directly as the pressure bearing plates. Also, the rocker member may be in the form of a disc or sleeve mounted on the spring.

The claims defining the invention are as follows:

1. A pressure balanced torsion system for use in a backrest and the like, comprising

a first pressure bearing plate means and a second pressure bearing plate means, each of
said first pressure bearing plate means and second pressure bearing plate means having a front
5 surface and a rear surface opposite to said front surface,

an elongated torsion spring means including a first arm portion having a free end
mounted to said rear surface of said first pressure bearing plate means, and a second end
mounted to one side of a rocker member, said torsion spring means including a second arm
portion having a free end mounted to said rear surface of said second pressure bearing plate
10 means, and a second end mounted to a second side of said rocker member, said second side of
said rocker member being directly located opposite to said one side,

said rocker member being pivotally mounted on a support plate.

2. A pressure balanced torsion system according to Claim 1 including a first sleeve means
disposed on said rear surface of said first pressure bearing plate means, and said free end of
15 said first arm portion of said torsion spring means being pivotally mounted to said first sleeve
means,

a second sleeve means disposed on said rear surface of said second pressure bearing
plate means, and said free end of said second arm portion of said torsion spring means being
pivotally mounted to said second sleeve means.

20 3. A pressure balanced torsion system according to Claim 1 including a bracket member
mounted between said rocker member and said fixed support plate, and said torsion spring
means is a flat spring having two flat surfaces.



4. A pressure balanced torsion system according to Claim 1 wherein said torsion spring means has a coil configuration formed at a middle portion therein, and said rocker member is a round disc secured at said middle portion.

5 5. A pressure balanced torsion system according to Claim 1 wherein said bracket member is a U-shaped bracket mounted fixedly to said support plate.

6. In a human body support device having a plurality of pressure balanced torsion means mounted on a substantially
10 rigid support means, said torsion means comprising,

a U-shaped bracket member mounted on said support means,
a rocker member pivotally mounted on said U-shaped
bracket member, said rocker member having one side and a
second side, and said rocker member being pivotal from said
15 one side to said second side relative to said bracket member,

a first pressure bearing plate means having a front
surface and a rear surface located opposite to said front
surface,

a second pressure bearing plate means having a front
20 surface and a rear surface located opposite to said front
surface,

an elongated torsion spring means having a first arm
portion with a free end therein pivotally mounted to said rear
surface of said first pressure bearing plate means, and a
25 second end therein mounted to said one side of said rocker
member, said torsion spring means having a second arm portion
with a free end therein pivotally mounted to said rear surface
of said second pressure bearing plate means, and a second end
therein mounted to said second side of said rocker member.

30 7. A human body support system according to Claim 6
including a first flexible retaining means attached to said
front surface of said first pressure bearing plate means, and
a second flexible retaining means attached to said front

surface of said second pressure bearing plate means.

8. A human body support system according to Claim 7 including an external covering means disposed over said torsion means and said rigid support means.

9. A human body support system according to Claim 8 wherein said flexible retaining
5 means and said external covering means are made of a resilient foam-like material.

10. A human body support system according to Claim 9 wherein at least two torsion means are mounted to said rigid support means, said torsion means having a plurality of U-shaped bracket members of an individual pair of first pressure bearing plate means and second pressure bearing plate means.

10 11. A human body support system according to Claim 10 wherein said two torsion means comprising an upper torsion means, and a lower torsion means located below said upper torsion means.

12. A human body support system according to Claim 11 including a second elongated torsion spring means located between said two torsion means and said rigid support means,
15 said second elongated torsion spring means having a first arm portion with a free end therein pivotally mounted to said U-shaped bracket member for a pair of first pressure bearing plate means and second pressure bearing pressure plate means in said upper torsion means, and a second and therein mounted to one side of a additional rocker member, said rocker member being mounted to said rigid support means, said second elongated torsion spring means
20 including a second arm portion having a free end therein pivotally mounted to said U-shaped bracket member for a pair of first pressure bearing plate means and second pressure bearing plate means in said lower torsion means, and second end therein secured to said additional rocker member at a side therein opposite to said one side.

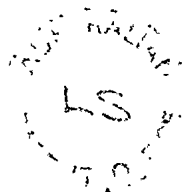

13. A pressure balanced torsion system according to Claim 3 including a flexible retaining sheet means covering over and secured to the front surface of said first pressure bearing plate means and said second pressure bearing plate means.

14. A pressure balanced torsion system for use in a backrest and the like, comprising

5 a plurality of torsion balanced means located between a flexible retaining sheet means and a fixed support plate,

each of said torsion balanced means including a first pressure bearing plate means and a second pressure bearing plate means, each of said first pressure bearing plate means and second pressure bearing plate means having a front surface and a rear surface located opposite

10 to said front surface, an elongated torsion spring means including a first arm portion having a free end therein pivotally mounted to said rear surface of said first pressure bearing plate means, and second end therein mounted to one side of a rocker member, said torsion spring means including a second arm portion having a free end therein pivotally mounted to said rear surface of said second pressure bearing plate means, a second end therein mounted to a
15 second side of said rocker member, said second side of said rocker member being directly located opposite to said one side, and said rocker member being pivotally mounted on said fixed support plate.

15. A pressure balanced torsion system according to Claim 14 wherein the front surfaces of said first pressure plate means and said second pressure bearing plate means are secured to
20 said flexible retaining means by adhesion.

16. A pressure balanced torsion system according to Claim 15 wherein said flexible retaining means is a foam sheet material, and said fixed support plate is a rigid board.

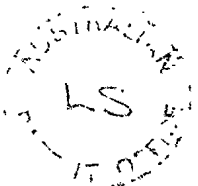

17. A pressure balanced torsion system substantially as hereinbefore described with reference to any one or more of the drawings.

2
3
4
5
6



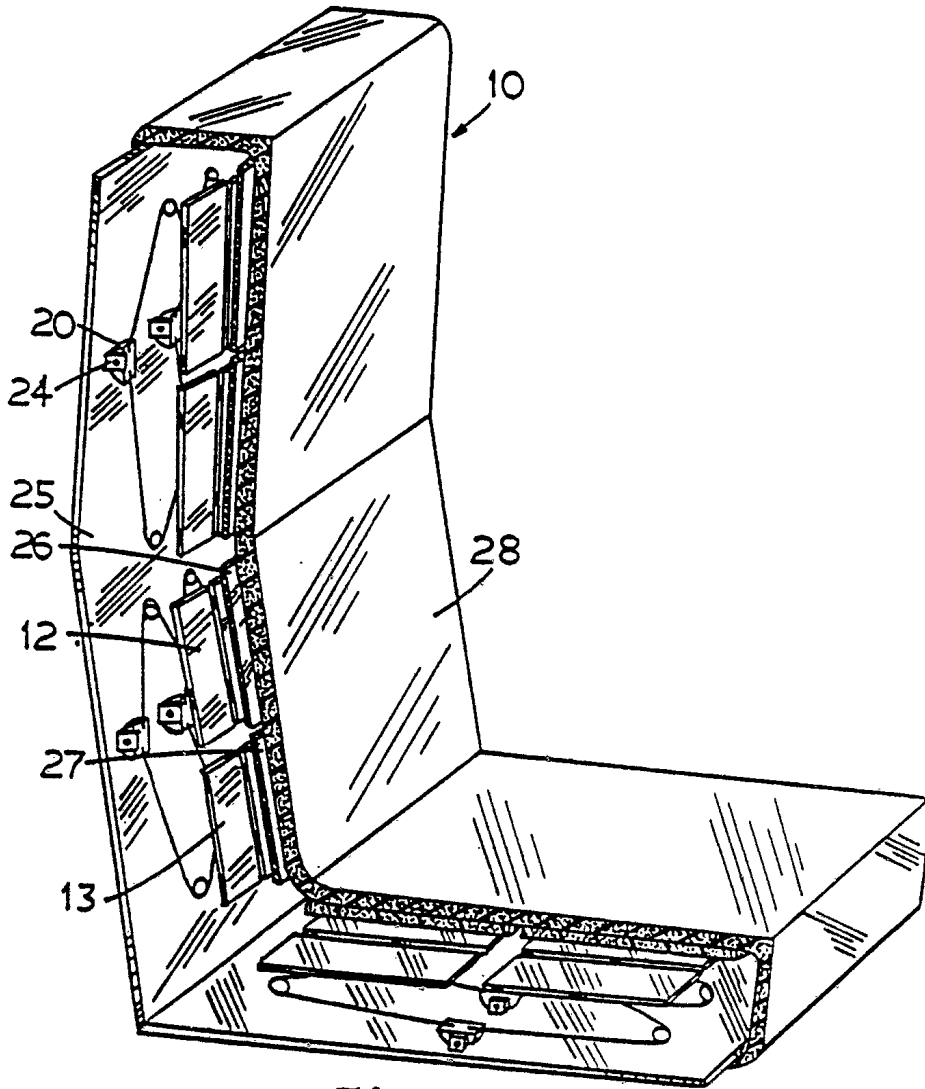

Fig. 1.

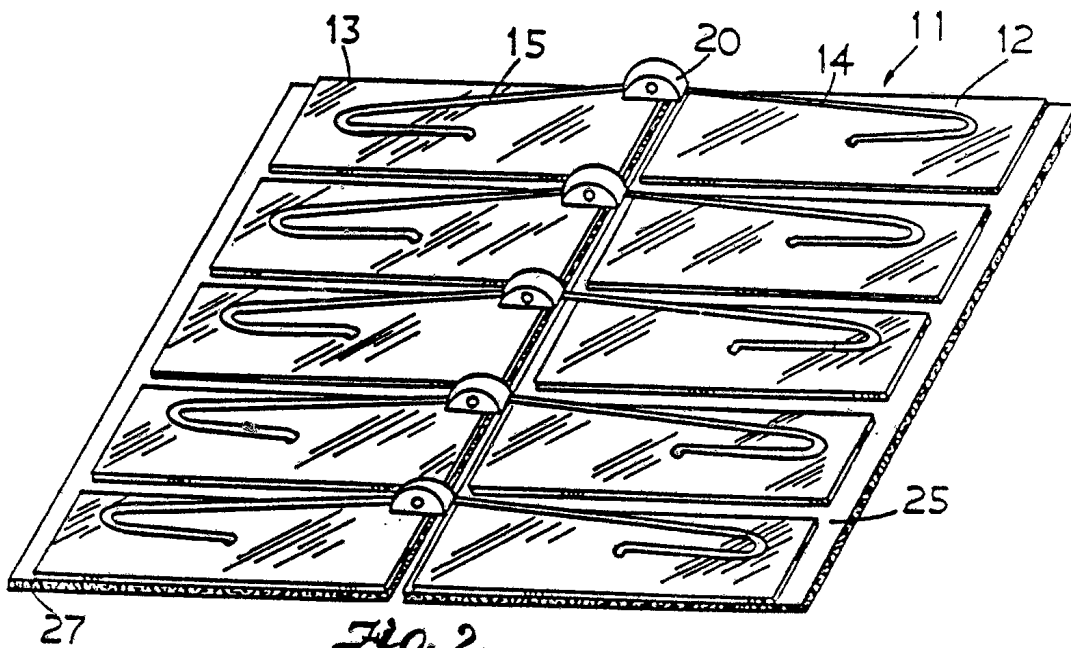
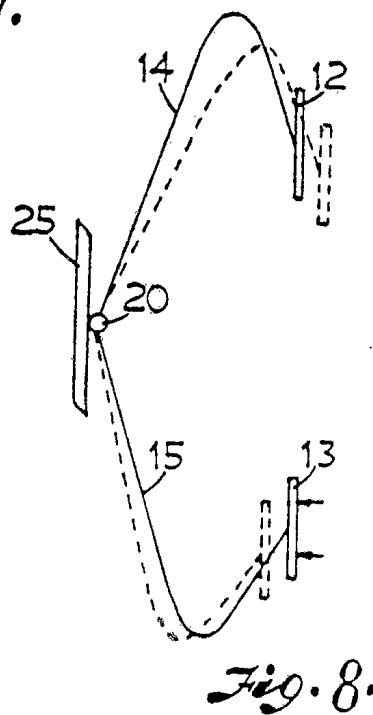
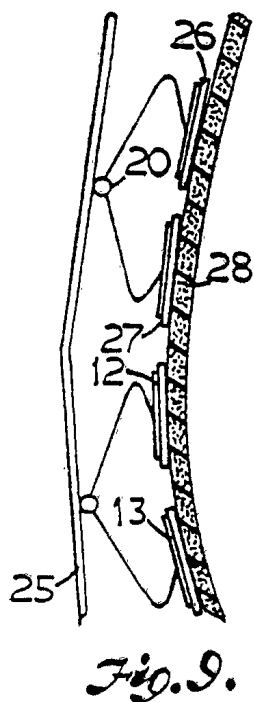
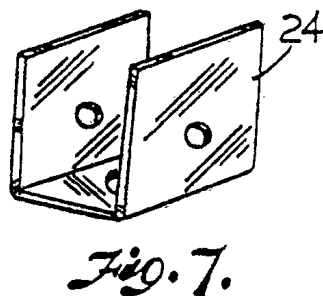
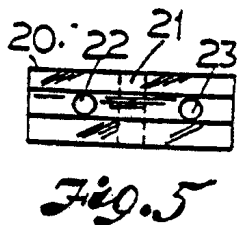
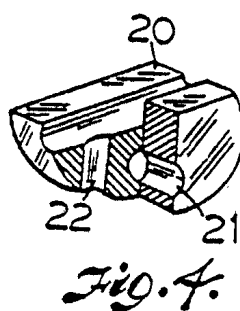
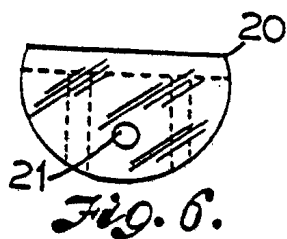
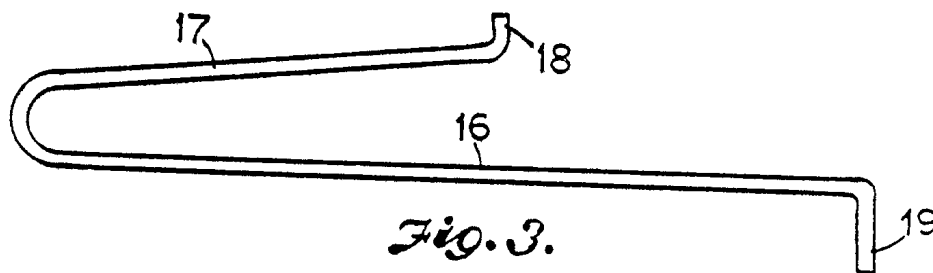

Fig. 2.

SUBSTITUTE SHEET



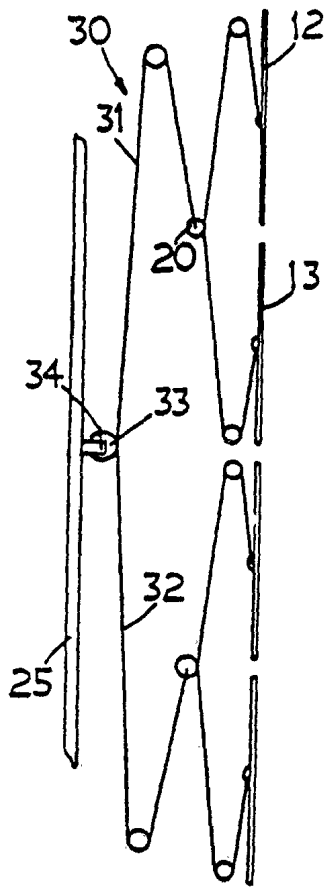

Fig. 10.

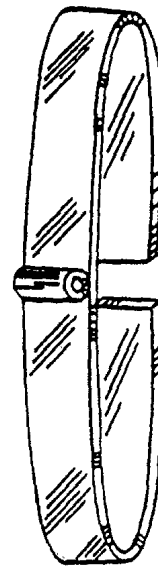

Fig. 14.

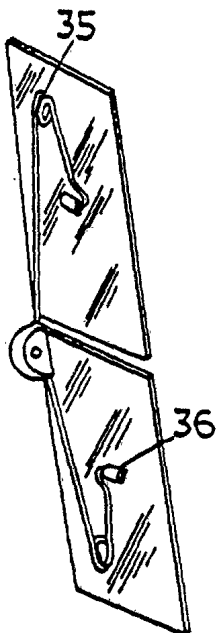

Fig. 11.

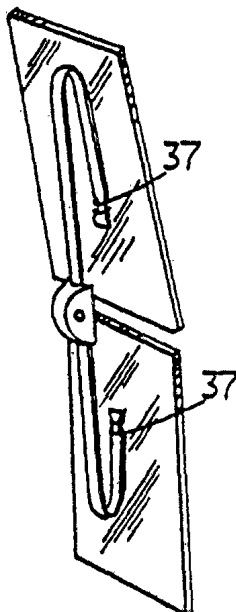

Fig. 12.

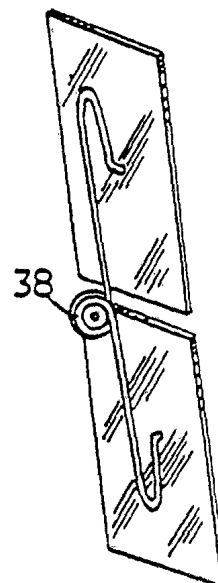

Fig. 13.

INTERNATIONAL SEARCH REPORT

PCT/CA 92/00312

International Application No

I. CLASSIFICATION OF SUBJECT MATTER (if several classification symbols apply, indicate all) ⁶		
According to International Patent Classification (IPC) or to both National Classification and IPC Int.Cl. 5 A47C7/24; A47C23/00		
II. FIELDS SEARCHED		
Minimum Documentation Searched ⁷		
Classification System	Classification Symbols	
Int.Cl. 5	A47C	
Documentation Searched other than Minimum Documentation to the Extent that such Documents are Included in the Fields Searched ⁸		
III. DOCUMENTS CONSIDERED TO BE RELEVANT⁹		
Category ¹⁰	Citation of Document, ¹¹ with indication, where appropriate, of the relevant passages ¹²	Relevant to Claim No. ¹³
A	US,A,2 293 323 (VIALL ET AL.) 18 August 1942 see the whole document -----	1,6,13
A	DE,C,672 258 (SADGROVE) 9 February 1939 see page 3, line 73 - line 80; figure 3 -----	1,6,13
A	DE,A,3 234 755 (MÖBELWERK LIPP OHG) 31 March 1983 see page 11, line 8 - page 15, line 17; figures 1,3,5,7 -----	1,6,13
A	US,A,4 326 311 (PARIPOVICH) 27 April 1982 see figures 5-8 -----	4
<p>¹⁰ Special categories of cited documents:</p> <p>"A" document defining the general state of the art which is not considered to be of particular relevance</p> <p>"E" earlier document but published on or after the international filing date</p> <p>"L" document which may throw doubts on priority claim(s) or which is cited to establish the publication date of another citation or other special reason (as specified)</p> <p>"O" document referring to an oral disclosure, use, exhibition or other means</p> <p>"P" document published prior to the international filing date but later than the priority date claimed</p> <p>"T" later document published after the international filing date or priority date and not in conflict with the application but cited to understand the principle or theory underlying the invention</p> <p>"X" document of particular relevance; the claimed invention cannot be considered novel or cannot be considered to involve an inventive step</p> <p>"Y" document of particular relevance; the claimed invention cannot be considered to involve an inventive step when the document is combined with one or more other such documents, such combination being obvious to a person skilled in the art.</p> <p>"&" document member of the same patent family</p>		
IV. CERTIFICATION		
Date of the Actual Completion of the International Search	Date of Mailing of this International Search Report	
23 SEPTEMBER 1992	02. 11. 92	
International Searching Authority	Signature of Authorized Officer	
EUROPEAN PATENT OFFICE	MYSLIWETZ W.P.	

**ANNEX TO THE INTERNATIONAL SEARCH REPORT
ON INTERNATIONAL PATENT APPLICATION NO. CA 9200312
SA 62433**

This annex lists the patent family members relating to the patent documents cited in the above-mentioned international search report. The members are as contained in the European Patent Office EDP file on
The European Patent Office is in no way liable for these particulars which are merely given for the purpose of information. 23/09/92

Patent document cited in search report	Publication date	Patent family member(s)	Publication date
US-A-2293323		None	
DE-C-672258		None	
DE-A-3234755	31-03-83	None	
US-A-4326311	27-04-82	None	

EPO FORM P007

For more details about this annex : see Official Journal of the European Patent Office, No. 12/82