

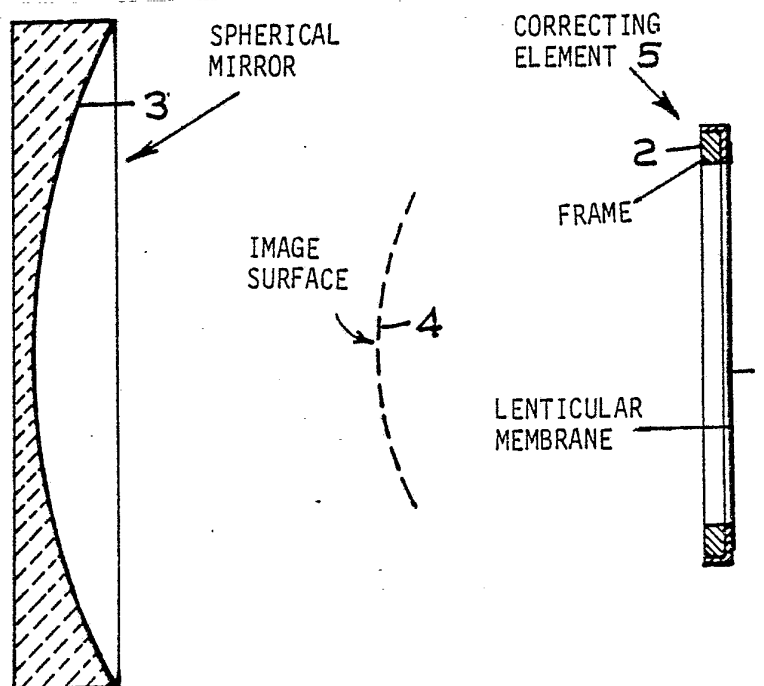

INTERNATIONAL APPLICATION PUBLISHED UNDER THE PATENT COOPERATION TREATY (PCT)

<p>(51) International Patent Classification³ : G02B 1/04, 1/10, 3/02 G02B 5/10, 13/18</p>	<p>A1</p>	<p>(11) International Publication Number: WO 85/ 00060 (43) International Publication Date: 3 January 1985 (03.01.85)</p>
<p>(21) International Application Number: PCT/AU84/00102 (22) International Filing Date: 12 June 1984 (12.06.84) (31) Priority Application Number: PF 9816 (32) Priority Date: 15 June 1983 (15.06.83) (33) Priority Country: AU (71)(72) Applicant and Inventor: JONES, Neal, Keith [AU/AU]; 88 Gladstone Road, Brighton, S.A. 5048 (AU). (74) Agent: COLLISON & CO.; 97 King William Street, Adelaide, S.A. 5000 (AU). (81) Designated States: AT (European patent), AU, BE (European patent), CH (European patent), DE (European patent), FR (European patent), GB (European patent), JP, LU (European patent), NL (European patent), SE (European patent), SU, US.</p>		<p>Published <i>With international search report.</i></p>

(54) Title: THIN PLASTIC CORRECTOR LENSES FOR OPTICAL SYSTEMS



(57) Abstract

An optical correcting element using a lenticular membrane (1) stretched on a frame (2) the membrane being of a thickness less than that required to be self-supporting whereby radiation is passed even though material in a self-supporting form would obstruct the radiation, the correcting element (1, 2) being associated with a spherical mirror (3) or any form of mirror or lens and being independent or adhered to the surface of a mirror or lens.

FOR THE PURPOSES OF INFORMATION ONLY

Codes used to identify States party to the PCT on the front pages of pamphlets publishing international applications under the PCT.

AT	Austria	KR	Republic of Korea
AU	Australia	LI	Liechtenstein
BE	Belgium	LK	Sri Lanka
BG	Bulgaria	LU	Luxembourg
BR	Brazil	MC	Monaco
CF	Central African Republic	MG	Madagascar
CG	Congo	MR	Mauritania
CH	Switzerland	MW	Malawi
CM	Cameroon	NL	Netherlands
DE	Germany, Federal Republic of	NO	Norway
DK	Denmark	RO	Romania
FI	Finland	SD	Sudan
FR	France	SE	Sweden
GA	Gabon	SN	Senegal
GB	United Kingdom	SU	Soviet Union
HU	Hungary	TD	Chad
JP	Japan	TG	Togo
KP	Democratic People's Republic of Korea	US	United States of America

1.

"THIN PLASTIC CORRECTOR LENSES FOR OPTICAL SYSTEMS"

- The primary motive for this invention is to facilitate the development of inexpensive optical systems for use in infrared imaging systems. However,
5. the invention could have wider application to optical systems used for other wavelength ranges.

- The invention consists simply of an aberration-correcting optical element which corrects the aberrations of the optical system of which it is a part.
10. The correcting element is in the form of a thin lenticular membrane of mouldable material stretched on a supporting perimeter frame such as a ring, the thickness of the membrane being varied as required to correct the aberrations of the optical system.
15. The correcting element may be used as a separate element, or alternatively applied to another surface to vary the contour of the surface of the composite element so formed to correct the aberrations of the optical system.
20. The membrane is formed by injection moulding, forging or casting in a mould of which one surface may be optically flat and the other configured to produce the desired variation in membrane thickness.

- Many methods of configuring the master surface of a mould for casting, moulding or forging are well known in the art. Even expensive methods of configuring the master surface could be economic if large numbers of elements are to be formed from a master surface. An advantage is that only one
25. surface of the mould need be configured, the other
- 30.



2.

being optionally an optically flat surface. When stretched the membrane will tend to form two surfaces of equal shape. The thickness variation of the membrane determines the correction of the aberrations.

5. A number of examples of prior art describe methods and means which have some bearing on the invention herein described. For example, Wu (US Patent No. 4,212,836) describes a method for conforming a thin sheet of thermoplastic material to glass
10. surfaces of many different shapes and indeed his method of forming the matching pressing surface could be used to manufacture the configured master surface of the mould to form the herein described corrector lenses, but essentially, Wu does not deli-
15. berately alter the thickness of the sheet, but rather changes the contour of both surfaces of the sheet equally so that the thickness of the sheet remains constant and plays no part in correcting aberrations of the lens surface, whereas in the invention herein
20. described the thickness is varied specifically for correcting aberrations.

- On the other hand N.V. Philips Gloeilampenfabrieken (UK Patent No. 698,772) describe a method of manufacturing a relatively rigid aberration cor-
25. recting plate with an aspheric surface, with a supporting rim which may be reinforced by a metal ring. The rim and ring may not be essential depending on the rigidity of the plate, while the materials listed of which the correcting plate is made would
30. not be suitable to transmit infrared radiation at longer wavelengths. Nor is there any description of using such a plate to modify the contour of another



3.

optical surface to improve the aberration correcting properties of that surface.

In the invention described herein, the correcting lens according to this invention comprises a lenticular membrane stretched on a frame, the membrane being made thin so that materials which in thick sections would block radiation of the required wavelength would be highly transmitting to those wavelengths. The lenticular membrane is thus deliberately made thin and necessarily must be stretched on a ring, which may or may not be reinforced, the ring ensuring that the thin non-selfsupporting membrane maintains a taut configuration necessary to achieve maximum possible definition. As an added advantage materials which are non-rigid even in thick sections, such as rubbers may be employed, thus increasing the range of materials that might be used.

In UK Patent No. 1,295,157 WHITMARSH describes a thin metal sheet or metallised plastic foil stretched on a supporting frame and stretched by the application of air pressure to provide a mirror whose focal length varies with air pressure differential across the foil. The curve so produced is essentially spherical but unless the tension in the foil and its thickness are very uniform indeed, will be subject to local variations in curvature which would affect the optical quality of the images produced thereby. While not a serious problem for the applications cited (dental mirrors, vehicle rear vision mirrors) it may prove difficult to produce surfaces which are sufficiently accurately spherical for the high grade optical systems for which the invention described herein



4.

is addressed. Furthermore, WHITMARSH describes a method of applying air pressure to distort the surface into a spherical surface as a primary imaging device, whereas in the invention herein described, when

5. air pressure is used it is used to distort the aspheric element to facilitate the application of the element to a concave surface.

10. The range of optical materials available for use in infrared optical systems embodying wavelengths greater than 3 μm is severely limited, and practically all those materials are expensive relative to the cost of optical glasses available for use at shorter wavelengths.

15. There are, however, several polymer materials which have useful transmission characteristics at the longer infrared wavelengths, if thin membranes are used, but it is difficult to provide adequate lens power using a thin membrane. One way of achieving a lens effect using a thin membrane is to use a
20. Fresnel lens, as is frequently used in overhead projectors, but the image forming properties of this device are inadequate when high definition images are desired. In this context the invention seeks to approach a system resolution which is limited
25. by diffraction by the aperture of the system.

30. It is desirable, if possible to use curved mirrors since the materials required are readily available and very much less expensive than commonly used infrared optical materials. But for optical systems of high relative aperture (focal length < twice the diameter) and relatively large fields



5.

of view ($>10^\circ$), it is difficult to use more than two mirrors. One therefore resorts to making one or both of the mirrors aspheric, in order to provide the degrees of freedom necessary to correct the aberrations of the system. Indeed two aspheric mirrors are sometimes insufficient in which cases additional aspheric elements of the type described can be conveniently introduced. Also, unless manufactured by replication from a master surface, aspheric surfaces are expensive to produce.

For example an individual correcting element can be applied in a SCHMIDT optical system to provide a wide angle, high relative aperture system with near diffraction limited resolution, for use in an infrared optical system in the wavelength range 8 to 14 μm . The material of the lenticular membrane of the correcting element is typically polyethylene of thickness of the order of 0.3 mm and variation in thickness of the order of 0.1 mm, for a system focal length of 50 mm. In this application much thicker sections of polyethylene prove to be unsatisfactory due to scattering of the radiation in the material by small crystallites resulting in poor transmission and poor imaging quality. The thin correcting element is sufficiently thick to provide adequate mechanical strength not to rupture under tension at its thinnest section; has high transmission, (more than 80%) and sufficiently low scattering not to affect noticeably the imaging properties of the system. Stretching on a supporting frame is essential to ensure a satisfactory optical surface free of buckling and to provide a suitable means for mounting in an optical system.



6.

With lens systems also, aspheric surfaces can reduce the number of components required to provide a given optical definition, thus reducing material cost.

5. As an example of applying a correcting element to another optical surface the formation of a parabolic surface from an easily produced spherical surface was considered. A correcting element formed as described above and with the necessary thickness variation
10. is applied to the spherical surface for which it was designed so forming a parabolic surface. This surface may be coated with metal to form a parabolic mirror, or, if formed on the spherical surface of a transmitting glass element may be used to help
15. correct aberrations of the lens.

This method of course is not confined only to modifying spherical surfaces to parabolic, but can be used to change the forms of other surfaces.

20. The material of which the correcting element is made must be capable of sufficient elongation under stretching not to rupture when curved.

25. Apart from providing an alternative means of supporting the plastic element, application to an optical transmitting lens element reduces reflectance losses, especially if the refractive indices are matched, because reflection at the two surfaces brought into contact is substantially reduced. Thus the process can be used to convert an easily manufactured spherical surface to an aspheric surface,
30. at a much lower manufacturing cost than an equivalent



7.

aspheric lens surface manufactured into the solid lens material.

5. Any means, therefore, of providing aspheric surfaces in an optical system by an inexpensive method of manufacture, would contribute to the development of low cost optical systems.

To enable the invention to be fully understood, embodiments thereof will now be described with reference to the accompanying drawings in which,

10. FIG. 1 shows in section a typical lens assembly embodying the invention when used to correct a mirror,
15. FIG. 2 is a section showing the lens of this invention that is the lenticular membrane being applied to correct a convex lens,
- FIG. 3 is a similar view but showing the lenticular membrane being applied to a concave lens by use of air pressure,
20. FIG. 4 is an enlarged fragmentary section of the edge portion of the lenticular membrane showing how it may be held on the supporting frame by a bonding material, and
25. FIG. 5 is a similar view but showing how the plastic correcting lens can be injection moulded, forged or cast with the components as an integral unit optionally including a metal or other reinforcement ring at the perimeter frame, the membrane being integral with the perimeter frame, a reinforcement ring being shown.
30. Referring now to FIG. 1 this shows a lenticular

8.

5. membrane 1 in the form of a thin lens of polymer stretched under tension on a frame 2 forming a rigid supporting structure. The thickness of the membrane 1 varies as necessary to satisfy the optical requirements of a SCHMIDT optical system in which 3 is a spherical mirror and 4 shows the curved image surface of the system. The lenticular membrane 1 and the frame 2 form the correcting element 5.

10. FIG. 2 shows application of the plastic correcting element 5 to a convex surface 6. The figure shows the lenticular membrane 1 partially in contact with the convex surface 6 during the process of attaching the membrane to the surface.

15. In FIG. 3 the correcting element 5 is applied to a concave surface 9. In this case a means for distending the thin lenticular membrane 1 of the correcting element 5 into a form to fit the concave surface is shown. For example, air pressure is applied through tube 11 to the chamber 12, to make the curvature
20. of the membrane 1 initially greater than that of the concave surface 9 to ensure first contact at the centre and progressive outward displacement of air. Alternatively though less conveniently the membrane 1 could be applied to the concave surface,
25. 9 when the space between the concave surface and the membrane is evacuated.

30. As shown in FIG. 4, a lenticular membrane 1 may be stretched and bonded to the perimeter frame 2 by an adhesive layer 14, or as shown in FIG. 5 it may be injection moulded, forged or cast to have the perimeter of the lenticular membrane 1 integral

9.

with the perimeter frame 12. The metal reinforcement ring 15 is optional.

The invention is not to be limited to these forms of construction.

5. Of course, although primarily invented for use in infrared optical systems, the invention is generally applicable to all optical systems, the application being limited only by the availability of polymeric materials with suitable transmitting and mechanical properties.
- 10.

15. In all cases if necessary, an adhesive can be applied between the lenticular membrane and the supporting surface, such adhesive being selected to transmit the radiation, or alternatively the surfaces can be pretreated before contact either chemically or physically, the treatment depending on the nature of the materials of the contacting surfaces.



10.

THE CLAIMS DEFINING THE INVENTION ARE AS FOLLOWS:

1. An optical correcting element, said correcting element varying in thickness in such a manner to correct at least in part the aberrations of an optical system; characterised by a correcting element in the form of a lenticular membrane of a thickness less than self supporting whereby it will efficiently transmit radiation of the desired wavelength even though the material of which the lenticular membrane is comprised would obstruct the desired radiation if used in thicker section; and a perimeter frame supporting the said lenticular membrane to leave the transmitting portion unobstructed; and said lenticular membrane being held under tension by the said perimeter frame to ensure a stable optical element.
5. 10. 15.
2. A correcting element according to claim 1 applied as an individual optical element in an optical system.
3. A correcting element according to claim 1 adhered to the curved surface of another optical element of said optical system to aid the correction of the aberrations of the whole system, said correcting element being designed to allow for distortion of its lenticular membrane by application to the curved surface to lie on the said surface.
- 5.
4. A correcting element according to claim 3 applied to a concave surface by a gas pressure differential whereby to make the curvature of the lenticular membrane of the correcting element greater than that of the surface to which it is to be applied.
- 5.



11.

5. A correcting element according to claim 3 whose surface is coated to form a mirror.
6. A correcting element according to claim 3 formed by moving the correcting element toward the surface of the said optical element to cause the centre of the said lenticular membrane to first contact the surface of the said optical element at the centre and then progressively outwardly to lie thereon, whereby air is displaced outwardly during the engagement of the lenticular membrane on the said optical element.
7. A correcting element according to claim 6 including the application to at least one contacting surface of an adhesive to bond the said surfaces together.
8. A correcting element according to claim 6 including the chemical or physical treatment of at least one contacting surface to promote adhesion.
9. A correcting element according to claim 1 formed by injection moulding, forging or casting the said lenticular membrane with the said perimeter frame and cooling, whereby the said lenticular membrane is placed into tension.
5. 10. A correcting element according to claim 1 formed by bonding the said lenticular membrane while under tension on to the said perimeter frame.
11. A correcting element according to any preceding claim in which the material of which the correcting element is comprised is polyethylene to transmit



12.

infrared radiation in the waveband 8 μm to 14 μm .

12. A correcting element constructed substantially as described and illustrated in the accompanying drawings.



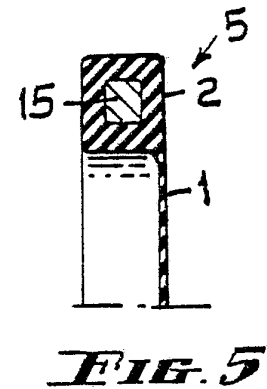
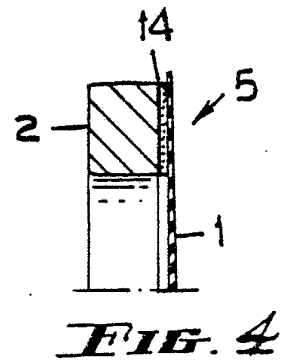
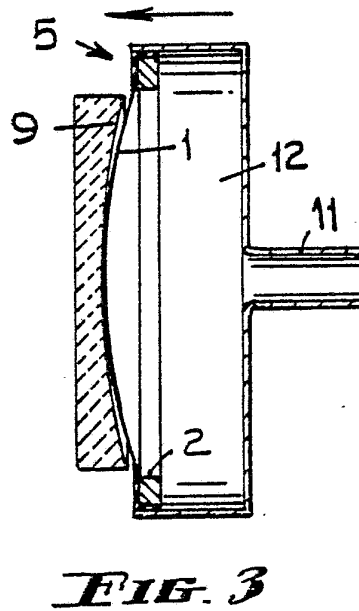
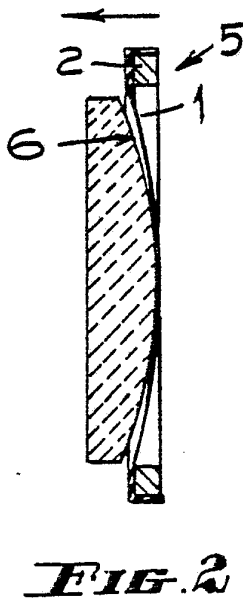
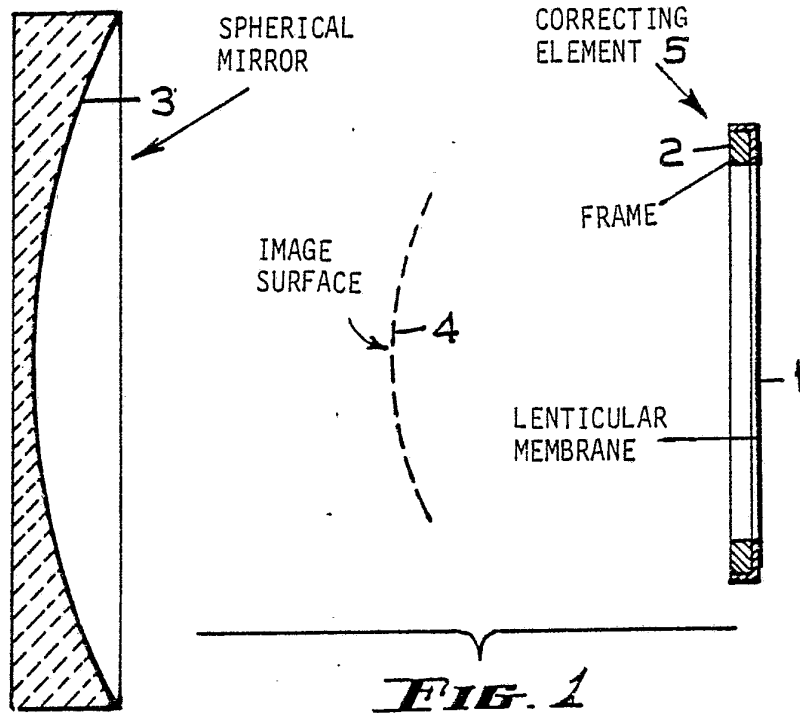

INTERNATIONAL SEARCH REPORT

International Application No PCT/AU 84/00102

I. CLASSIFICATION OF SUBJECT MATTER (if several classification symbols apply, indicate all) ³		
According to International Patent Classification (IPC) or to both National Classification and IPC		
Int. Cl. ³ G02B 1/04, 1/10, 3/02, 5/10, 13/18		
II. FIELDS SEARCHED		
Minimum Documentation Searched ⁴		
Classification System	Classification Symbols	
IPC	G02B 1/04, 1/10, 3/02, 5/10, 13/18, B29D 11/00	
Documentation Searched other than Minimum Documentation to the Extent that such Documents are included in the Fields Searched ⁵		
AU: IPC as above, Australian Classification 00.4		
III. DOCUMENTS CONSIDERED TO BE RELEVANT ¹⁴		
Category [*]	Citation of Document, ¹⁸ with indication, where appropriate, of the relevant passages ¹⁷	Relevant to Claim No. ¹⁹
A	US,A, 3876734 (HOWDEN) 8 APRIL 1975 (08.04.75)	
A	US,A, 3893750 (D'AMATO) 8 JULY 1975 (08.07.75)	
A	US,A, 3917766 (HOWDEN) 4 NOVEMBER 1975 (04.11.75)	
A	US,A, 3922327 (HOWDEN) 25 NOVEMBER 1975 (25.11.75)	
A	US,A, 4196961 (WALTER et al) 8 APRIL 1980 (08.04.80)	
A	US,A, 4212836 (WU) 15 JULY 1980 (15.07.80)	
A	GB,A, 666858 (N.V. PHILIPS' GLOEILAMPENFABRIEKEN) 20 FEBRUARY 1952 (20.02.52)	
A	GB,A, 698772 (N.V. PHILIPS' GLOEILAMPENFABRIEKEN) 21 OCTOBER 1953 (21.10.53)	
A	GB,A, 1129539 (RADIO CORPORATION OF AMERICA) 9 OCTOBER 1968 (09.10.68)	
A	GB,A, 1295157 (INITIAL PLASTICS LIMITED) 1 NOVEMBER 1972 (01.11.72)	
A	GB,A, 1301551 (MULLARD LIMITED) 29 DECEMBER 1972 (29.12.72)	
A	GB,A, 1343164 (MULLARD LIMITED) 9 JANUARY 1974 (09.01.74)	
<p>[*] Special categories of cited documents: ¹⁵</p> <p>"A" document defining the general state of the art which is not considered to be of particular relevance</p> <p>"E" earlier document but published on or after the international filing date</p> <p>"L" document which may throw doubts on priority claim(s) or which is cited to establish the publication date of another citation or other special reason (as specified)</p> <p>"O" document referring to an oral disclosure, use, exhibition or other means</p> <p>"P" document published prior to the international filing date but later than the priority date claimed</p> <p>"T" later document published after the international filing date or priority date and not in conflict with the application but cited to understand the principle or theory underlying the invention</p> <p>"X" document of particular relevance; the claimed invention cannot be considered novel or cannot be considered to involve an inventive step</p> <p>"Y" document of particular relevance; the claimed invention cannot be considered to involve an inventive step when the document is combined with one or more other such documents, such combination being obvious to a person skilled in the art.</p> <p>"&" document member of the same patent family</p>		
IV. CERTIFICATION		
Date of the Actual Completion of the International Search ²	Date of Mailing of this International Search Report ²	
3 August 1984 (03.08.84)	<i>15 August 1984 (15-8-1984)</i>	
International Searching Authority ¹	Signature of Authorized Officer ²⁰	
Australian Patent Office	A.S. MOORE <i>A.S. Moore</i>	

ANNEX TO THE INTERNATIONAL SEARCH REPORT ON
INTERNATIONAL APPLICATION NO. PCT/AU 84/00102

This Annex lists the known "A" publication level patent family members relating to the patent documents cited in the above-mentioned international search report. The Australian Patent Office is in no way liable for these particulars which are merely given for the purpose of information.

Patent Document
Cited in Search
Report

Patent Family Members

US 3876734	DE 2238416 JP 48026149	FR 2148555	GB 1362993
------------	---------------------------	------------	------------

US 3893750	AU 68458/74 CA 1016377 GB 1472926 NL 7405487	BE 814360 DE 2421255 IT 1010922	BR 7403501 FR 2228229 JP 50016549
------------	---	---------------------------------------	---

US 3917766	DE 2254370 JP 48060936	FR 2161111 US 3980399	GB 1362380
------------	---------------------------	--------------------------	------------

US 3922327	DE 2355091 JP 49084260	FR 2221408	GB 1364393
------------	---------------------------	------------	------------

US 4196961	DE 2622113 JP 52141242	FR 2352314 SE 7705784	GB 1581183
------------	---------------------------	--------------------------	------------

GB 1295157	FR 2107822		
------------	------------	--	--

GB 1343164	DE 2238970	FR 2148557	JP 48026150
------------	------------	------------	-------------

END OF ANNEX