

H. H. CUMMINGS.
LASTING MACHINE.

APPLICATION FILED MAY 2, 1900.

NO MODEL.

4 SHEETS—SHEET 2.

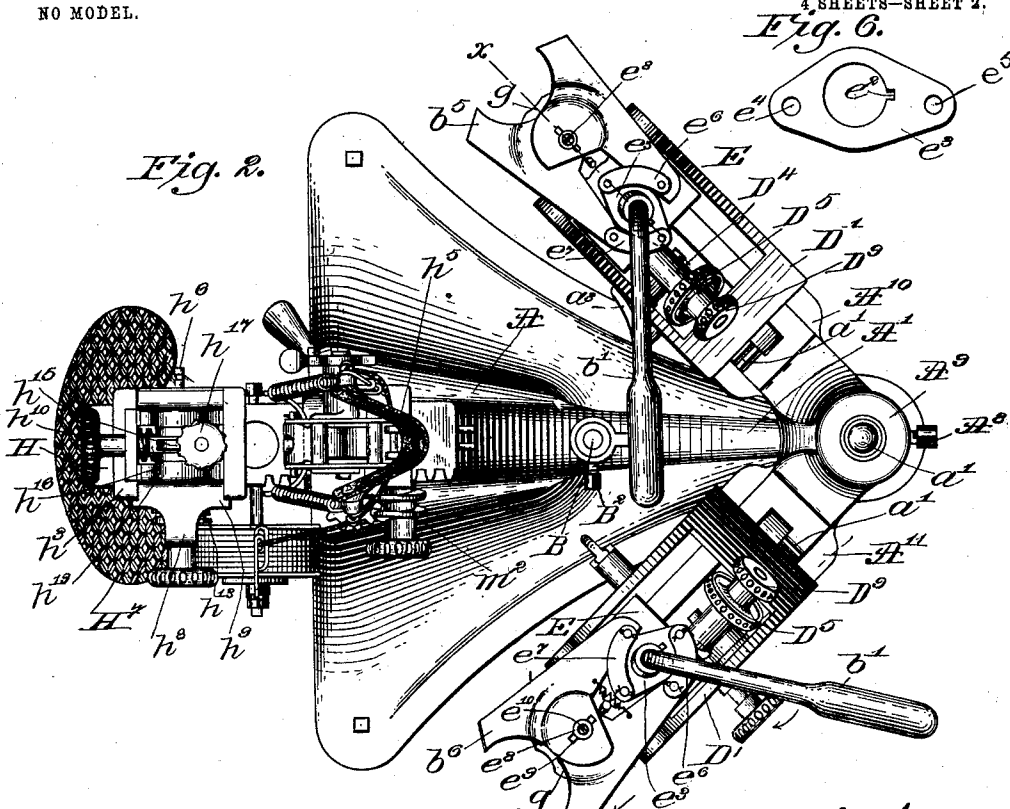

Fig. 2.

Fig. 6.

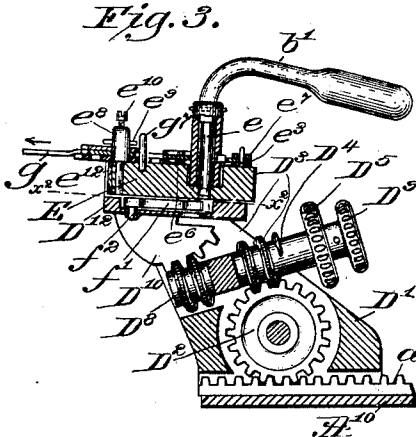

Fig. 3.

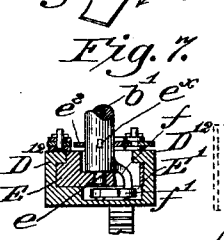

Fig. 7.

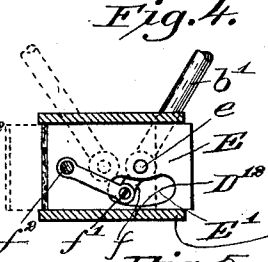

Fig. 4.

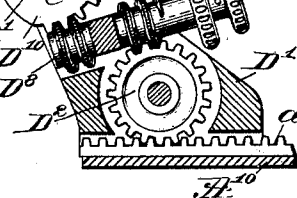

Fig. 8.

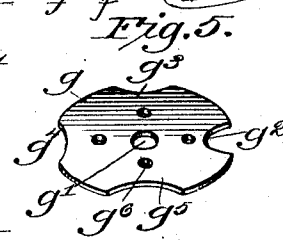

Fig. 5.

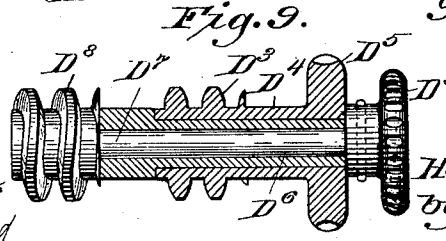

Fig. 9.

Witnesses:
Frank G. Hattie.
W. C. Simmsford

Inventor:
Henry H. Cummings,
by Lewis & Gregory
Attys.

H. H. CUMMINGS.
LASTING MACHINE.

APPLICATION FILED MAY 2, 1900.

NO MODEL.

4 SHEETS—SHEET 3.

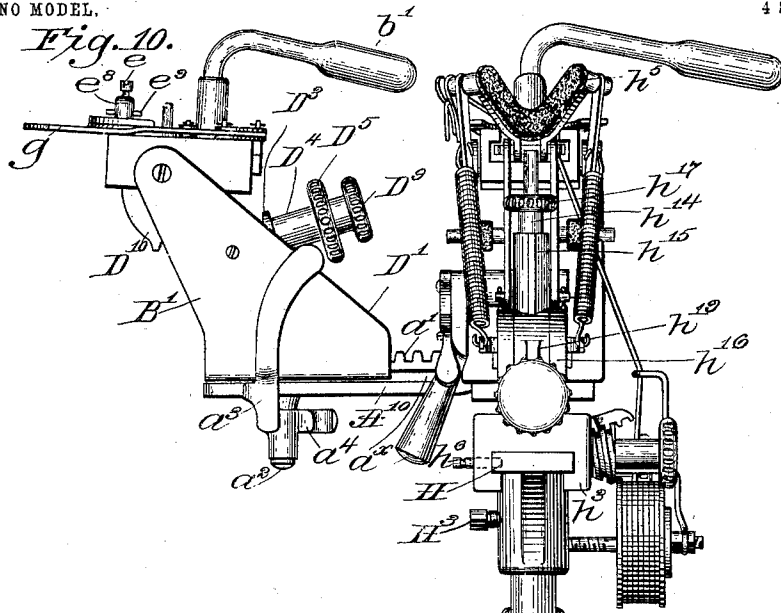

Fig. 11.

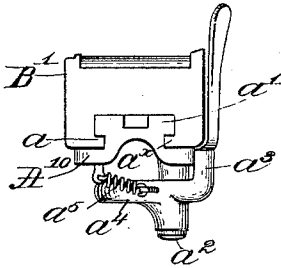

Fig. 12.

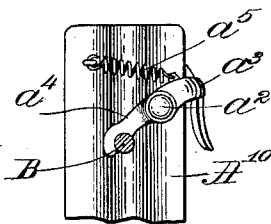

Fig. 13.

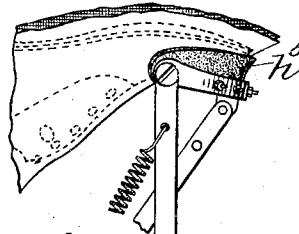
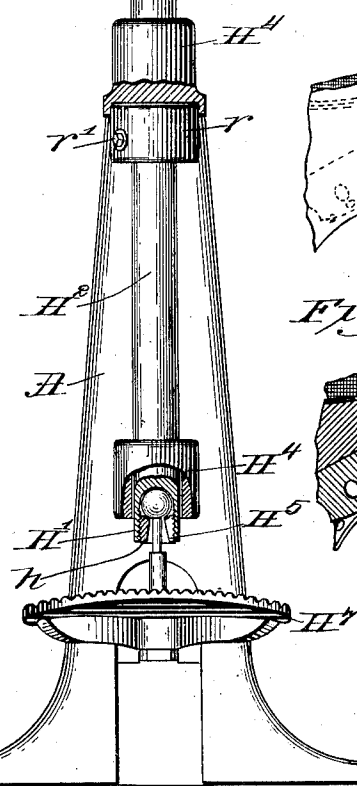
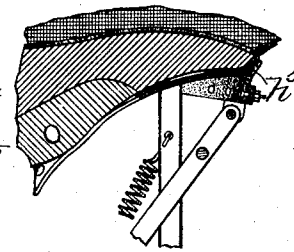

Fig. 14.



Witnesses:
 Frank G. Hettie
 W. C. Sunsford.

Inventor,
 Henry H. Cummings
 by Crosby & Gregory Attys.

H. H. CUMMINGS.
LASTING MACHINE.

APPLICATION FILED MAY 2, 1900.

NO MODEL.

4 SHEETS—SHEET 4.

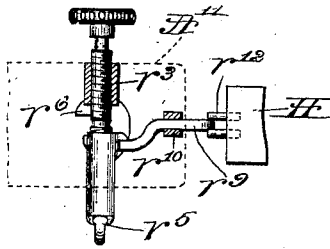
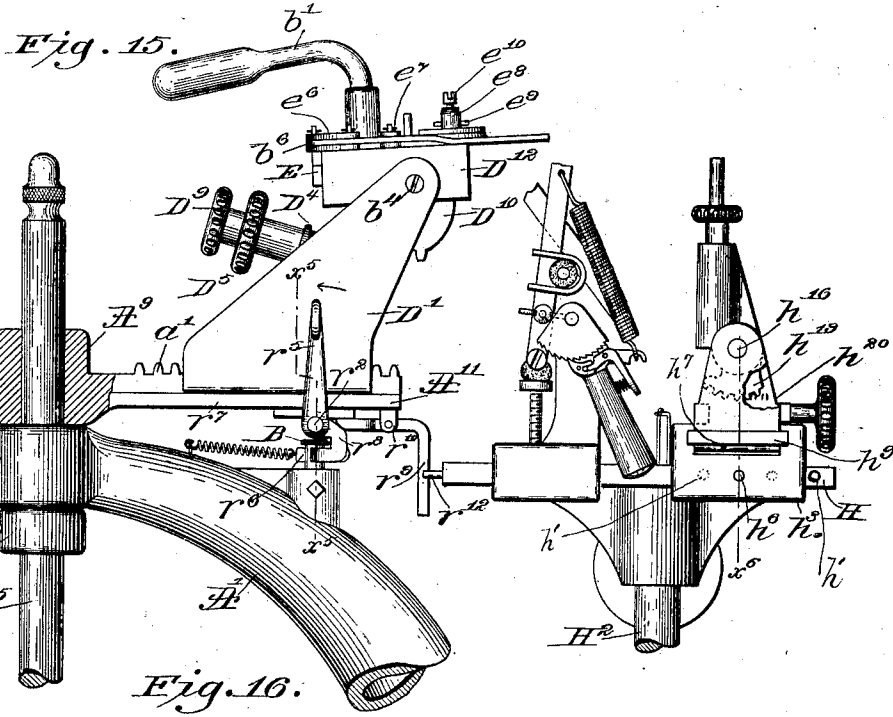

Fig. 18.

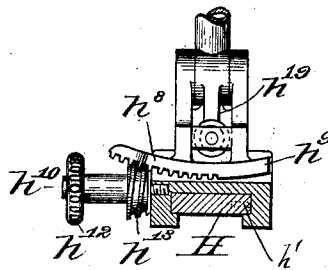
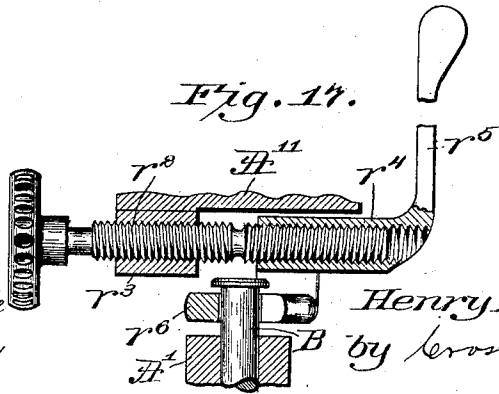

Fig. 19.



Witnesses:
 Frank G. Hattie
 W. C. Samsford

Inventor:
 Henry H. Cummings,
 by Crosby & Gregory
 Attys.

UNITED STATES PATENT OFFICE.

HENRY H. CUMMINGS, OF MALDEN, MASSACHUSETTS, ASSIGNOR TO PEER-
LESS MACHINERY COMPANY, OF CHARLESTON, WEST VIRGINIA.

LASTING-MACHINE.

SPECIFICATION forming part of Letters Patent No. 737,586, dated September 1, 1903.

Application filed May 2, 1900. Serial No. 15,183. (No model.)

To all whom it may concern:

Be it known that I, HENRY H. CUMMINGS, a citizen of the United States, and a resident of Malden, county of Middlesex, State of Massachusetts, have invented an Improvement in Lasting-Machines, of which the following description, in connection with the accompanying drawings, is a specification, like letters on the drawings representing like parts.

The invention to be herein described relates to the jack which receives and holds the last containing the shoe to be lasted and also to the parts employed to position and actuate the crimping-jaws.

The jack-head is carried at the upper end of a revoluble spindle also free to be slid vertically in its bearings, the lower end of the spindle being connected by a ball-ended link jointed to a foot-treadle normally kept in its elevated position by a strong spring, the strength of which may be readily adjusted by the operator.

The stand carrying the usual toe-wiper may be slid accurately on the head to occupy any desired position by means of a worm toothed pinion mounted in the carriage and engaging worm-teeth cut in the head, a worm on the carriage engaging the teeth of the pinion and turning it as required.

The carriage containing and supporting the last is, for the first time known to me, made adjustable longitudinally on the head. The last-supporting carriage has its base fitted to slide with relation to a guideway of the jack-head, and the carriage has an adjustable sleeve provided with screw-threads with which engage threads of a last-holding pin provided with a hand-wheel whereby the operator may quickly and easily rotate the pin to put it at the proper height and thereby put the sole of the last at the proper level or angle, that the toe-wiper in its movements may be made to engage properly the upper on lasts of varying shape or curvature in fitting the last to the upper.

The body of the last-supporting carriage, sustaining the sleeve referred to, may and preferably will be made in two parts—a foot part and a body part, the body part containing a pivot for the sleeve and having a segmental toothed foot free to be moved in a

guideway in the foot part of the carriage. The body of the carriage is movably sustained by the jack-head.

The teeth of the toothed foot shown are of proper shape to be engaged by the teeth of a worm on a shaft sustained by said carriage.

By rotating the worm the body part of the carriage on which is pivoted the sleeve carrying the last-pin may be tipped in a vertical plane transverse to the length of the last to enable the last-pin of the jack to be suitably inclined with relation to a perpendicular line, that said pin may enter the base of the last and position correctly the bottom of the last even though the base should not be made exactly vertical, or should it have become enlarged by use. The sleeve carrying the last-pin may also be tipped to incline the pin toward or from the toe or heel crimping jaws or devices.

Prior to this invention the carriage having the last-pin to receive the last has been fixed on the head, and all the adjustment to provide for difference in length of lasts has been effected by moving the carriage containing the toe-wiper. By adjusting both carriages toward and from the spindle supporting the head the operator can more readily position the last containing the shoe to be lasted with relation to the crimping-jaws.

The crimping-jaws are pivoted upon a stud rising from a block free to slide in a pivoted bed having sector-teeth engaged by a worm on a shaft mounted in a sliding stand carrying the said jaws, the rotation of said worm turning the bed about its pivot to enable the crimping-jaws to be put in the proper position with relation to the last employed.

The shaft carrying the worm is extended through a bearing having a sleeve surrounded by a hollow sleeve provided with a worm and hand-nut, the worm engaging the teeth of a worm toothed pinion sustained in said sliding stand and engaging worm-teeth formed on an arm of a rocking head, the lower end of said stand having a tongue-and-groove connection with said arm. By rotating the hollow sleeve the stand may be slid back and forth on the arm of the head according to the length of the last.

The block carrying the crimping-jaws is slid

in the pivoted bed and the jaws are closed as the block is moved in one direction and opened when moved in the opposite direction by or through a hand-lever, tubular at its inner end and fitted over a stud in said block, said lever having at its lower end an arm, which is extended through an opening in the block and connected by a link to a stud of the bed. The tubular part of the lever also has keyed upon it a lever to which are pivoted links, in turn jointed to the inner ends of the crimping-jaws. As the hand-lever is turned about the fixed stud of the block, the arm of the lever jointed to one end of the link held at its other end by the bed, results in sliding the block in the bed in one or the other direction, according to the direction in which the lever is turned. When the lever is turned in a direction to slide the block toward the last, the jaws moving with the block are gradually closed to act upon the leather of the upper and overturn it on the inner sole.

Usually in lasting-machines there is a separate toe-crimping plate for each size of last, and when a last of a different size is to be used the crimping-jaws had to be removed in order that a crimping-plate of the proper shape might be put on the machine. Herein I have obviated changing the crimping-plate by providing one plate with a series of recesses of different sizes to cooperate with different sizes or shapes of last, and when a different last is to be used I have only to lift a pin and turn the toe-crimping plate into position to bring into operative position the notch of the proper size.

Figure 1 in side elevation represents a lasting-machine containing the invention to be herein described, the last with the upper and toe-wiper being shown as having been adjusted in proper position preparatory to actuating the toe-wiper to fit the upper to the last. Fig. 2 is a top or plan view of the machine in a different position from that represented in Fig. 1, the last being removed and the heel and toe lasting devices being in their inoperative positions, the head carrying said devices being turned aside to more readily show the stop, which is employed to position the head when either the heel or toe lasting devices are in their operative positions. Fig. 3 is a sectional detail in the irregular line x , Fig. 2. Fig. 4 is an under side view of the block E in the bed D¹³, cut on the line x^2 , Fig. 3, the pin f^2 being in section. Fig. 5 shows the toe-crimping plate detached. Fig. 6 is a detail of the lever detached from the operating-handle. Fig. 7 is a cross-section of the bed and block chiefly to show the arm connected with the link attached to the bed. Fig. 8 shows the block in top view; Fig. 9, an enlarged sectional detail of the two worm-shafts for tipping the bed and sliding the carriage. Fig. 10 is an elevation of the machine viewing it from the left in Fig. 1, the last being omitted and the toe-lasting devices being in their operative positions or the positions

which they will occupy when the toe is being lasted. Fig. 11 is a detail showing that part of the head carrying the carriage on which is mounted the heel-lasting devices, said view being made chiefly to show the locking device carried by said arm. Fig. 12 is an under side view of the parts represented in Fig. 11. Fig. 13 is a detail showing part of a shoe on the last and the toe-wiper as having completed its movement. Fig. 14 is a view similar to Fig. 13, the last and toe-wiper being shown in section to better illustrate the action of the toe-wiper in holding the upper stretched on the last preparatory to drawing the upper by the action of usual pincers. Fig. 15 is a detail looking at Fig. 1 from its rear side. Fig. 16 is an under side view of the arm A¹¹ and its positioning member and locking device for the head H. Fig. 17 is an enlarged sectional detail in the line x^5 , Fig. 15. Fig. 18 is a section in the line x^6 , Fig. 15.

The column A, adapted to stand on the floor, has an extended arm A', provided with a bearing A², and a second extended arm A³, provided with a step A⁴ for a spindle A⁵, which is extended through the bearing A² and is maintained in proper position in said step by a suitable collar A⁶, secured to said spindle by a set-screw A⁷. The spindle above the bearing A² has fixed upon it by a suitable set-screw A⁸ (see Fig. 2) the hub of a rocking head A⁹, having two arms A¹⁰ and A¹¹, said arms carrying, respectively, the heel and toe lasting devices to be described. These arms occupy a position nearly at right angles one to the other, and the head is movable with the spindle A⁵, the head having two working or operative positions, one when the heel is being lasted and the other when the toe is being lasted, and at such time either the arm A¹⁰ or A¹¹ will stand substantially in line with the arm A'.

Fig. 2 shows the head in an inoperative position chiefly to illustrate a stud B, rising from the arm A' and serving as a stop to determine the position of the head during the time that the crimping-jaws are being moved forward over the toe of the upper on the last.

The arms A¹⁰ and A¹¹ are each grooved at its sides a^x , as represented best by the arm A¹⁰ in Fig. 11, to receive a tongue, as a , extended from suitable carriages to be described, carrying the toe and heel crimping jaws, and said arms each have a series of rack-teeth a' at their upper sides. The arm A¹⁰ has a depending stud a^2 , on which is pivoted a locking device a^3 , shown as a lever having its end extended upwardly at the inner side of the carriage B', upon which is mounted the heel-crimping jaws, said locking device having an arm a^4 (see Fig. 12) extended horizontally under the arm A¹⁰ and notched to embrace the stud B, (represented in Fig. 12 as in section in its working position,) the locking device engaging the stud and holding the arm A¹⁰ in the position required while operating the heel-crimping jaws by a right-hand

pull on a hand-lever b' , to be described, a suitable spring a^5 keeping the locking device normally in its position to engage readily the stud B whenever the arm A^{10} is swung into position parallel with the top of the extension A' . The under side of the arm A^{11} is provided (see Figs. 1 and 17) with a depending lug r^6 , carried by the positioning device, which as the arm A^{11} is put into position parallel with the arm A' meets the stop B and acts as an abutment while the operator by a right-hand pull on another like hand-lever b' actuates the toe-lasting devices.

The carriages B' and D' , carrying respectively the heel-lasting and the toe-lasting devices, are substantially alike, so but one need be specifically described. Each arm A^{10} and A^{11} , on which these carriages are fitted to slide, has a like series of teeth a' . Each carriage has (see the carriage D' , Fig. 3) a worm toothed gear, as D^2 , which is engaged by a suitable worm D^3 on a hollow shaft D^4 , having a hand-wheel D^5 , said hollow shaft being sustained on a sleeve D^6 , which constitutes the bearing for a shaft D^7 , having a worm D^8 and a hand-wheel D^9 . Each of the worms D^8 engages worm-teeth at the end of a like sector D^{10} , extended from each of the two like beds D^{12} , pivoted at b^4 between upright ears forming parts of said carriages. By rotating the shaft D^7 the bed may be turned about its pivots to put the acting ends of either of the crimping-jaws b^5 used to crimp the toe and heel at the proper angle with relation to the toe and heel end of the last, that said jaws when moved over either the toe or heel may contact properly therewith. The rotation of the hollow shaft D^4 and its worm working through the gear D^2 adjusts the carriage containing the heel or toe lasting devices longitudinally toward and from the last, and this may be done quickly, the two hand-wheels D^5 and D^9 being arranged closely together, so that the operator with his hand in one position may readily adjust either the bed or the carriage into any desired position.

Each bed D^{12} contains a sliding block E, having made through it from top to bottom an opening E' , (see Figs. 7 and 8,) and at one side of said opening the block has rising from it a stud e . The stud e receives upon it the tubular end of one of the hand-levers b' , the said tubular part having an exterior spline e^x to enter a groove e^2 , (see Fig. 6,) in a lever e^3 , having at its opposite ends suitable holes, as e^4 e^5 . These holes receive suitable pins upon which are pivoted suitable like links e^6 e^7 , in turn jointed to the rear ends of the crimping-jaws b^5 b^6 , said jaws arranged in pairs being mounted to turn about a suitable stud, as e^8 , entering a hole in the block E, said stud having a cross-hole near its upper end in which is inserted a pin e^9 , said pin being locked in working position by a set-screw e^{10} .

The lower end of the sleeve of each of the like hand-levers b' (see Fig. 4) has a like arm, as f , which is extended downwardly through

the slot E' , the lower end of said arm entering a hole in a link f' , the opposite end of said link being pivoted upon a stud f^2 , anchored in the bed D^{12} , (see Fig 3;) Fig. 4 showing the stud in section. With this construction, assuming (see Figs. 2 and 3) that the crimping-jaws are in their inoperative positions, it will be readily understood that by taking hold of either of the handles b' by the right hand and pulling the same toward the front of the machine (the position occupied by the operator) the rotation of either handle will cause the arm f , acting in the link, to slide the block E in the direction of the arrows near said jaws in Figs. 2 and 3, the block taking with it the pair of crimping-jaws, and as the hand-lever is turned the lever e^3 , connected therewith, acting through the links e^6 e^7 , closes the open front ends of the crimping-jaws, the action of the hand-levers causing the crimping-jaws to slide up to meet the upper either at the heel or toe, whichever one is being lasted, the jaws being gradually closed and folding and crimping the upper inwardly, laying the same over upon the bottom of the last or the inner sole thereon in the usual method of toe and heel lasting.

Between the blocks E and the under side of the crimping-jaws I have applied a crimping-plate g . (Shown detached in Fig. 5.) This plate has a central hole g' , which fits the pin e^3 , and the plate has a series of notches g^2 g^3 g^4 g^5 of different sizes, according to the toes of the different lasts containing the uppers to be lasted. The plate has a series of locking-holes g^6 , any one of which may be entered by a suitable removable pin g^7 . When the pin is removed, the operator may readily turn the plate g , bringing that portion of the plate containing the notch of the proper size at the front end of the block E. This notched crimping-plate meets the upper at the extreme toe of the last and pushes it over upon the inner sole of the last just before the crimping-jaws are closed to wipe the upper over from the opposite sides of the toe inwardly upon the inner sole lying on the last.

Heretofore in machines of the class herein described there has been a separate crimping-plate for each size of last used and the jaws had to be removed in order to take off a crimping-plate and substitute another of the proper size for it.

The jack for holding the shoe consists, essentially, of a head H, having a depending sleeve which is fitted over the end of a spindle H^2 and secured thereto by a set-screw H^3 . The spindle enters suitable bearings, as H^4 , carried by the column, and the lower end of the spindle is provided with a socket H' , having screw-threads. (See Fig. 10.) The socket receives the ball-shaped end of a link H^5 , jointed by a pivot H^6 at its lower end to a treadle H^7 , pivoted at H^8 on the column, said treadle having connected with it one end of a spring H^9 , the upper end of said spring being connected to a plate H^{10} , having a suitable

screw-thread which is entered by the shank of a screw H^{12} , having a suitable hand-nut readily accessible by the operator, so that by turning said screw the stress of the spring
 5 may be increased or diminished to suit the requirements of the operator or the work to be done. The threaded end of the socket in the spindle H^2 receives a suitable split union h . (See Fig. 10.)

10 The head H has at one side a series of holes h' , any one of which may receive a locking-stud h^8 , and at its opposite side said head has a series of rack-teeth h^2 . The head is suitably shaped to be embraced by two carriages
 15 h^3 and h^4 , the carriage h^3 sustaining a suitable last-pin, to be described, while the carriage h^4 sustains a toe-wiper h^5 of well-known construction, so that a detailed description of the toe-wiping mechanism is not herein
 20 necessary.

The base of the stand h^3 is grooved to be embraced and be adjusted horizontally upon the head H , (see Fig. 18,) and it may be locked in any of its several adjusted positions by a
 25 suitable stud, as h^6 , passed through a hole in said stand and entering one of the holes h' .

The foot part of the carriage h^3 at a point above the level of the head H is provided with a transverse way or groove h^7 , which receives the segmental toothed base h^8 of the body
 30 part h^9 of the carriage.

The foot part of the carriage h^3 has a suitable stud or pin h^{10} , on which is mounted a hand-operated sleeve h^{12} , provided with a worm
 35 h^{13} , which engages the worm-teeth of the base h^8 , the rotation of the worm causing the last-pin h^{14} , the shank of which enters a sleeve h^{15} , pivoted at h^{16} on the body part, to occupy a position more or less inclined to a
 40 line drawn longitudinally through the head H , to thereby adapt the last-pin to any peculiarity or malformation of the hole in the last being used. The last-pin is threaded at its end entering the sleeve, and the pin has a
 45 hand-wheel h^{17} , which may be engaged by the operator to put the heel end of the last at the proper level, according to the shape of the last and its depth. The lower end of the sleeve h^{15} has a toothed sector h^{19} , (see Fig.
 50 15,) which is engaged by a worm h^{20} on a short worm-shaft, the rotation of the worm h^{20} tipping the sleeve and pin in the direction of the length of the head H . The tipping of the sleeve on its pivot h^{16} also enables the last-pin to properly bind in the hole in the last.
 55

The carriage h^4 has at one side a suitable stud, as m , which receives over it a worm-toothed pinion m' , which is engaged by worm-teeth of a suitable worm m^2 , also mounted in
 60 said carriage, the rotation of said worm turning the pinion and causing its teeth in engagement with the rack-teeth h^2 of the head to adjust the carriage h^4 horizontally and longitudinally of the head to place the toe-wiper h^5
 65 in just the desired position that it will contact with the shoe at exactly the desired point or substantially as represented in Fig.

1, it being thereafter actuated or moved into the position Figs. 13 and 14, during which operation the edge of the toe-wiper, preferably of stiff leather, by contact with the upper on the last stretches the upper in the direction of its length toward the toe, the toe-wiper stopping in the elevated position shown in Figs. 13 and 14 and holding the upper firmly against the toe in position to enable the crimping-plate and the crimping-jaws to approach the upper so held and lay it over the inner sole w , represented in Fig. 14 as lying on the last w' .

Heretofore a carriage carrying a toe-wiper has been adjusted upon the head carrying it; but so far as I am aware a carriage carrying the last-pin has not been so adjusted, and great advantages result from adjusting both of these carriages, as thereby a greater range of sizes of lasts may be readily applied to and held by the jack.

Referring to Fig. 14, it will be seen that the upper does not contact with the hollow part of the top of the last. When the toe-wiper is in the position Figs. 13 and 14, the operator engages the upper by usual pincers and draws it in a direction to strain the upper across the last, and the drawn upper is then tacked to the inner sole. This drawing fits the upper snugly to the entire top of the last. After this and after having laid the edge of the upper immediately at the toe over upon the inner sole and inserted a tack temporarily the crimping-jaws are operated to complete the crimping and laying of the toe end of the upper over the inner sole on the last, and the upper laid over the operator secures the same by suitable tacks. The upward position of the spindle H^2 and the jack is determined by an adjustable collar r , secured to said spindle by a suitable set-screw r' .

The arm A^{10} is provided with a device a^3 , which engages the stud B to lock that arm in its operative position.

I have provided the arm A^{11} , carrying the jaws for crimping the toe with a device, by which said arm and said crimping-jaws may be accurately positioned. This device consists of a screw r^2 , represented as provided with right and left threads, one of said threads engaging screw-threads in a box r^3 , suitably bolted to the arm A^{11} , the screw-threads of opposite pitch entering a threaded sleeve r^4 , connected with a positioning device r^5 , having a hook r^6 , which when the arm A^{11} and the toe-crimping plates are in position may be made to engage the stud B referred to. The acting end r^6 of the positioning device r^5 may be moved rapidly in one or the other direction by turning the screw-shaft r^2 , it sliding the sleeve r^4 .

To keep the end r^6 of the positioning device in engagement with the stud B , I have employed a spring r^7 , and to disengage said positioning device from said stud when it is desired to turn the arms A^{10} A^{11} the arm r^5 of the positioning device will be turned in the

- direction of the arrow near its upper end in Fig. 15. This positioning device has a cam surface r^8 , (see Fig. 15,) which when the positioning device is turned to disengage the stud b acts to lift the end of a locking device r^9 , pivoted at r^{10} , removing said locking device from between two pins r^{12} , projecting from that end of the head h which supports the toe-wiper.
- 10 The spring H^9 is sometimes so set that it will lift the rod H^2 with very considerable force when the operator removes his foot from the treadle H^7 . This spring has to be checked in its upward movement, and to provide
- 15 for checking it the rod has secured to it the collar r , and to avoid shock and wear of both the clamp and the framework I have chambered the under side of the ear H^4 , letting the collar r enter it with a piston fit, thereby making a dash-pot of the ear H^4 , the collar cushioning on the air in the dash-pot.
- 20 Having described my invention, what I claim as new, and desire to secure by Letters Patent, is—
- 25 1. In a lasting-machine, a head and a last-pin-sustaining carriage adjustably connected therewith, a threaded sleeve pivoted on said carriage and a threaded last-holding pin mounted therein and in engagement with the threads of said sleeve, said pin having a hand-wheel, and means to tip the sleeve and pin to the requirements of the last.
- 30 2. In a lasting-machine, a jack-head, a carriage composed of a foot and body, the foot being slidably mounted on said head and the body being mounted on the foot loosely, means to slide the body transversely of said foot, a heel-pin, and adjustable means on said body and carrying said heel-pin.
- 35 3. In a lasting-machine, a head, a two-part

carriage mounted on said head, one part of the carriage being loosely mounted on the other part thereof, means to slide one part of the carriage on the other part thereof, a heel-pin, an adjustable carrier for said heel-pin, and a device to tip said heel-pin carrier. 45

4. In a lasting-machine, a tipping-plate, a crimping-jaw-carrying block slidably mounted in said plate and having a passage through it from top to bottom, a lever mounted loosely on said block and having an arm extended through the passage of the block, and a link connecting said arm and tipping-plate, whereby by turning the lever the block may be slid in said plate. 50

5. In a lasting-machine, a block, crimping-jaws mounted thereon, means to actuate said jaws, and a toe-lasting plate located below the crimping-jaws and having a series of notches of varying size adapted to operate with lasts of varying size and shape. 55

6. In a lasting-machine, a head carrying a heel-pin and toe-wiper, combined with means sustaining toe-crimping jaws, and means to lock the means sustaining the toe-crimping jaws with said head. 60

7. In a lasting-machine, the arm A^{11} having the pivoted locking device, the lasting-head H having projections r^{12} , and a positioning device for the arm adapted in its movements to control the position of the locking device. 65

In testimony whereof I have signed my name to this specification in the presence of two subscribing witnesses.

HENRY H. CUMMINGS.

Witnesses:

GEO. W. GREGORY,
MARGARET A. DUNN.