



US00D720656S

(12) **United States Design Patent**
Glasener

(10) **Patent No.:** **US D720,656 S**

(45) **Date of Patent:** **** Jan. 6, 2015**

(54) **TILT TRAILER**

(71) Applicant: **Mark Glasener**, Chippewa Falls, WI (US)

(72) Inventor: **Mark Glasener**, Chippewa Falls, WI (US)

(**) Term: **14 Years**

(21) Appl. No.: **29/446,876**

(22) Filed: **Feb. 27, 2013**

(51) **LOC (10) Cl.** **12-10**

(52) **U.S. Cl.**
USPC **D12/101**

(58) **Field of Classification Search**
USPC D12/100-106, 19, 129, 111-112;
D21/425, 435; D34/21-26, 12, 16-19;
280/204, 205, 63, 475, 482, 647;
296/168, 180, 180.2, 61, 10,
296/100.01-100.08

See application file for complete search history.

(56) **References Cited**

U.S. PATENT DOCUMENTS

4,494,797	A *	1/1985	Carberry	298/5
4,568,235	A *	2/1986	Bills, Jr.	414/477
5,411,284	A *	5/1995	Harbin	280/656
5,967,733	A *	10/1999	Cash	414/483
6,537,014	B1 *	3/2003	Ridgill	414/482

* cited by examiner

Primary Examiner — Katrina A Betton

(74) *Attorney, Agent, or Firm* — Anthony J. Bourget

(57) **CLAIM**

The ornamental design for a tilt trailer, as shown and described.

DESCRIPTION

FIG. 1 is a front perspective view of our new design of a tilt trailer;

FIG. 2 is a front perspective view of the tilt trailer of FIG. 1 with rack tilted;

FIG. 3 is a right side elevational view of the tilt trailer of FIG. 1, the left side view being a mirror image thereof;

FIG. 4 is a front end view of the tilt trailer of FIG. 2;

FIG. 5 is a rear end view of the tilt trailer of FIG. 2;

FIG. 6 is a top view of the tilt trailer of FIG. 2;

FIG. 7 is a bottom view thereof of the tilt trailer of FIG. 2;

FIG. 8 is a right side elevational view of the tilt trailer of FIG. 3 with rack tilted;

FIG. 9 is a front perspective view of our tilt trailer having an alternative inventive design;

FIG. 10 is a right side elevational view of the tilt trailer of FIG. 9 with rack lowered, the left side view being a mirror image thereof;

FIG. 11 is a right side elevational view of the tilt trailer of FIG. 9, the left side view being a mirror image thereof;

FIG. 12 is a top view of the tilt trailer of FIG. 9;

FIG. 13 is a front end view of the tilt trailer of FIG. 9;

FIG. 14 is a rear end view of the tilt trailer of FIG. 9; and,

FIG. 15 is a bottom view of the tilt trailer of FIG. 9.

The wheels, suspension, cylinders, king pin, and plate and accessories shown in broken lines form no part of the claimed design.

The broken lines of cylinders and the cylinder plate are removed from FIG. 1 for clarity.

FIG. 2 depicts rack in an alternate raised position.

1 Claim, 15 Drawing Sheets

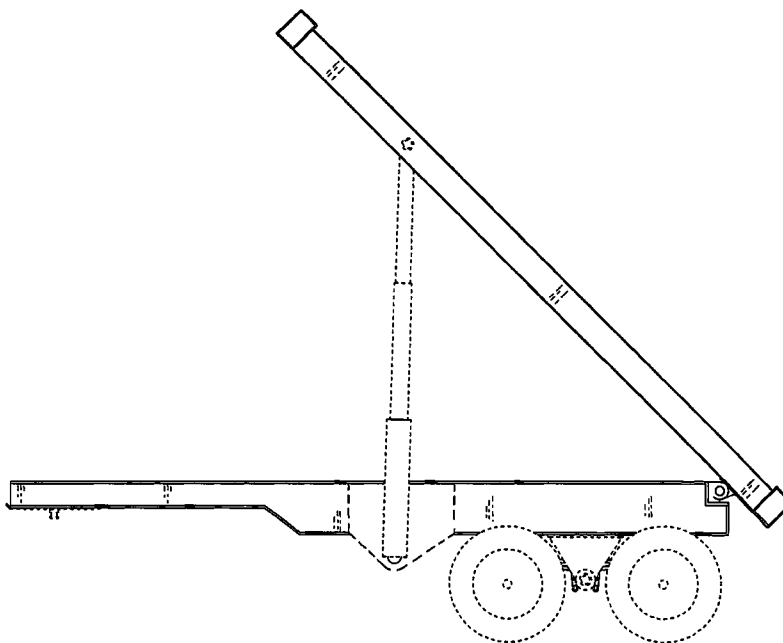

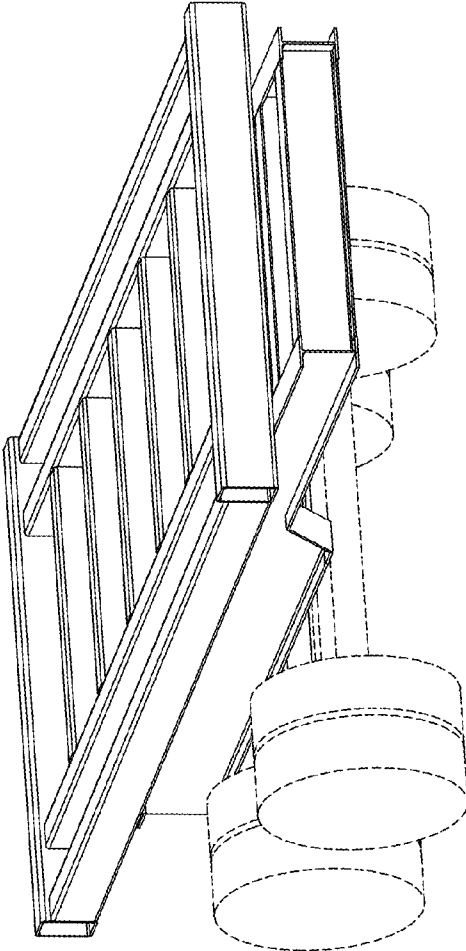

FIG. 1

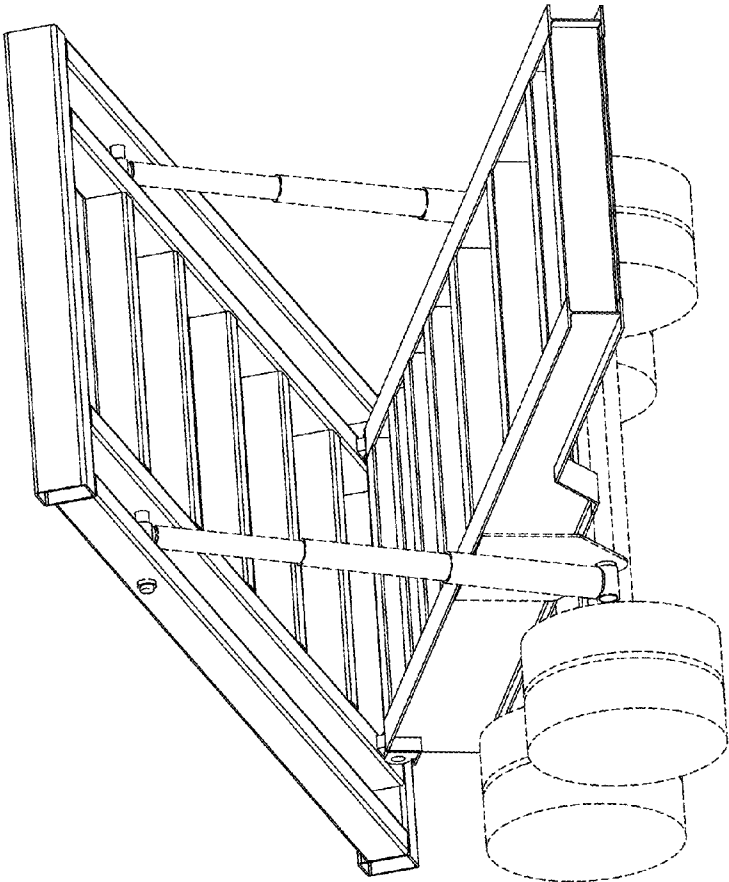

FIG. 2

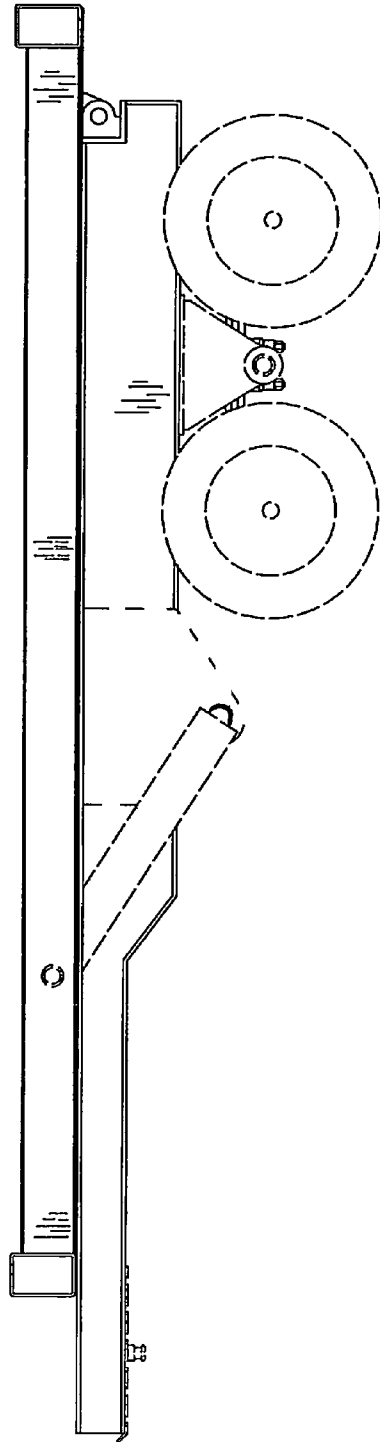

FIG. 3

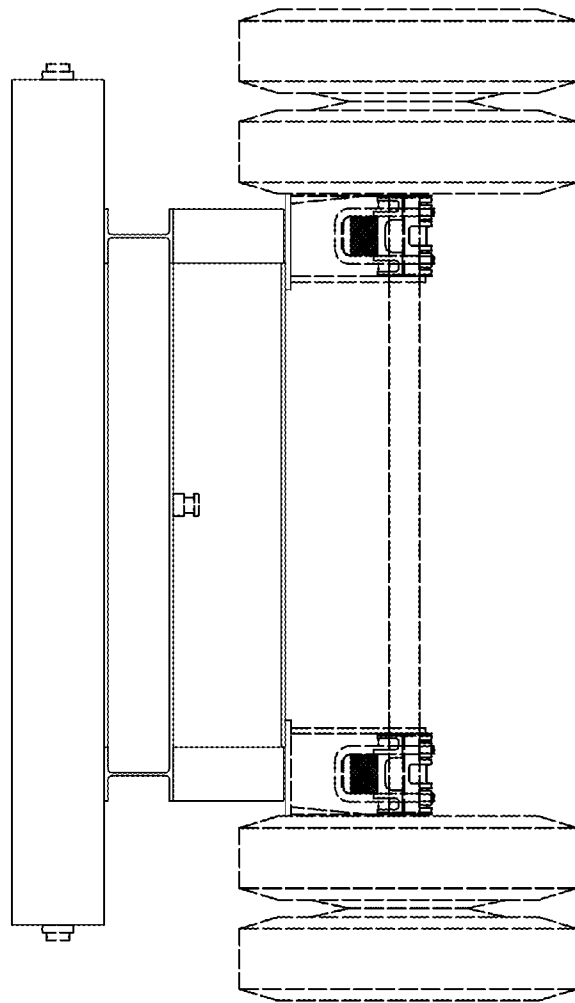

FIG. 4

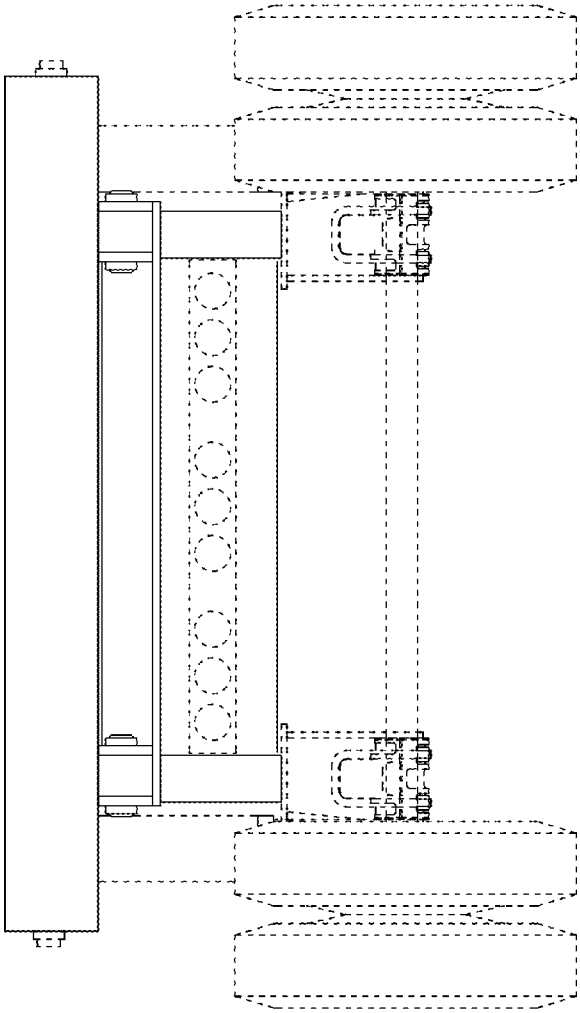

FIG. 5

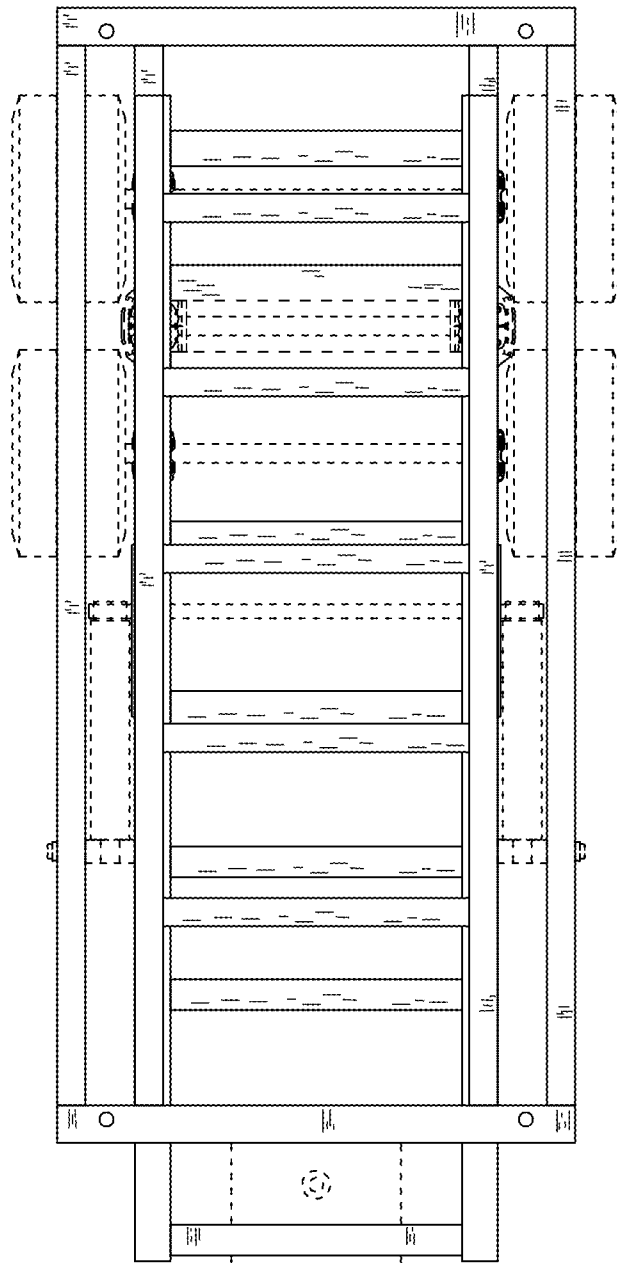

FIG. 6

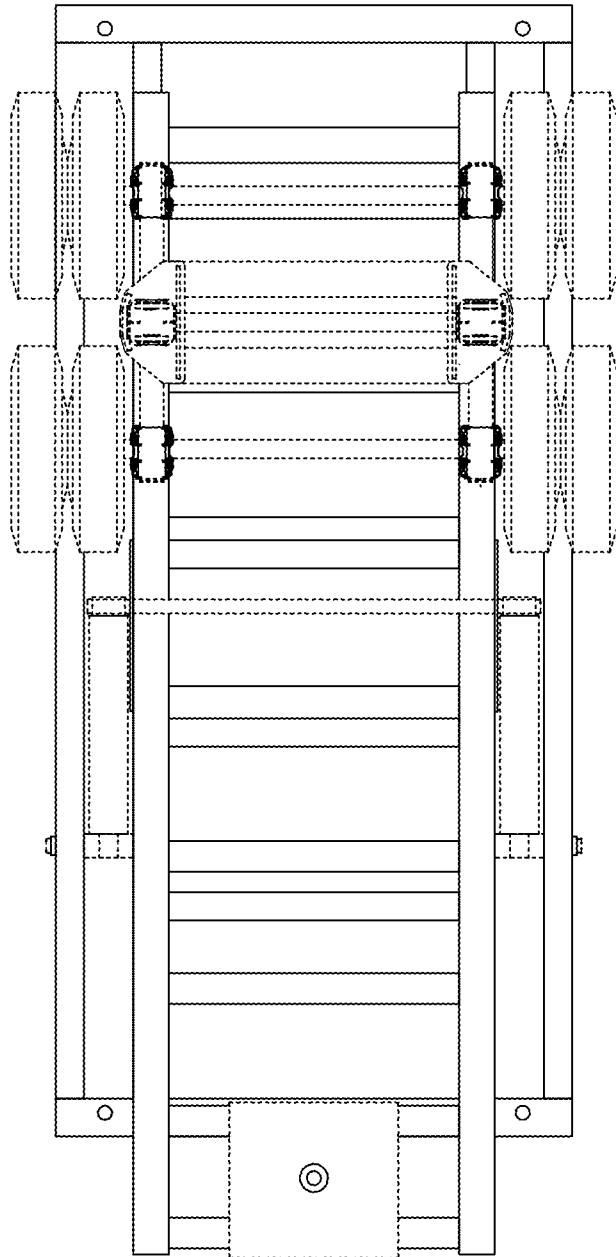

FIG. 7

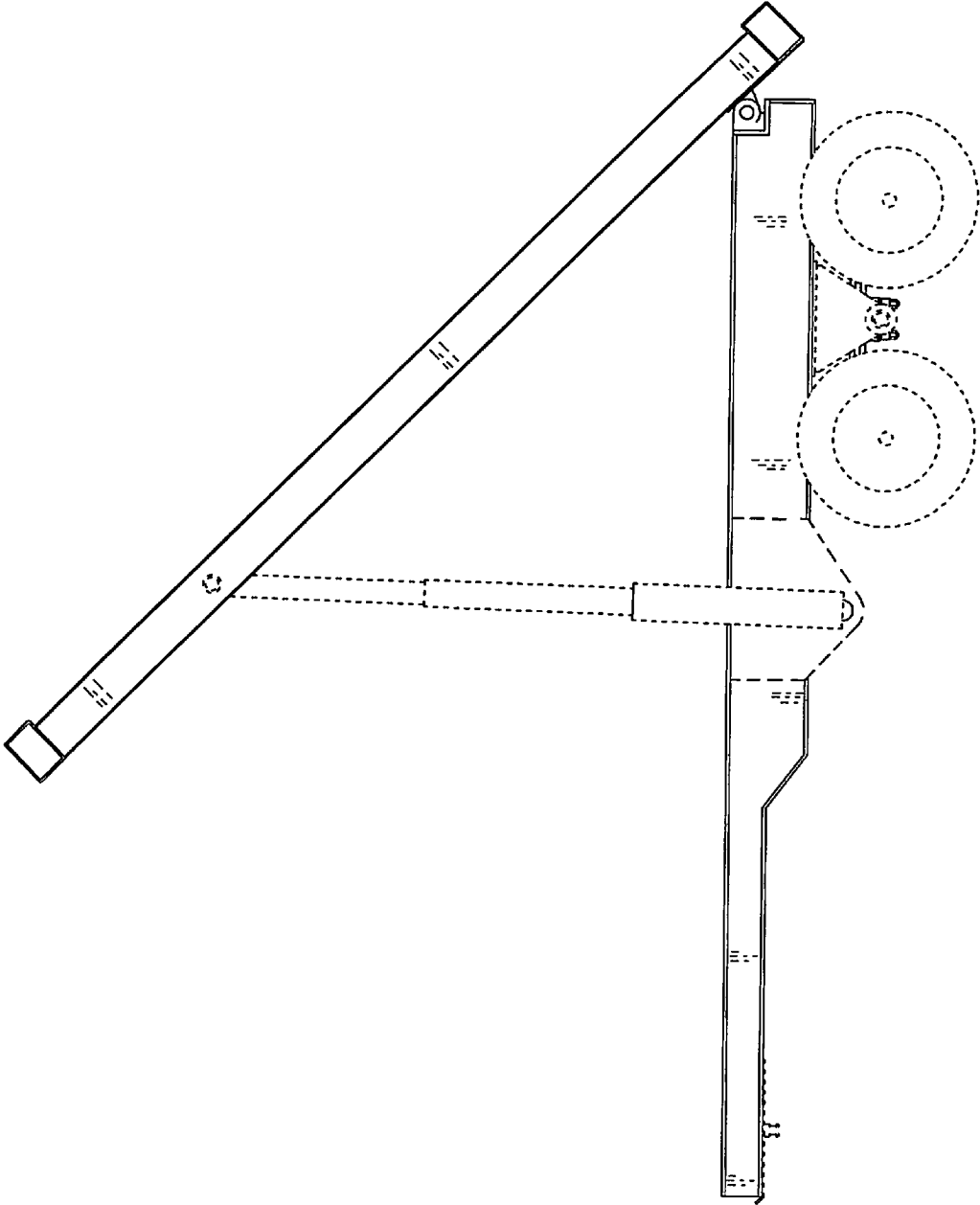

FIG. 8

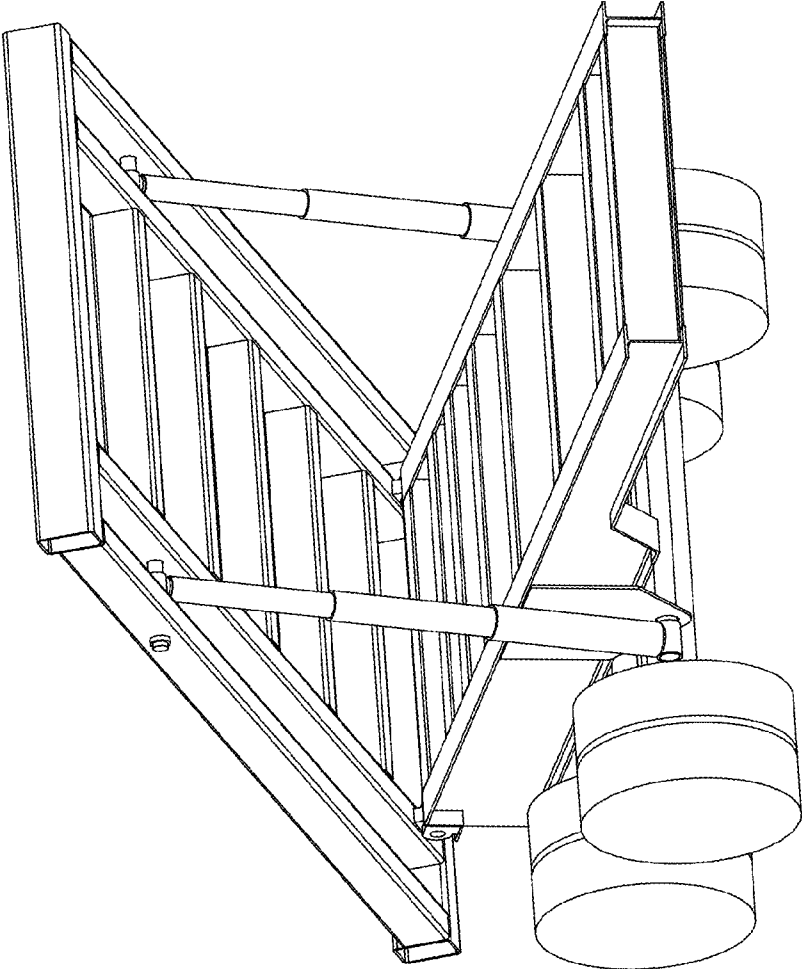

FIG. 9

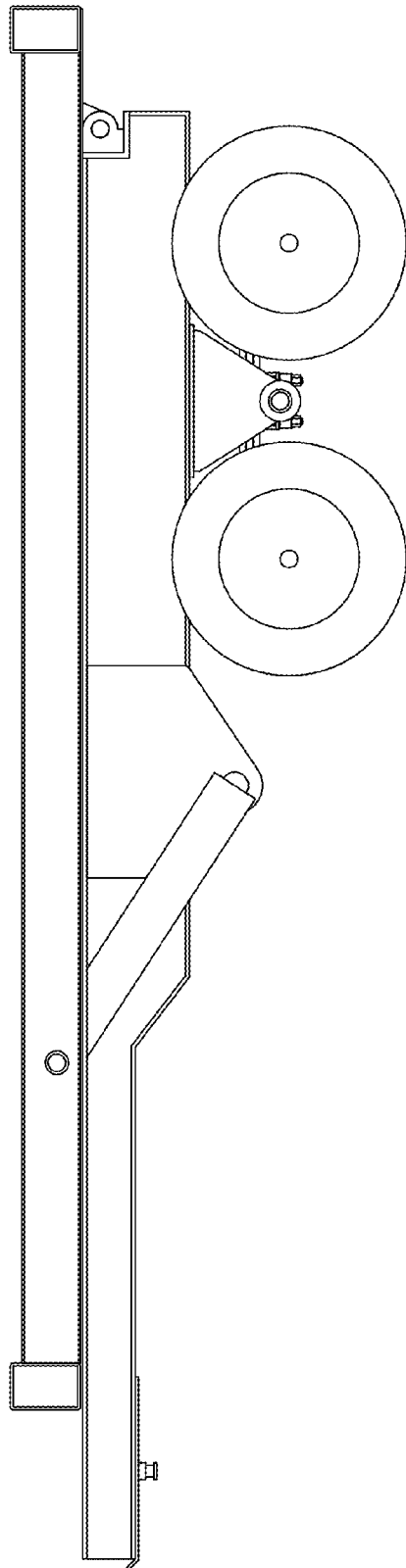

FIG. 10

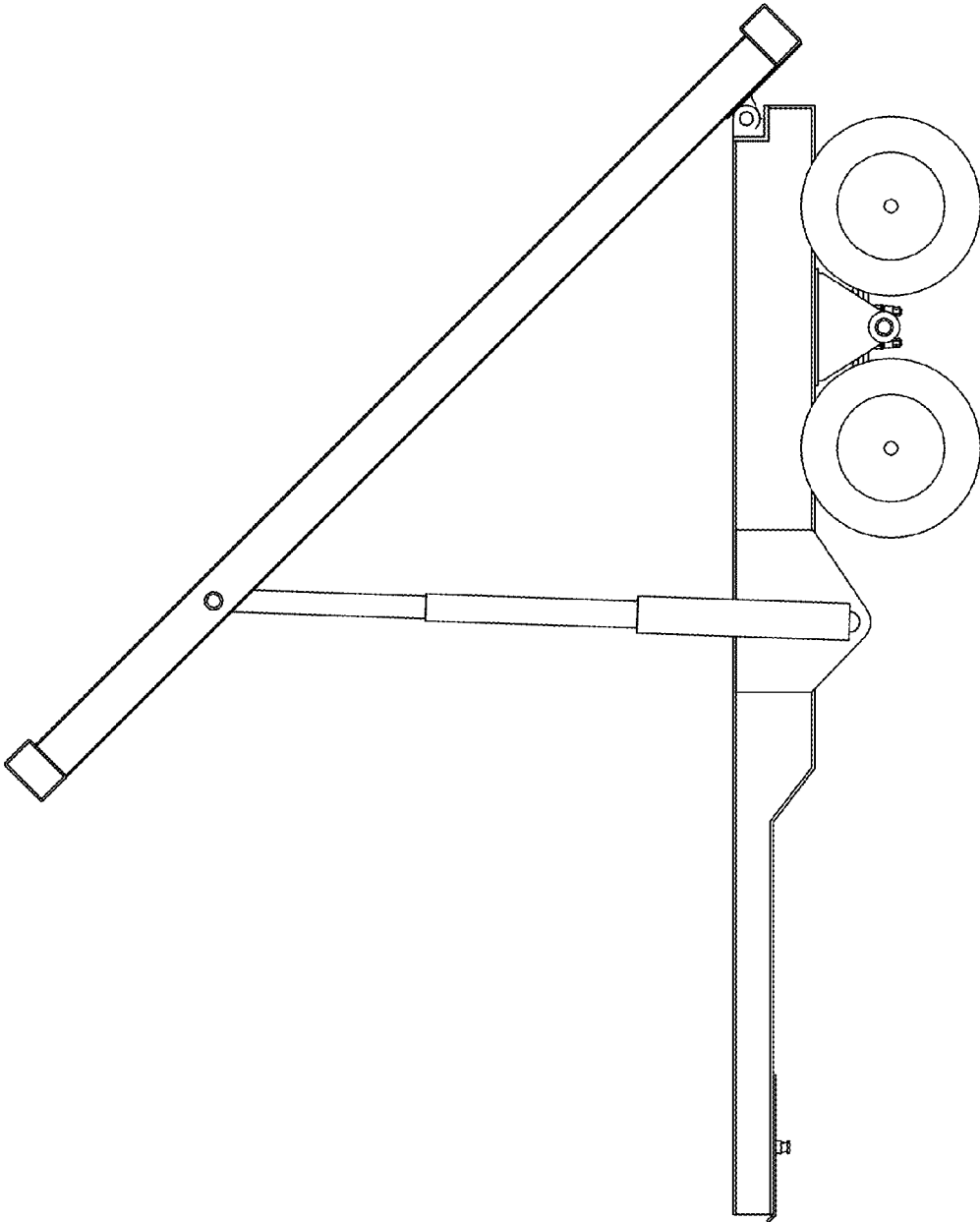

FIG. 11

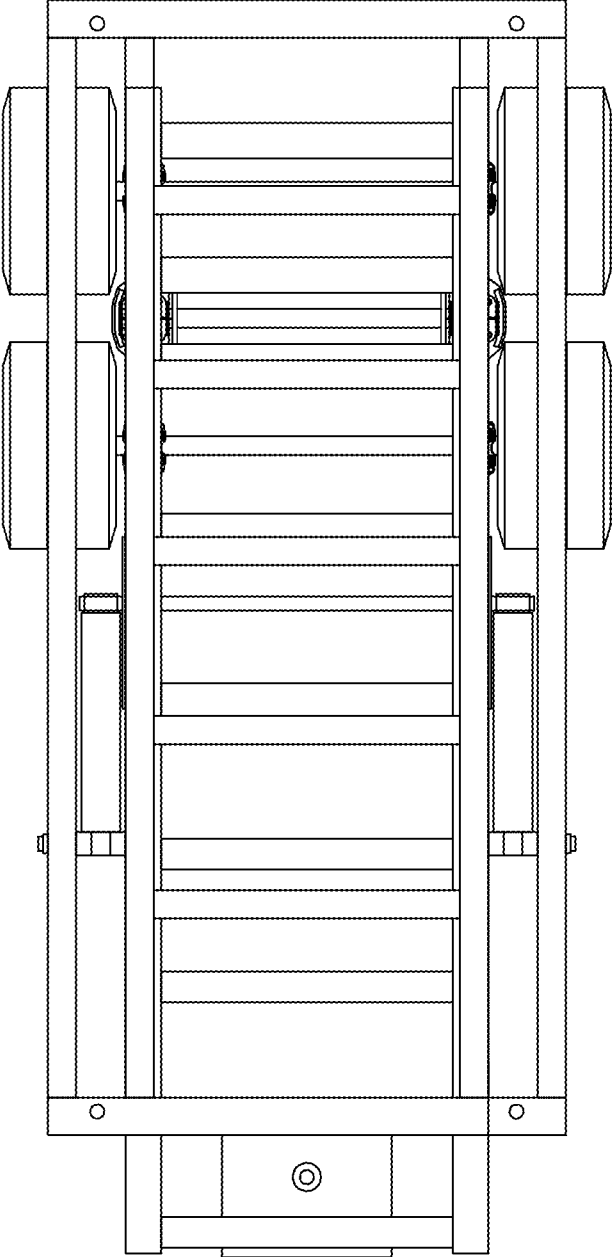

FIG. 12

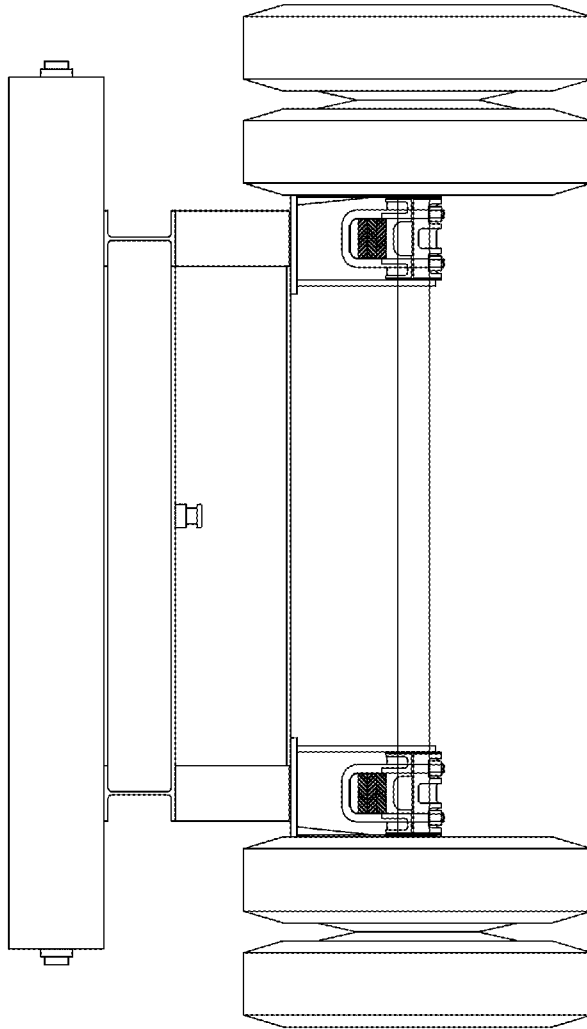

FIG. 13

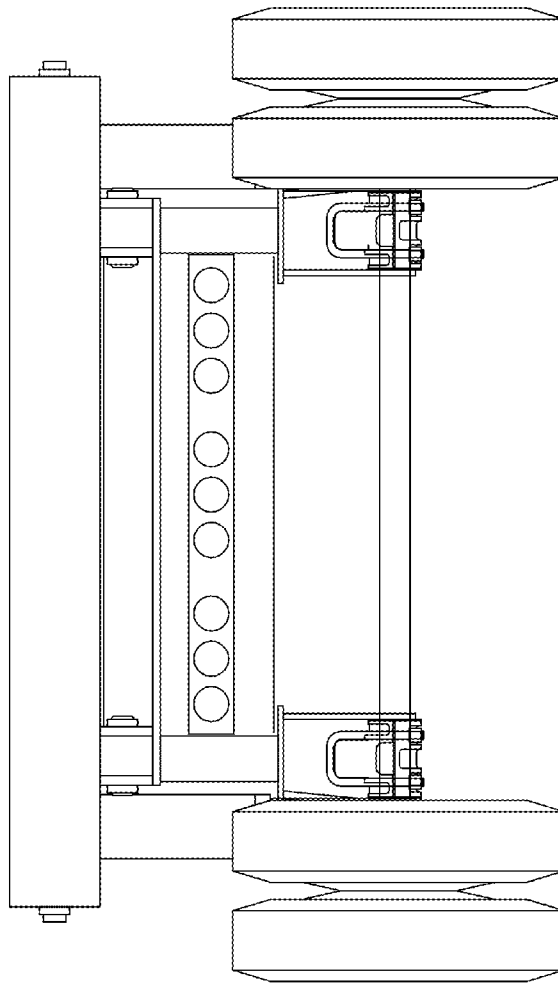

FIG. 14

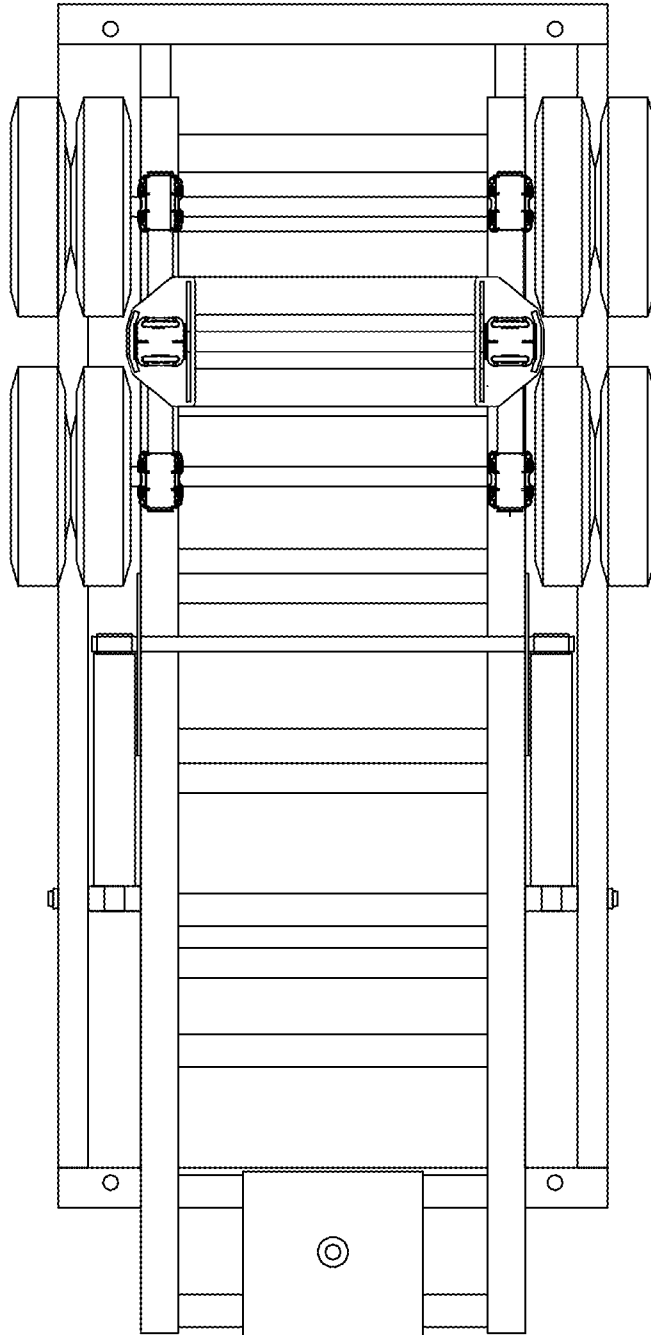

FIG. 15