



(51) International Patent Classification:

D06F 58/22 (2006.01) *B01D 35/02* (2006.01)
D06F 58/45 (2020.01)

(21) International Application Number:

PCT/TR2023/050369

(22) International Filing Date:

18 April 2023 (18.04.2023)

(25) Filing Language:

Turkish

(26) Publication Language:

English

(30) Priority Data:

2023/001003 27 January 2023 (27.01.2023) TR

(71) Applicant: **RENTA ELEKTRIKLI EV ALETLERI SANAYI VE DIS TICARET LIMITED SIRKETI** [TR/TR]; Organize Sanayi Bolgesi 7. Cadde No:24, Odunpazari/Eskisehir (TR).

(72) Inventors: **YILDIRAN, Vasif Can**; Organize Sanayi Bolgesi 7. Cadde No:24, Odunpazari/Eskisehir (TR). **BANI,**

Mustafa; Organize Sanayi Bolgesi 7. Cadde No:24, Odunpazari/Eskisehir (TR).

(74) Agent: **KAYA, Erdem**; Konak Mh. Kudret Sok. Elitpark Park Sit. Ofisler Apt. No:12/27, 16110 Nilufer/Bursa (TR).

(81) Designated States (unless otherwise indicated, for every kind of national protection available): AE, AG, AL, AM, AO, AT, AU, AZ, BA, BB, BG, BH, BN, BR, BW, BY, BZ, CA, CH, CL, CN, CO, CR, CU, CV, CZ, DE, DJ, DK, DM, DO, DZ, EC, EE, EG, ES, FI, GB, GD, GE, GH, GM, GT, HN, HR, HU, ID, IL, IN, IQ, IR, IS, IT, JM, JO, JP, KE, KG, KH, KN, KP, KR, KW, KZ, LA, LC, LK, LR, LS, LU, LY, MA, MD, MG, MK, MN, MU, MW, MX, MY, MZ, NA, NG, NI, NO, NZ, OM, PA, PE, PG, PH, PL, PT, QA, RO, RS, RU, RW, SA, SC, SD, SE, SG, SK, SL, ST, SV, SY, TH, TJ, TM, TN, TR, TT, TZ, UA, UG, US, UZ, VC, VN, WS, ZA, ZM, ZW.

(84) Designated States (unless otherwise indicated, for every kind of regional protection available): ARIPO (BW, CV, GH, GM, KE, LR, LS, MW, MZ, NA, RW, SC, SD, SL, ST, SZ, TZ, UG, ZM, ZW), Eurasian (AM, AZ, BY, KG, KZ,

(54) Title: A TUMBLE DRYER WITH WATER TANK

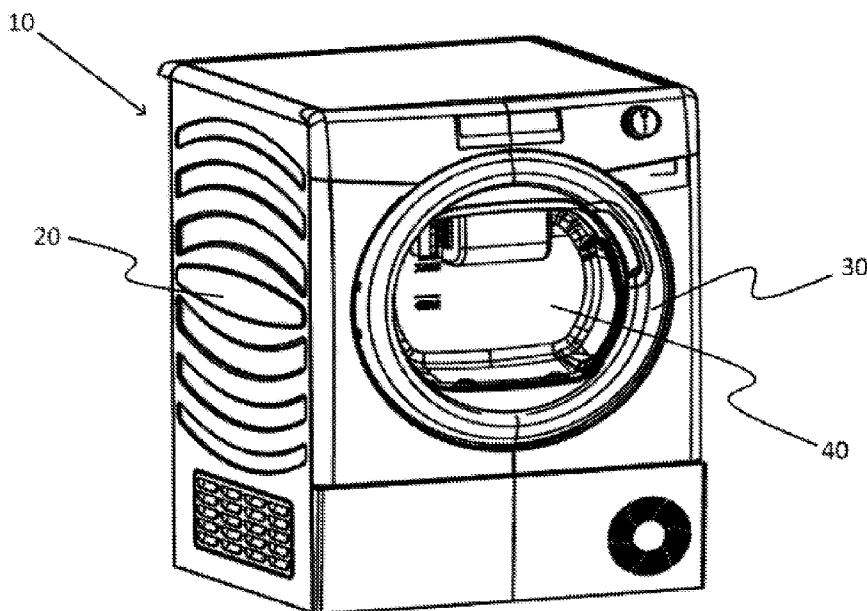

Figure 1

(57) Abstract: The invention relates to a tumble dryer (10) having a body (20), a drum (22) provided in the said body (20), and a cover (30) allowing access to the drum (22), and having a water tank (40) which allows the laundry to be dried by sending hot air into the drum (22) and wherein the water produced by condensation as a result of the drying process is stored, which is removably positioned on the cover (30). The novelty is that the water tank (40) comprises a microplastic gripper (50) provided in a water inlet port (41).



RU, TJ, TM), European (AL, AT, BE, BG, CH, CY, CZ, DE, DK, EE, ES, FI, FR, GB, GR, HR, HU, IE, IS, IT, LT, LU, LV, MC, ME, MK, MT, NL, NO, PL, PT, RO, RS, SE, SI, SK, SM, TR), OAPI (BF, BJ, CF, CG, CI, CM, GA, GN, GQ, GW, KM, ML, MR, NE, SN, TD, TG).

Published:

- *with international search report (Art. 21(3))*
- *in black and white; the international application as filed contained color or greyscale and is available for download from PATENTSCOPE*

A TUMBLE DRYER WITH WATER TANK

5 TECHNICAL FIELD

The invention relates to a tumble dryer in which microplastic particles can be separated from wastewater.

10 BACKGROUND

Today, measures are taken against the damage caused by micro-sized plastics released into nature. One of the important sources of microplastic emissions is laundry. When laundry is washed or dried, they release micro-sized fibers into the ecosystem. In a recent study, 15 6,000,000 microfibers are observed to be released from 6 kg of laundry (DeFalco et al., 2018). In washing and tumble dryers, microparticles are torn from the laundry due to heat and abrasion and thrown out with mains water. Microplastics that are released into the environment as waste enter the food chain or harm living things by inhalation.

20 The water withdrawn from the mains in the washing machines will take the detergent from the detergent box and will begin to fill the bowl where the laundry will be. After reaching a certain level, the machine stops taking water and the laundry starts washing. After the washing process is finished, the rinsing phase begins. The dirty water is discharged with the help of the pump motor and clean water is filled to a certain level in the boiler for the rinsing 25 process. With the effect of the drain pump and the high boiler speed, the laundry completes the rinsing process. Washing machines consume an average of 50 liters of water. Tumble dryers, on the other hand, have a drum cycle and a heated air process that provides regular dehumidification. Dehumidified air condenses in the condenser area and releases moisture into the condenser channel. Regularly accumulated water is discharged by the customer or 30 directly to the network. This amount of water is about 5 liters. As a result of this process, microplastics that break off from the laundry are sent to nature.

In the white goods sector, systems and designs that can be integrated outside the machine and inside the machine have been developed to prevent the release of microplastics from 35 washing machines.

Drying is also performed in tumble dryers by removing the moisture in the laundry. There are three different types of dryers on the market: heat pump, condenser, and chimney. The chimney-type dryers differ from other models by removing the air taken from the laundry with the help of a chimney. In condenser and heat pump models, the hot air leaving the drum leaves its moisture in the chamber inside the machine with the help of a condenser. The water collected in the tank is discharged at the end of the drying process. In the laundry drying process, microplastics are released as in washing machines, and with the return of wastewater to nature, the environment is polluted by microplastics.

As a result, all the above-mentioned problems have made it imperative to innovate in the relevant technical field.

BRIEF DESCRIPTION OF THE INVENTION

The present invention relates to a tumble dryer for eliminating the above-mentioned disadvantages and bringing new advantages to the relevant technical field.

The object of the invention is to provide a tumble dryer in which microplastic particles can be easily collected.

Another object of the invention is to provide a tumble dryer where microplastic particles can be collected at low costs.

The present invention relates to a tumble dryer having a body, a drum provided in said body, and a cover that allows access to the drum, sending hot air into the drum to dry the laundry, and a water tank that is removably positioned on the cover where the water is stored as a result of condensation as a result of the drying process in order to realize all the objects that will emerge from the abovementioned and the following detailed description. Accordingly, it includes a microplastic gripper provided at a water inlet port of the water tank. Thus, microplastic particles are collected during the transfer of the wastewater to the water tank for discharge.

The microplastic gripper is removably connected to the water tank in a possible embodiment of the invention. Thus, after the water tank is separated from the cover or before it is separated, the microplastic gripper can be discharged by removing it from its place and the microplastics are prevented from being mixed into the wastewater.

BRIEF DESCRIPTION OF THE FIGURES

Figure 1 shows a representative frontal isometric view of the tumble dryer of the invention.

5 Figure 2 shows a representative rear isometric view of the tumble dryer of the invention.

Figure 3 shows a frontal view of the water tank of the tumble dryer of the invention.

Figure 4 shows a rear view of the water tank of the tumble dryer of the invention.

10

DETAILED DESCRIPTION OF THE INVENTION

In this detailed description, the tumble dryer (10) of the invention is explained only by means of examples that will not have any limiting effect for a better understanding of the subject matter.

15

The tumble dryer (10) of the invention has a body (20). There is a drum (22) provided in the body (20). The drum (22) rotates with the drive it receives from a motor (not shown). It is possible to access the drum (22) by means of a cover (30) hinged on the body (20).

20

There is also a heater (23) to provide heating of the air inside the body (20) and a fan (21) to ensure that the heated air is directed into the drum (22). During the operation of the tumble dryer (10), the hot air dehumidifies the laundry. It is then condensed and collected in a tank (24). When the amount of water in the tank (24) exceeds a predetermined level, the water is sent to a water tank (40) through a pump (not shown in the figure).

25

In the tumble dryer (10) of the invention, the water tank (40) is located on the cover (30). On the other hand, the water tank (40) is removably connected to the face of the cover (30) facing the drum (22). Therefore, when water accumulates in the water tank (40), the user can easily see through the cover (30) and can empty the water tank (40) by removing it. The water tank (40) is made of a transparent material in a possible embodiment of the invention. There is also at least one handle (42) provided to allow easy holding of the water tank (40).

30

There is a water inlet port (41) on the water tank (40) to allow water to enter. The water sent from the tank (24) through the pump is poured into the water inlet port (41). There is a microplastic gripper (50) positioned in the water inlet port (41). Therefore, the water poured into the water inlet port (41) first enters the microplastic gripper (50). Said microplastic

35

gripper (50) allows the microplastic particles in the water to be retained. The microplastic gripper (50) is made of plastic material in a possible embodiment of the invention. The filtering element (51) used by adhering to the gaps on the microplastic gripper (50) is a transparent color. The fabric of the filtering element (51) of this microplastic gripper (50) can be made of different materials. The permeability of the fabric allows the flow of water while filtering microplastics. This is all about the number of pores and pore sizes of the fabric.

Due to the fact that the water tank (40) is positioned on the cover (30), the user can see the amount of waste in the microplastic gripper (50) when it is separated from the cover (30) to empty the water tank or when the water tank (40) is on the cover (30). Therefore, it can be intervened when necessary to drain the microplastic gripper (50), which is a kind of filter.

The microplastic gripper (50) is removably connected to the water tank (40) in a possible embodiment of the invention. Therefore, when the user separates the water tank (40) from the cover (30) to empty it, he/she can easily empty the microplastic gripper (50) by removing it from the water tank (40). In the alternative structure, it is possible to clean the microplastic gripper (50) without leaving the water tank (40).

There are 2 different cycles in the tumble dryer (10) of the invention, one open and the other closed. In the closed loop; the air inside the body (20) is first heated by passing through the heater (23) with the help of the fan (21) and then sent to the drum (22) where the laundry is located. The fan (21) receives its force from the motor that also moves the drum (22). The heated air takes up some of the moisture on the laundry as it passes through the drum (22). Hot and humid air is passed through a filter to hold the pieces of fiber that break off from the laundry and the air is directed into the condenser through the diverter channel. In the second cycle, the ambient air taken from the outside of the body (20) is directed to the condenser fins. Hot and humid air from the closed loop and ambient air taken from outside are cross-flowed through the condenser. Heat transfer is performed through fins integrated with condenser channels. The temperature of the closed loop air drops and some of the moisture condenses in the condenser channels to become liquid. The condensing water accumulates up to a predetermined amount in the tank (24) in the body (20). The pump starts when the fluid level exceeds the predetermined level. With the help of a pump, water is transported to the water tank (40) provided on the cover (30). The water passing through the microplastic gripper placed in the water inlet port (41) of the water tank (40) begins to fill the water tank (40). Thanks to the visibility of the water tank (40) and the microplastic gripper (50) on the cover (30), the user can empty the water tank (40) and thus the microplastic gripper (50) by separating from the cover (30) when he wants to empty any of them.

The microplastics can be easily collected in the tumble dryer (10) of the invention and the need can be easily detected by the user without the need for an additional sensor. On the other hand, since the microplastic gripper (50) is at the water inlet port (41) of the water tank (40) and in the area where the water is poured by gravity, no additional power is required to hold the particles.

The protection scope of the invention is specified in the appended claims and cannot be strictly limited to those explained in this detailed description for illustrative purposes. It is evident that a person skilled in the art may exhibit similar embodiments in light of the foregoing without departing from the main theme of the invention.

15

REFERENCE NUMBERS GIVEN IN THE FIGURES

- 10 Tumble dryer
- 20 Body
- 5
 - 21 Fan
 - 22 Drum
 - 23 Heater
 - 24 Tank
- 30 Cover
- 10 40 Water tank
 - 41 Water inlet port
 - 42 Handle
- 50 Microplastic gripper
- 51 Filtering element
- 15
- 20
- 25

CLAIMS

- 5
1. A tumble dryer (10) having a body (20), a drum (22) provided in the said body (20), and a cover (30) allowing access to the drum (22), and having a water tank (40) which allows the laundry to be dried by sending hot air into the drum (22) and wherein the water produced by condensation as a result of the drying process is stored, which is removably positioned on the cover (30), **characterized in that** the water tank (40) comprises a microplastic gripper (50) provided in a water inlet port (41).
 - 10 2. A tumble dryer (10) according to Claim 1, **characterized in that** the microplastic gripper (50) is removably connected to the water tank (40).
- 15

1/2

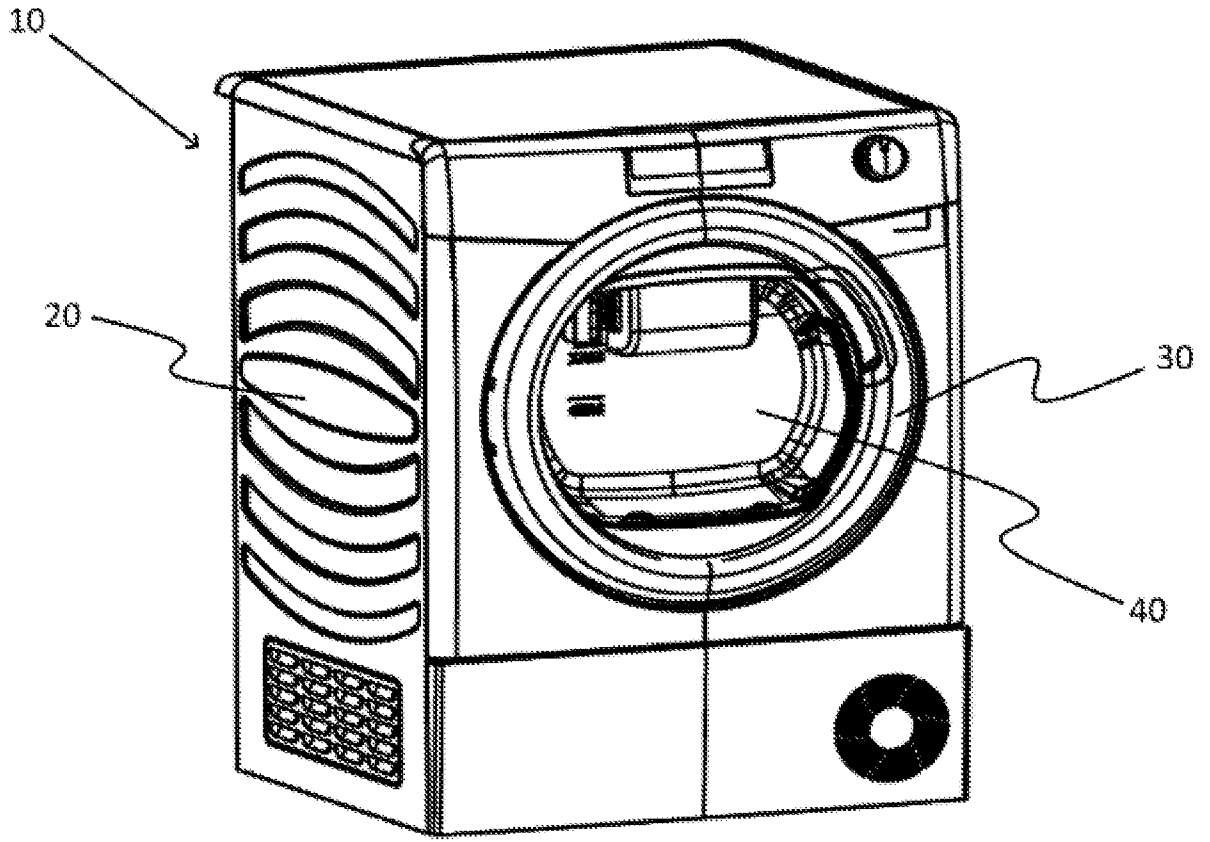

Figure 1

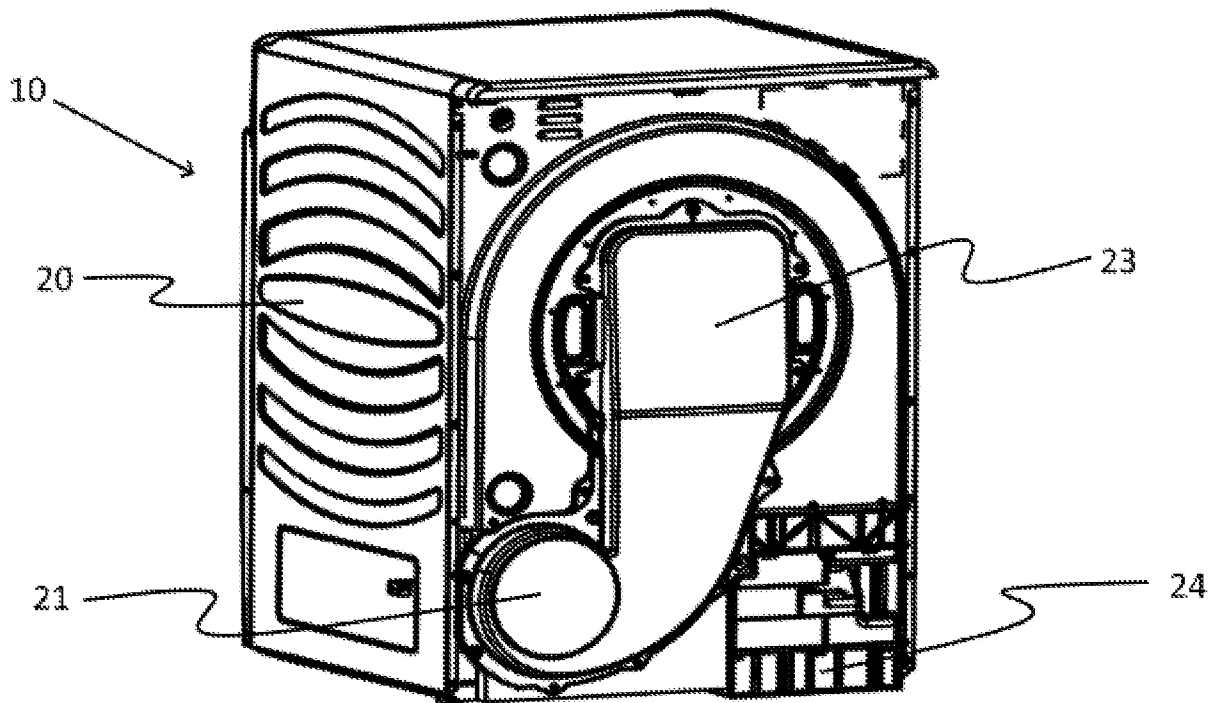

Figure 2

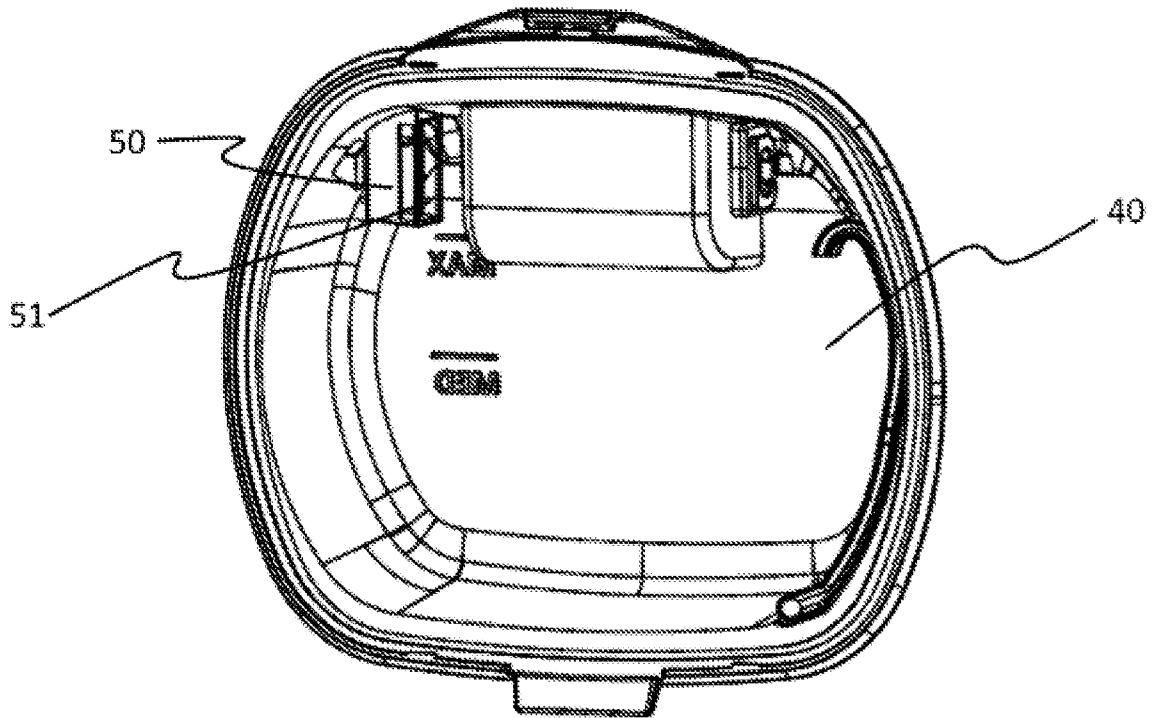

Figure 3

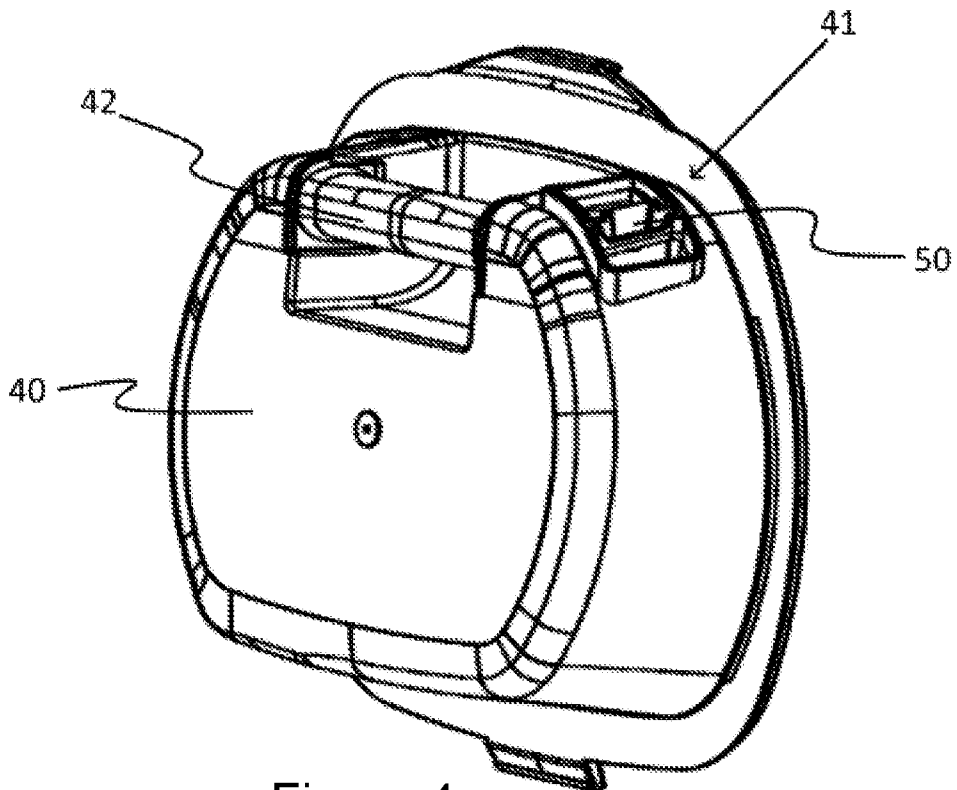

Figure 4

INTERNATIONAL SEARCH REPORT

International application No.

PCT/TR2023/050369

A. CLASSIFICATION OF SUBJECT MATTER		
D06F 58/22 (2006.01)i; D06F 58/45 (2020.01)i; B01D 35/02 (2006.01)i		
According to International Patent Classification (IPC) or to both national classification and IPC		
B. FIELDS SEARCHED		
Minimum documentation searched (classification system followed by classification symbols) D06F; B01D		
Documentation searched other than minimum documentation to the extent that such documents are included in the fields searched TURKPATENT Database		
Electronic data base consulted during the international search (name of data base and, where practicable, search terms used) EPODOC		
C. DOCUMENTS CONSIDERED TO BE RELEVANT		
Category*	Citation of document, with indication, where appropriate, of the relevant passages	Relevant to claim No.
A	KR 20210052079 A (SAMSUNG ELECTRONICS CO LTD [KR]) 10 May 2021 (2021-05-10) Whole document	1-2
A	EP 2386679 A1 (SAMSUNG ELECTRONICS CO LTD [KR]) 16 November 2011 (2011-11-16) Whole document	1-2
<input type="checkbox"/> Further documents are listed in the continuation of Box C. <input checked="" type="checkbox"/> See patent family annex.		
<p>* Special categories of cited documents:</p> <p>“A” document defining the general state of the art which is not considered to be of particular relevance</p> <p>“D” document cited by the applicant in the international application</p> <p>“E” earlier application or patent but published on or after the international filing date</p> <p>“L” document which may throw doubts on priority claim(s) or which is cited to establish the publication date of another citation or other special reason (as specified)</p> <p>“O” document referring to an oral disclosure, use, exhibition or other means</p> <p>“P” document published prior to the international filing date but later than the priority date claimed</p> <p>“T” later document published after the international filing date or priority date and not in conflict with the application but cited to understand the principle or theory underlying the invention</p> <p>“X” document of particular relevance; the claimed invention cannot be considered novel or cannot be considered to involve an inventive step when the document is taken alone</p> <p>“Y” document of particular relevance; the claimed invention cannot be considered to involve an inventive step when the document is combined with one or more other such documents, such combination being obvious to a person skilled in the art</p> <p>“&” document member of the same patent family</p>		
Date of the actual completion of the international search 01 September 2023		Date of mailing of the international search report 01 September 2023
Name and mailing address of the ISA/TR Turkish Patent and Trademark Office (Turkpatent) Hipodrom Caddesi No. 13 06560 Yenimahalle Ankara Türkiye Telephone No. +903123031000 Facsimile No. +903123031220		Authorized officer Yusuf Emre OYACI Telephone No. +903123031662

INTERNATIONAL SEARCH REPORT
Information on patent family members

International application No.

PCT/TR2023/050369

Patent document cited in search report			Publication date (day/month/year)	Patent family member(s)			Publication date (day/month/year)
KR	20210052079	A	10 May 2021	WO	2021085968	A1	06 May 2021
EP	2386679	A1	16 November 2011	US	8615895	B2	31 December 2013