

No. 671,982.

Patented Apr. 16, 1901.

D. J. STROHMEYER.  
SOAP PRESS.

(Application filed June 4, 1900.)

(No Model.)

2 Sheets—Sheet 1.

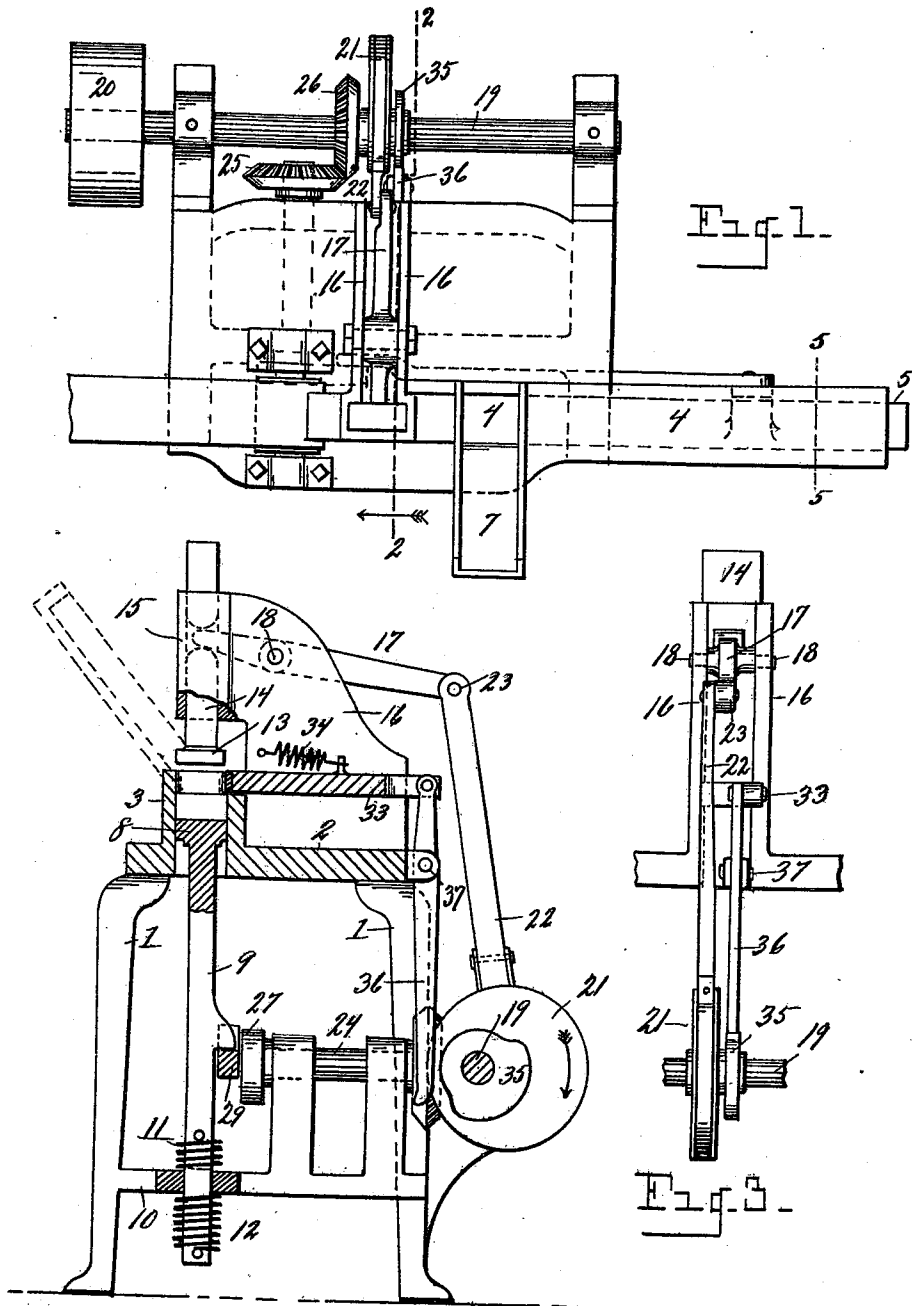

WITNESSES.

*W. Parry*  
*W. J. Foster*

Fig. 2

INVENTOR.

*David J. Strohmeyer*  
*By R. W. Wheeler & Co.*

Attorneys.

No. 671,982.

Patented Apr. 16, 1901.

D. J. STROHMEYER.  
SOAP PRESS.

(Application filed June 4, 1900.)

(No Model.)

2 Sheets—Sheet 2.

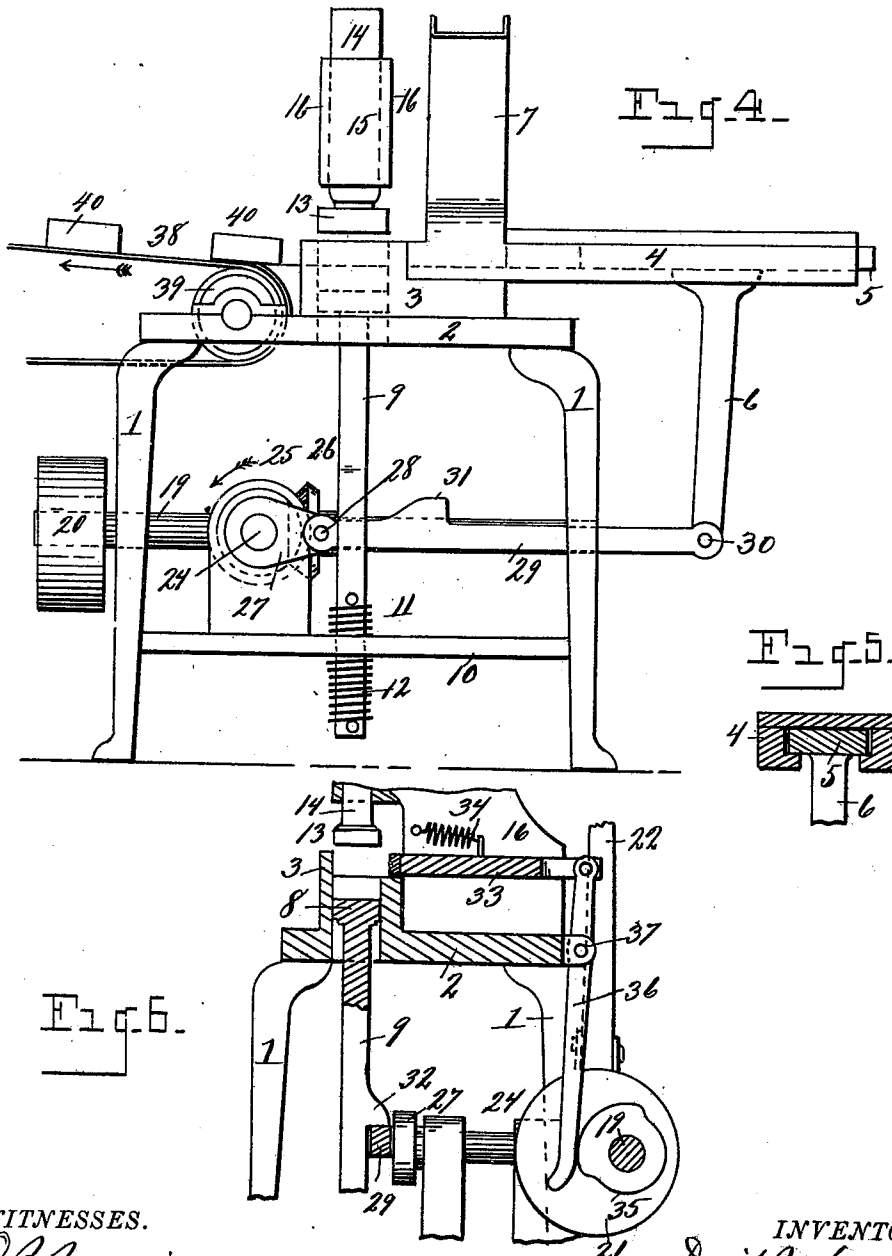

WITNESSES.

*O. P. Bruegger*  
*W. E. S. J. J. J.*

INVENTOR.

*David J. Strohmeyer*

*By R. B. Wheeler & Co.*

Attorneys.

# UNITED STATES PATENT OFFICE.

DAVID J. STROHMEYER, OF DETROIT, MICHIGAN, ASSIGNOR OF ONE-HALF TO THE SCHULTE SOAP COMPANY, OF SAME PLACE.

## SOAP-PRESS.

SPECIFICATION forming part of Letters Patent No. 671,982, dated April 16, 1901.

Application filed June 4, 1900. Serial No. 18,983. (No model.)

To all whom it may concern:

Be it known that I, DAVID J. STROHMEYER, a citizen of the United States, residing at Detroit, in the county of Wayne, State of Michigan, have invented certain new and useful Improvements in Soap-Presses; and I do declare the following to be a full, clear, and exact description of the invention, such as will enable others skilled in the art to which it appertains to make and use the same, reference being had to the accompanying drawings, and to the figures of reference marked thereon, which form a part of this specification.

This invention relates to a power soap-press; and it consists in the construction and arrangement of parts hereinafter fully set forth, and pointed out particularly in the claims.

The object of the invention is to provide a machine of the character described of comparatively simple and inexpensive construction in which the arrangement is such as to provide for rapidly pressing or molding the soap, feeding the soap in successive cakes to the die-box or mold to receive an impression, conveying the cakes from the machine when released from the dies, and freeing the dies from the cakes of soap after each impression.

The above object is attained by the mechanism illustrated in the accompanying drawings, in which—

Figure 1 is a plan view of my improved machine. Fig. 2 is a transverse section, as on line 2 2 of Fig. 1. Fig. 3 is a detail in rear elevation of the mechanism for actuating the upper die and the horizontally-reciprocal stripping-bar. Fig. 4 is a front elevation of the machine. Fig. 5 is a transverse section through the feeding-slide, as on line 5 5 of Fig. 1. Fig. 6 is a transverse section similar to Fig. 2, showing a different position of the operative parts, portions being broken away.

Referring to the characters of reference, 1 designates a frame of any suitable construction, upon which is mounted a bed-plate 2, carrying the mold or die-box 3, having communicating therewith a way 4, in which a slide 5 is adapted to reciprocate horizontally, said way being open longitudinally of its under face to accommodate the depending arm 6, attached to the slide and through the me-

dium of which it is operated. Communicating with the way 4, between the inner end of said slide 5 and the die-box, is a chute 7, which serves to direct the cakes of soap into the way 4 in advance of said slide. Located in the die-box is the lower die 8, attached to the upper end of the vertically-reciprocatory stem or plunger 9, whose lower end passes through a cross-bar 10 of the frame and is environed by the coiled springs 11 and 12, respectively, which are attached at one end to said plunger and bear against the opposite faces of the cross-piece 10, through which said plunger passes.

The upper die 13 is mounted upon a vertically-reciprocatory stem 14, located in a suitable guideway 15, supported by the uprights 16, mounted upon the bed of the frame. The upper die is actuated through the medium of a lever 17, fulcrumed at 18 between the uprights 16 and actuated in a manner hereinafter set forth.

The main shaft 19 is suitably journaled in the frame and is driven through the medium of a pulley 20. Mounted upon said shaft is an eccentric 21, which is strapped to a connecting-rod 22, whose upper end is pivoted at 23 to the outer end of the lever 17, the inner end of said lever engaging in a flaring aperture in the stem 14 of the die 13, as clearly shown by dotted lines in Fig. 2, whereby by a rotation of the shaft 19 the lever 17 is actuated to cause a vertical reciprocation of said upper die. A counter-shaft 24 is also journaled in the frame and is driven through a beveled gear 25 on one end thereof, which meshes with a like gear 26 on the shaft 19. Upon the opposite end of the shaft 24 is a crank 27, which is pivoted at 28 to one end of a connecting-rod 29, the opposite end of said rod being pivoted at 30 to the depending arm 6 of the slide 5. It will now be understood that a rotation of the shaft 19 will also turn the shaft 24 and cause a reciprocation of the rod 29, thereby imparting a horizontal reciprocation to the slide 5, which operation causes said slide to feed the cakes of soap supplied thereto from the chute 7 successively into the die-box or mold 3, in which they are engaged between the opposed faces of the converging dies, the upper die being

depressed through the operation of the eccentric 21 and the lower die being momentarily held in place while the upper die descends, through the engagement of the connecting-rod 29 with the shoulder 32 on the plunger of said die. As the upper die recedes after an impression the lower die is raised or caused to follow it through the engagement of the inclined plane 31 on said connecting-rod with said shoulder 32, whereby the face of the lower die is elevated sufficiently to cause it to stand flush with the top of the die-box, enabling the cake last pressed to be discharged from the die-box by the succeeding cake, which is forced into position by the synchronous operation of the slide 5. When the movement of the connecting-rod 29 carries the incline 31 thereon past the shoulder 32 on the stem of the lower die, said die will be retracted vertically through the operation of the spring 12 on its lower end, so as to withdraw said die from the path of the succeeding cake forced into the die-box and permit said cake to be deposited upon the upper face of said lower die. The upper spring 11, upon the plunger of the lower die, serves to cushion said plunger in its descent.

To obviate the sticking of the bars of soap to the faces of the dies when said dies separate after an impression, a horizontally-reciprocal stripping-bar 33 is employed, whose free end is adapted to be projected inwardly beyond the inner wall of the die-box to engage and confine the cake of soap with some pressure between its end and the opposite wall of said box, whereby the cake of soap is prevented from adhering to the dies as they separate and is held in a position to be discharged from the die-box by the succeeding cake as it moves forward through the operation of the slide. The coiled spring 34, which engages the stripping-bar, exerts its tension to hold said bar against the cake of soap at the moment of the separation of the dies, said bar being withdrawn from the path of the upper die in its descent by means of a cam 35 upon the main shaft 19, whose high point engages the free end of the lever 36, fulcrumed at 37 to the frame and pivoted at its upper end to the bar 33, the arrangement being such that upon the descent of the upper die the high point of said cam engages said lever and operates it to retract the stripping-bar, as shown in Fig. 6.

To provide for conveying the cakes of soap from the machine after being pressed, an

endless belt 38 is employed, which is driven from any suitable source of power and passes over a pulley 39, adjacent to the die-box 3, so that the cakes of soap 40, after being pressed, may be projected from said box onto said belt and by it conveyed to any desired point, as clearly shown in Fig. 4.

Having thus fully set forth my invention, what I claim is—

1. In a soap-press, the combination of the mold or die box, the plungers carrying the dies adapted to converge and recede within said box, the horizontally-movable slide for feeding the bars of soap consecutively to the dies, an arm rigidly attached to and depending from said slide, a shaft carrying a crank, a horizontally-reciprocatory connecting-rod pivoted to said crank and to the lower end of the arm depending from said slide, the plunger of the lower die having a projecting shoulder standing in the path of said connecting-rod and an inclined plane upon said rod adapted to engage said shoulder.

2. In a soap-press, the combination with the means for feeding the bars of soap through the machine, of a die-box in the path of said bars, an upper and a lower plunger adapted to reciprocate within said die-box, means for moving said plungers, the lower plunger passing through a cross-piece in the frame, said lower plunger having a stop thereon upon each side of said cross-piece, a spring upon said plunger confined between the upper side of said cross-piece and one of said stops and a second spring upon said plunger confined between the under side of said cross-piece and the other of said stops.

3. In a soap-press, the combination of the die-box, means for feeding the soap to said die-box, an upper and a lower die adapted to reciprocate within said box, a stripping-bar adapted to move at right angles to the path of said dies and adapted to extend into the die-box, a spring for normally holding said bar projected, a cam upon the shaft of the machine, a lever fulcrumed between its ends and having its upper end pivoted to said stripping-bar and its lower end depending in the path of said cam.

In testimony whereof I sign this specification in the presence of two witnesses.

DAVID J. STROHMEYER.

Witnesses:

JOHN H. SCHULTE,  
E. S. WHEELER.