

(19) World Intellectual Property Organization
International Bureau



(43) International Publication Date
21 September 2006 (21.09.2006)

PCT

(10) International Publication Number
WO 2006/099362 A1

- (51) International Patent Classification:
E21B 21/08 (2006.01)
- (21) International Application Number:
PCT/US2006/009013
- (22) International Filing Date: 13 March 2006 (13.03.2006)
- (25) Filing Language: English
- (26) Publication Language: English
- (30) Priority Data:
60/661,113 11 March 2005 (11.03.2005) US
- (71) Applicant (for all designated States except US): **BAKER HUGHES INCORPORATED** [US/US]; 3900 Essex Lane, Suite 1200, Houston, Texas 77027 (US).
- (72) Inventors; and
- (75) Inventors/Applicants (for US only): **KRUEGER, Sven**; Eichenring 127, 29308 Winsen/Aller (DE). **KRUEGER, Volker**; Sassengarten 8, 29223 Celle (DE).
- (74) Agents: **RIDDLE, J., Albert** et al.; BAKER HUGHES INCORPORATED, 3900 ESSEX LANE, Suite 1200, Houston, Texas 77027 (US).

- (81) Designated States (unless otherwise indicated, for every kind of national protection available): AE, AG, AL, AM, AT, AU, AZ, BA, BB, BG, BR, BW, BY, BZ, CA, CH, CN, CO, CR, CU, CZ, DE, DK, DM, DZ, EC, EE, EG, ES, FI, GB, GD, GE, GH, GM, HR, HU, ID, IL, IN, IS, JP, KE, KG, KM, KN, KP, KR, KZ, LC, LK, LR, LS, LT, LU, LV, LY, MA, MD, MG, MK, MN, MW, MX, MZ, NA, NG, NI, NO, NZ, OM, PG, PH, PL, PT, RO, RU, SC, SD, SE, SG, SK, SL, SM, SY, TJ, TM, TN, TR, TT, TZ, UA, UG, US, UZ, VC, VN, YU, ZA, ZM, ZW.
- (84) Designated States (unless otherwise indicated, for every kind of regional protection available): ARIPO (BW, GH, GM, KE, LS, MW, MZ, NA, SD, SL, SZ, TZ, UG, ZM, ZW), Eurasian (AM, AZ, BY, KG, KZ, MD, RU, TJ, TM), European (AT, BE, BG, CH, CY, CZ, DE, DK, EE, ES, FI, FR, GB, GR, HU, IE, IS, IT, LT, LU, LV, MC, NL, PL, PT, RO, SE, SI, SK, TR), OAPI (BF, BJ, CF, CG, CI, CM, GA, GN, GQ, GW, ML, MR, NE, SN, TD, TG).

Published:
— with international search report

[Continued on next page]

(54) Title: CONTROL SYSTEMS AND METHODS FOR REAL TIME PRESSURE MANAGEMENT (ECDCONTROL)

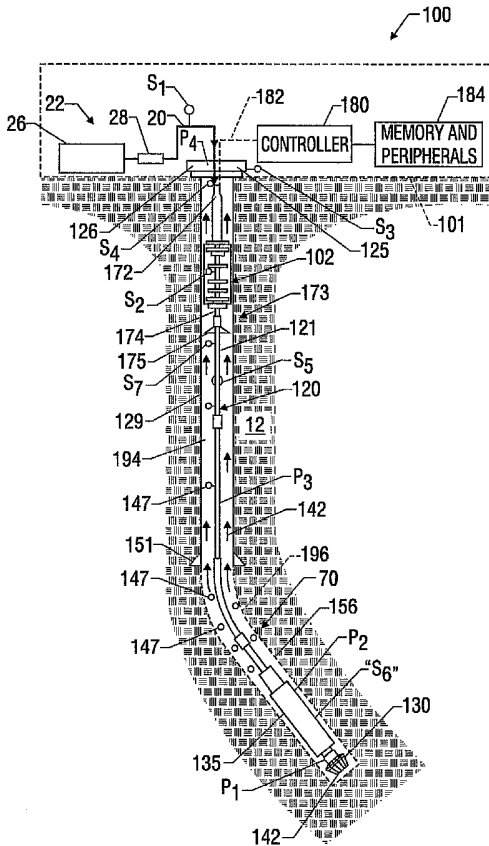

(57) Abstract: Methods and control systems are provided for a well-bore drilling system having an active differential pressure device (APD device) in fluid communication with a returning fluid. The APD Device creates a differential pressure across the device, which reduces the pressure below or downhole of the device. In embodiments, a control unit controls the APD Device in real time via a data transmission system. In one arrangement, the data transmission system includes data links formed by conductors associated with the drill string. The conductors, which may include electrical wires and/or fiber optic bundles, couple the control unit to the APD Device and other downhole tools such as sensors. In other arrangements, the data link can include data transmission stations that use acoustic, EM, and/or RF signals to transfer data. In still other embodiments, a mud pulse telemetry system can be used in transfer data and command signals.

WO 2006/099362 A1



For two-letter codes and other abbreviations, refer to the "Guidance Notes on Codes and Abbreviations" appearing at the beginning of each regular issue of the PCT Gazette.

**TITLE: CONTROL SYSTEMS AND METHODS FOR
REAL TIME DOWNHOLE PRESSURE
MANAGEMENT (ECDCONTROL)**

**INVENTORS: SVEN KRUEGER; VOLKER KRUEGER;
HARALD GRIMMER; ROGER FINCHER;
LARRY WATKINS; PETER ARONSTAM;
PETER FONTANA**

BACKGROUND OF THE INVENTION

1. Field of the Invention

[0001] This invention relates generally to oilfield wellbore drilling systems and more particularly to data links for systems that utilize active control of bottomhole pressure or equivalent circulating density.

2. Background of the Art

[0002] Oilfield wellbores are drilled by rotating a drill bit conveyed into the wellbore by a drill string. The drill string includes a drill pipe (tubing) that has at its bottom end a drilling assembly (also referred to as the "bottomhole assembly" or "BHA") that carries the drill bit for drilling the wellbore. The drill pipe is made of jointed pipes. Alternatively, coiled tubing may be utilized to carry the drilling of assembly. The drilling assembly usually includes a drilling motor or a "mud motor" that rotates the drill bit. The drilling assembly also includes a variety of sensors for taking measurements of a variety of drilling, formation and BHA parameters. A suitable drilling fluid (commonly referred to as the "mud") is supplied or pumped under pressure from a source at the

surface down the tubing. The drilling fluid drives the mud motor and then discharges at the bottom of the drill bit. The drilling fluid returns uphole via the annulus between the drill string and the wellbore inside and carries with it pieces of formation (commonly referred to as the "cuttings") cut or produced by the drill bit in drilling the wellbore.

[0003] For drilling wellbores under water (referred to in the industry as "offshore" or "subsea" drilling) tubing is provided at a work station (located on a vessel or platform). One or more tubing injectors or rigs are used to move the tubing into and out of the wellbore. In riser-type drilling, a riser, which is formed by joining sections of casing or pipe, is deployed between the drilling vessel and the wellhead equipment at the sea bottom and is utilized to guide the tubing to the wellhead. The riser also serves as a conduit for fluid returning from the wellhead to the sea surface.

[0004] During drilling, the drilling operator attempts to carefully control the fluid density at the surface so as to control pressure in the wellbore, including the bottomhole pressure. Typically, the operator maintains the hydrostatic pressure of the drilling fluid in the wellbore above the formation or pore pressure to avoid well blow-out. The density of the drilling fluid and the fluid flow rate largely determine the effectiveness of the drilling fluid to carry the cuttings to the surface. One important downhole parameter controlled during drilling is the bottomhole pressure, which in turn controls the equivalent circulating density ("ECD") of the fluid at the wellbore bottom.

[0005] This term, ECD, describes the condition that exists when the drilling mud in the well is circulated. The friction pressure caused by the fluid circulating through the open hole and the casing(s) on its way back to the

surface, causes an increase in the pressure profile along this path that is different from the pressure profile when the well is in a static condition (i.e., not circulating). In addition to the increase in pressure while circulating, there is an additional increase in pressure while drilling due to the introduction of drill solids into the fluid. This negative effect of the increase in pressure along the annulus of the well is an increase of the pressure which can fracture the formation at the shoe of the last casing. This can reduce the amount of hole that can be drilled before having to set an additional casing. In addition, the rate of circulation that can be achieved is also limited. Also, due to this circulating pressure increase, the ability to clean the hole is severely restricted. This condition is exacerbated when drilling an offshore well. In offshore wells, the difference between the fracture pressures in the shallow sections of the well and the pore pressures of the deeper sections is considerably smaller compared to on shore wellbores. This is due to the seawater gradient versus the gradient that would exist if there were soil overburden for the same depth.

[0006] In some drilling applications, it is desired to drill the wellbore at at-balance condition or at under-balanced condition. The term at-balance means that the pressure in the wellbore is maintained at or near the formation pressure. The under-balanced condition means that the wellbore pressure is below the formation pressure. These two conditions are desirable because the drilling fluid under such conditions does not penetrate into the formation, thereby leaving the formation virgin for performing formation evaluation tests and measurements. In order to be able to drill a well to a total wellbore depth at the bottomhole, ECD must be reduced or controlled. In subsea wells, one

approach is to use a mud- filled riser to form a subsea fluid circulation system utilizing the tubing, BHA, the annulus between the tubing and the wellbore and the mud filled riser, and then inject gas (or some other low density liquid) in the primary drilling fluid (typically in the annulus adjacent the BHA) to reduce the density of fluid downstream (i.e., in the remainder of the fluid circulation system). This so-called "dual density" approach is often referred to as drilling with compressible fluids.

[0007] Another method for changing the density gradient in a deepwater return fluid path has been proposed, but not used in practical application. This approach proposes to use a tank, such as an elastic bag, at the sea floor for receiving return fluid from the wellbore annulus and holding it at the hydrostatic pressure of the water at the sea floor. Independent of the flow in the annulus, a separate return line connected to the sea floor storage tank and a subsea lifting pump delivers the return fluid to the surface. Although this technique (which is referred to as "dual gradient" drilling) would use a single fluid, it would also require a discontinuity in the hydraulic gradient line between the sea floor storage tank and the subsea lifting pump. This requires close monitoring and control of the pressure at the subsea storage tank, subsea hydrostatic water pressure, subsea lifting pump operation and the surface pump delivering drilling fluids under pressure into the tubing for flow downhole. The level of complexity of the required subsea instrumentation and controls as well as the difficulty of deployment of the system has delayed (if not altogether prevented) the practical application of the "dual gradient" system.

[0008] Another approach is described in U.S. Patent Application No. 09/353,275, filed on July 14, 1999 and assigned to the assignee of the present application. The U.S. Patent Application No. 09/353,275 is incorporated herein by reference in its entirety. One embodiment of this application describes a riser less system wherein a centrifugal pump in a separate return line controls the fluid flow to the surface and thus the equivalent circulating density.

[0009] The present invention provides a wellbore system wherein the bottomhole pressure and hence the equivalent circulating density is controlled by creating a pressure differential at a selected location in the return fluid path with an active pressure differential device to reduce or control the bottomhole pressure. The present system is relatively easy to incorporate in new and existing systems.

SUMMARY OF THE INVENTION

[0010] In one aspect, the present invention provides wellbore systems for performing downhole wellbore operations for both land and offshore wellbores. Such drilling systems include a rig that moves an umbilical (e.g., drill string) into and out of the wellbore. A bottomhole assembly, carrying the drill bit, is attached to the bottom end of the drill string. A well control assembly or equipment on the well receives the bottomhole assembly and the tubing. A drilling fluid system supplies a drilling fluid into the tubing, which discharges at the drill bit and returns to the well control equipment carrying the drill cuttings via the annulus between the drill string and the wellbore. A riser dispersed between the wellhead equipment and the surface guides the drill string and provides a conduit for moving the returning fluid to the surface.

[0011] In one embodiment of the present invention, an active pressure differential device moves in the wellbore as the drill string is moved. In an alternative embodiment, the active differential pressure device is attached to the wellbore inside or wall and remains stationary relative to the wellbore during drilling. The device is operated during drilling, *i.e.*, when the drilling fluid is circulating through the wellbore, to create a pressure differential across the device. This pressure differential alters the pressure on the wellbore below or downhole of the device. The device may be controlled to reduce the bottomhole pressure by a certain amount, to maintain the bottomhole pressure at a certain value, or within a certain range. By severing

or restricting the flow through the device, the bottomhole pressure may be increased.

[0012] The system also includes downhole devices for performing a variety of functions. Exemplary downhole devices include devices that control the drilling flow rate and flow paths. For example, the system can include one or more flow-control devices that can stop the flow of the fluid in the drill string and/or the annulus. Such flow-control devices can be configured to direct fluid in drill string into the annulus and/or bypass return fluid around the APD device. Another exemplary downhole device can be configured for processing the cuttings (e.g., reduction of cutting size) and other debris flowing in the annulus. For example, a comminution device can be disposed in the annulus upstream of the APD device.

[0013] In a embodiment, sensors communicate with a controller via a telemetry system to maintain the wellbore pressure at a zone of interest at a selected pressure or range of pressures. The sensors are strategically positioned throughout the system to provide information or data relating to one or more selected parameters of interest such as drilling parameters, drilling assembly or BHA parameters, and formation or formation evaluation parameters. The controller for suitable for drilling operations preferably includes programs for maintaining the wellbore pressure at zone at under-balance condition, at at-balance condition or at over-balanced condition. The controller may be programmed to activate downhole devices according to programmed instructions or upon the occurrence of a particular condition.

[0014] Exemplary configurations for the APD Device and associated drive includes a moineau-type pump coupled to positive displacement motor/drive via a shaft assembly. Another exemplary configuration includes a turbine drive coupled to a centrifugal-type pump via a shaft assembly. Preferably, a high-pressure seal separates a supply fluid flowing through the motor from a return fluid flowing through the pump. In a preferred embodiment, the seal is configured to bear either or both of radial and axial (thrust) forces.

[0015] In still other configurations, a positive displacement motor can drive an intermediate device such as a hydraulic motor, which drives the APD Device. Alternatively, a jet pump can be used, which can eliminate the need for a drive/motor. Moreover, pumps incorporating one or more pistons, such as hammer pumps, may also be suitable for certain applications. In still other configurations, the APD Device can be driven by an electric motor. The electric motor can be positioned external to a drill string or formed integral with a drill string. In a preferred arrangement, varying the speed of the electrical motor directly controls the speed of the rotor in the APD device, and thus the pressure differential across the APD Device.

[0016] Bypass devices are provided to allow fluid circulation in the wellbore during tripping of the system, to control the operating set points of the APD Device and/or associated drive/motor, and to provide a discharge mechanism to relieve fluid pressure. For examples, the bypass devices can selectively channel fluid around the motor/drive and the APD Device and selectively discharge drilling fluid from the drill string into the annulus. In one arrangement, the bypass device for the pump can also function as a particle

bypass line for the APD device. Alternatively, a separate particle bypass can be used in addition to the pump bypass for such a function. Additionally, an annular seal (not shown) in certain embodiments can be disposed around the APD device to enable a pressure differential across the APD Device.

[0017] In certain embodiments, the present invention further provides a method of controlling pressure in a wellbore by controlling the APD Device to provide a wellbore pressure relative to a formation pressure parameter (*e.g.*, pore pressure, collapse pressure, fracture pressure, etc.) at a selected location in the wellbore. Operating parameters for the APD Device such as flow rate, speed, and pressure can be adjusted to cause the APD Device to provide a selected pressure differential in the return fluid. In one method, the operating parameter is set at the surface. In other methods, one or more of the operating parameters are adjusted during operation of the APD Device by a control unit. In one embodiment, a control unit operates an adjustable bypass that selectively diverts drilling fluid around a motor for the APD Device or the APD Device itself to thereby control the pressure differential caused by the pump. In other embodiments, the adjustable bypass can discharge fluid from the supply line to the annulus. The control unit can also control the APD Device in response to at least one determined parameter relating to a selected fluid in the wellbore such as flow rate, density, temperature, and pressure.

[0018] In embodiments, the APD Device is controlled in response to a measured pressure differential between an inlet of the APD Device and an outlet of the APD Device. For instance, a control unit controls the APD Device to provide a pre-determined pressure differential between the APD

Device inlet and outlet. In other arrangements, the APD device is controlled in response to a measured formation parameter such as pore pressure, fracture pressure, a geophysical property, a petrophysical property, and collapse pressure or a drilling parameter such as ROP, vibration, or flow rate.

[0019] The APD device can be configured to control pressure (or some other parameter) at the wellbore bottom or another location such as proximate to a casing shoe, at an open wellbore section uphole of the bottomhole assembly, or in a casing. For instance, the APD Device is controlled using wellbore pressure measurements to provide a specified pressure differential with respect to the pore pressure at an open hole adjacent a casing shoe. Such a pressure control arrangement may be advantageous when the APD Device is in a casing in the wellbore. The wellbore pressure at the casing shoe can, in such an arrangement, be controlled to provide an over-balance, an at-balance, or under-balance. Also, in certain methods, two or more APD Devices are used to provide a selected pressure profile in the wellbore.

[0020] Thus, in aspects, the present invention provides a system for controlling pressure in a wellbore drilled in a formation using a drill string having a bottomhole assembly at an end thereof and wherein a drilling fluid supplied under pressure to the drill string returns to the surface ("the return fluid"). In an illustrative embodiment, the system includes an Active Pressure Differential Device ("APD Device") in the return fluid, a control unit adapted to control the APD Device; and a data link connecting the APD Device to the control unit. The illustrative system can also include one or more sensors in the wellbore that measure one or more selected parameters of interest such

as wellbore pressure, a formation parameter, a drilling parameter, a BHA parameter or other parameter. The data link can also transmit data between the sensor and the control unit. Moreover, the control unit can be programmed to control the APD Device in response to sensor measurements. In one embodiment, the control unit is positioned at the surface. In other embodiments, the control unit is positioned at a downhole location. Control units can also be positioned at both locations. The control unit or units can be programmed to control under human supervision or in a closed loop fashion.

[0021] In one arrangement, the data link includes a conductor such as an electrical conductor and/or a fiber optic wire. The conductors can include cables or wires positioned in or along the drill string. In other arrangements, the data link can use a transmission media such as acoustical signals, radio frequency signals, electromagnetic signals, and/or mud pulse signals. Moreover, the data link can include a plurality of stations, each station adapted to relay signals uphole and/or downhole. Additionally, in some embodiments, the system can use two separate data links to couple the sensor(s) and the APD Device to the control unit. The separate data links can employ the same transmission media or use different media. For example, the data link between the APD device and the control unit can utilize conductors such as wired drill pipe or wired tubing and the data link between the sensor(s) and the control unit can use mud pulse signals.

[0022] The teachings of the present invention can also be utilized in non-drilling applications such as running liners. That is, the teachings of the present invention can be readily applied to any phase of the well construction process to control wellbore pressure.

[0023] Examples of the more important features of the invention have been summarized (albeit rather broadly) in order that the detailed description thereof that follows may be better understood and in order that the contributions they represent to the art may be appreciated. There are, of course, additional features of the invention that will be described hereinafter and which will form the subject of the claims appended hereto.

BRIEF DESCRIPTION OF THE DRAWINGS

[0024] For detailed understanding of the present invention, reference should be made to the following detailed description of the preferred embodiment, taken in conjunction with the accompanying drawing:

[0025] **Figure 1A** is a schematic illustration of one embodiment of a system using an active pressure differential device to manage pressure in a predetermined wellbore location;

[0026] **Figure 1B** graphically illustrates the effect of an operating active pressure differential device upon the pressure at a predetermined wellbore location;

[0027] **Figure 2** is a schematic elevation view of **Figure 1A** after the drill string and the active pressure differential device have moved a certain distance in the earth formation from the location shown in **Figure 1A**;

[0028] **Figure 3** is a schematic elevation view of an alternative embodiment of the wellbore system wherein the active pressure differential device is attached to the wellbore inside;

[0029] **Figures 4A-D** are schematic illustrations of one embodiment of an arrangement according to the present invention wherein a positive displacement motor is coupled to a positive displacement pump (the APD Device);

[0030] **Figures 5A and 5B** are schematic illustrations of one embodiment of an arrangement according to the present invention wherein a turbine drive is coupled to a centrifugal pump (the APD Device);

[0031] **Figure 6A** is a schematic illustration of an embodiment of an arrangement according to the present invention wherein an electric motor disposed on the outside of a drill string is coupled to an APD Device;

[0032] **Figure 6B** is a schematic illustration of an embodiment of an arrangement according to the present invention wherein an electric motor disposed within a drill string is coupled to an APD Device;

[0033] **Figure 7** schematically illustrates one embodiment of a control system for controlling an active pressure differential device in accordance with the present invention;

[0034] **Figure 8** is a flow chart illustrating an control system in accordance with one embodiment of the present invention;

[0035] **Figure 9A & B** schematically illustrate a wellbore pressure profile provided by a control system made in accordance with one embodiment of the present invention;

[0036] **Figure 10** schematically illustrate a signal, data communication system for surface control of pressure control system made in accordance with one embodiment of the present invention;

[0037] **Figure 11** schematically illustrate an exemplary data communication system for closed loop downhole control of pressure control system made in accordance with one embodiment of the present invention; and;

[0038] **Figure 12** schematically illustrate an exemplary data link utilizing telemetry stations made in accordance with one embodiment of the present invention.

DETAILED DESCRIPTION OF PREFERRED EMBODIMENTS

[0039] Referring initially to **Figure 1A**, there is schematically illustrated a system for performing one or more operations related to the construction, logging, completion or work-over of a hydrocarbon producing well. In particular, **Figure 1A** shows a schematic elevation view of one embodiment of a wellbore drilling system **100** for drilling wellbore **90** using conventional drilling fluid circulation. The drilling system **100** is a rig for land wells and includes a drilling platform **101**, which may be a drill ship or another suitable surface workstation such as a floating platform or a semi-submersible for offshore wells. For offshore operations, additional known equipment such as a riser and subsea wellhead will typically be used. To drill a wellbore **90**, well control equipment **125** (also referred to as the wellhead equipment) is placed above the wellbore **90**. The wellhead equipment **125** includes a blow-out-preventer stack **126** and a lubricator (not shown) with its associated flow control.

[0040] This system **100** further includes a well tool such as a drilling assembly or a bottomhole assembly ("BHA") **135** at the bottom of a suitable umbilical such as drill string or tubing **121** (such terms will be used interchangeably). In a preferred embodiment, the BHA **135** includes a drill bit **130** adapted to disintegrate rock and earth. The bit can be rotated by a surface rotary drive or a motor using pressurized fluid (e.g., mud motor) or an electrically driven motor. The tubing **121** can be formed partially or fully of drill pipe, metal or composite coiled tubing, liner, casing or other known members. Additionally, the tubing **121** can include data and power transmission carriers such fluid conduits, fiber optics, and metal conductors. Conventionally, the

tubing **121** is placed at the drilling platform **101**. To drill the wellbore **90**, the BHA **135** is conveyed from the drilling platform **101** to the wellhead equipment **125** and then inserted into the wellbore **90**. The tubing **121** is moved into and out of the wellbore **90** by a suitable tubing injection system.

[0041] During drilling, a drilling fluid from a surface mud system **22** is pumped under pressure down the tubing **121** (a "supply fluid"). The mud system **22** includes a mud pit or supply source **26** and one or more pumps **28**. In one embodiment, the supply fluid operates a mud motor in the BHA **135**, which in turn rotates the drill bit **130**. The drill string **121** rotation can also be used to rotate the drill bit **130**, either in conjunction with or separately from the mud motor. The drill bit **130** disintegrates the formation (rock) into cuttings **147**. The drilling fluid leaving the drill bit travels uphole through the annulus **194** between the drill string **121** and the wellbore wall or inside **196**, carrying the drill cuttings **147** therewith (a "return fluid"). The return fluid discharges into a separator (not shown) that separates the cuttings **147** and other solids from the return fluid and discharges the clean fluid back into the mud pit **26**. As shown in **Figure 1A**, the clean mud is pumped through the tubing **121** while the mud with cuttings **147** returns to the surface via the annulus **194** up to the wellhead equipment **125**.

[0042] Once the well **90** has been drilled to a certain depth, casing **129** with a casing shoe **151** at the bottom is installed. The drilling is then continued to drill the well to a desired depth that will include one or more production sections, such as section **155**. The section below the casing shoe **151** may not be cased until it is desired to complete the well, which leaves the bottom section of the well as an open hole, as shown by numeral **156**.

[0043] As noted above, the present invention provides a drilling system for controlling bottomhole pressure at a zone of interest designated by the numeral **155** and thereby the ECD effect on the wellbore. In one embodiment of the present invention, to manage or control the pressure at the zone **155**, an active pressure differential device ("APD Device") **170** is fluidically coupled to return fluid downstream of the zone of interest **155**. The active pressure differential device is a device that is capable of creating a pressure differential " ΔP " across the device. This controlled pressure drop reduces the pressure upstream of the APD Device **170** and particularly in zone **155**.

[0044] The system **100** also includes downhole devices that separately or cooperatively perform one or more functions such as controlling the flow rate of the drilling fluid and controlling the flow paths of the drilling fluid. For example, the system **100** can include one or more flow-control devices that can stop the flow of the fluid in the drill string and/or the annulus **194**. **Figure 1A** shows an exemplary flow-control device **173** that includes a device **174** that can block the fluid flow within the drill string **121** and a device **175** that blocks can block fluid flow through the annulus **194**. The device **173** can be activated when a particular condition occurs to insulate the well above and below the flow-control device **173**. For example, the flow-control device **173** may be activated to block fluid flow communication when drilling fluid circulation is stopped so as to isolate the sections above and below the device **173**, thereby maintaining the wellbore below the device **173** at or substantially at the pressure condition prior to the stopping of the fluid circulation.

[0045] The flow-control devices **174, 175** can also be configured to selectively control the flow path of the drilling fluid. For example, the flow-control device **174** in the drill pipe **121** can be configured to direct some or all of the fluid in drill string **121** into the annulus **194**. Moreover, one or both of the flow-control devices **174, 175** can be configured to bypass some or all of the return fluid around the APD device **170**. Such an arrangement may be useful, for instance, to assist in lifting cuttings to the surface. The flow-control device **173** may include check-valves, packers and any other suitable device. Such devices may automatically activate upon the occurrence of a particular event or condition.

[0046] The system **100** also includes downhole devices for processing the cuttings (e.g., reduction of cutting size) and other debris flowing in the annulus **194**. For example, a comminution device **176** can be disposed in the annulus **194** upstream of the APD device **170** to reduce the size of entrained cutting and other debris. The comminution device **176** can use known members such as blades, teeth, or rollers to crush, pulverize or otherwise disintegrate cuttings and debris entrained in the fluid flowing in the annulus **194**. The comminution device **176** can be operated by an electric motor, a hydraulic motor, by rotation of drill string or other suitable means. The comminution device **176** can also be integrated into the APD device **170**. For instance, if a multi-stage turbine is used as the APD device **170**, then the stages adjacent the inlet to the turbine can be replaced with blades adapted to cut or shear particles before they pass through the blades of the remaining turbine stages.

[0047] Sensors S_{1-n} are strategically positioned throughout the system **100** to provide information or data relating to one or more selected parameters of interest (pressure, flow rate, temperature). In a preferred embodiment, the downhole devices and sensors S_{1-n} communicate with a controller **180** via a telemetry system (not shown). Using data provided by the sensors S_{1-n} , the controller **180** maintains the wellbore pressure at zone **155** at a selected pressure or range of pressures. The controller **180** maintains the selected pressure by controlling the APD device **170** (e.g., adjusting amount of energy added to the return fluid line) and/or the downhole devices (e.g., adjusting flow rate through a restriction such as a valve).

[0048] When configured for drilling operations, the sensors S_{1-n} provide measurements relating to a variety of drilling parameters, such as fluid pressure, fluid flow rate, rotational speed of pumps and like devices, temperature, weight-on bit, rate of penetration, etc., drilling assembly or BHA parameters, such as vibration, stick slip, RPM, inclination, direction, BHA location, etc. and formation or formation evaluation parameters commonly referred to as measurement-while-drilling parameters such as resistivity, acoustic, nuclear, NMR, etc. One preferred type of sensor is a pressure sensor for measuring pressure at one or more locations. Referring still to **Fig. 1A**, pressure sensor P_1 provides pressure data in the BHA, sensor P_2 provides pressure data in the annulus, pressure sensor P_3 in the supply fluid, and pressure sensor P_4 provides pressure data at the surface. Other pressure sensors may be used to provide pressure data at any other desired place in the system **100**. Additionally, the system **100** includes fluid flow

sensors such as sensor **V** that provides measurement of fluid flow at one or more places in the system.

[0049] Further, the status and condition of equipment as well as parameters relating to ambient conditions (e.g., pressure and other parameters listed above) in the system **100** can be monitored by sensors positioned throughout the system **100**: exemplary locations including at the surface (**S1**), at the APD device **170** (**S2**), at the wellhead equipment **125** (**S3**), in the supply fluid (**S4**), along the tubing **121** (**S5**), at the well tool **135** (**S6**), in the return fluid upstream of the APD device **170** (**S7**), and in the return fluid downstream of the APD device **170** (**S8**). It should be understood that other locations may also be used for the sensors **S_{1-n}**.

[0050] The controller **180** for suitable for drilling operations preferably includes programs for maintaining the wellbore pressure at zone **155** at under-balance condition, at at-balance condition or at over-balanced condition. The controller **180** includes one or more processors that process signals from the various sensors in the drilling assembly and also controls their operation. The data provided by these sensors **S_{1-n}** and control signals transmitted by the controller **180** to control downhole devices such as devices **173-176** are communicated by a suitable two-way telemetry system (not shown). A separate processor may be used for each sensor or device. Each sensor may also have additional circuitry for its unique operations. The controller **180**, which may be either downhole or at the surface, is used herein in the generic sense for simplicity and ease of understanding and not as a limitation because the use and operation of such controllers is known in the art. The controller **180** preferably contains one or more microprocessors or

micro-controllers for processing signals and data and for performing control functions, solid state memory units for storing programmed instructions, models (which may be interactive models) and data, and other necessary control circuits. The microprocessors control the operations of the various sensors, provide communication among the downhole sensors and provide two-way data and signal communication between the drilling assembly 30, downhole devices such as devices 173-175 and the surface equipment via the two-way telemetry. In other embodiments, the controller 180 can be a hydro-mechanical device that incorporates known mechanisms (valves, biased members, linkages cooperating to actuate tools under, for example, preset conditions).

[0051] For convenience, a single controller 180 is shown. It should be understood, however, that a plurality of controllers 180 can also be used. For example, a downhole controller can be used to collect, process and transmit data to a surface controller, which further processes the data and transmits appropriate control signals downhole. Other variations for dividing data processing tasks and generating control signals can also be used.

[0052] In general, however, during operation, the controller 180 receives the information regarding a parameter of interest and adjusts one or more downhole devices and/or APD device 170 to provide the desired pressure or range or pressure in the vicinity of the zone of interest 155. For example, the controller 180 can receive pressure information from one or more of the sensors (S_1-S_n) in the system 100. The controller 180 may control the APD Device 170 in response to one or more of: pressure, fluid flow, a formation characteristic, a wellbore characteristic and a fluid

characteristic, a surface measured parameter or a parameter measured in the drill string. The controller **180** determines the ECD and adjusts the energy input to the APD device **170** to maintain the ECD at a desired or predetermined value or within a desired or predetermined range. The wellbore system **100** thus provides a closed loop system for controlling the ECD in response to one or more parameters of interest during drilling of a wellbore. This system is relatively simple and efficient and can be incorporated into new or existing drilling systems and readily adapted to support other well construction, completion, and work-over activities.

[0053] In the embodiment shown in **Figure 1A**, the APD Device **170** is shown as a turbine attached to the drill string **121** that operates within the annulus **194**. Other embodiments, described in further detail below can include centrifugal pumps, positive displacement pump, jet pumps and other like devices. During drilling, the APD Device **170** moves in the wellbore **90** along with the drill string **121**. The return fluid can flow through the APD Device **170** whether or not the turbine is operating. However, the APD Device **170**, when operated creates a differential pressure there across.

[0054] As described above, the system **100** in one embodiment includes a controller **180** that includes a memory and peripherals **184** for controlling the operation of the APD Device **170**, the devices **173-176**, and/or the bottomhole assembly **135**. In **Figure 1A**, the controller **180** is shown placed at the surface. It, however, may be located adjacent the APD Device **170**, in the BHA **135** or at any other suitable location. The controller **180** controls the APD Device to create a desired amount of ΔP across the device, which alters the bottomhole pressure accordingly. Alternatively, the controller

180 may be programmed to activate the flow-control device **173** (or other downhole devices) according to programmed instructions or upon the occurrence of a particular condition. Thus, the controller **180** can control the APD Device in response to sensor data regarding a parameter of interest, according to programmed instructions provided to said APD Device, or in response to instructions provided to said APD Device from a remote location. The controller **180** can, thus, operate autonomously or interactively.

[0055] During drilling, the controller **180** controls the operation of the APD Device to create a certain pressure differential across the device so as to alter the pressure on the formation or the bottomhole pressure. The controller **180** may be programmed to maintain the wellbore pressure at a value or range of values that provide an under-balance condition, an at-balance condition or an over-balanced condition. In one embodiment, the differential pressure may be altered by altering the speed of the APD Device. For instance, the bottomhole pressure may be maintained at a pre-selected value or within a selected range relative to a parameter of interest such as the formation pressure. The controller **180** may receive signals from one or more sensors in the system **100** and in response thereto control the operation of the APD Device to create the desired pressure differential. The controller **180** may contain pre-programmed instructions and autonomously control the APD Device or respond to signals received from another device that may be remotely located from the APD Device.

[0056] **Figure 1B** graphically illustrates the ECD control provided by the above-described embodiment of the present invention and references **Figure 1A** for convenience. **Figure 1A** shows the APD device **170** at a depth

D1 and a representative location in the wellbore in the vicinity of the well tool **30** at a lower depth **D2**. **Figure 1B** provides a depth versus pressure graph having a first curve **C1** representative of a pressure gradient before operation of the system **100** and a second curve **C2** representative of a pressure gradients during operation of the system **100**. Curve **C3** represents a theoretical curve wherein the ECD condition is not present; *i.e.*, when the well is static and not circulating and is free of drill cuttings. It will be seen that a target or selected pressure at depth **D2** under curve **C3** cannot be met with curve **C1**. Advantageously, the system **100** reduces the hydrostatic pressure at depth **D1** and thus shifts the pressure gradient as shown by curve **C3**, which can provide the desired predetermined pressure at depth **D2**. In most instances, this shift is roughly the pressure drop provided by the APD device **170**.

[0057] **Figure 2** shows the drill string after it has moved the distance "d" shown by $t_1 - t_2$. Since the APD Device **170** is attached to the drill string **121**, the APD Device **170** also is shown moved by the distance d.

[0058] As noted earlier and shown in **Figure 2**, an APD Device **170a** may be attached to the wellbore in a manner that will allow the drill string **121** to move while the APD Device **170a** remains at a fixed location. **Figure 3** shows an embodiment wherein the APD Device is attached to the wellbore inside and is operated by a suitable device **172a**. Thus, the APD device can be attached to a location stationary relative to said drill string such as a casing, a liner, the wellbore annulus, a riser, or other suitable wellbore equipment. The APD Device **170a** is preferably installed so that it is in a

cased upper section **129**. The device **170a** is controlled in the manner described with respect to the device **170** (Fig 1A).

[0059] Referring now to **Figures 4A-D**, there is schematically illustrated one arrangement wherein a positive displacement motor/drive **200** is coupled to a moineau-type pump **220** via a shaft assembly **240**. The motor **200** is connected to an upper string section **260** through which drilling fluid is pumped from a surface location. The pump **220** is connected to a lower drill string section **262** on which the bottomhole assembly (not shown) is attached at an end thereof. The motor **200** includes a rotor **202** and a stator **204**. Similarly, the pump **220** includes a rotor **222** and a stator **224**. The design of moineau-type pumps and motors are known to one skilled in the art and will not be discussed in further detail.

[0060] The shaft assembly **240** transmits the power generated by the motor **200** to the pump **220**. One preferred shaft assembly **240** includes a motor flex shaft **242** connected to the motor rotor **202**, a pump flex shaft **244** connected to the pump rotor **224**, and a coupling shaft **246** for joining the first and second shafts **242** and **244**. In one arrangement, a high-pressure seal **248** is disposed about the coupling shaft **246**. As is known, the rotors for moineau-type motors/pump are subject to eccentric motion during rotation. Accordingly, the coupling shaft **246** is preferably articulated or formed sufficiently flexible to absorb this eccentric motion. Alternately or in combination, the shafts **242**, **244** can be configured to flex to accommodate eccentric motion. Radial and axial forces can be borne by bearings **250** positioned along the shaft assembly **240**. In a preferred embodiment, the seal **248** is configured to bear either or both of radial and axial (thrust) forces.

In certain arrangements, a speed or torque converter **252** can be used to convert speed/torque of the motor **200** to a second speed/torque for the pump **220**. By speed/torque converter it is meant known devices such as variable or fixed ratio mechanical gearboxes, hydrostatic torque converters, and a hydrodynamic converters. It should be understood that any number of arrangements and devices can be used to transfer power, speed, or torque from the motor **200** to the pump **220**. For example, the shaft assembly **240** can utilize a single shaft instead of multiple shafts.

[0061] As described earlier, a comminution device can be used to process entrained cutting in the return fluid before it enters the pump **200**. Such a comminution device (**Figure 1A**) can be coupled to the drive **200** or pump **220** and operated thereby. For instance, one such comminution device or cutting mill **270** can include a shaft **272** coupled to the pump rotor **224**. The shaft **272** can include a conical head or hammer element **274** mounted thereon. During rotation, the eccentric motion of the pump rotor **224** will cause a corresponding radial motion of the shaft head **274**. This radial motion can be used to resize the cuttings between the rotor and a comminution device housing **276**.

[0062] The **Figures 4A-D** arrangement also includes a supply flow path **290** to carry supply fluid from the device **200** to the lower drill string section **262** and a return flow path **292** to channel return fluid from the casing interior or annulus into and out of the pump **220**. The high pressure seal **248** is interposed between the flow paths **290** and **292** to prevent fluid leaks, particularly from the high pressure fluid in the supply flow path **290** into the return flow path **292**. The seal **248** can be a high-pressure seal, a

hydrodynamic seal or other suitable seal and formed of rubber, an elastomer, metal or composite.

[0063] Additionally, bypass devices are provided to allow fluid circulation during tripping of the downhole devices of the system **100 (Fig. 1A)**, to control the operating set points of the motor **200** and pump **220**, and to provide safety pressure relief along either or both of the supply flow path **290** and the return flow path **292**. Exemplary bypass devices include a circulation bypass **300**, motor bypass **310**, and a pump bypass **320**.

[0064] The circulation bypass **300** selectively diverts supply fluid into the annulus **194 (Fig. 1A)** or casing **C** interior. The circulation bypass **300** is interposed generally between the upper drill string section **260** and the motor **200**. One preferred circulation bypass **300** includes a biased valve member **302** that opens when the flow-rate drops below a predetermined valve. When the valve **302** is open, the supply fluid flows along a channel **304** and exits at ports **306**. More generally, the circulation bypass can be configured to actuate upon receiving an actuating signal and/or detecting a predetermined value or range of values relating to a parameter of interest (e.g., flow rate or pressure of supply fluid or operating parameter of the bottomhole assembly). The circulation bypass **300** can be used to facilitate drilling operations and to selective increase the pressure/flow rate of the return fluid.

[0065] The motor bypass **310** selectively channels conveys fluid around the motor **200**. The motor bypass **310** includes a valve **312** and a passage **314** formed through the motor rotor **202**. A joint **316** connecting the motor rotor **202** to the first shaft **242** includes suitable passages (not shown)

that allow the supply fluid to exit the rotor passage **314** and enter the supply flow path **290**. Likewise, a pump bypass **320** selectively conveys fluid around the pump **220**. The pump bypass includes a valve and a passage formed through the pump rotor **222** or housing. The pump bypass **320** can also be configured to function as a particle bypass line for the APD device. For example, the pump bypass can be adapted with known elements such as screens or filters to selectively convey cuttings or particles entrained in the return fluid that are greater than a predetermined size around the APD device. Alternatively, a separate particle bypass can be used in addition to the pump bypass for such a function. Alternately, a valve (not shown) in a pump housing **225** can divert fluid to a conduit parallel to the pump **220**. Such a valve can be configured to open when the flow rate drops below a predetermined value. Further, the bypass device can be a design internal leakage in the pump. That is, the operating point of the pump **220** can be controlled by providing a preset or variable amount of fluid leakage in the pump **220**. Additionally, pressure valves can be positioned in the pump **220** to discharge fluid in the event an overpressure condition or other predetermined condition is detected.

[0066] Additionally, an annular seal **299** in certain embodiments can be disposed around the APD device to direct the return fluid to flow into the pump **220** (or more generally, the APD device) and to allow a pressure differential across the pump **220**. The seal **299** can be a solid or pliant ring member, an expandable packer type element that expands/contracts upon receiving a command signal, or other member that substantially prevents the return fluid from flowing between the pump **220** (or more generally, the APD

device) and the casing or wellbore wall. In certain applications, the clearance between the APD device and adjacent wall (either casing or wellbore) may be sufficiently small as to not require an annular seal.

[0067] During operation, the motor **200** and pump **220** are positioned in a well bore location such as in a casing **C**. Drilling fluid (the supply fluid) flowing through the upper drill string section **260** enters the motor **200** and causes the rotor **202** to rotate. This rotation is transferred to the pump rotor **222** by the shaft assembly **240**. As is known, the respective lobe profiles, size and configuration of the motor **200** and the pump **220** can be varied to provide a selected speed or torque curve at given flow-rates. Upon exiting the motor **200**, the supply fluid flows through the supply flow path **290** to the lower drill string section **262**, and ultimately the bottomhole assembly (not shown). The return fluid flows up through the wellbore annulus (not shown) and casing **C** and enters the cutting mill **270** via a inlet **293** for the return flow path **292**. The flow goes through the cutting mill **270** and enters the pump **220**. In this embodiment, the controller **180** (**Fig. 1A**) can be programmed to control the speed of the motor **200** and thus the operation of the pump **220** (the APD Device in this instance).

[0068] It should be understood that the above-described arrangement is merely one exemplary use of positive displacement motors and pumps. For example, while the positive displacement motor and pump are shown in structurally in series in **Figures 4A-D**, a suitable arrangement can also have a positive displacement motor and pump in parallel. For example, the motor can be concentrically disposed in a pump.

[0069] Referring now to **Figures 5A-B**, there is schematically illustrated one arrangement wherein a turbine drive **350** is coupled to a centrifugal-type pump **370** via a shaft assembly **390**. The turbine **350** includes stationary and rotating blades **354** and radial bearings **402**. The centrifugal-type pump **370** includes a housing **372** and multiple impeller stages **374**. The design of turbines and centrifugal pumps are known to one skilled in the art and will not be discussed in further detail.

[0070] The shaft assembly **390** transmits the power generated by the turbine **350** to the centrifugal pump **370**. One preferred shaft assembly **350** includes a turbine shaft **392** connected to the turbine blade assembly **354**, a pump shaft **394** connected to the pump impeller stages **374**, and a coupling **396** for joining the turbine and pump shafts **392** and **394**.

[0071] The **Figure 5A-B** arrangement also includes a supply flow path **410** for channeling supply fluid shown by arrows designated **416** and a return flow path **418** to channel return fluid shown by arrows designated **424**. The supply flow path **410** includes an inlet **412** directing supply fluid into the turbine **350** and an axial passage **413** that conveys the supply fluid exiting the turbine **350** to an outlet **414**. The return flow path **418** includes an inlet **420** that directs return fluid into the centrifugal pump **370** and an outlet **422** that channels the return fluid into the casing **C** interior or wellbore annulus. A high pressure seal **400** is interposed between the flow paths **410** and **418** to reduce fluid leaks, particularly from the high pressure fluid in the supply flow path **410** into the return flow path **418**. A small leakage rate is desired to cool and lubricate the axial and radial bearings. Additionally, a bypass **426** can be provided to divert supply fluid from the turbine **350**. Moreover, radial and axial

forces can be borne by bearing assemblies **402** positioned along the shaft assembly **390**. Preferably a comminution device **373** is provided to reduce particle size entering the centrifugal pump **370**. In a preferred embodiment, one of the impeller stages is modified with shearing blades or elements that shear entrained particles to reduce their size. In certain arrangements, a speed or torque converter **406** can be used to convert a first speed/torque of the motor **350** to a second speed/torque for the centrifugal pump **370**. It should be understood that any number of arrangements and devices can be used to transfer power, speed, or torque from the turbine **350** to the pump **370**. For example, the shaft assembly **390** can utilize a single shaft instead of multiple shafts.

[0072] It should be appreciated that a positive displacement pump need not be matched with only a positive displacement motor, or a centrifugal pump with only a turbine. In certain applications, operational speed or space considerations may lend itself to an arrangement wherein a positive displacement drive can effectively energize a centrifugal pump or a turbine drive energize a positive displacement pump. It should also be appreciated that the present invention is not limited to the above-described arrangements. For example, a positive displacement motor can drive an intermediate device such as an electric motor or hydraulic motor provided with an encapsulated clean hydraulic reservoir. In such an arrangement, the hydraulic motor (or produced electric power) drives the pump. These arrangements can eliminate the leak paths between the high-pressure supply fluid and the return fluid and therefore eliminates the need for high-pressure seals. Alternatively, a jet pump can be used. In an exemplary arrangement, the supply fluid is divided

into two streams. The first stream is directed to the BHA. The second stream is accelerated by a nozzle and discharged with high velocity into the annulus, thereby effecting a reduction in annular pressure. Pumps incorporating one or more pistons, such as hammer pumps, may also be suitable for certain applications.

[0073] Referring now to **Figure 6A**, there is schematically illustrated one arrangement wherein an electrically driven pump assembly **500** includes a motor **510** that is at least partially positioned external to a drill string **502**. In a conventional manner, the motor **510** is coupled to a pump **520** via a shaft assembly **530**. A supply flow path **504** conveys supply fluid designated with arrow **505** and a return flow path **506** conveys return fluid designated with arrow **507**. As can be seen, the **Figure 6A** arrangement does not include leak paths through which the high-pressure supply fluid **505** can invade the return flow path **506**. Thus, there is no need for high pressures seals.

[0074] In one embodiment, the motor **510** includes a rotor **512**, a stator **514**, and a rotating seal **516** that protects the coils **512** and stator **514** from drilling fluid and cuttings. In one embodiment, the stator **514** is fixed on the outside of the drill string **502**. The coils of the rotor **512** and stator **514** are encapsulated in a material or housing that prevents damage from contact with wellbore fluids. Preferably, the motor **510** interiors are filled with a clean hydraulic fluid. In another embodiment not shown, the rotor is positioned within the flow of the return fluid, thereby eliminating the rotating seal. In such an arrangement, the stator can be protected with a tube filled with clean hydraulic fluid for pressure compensation.

[0075] Referring now to **Figure 6B**, there is schematically illustrated one arrangement wherein an electrically driven pump **550** includes a motor **570** that is at least partially formed integral with a drill string **552**. In a conventional manner, the motor **570** is coupled to a pump **590** via a shaft assembly **580**. A supply flow path **554** conveys supply fluid designated with arrow **556** and a return flow path **558** conveys return fluid designated with arrow **560**. As can be seen, the **Figure 6B** arrangement does not include leak paths through which the high-pressure supply fluid **556** can invade the return flow path **558**. Thus, there is no need for high pressures seals.

[0076] It should be appreciated that an electrical drive provides a relatively simple method for controlling the APD Device. For instance, varying the speed of the electrical motor will directly control the speed of the rotor in the APD device, and thus the pressure differential across the APD Device. Further, in either of the **Figure 6A or 6B** arrangements, the pump **520** and **590** can be any suitable pump, and is preferably a multi-stage centrifugal-type pump. Moreover, positive displacement type pumps such a screw or gear type or moineau-type pumps may also be adequate for many applications. For example, the pump configuration may be single stage or multi-stage and utilize radial flow, axial flow, or mixed flow. Additionally, as described earlier, a comminution device positioned downhole of the pumps **520** and **590** can be used to reduce the size of particles entrained in the return fluid.

[0077] It will be appreciated that many variations to the above-described embodiments are possible. For example, a clutch element can be added to the shaft assembly connecting the drive to the pump to selectively couple and uncouple the drive and pump. Further, in certain applications, it

may be advantages to utilize a non-mechanical connection between the drive and the pump. For instance, a magnetic clutch can be used to engage the drive and the pump. In such an arrangement, the supply fluid and drive and the return fluid and pump can remain separated. The speed/torque can be transferred by a magnetic connection that couples the drive and pump elements, which are separated by a tubular element (e.g., drill string). Additionally, while certain elements have been discussed with respect to one or more particular embodiments, it should be understood that the present invention is not limited to any such particular combinations. For example, elements such as shaft assemblies, bypasses, comminution devices and annular seals discussed in the context of positive displacement drives can be readily used with electric drive arrangements. Other embodiments within the scope of the present invention that are not shown include a centrifugal pump that is attached to the drill string. The pump can include a multi-stage impeller and can be driven by a hydraulic power unit, such as a motor. This motor may be operated by the drilling fluid or by any other suitable manner. Still another embodiment not shown includes an APD Device that is fixed to the drill string, which is operated by the drill string rotation. In this embodiment, a number of impellers are attached to the drill string. The rotation of the drill string rotates the impeller that creates a differential pressure across the device.

[0078] It should be appreciated that the embodiments of the present invention heretofore described provide enhanced control of wellbore pressures. Methods of controlling these and other embodiments of the present invention can also enhance drilling activities.

[0079] One exemplary method of control involves pre-setting one or more operating parameters of an APD Device such that the APD Device causes a selected pressure differential in the return fluid. Exemplary operating parameters include the flow rate of drilling fluid through the APD Device, the rotational speed of the APD Device, and the operating pressure of the APD Device. Suitable devices for exerting control over these operating parameters include bypass valves, speed governors, pressure regulators, relief valves, etc. These devices can be positioned to control operation of the motor and/or the pump. Of course, other factors such as drilling fluid properties and operating pressure and flow rates of the drilling fluid will also have to be considered with setting the operating parameter(s).

[0080] Referring back to **Figs. 1A, 4A-D**, in one exemplary previously described arrangement, the motor bypass **310** selectively channels conveys fluid around the motor **200**. The motor bypass **310** includes a valve **312** and a passage **314** formed through the motor rotor **202** and allows a selected amount of drilling fluid to bypass the positive displacement motor, which directly controls the speed of the motor and the pump. Because the speed of the motor **200** and the pump and the output pressure differential of the pump **220** are directly related, appropriate selection of the flow rate into the valve **312** and line **314** can provide control over the pressure differential caused by the pump **220**. In one arrangement, a formation pressure parameter such as the pore pressure, the collapse pressure, and/or the fracture pressure are determined using known formation evaluation tools (e.g., formation fluid pressure testers, pressure subs, leak off testers, etc.). These formation pressure parameters can be determined at a casing shoe

151 (Fig. 1), at a location proximate to the wellbore bottom and/or any intermediate location. Next, the operating parameter (e.g., flow rate) is selected such that the pump output pressure differential effects a desired condition in the well (e.g., an over-balance, an at-balance, an underbalance) at a selected location in the well (e.g., at wellbore bottom, at the casing shoe, or a intermediate location). Thereafter, the APD device **170** is positioned in the wellbore and operated. Under a set operating condition (e.g., surface determined drilling fluid weight, pressure and flow rate), the APD Device **170** will produce a substantially constant pressure differential in the return fluid.

[0081] Referring now to Figure 7, there is shown one exemplary method for providing active control over the APD Device. This can be advantageous when the pressure in the wellbore annulus is not constant. Common activities and occurrences that can lead to transient pressure behavior in the wellbore include start up and shut down of the pumps, swab and surge effects while tripping, variable cutting load, temperature, tool performance change, variable flow rate change, and heave. Furthermore the desired pressure reduction might change during drilling operation. Thus, active control (e.g., adjustment, modulation, etc.) may be desirable to efficiently management wellbore pressure during such dynamic events and during normal drilling operations.

[0082] In **Fig. 7**, there is schematically shown a motor **700** coupled to an APD Device such as a pump **702**. The motor **700** is energized by pressurized drilling fluid flowing in a tubing **704** and the pump **702** is positioned in the return fluid flowing through the annulus **706**. An adjustable bypass **708** runs parallel to the motor **700** and includes a flow control

assembly such as a nozzle that is manipulated by an actuator responsive to control signals. The adjustable bypass **708** diverts a selected amount of drilling fluid from uphole of the motor **700** and conveys it to a location downhole of the motor **700**. In other arrangements, the adjustable bypass **708** can divert the fluid to the annulus **706**. In other arrangements the bypass can be positioned on the pump side to selectively divert fluid around the pump **702**. On the return side, a first pressure sensor **710** is positioned uphole (e.g., at an inlet) of the pump **702**, and a second pressure sensor **712** is positioned uphole (e.g., at an outlet) of the pump **702**. The control unit **714** receives pressure measurement data from the first and second sensors **710,712** and is operatively coupled to the adjustable bypass line **708**. It can also receive flow rate data from one or more flow rate sensors **716** in the supply line **704**. The control unit **714** can have a memory module programmed with instructions and algorithms for computing a control signal for the adjustable bypass.

[0083] In one mode of operation, the control unit **714** is programmed with an operating norm for the pressure differential provided by the pump **702** during operation. This norm can be a selected value for pressure differential, a minimum pressure differential, a maximum pressure differential, and/or a range of pressure differentials. Thus, if the pressure measurements from the first and second pressure sensors **710,712** indicate an out-of-norm operating condition, the control unit **714** issues appropriate control signals to adjustable bypass **708** to return the operating condition to established norms. The signals can, for example, cause an increase in the flow rate through the adjustable bypass **708** to reduce motor speed and thereby reduce the pressure differential caused by the pump **702**. In embodiments where the

bypass **708** is positioned on the return side, the flow rate across the pump **702** can be increased or decreased as needed to control the pressure differential. The control unit **714** can also be programmed with instructions for handling transient conditions such as a gas kick or other condition that can destabilize the wellbore environment. In some embodiments, the control unit **714** can have a dynamically updatable memory that utilizes well specific data (e.g., formation evaluation data) to optimize control of the motor **700** and pump **702**.

[0084] Referring now to **Fig. 8**, there is schematically illustrated one embodiment of a pressure control system that may be employed with one or more of the previously described wellbore pressure control systems. The system includes a downhole control unit **800** adapted to at least manage pressure in the wellbore. The control unit **800** utilizes pre-programmed data as well as data measured during drilling including: formation pressure parameters **802** such as pore pressure, collapse pressure and fracture pressure that have been previously measured or are measured during drilling; wellbore pressure **804** measured at selected locations such as the casing shoe or wellbore bottom; wellbore fluid parameters **806** such as density, flow rate, viscosity, etc.; formation evaluation parameters **808** such as resistivity, porosity, gamma ray, nuclear, etc.; and drilling parameters **810** such as ROP and flow rates. Formation evaluation data **812** either from an offset well or MWD data from the drilled well can also be made available to the control unit **800**. The control unit **800** can also include processing modules having programmed instructions. These instructions can be used to make determinations as to the appropriate adjustments that must be made to

maintain a current operating condition, create a different operating condition, alleviate a safety concern or dysfunction, and/or optimize drilling. Exemplary processing modules include a pressure control module **814** for maintaining wellbore pressures such that the formation is not damaged or does not cause an unsafe wellbore condition, a drilling optimizing module **816** for maintaining drilling at optimal ROP or extended life, and a module **818** for maintaining the health of the drill string and BHA.

[0085] The control unit **800** can be configured to control one or more downhole tools including one or more APD Devices **818,820**, one or more flow control devices **822**, and BHA devices such as the drilling motor **824**, and **826**. It should be understood that these described devices are merely illustrative of the devices can be controlled by the control unit **800**. In one mode of operation, the control unit **800** operates in a closed loop fashion. For example, the control unit **800** periodically receives wellbore pressure data from one or more pressure sensors. This pressure data or extrapolation / interpolations of the pressure data can be used to determine the pressure at selected locations in the wellbore. The control unit **800** can utilize the modules **814,816,818** to determine whether the pressure data requires adjustment of downhole operating conditions and, if so, the values to be used to make the necessary adjustments. The values are converted to control signals **830** that are transmitted to one or more downhole devices **820-828**. In another mode of operation, the control unit **800** transmits data to a surface controller **832** which may be human and/or a computer. The data can be digitized and pre-processed data as well as recommended actions (advice). The surface controller **832** can take appropriate measures such as adjusting

the operating set points of surface pumps or other steps (e.g., altering WOB, altering rotation speed, etc.). In such a mode, the control unit **800** can be adapted to receive and execute command signals from the surface.

[0086] Referring now to **Fig. 9A** and **9B** there is shown one arrangement for controlling a system for controlling wellbore pressure. **Fig. 9A** illustrates an elevation view of an APD Device **850** positioned in a casing **852** proximate to a casing shoe **854**. A drill string **856** extends downward into an open hole **858** below the casing **852** and terminates at a wellbore bottom **860**. In one pressure management arrangement, a pore pressure is determined for the open hole adjacent the casing shoe **854**. As is known, the pore pressure represents the pressure of the fluid in the formation. A wellbore pressure higher than the pore pressure is generally desirable because such a wellbore pressure will prevent the formation fluids from flowing into the wellbore. Also, drilling fluid can be circulated (without drilling the formation) so that the wellbore pressure at the casing shoe **854** can be determined using a tool such as a pressure sub. **Fig. 9B** illustrates an exemplary pressure gradient for the **Fig. 9A** embodiment. Line **861** represents the pore pressure of the formation, line **862** represents the fracture pressure of the formation, line **864** represents the collapse pressure of the formation, and line **866** represents the total pressure or ECD of the drilling fluid. As shown, at depth **L2**, the ECD pressure line would exceed the fracture pressure—which as discussed previously represents a barrier to further drilling. Thus, it is advantageous to shift line **866** to the left (*i.e.*, reduce its magnitude) in order to continue drilling, the shifted line shown as a dashed line **868**. It should be noted, however, that shifting line **868** too far to the left would cause the ECD

to drop below the pore pressure at the casing shoe at depth L1. That is, attempting to provide a maximum pressure reduction at the wellbore bottom, while theoretically increasing the drilling depth, can cause an undesirable under-balance in uphole regions, and in particular, proximate to the casing shoe. Thus, in one arrangement, the pressure differential caused by the APD Device **850** should be selected with reference to the pore pressure at the casing shoe. For example, the pressure differential may be selected such that a safety margin in an overbalance condition is always maintained. In other arrangements, it may be acceptable to select a pressure differential that causes an at-balance or under-balance condition at the casing shoe. In many situations, it may be desirable to utilize the pore pressure at the casing shoe as limit on the pressure differential that can be provided at the wellbore bottom. In any of these control scenarios, the pressure of the wellbore at the casing shoe is either directly or indirectly measured to control whatever condition is selected at the casing shoe **854**.

[0087] It should be understood that the term pressure as it relates to wellbore fluids (e.g., drilling fluids) is used interchangeably with the term equivalent circulating density (ECD) or equivalent static density (ESD). In the above, the term "casing shoe" is used as a reference to the casing shoe proximate to the open hole section of a wellbore.

[0088] As discussed earlier, some of the advantages and benefits of the present invention include the effective management of transient pressure conditions. Generally speaking, drilling operations are dynamic and sometimes unpredictable. Changes in bottomhole pressure or pore pressure, unexpected kicks or losses, and/or changes in mud properties can require

adjustment to the bottomhole pressure control scheme. Accordingly, aspects of the present invention include data communication systems and uplink / downlink devices that provide control over a wellbore pressure management system. Control can be in "real time" at a rate slower than "real time." By "real time", it is meant that the system can react to a detected condition such as pressure transient quickly enough to mitigate that condition. Real time control can also be used to optimize drilling operation by reacting quickly to any conditions that can impair drilling efficiency, ROP, tool life, etc. Thus, to some degree, what represents real time control is a function of the nature, function, and behavior of the device or system being controlled. In the discussion below, data communication systems, including systems utilizing tubulars with signal conductors, are discussed with some selected devices (*i.e.*, an APD Device and sensors). It should be understood, however, that the signal/data communication devices, telemetry systems and related equipment described herein can be utilized to establish data and/or power transmission paths with any of the equipment and devices shown in **Figs. 1-9A,B** and/or previously described.

[0089] Referring now to **Fig. 10**, there is schematically shown one exemplary system **1000** that provides control from the surface to a wellbore pressure management system. The system **1000** includes a surface control unit **1002**, an APD Device **1010**, and one or more sensors **1030**, **1032**. The APD Device **1010** and sensors **1030**, **1032** are positioned along a drill string **1040**, which can include coiled tubing, jointed drill pipe, or other suitable conveyance device. Parameters measured by the sensors **1030**, **1032** include pressure, temperature, flow rate, BHA operating parameters,

formation parameters, drilling parameters and other parameters previously discussed. The sensors **1030**, **1032** can be positioned in modules or subs **1033** that are coupled to the drill string **1040**. Other devices and equipment, of course, will also be present (e.g., **Fig. 1**). However, such devices have already been discussed in detail and, for brevity, their description will not be repeated.

[0090] The control unit **1002** exerts real time control over the APD device **1010** via a data communication system **1050** and, therefore, allows surface personnel to monitor and control the APD device **1010**. The data communication system **1050** uses one or more data transfer/communication links (hereafter "data links") to connect or couple the sensors **1030**, **1032** to the control unit **1002** by establishing one or more signal transmission paths therebetween. Likewise, the data communication system **1050** uses one or more data links to connect or couple the APD Device **1010** to the control unit **1002** by establishing one or more signal transmission paths therebetween. The signal transmission links or paths are used to communicate instructions or command signals from the control unit **1002** to the APD device **1010** and to transmit sensor measurements from the sensors **1030**, **1032** to the control unit **1002**. In certain embodiments, the transmission links or paths are bidirectional and allow two-way communication between the devices connected to the data communication system **1050**.

[0091] In one embodiment, the data links of the data communication system includes devices such as signal/data carriers or conductors **1060** positioned in the wellbore **1004** that couple the APD Device **1010** and sensors **1030**, **1032** to the control unit **1002**. The conductors can include one or more

insulated wires for conveying electrical signals and/or fiber optic wires for conveying optical signals. As shown, the conductors can include conductors **1062** partially or fully embedded in the drill string **1040**, conductors **1064** positioned inside the drill string **1040**, and conductors **1066** positioned on the outside of the drill string **1040**. As is known, drill strings can span hundreds or thousands of meters. Accordingly, the conductors **1060** can include couplings **1068** for joining together individual conductor segments via induction devices, mating conductive rings, transceivers, etc. The couplings **1068** can be integral with pipe joints or be constructed as separate subs or modules. Additionally, subs **1070** positioned along the transmission path can include power packs, processors and other electronics to boost and/or condition the signals being transmitted. For simplicity, the wires, couplings, repeaters, signal boosters and like devices will be collectively referred to as a transmission path or a conductive circuit. One suitable pipe provided with wires includes INTELLIPIPE[®] pipe, a high-speed drill pipe data communication system offered by IntelliServe Inc. Wired drill pipe are discussed in "Very High-Speed Drill String Communications Network" by Novatek, Rocky Mountain E&P Technology Transfer Workshop, August 4, 2003; and "Real real-time drill pipe telemetry: A step-change in drilling", World Oil, October 2003, which are hereby incorporated by reference for all purposes. Additionally, conductors can also be provided in coiled tubing as described in "Development of a Power and Data Transmission Thermoplastic Composite Coiled Tubing for Electric Drilling," SPE Paper 60730, presented in April 2000, which is hereby incorporated by reference for all purposes.

[0092] During operation, parameter measurements, such as pressure measurements, made by the sensors **1030**, **1032** are transmitted via the conductors **1060** to the surface control unit **1002**. The surface control unit **1002** processes the measurements according to preprogrammed instructions. Based on the processed data, surface personnel or the surface control unit **1002** transmit appropriate control signals via the conductors **1060** to the APD Device **1010**. Exemplary control methodologies and devices are shown in **Figs. 7-9A,B** and the accompanying text. Because conductors such as electrical conductors can transmit data at a rate of upwards of one million bits per second, the surface control unit **1002** can adjust operation of the APD Device **1010** soon after the surface control unit **1002** determines that the parameter measurements indicate that such an adjustment is necessary. For example, the control signal can activate an actuator **1012** that controls flow rate through a pump bypass (e.g., bypass **320** (**Figs. 4A-D**)). Additionally, the control unit **1002** can, in real time, evaluate system response to the adjustments based on one or more parameters subsequently measured by the sensor **1030**, **1032** to determine whether further adjustments are necessary. Thus, the data communication system **1050** employing drilling pipe having wires can provide real time control for the system **1000**.

[0093] In another embodiment, two different data communication link can be used in parallel. For example, a data communication system can include a first data link utilizing one or more conductors **1060** positioned in the wellbore **1004** to couple the APD Device **1010** to the control unit **1002** and a secondary data link **1080** such as a mud pulse telemetry devices to couple the sensors **1030**, **1032** to the control unit **1002**. As is known, mud pulse

telemetry is a method of transmitting information through a flowing column of drilling mud using pressure pulses. Typically, pressure in the flowing mud column is modulated by devices such as mud sirens or flow restriction devices and the resulting periodic pressure pulses are detected by a sensor such as a pressure transducer. Such an arrangement may be advantageous, for example, where the APD Device is positioned in an upper section of the wellbore and separated by a considerable distance from the wellbore bottom. By using mud pulse telemetry for the devices such as sensors downhole of the APD Device, only the drill string uphole of the APD Device needs to be fitted with conductors, which may result in cost savings. The selection of a suitable data communication system will depend on the volume of data to be transmitted, the distance over which the telemetry occurs, the required response times, and other known factors. If a particular sensor transmits a low volume of data or if a particular item of equipment can be controlled with limited signal transmission, then a relatively low bandwidth data communication system can be utilized, and vice versa. In a variation not shown, two different data communication systems can be serially arranged. For example, a mud pulse data communication system can be used to transmit data from the sensor **1032** to a downhole receiver (not shown), which then transmits the data via the conductor-based data link **1060** to the surface.

[0094] Referring now to **Fig. 11**, there is shown an exemplary system **1100** for use in closed loop control of an APD device **1110**. The system **1100** includes a downhole control unit **1120**, and one or more sensors **1130**, **1132**. The APD Device **1110** and sensors **1130**, **1132** are positioned along a drill string **1140**, which can include coiled tubing or jointed drill pipe.

Again, other devices and equipment will also be present (e.g., **Fig. 1**) but are not described for the sake of brevity. The control unit **1120** can be programmed in a manner previously described and exert real time control over the APD device **1110** via a data communication system **1150**. The data communication system **1150** utilizing one or more data links **1152**, **1154** establishes signal transmission paths between the control unit **1120** and the sensors **1130**, **1132**. As shown, the control unit **1120** is positioned along or adjacent to the APD device **1110** and, therefore, can utilize a data link suited for short-distance data transmission. In arrangement where the control unit **1120** is positioned uphole or downhole of the APD device **1110**, any of the described data links may be used to establish a transmission path.

[0095] While the data links **1152** and **1154** can be the same, for illustrative purposes, the first data link **1152** is shown utilizing conductors **1156** coupling the sensor **1130** to the control unit **1120** and a second data link **1154** is shown using data transmission stations **1158** to couple the sensor **1132** to the control unit **1120**. Referring now to **Fig. 12**, the data transmission stations **1158** form a network of nodes that relay data uphole and/or downhole. The stations **1158** can be configured to relay signals to an adjacent station **1158** or provide an overreach signal **1159** that can skip one or more adjacent stations **1158**. The overreach signal **1159** can provide redundancy in the network; e.g., allow data transfer even if one station fails. The stations **1158** are distributed along the drill string **1040** can include one or more sensors **1160**, a signal conditioner **1162**, a power source **1164**, a signal booster **1166**, and a transceiver **1168**. The sensors **1160** can measure any of the parameters previously described. The signal conditioner **1162** can be a

processor programmed to process the signal such as by filtering noise, decimating data, etc. The power source **1164** can be a battery source or other device for providing power for the electronics in the data transmission station **1158**. The signal booster **1166** can be used to amplify signals that may weaken during transmission. The transceiver **1168** can be a single device or set of devices that can relay data signals from adjacent data transmission stations **1158**. The transceiver **1168** can utilize a number of transmission media including acoustical signals, radio frequency transmissions, and/or low frequency electromagnetic transmissions to transmit data between stations **1158**. The acoustic signals can be in the form of acoustic stress waves in the drill string **1040** or acoustic signals in the drilling fluid (not shown) in the drill string **1040** that are produced by a suitable source (e.g., a piezoelectric stack). Suitable data transmission stations are described in commonly assigned U.S. Patent Application Serial No. **10/867,304**, filed June 14, 2004, which is hereby incorporated by reference for all purposes. Additionally, U.S. Pat. No. 5,160,925, which is incorporated herein by reference for all purposes, discloses a modular communication link placed in the drill string for receiving data from the various sensors and devices and transmitting such data upstream or downstream.

[0096] Referring now to **Fig. 11**, during operation, parameter measurements made by the sensors **1130**, **1132** are transmitted via the conductors **1156** and data transmission stations **1158**, respectively, to the control unit **1120**. The control unit **1120** processes the measurements and, if needed, transmits appropriate control signals to the APD Device **1110**. Because of the relatively large volume of data that can be transmitted by the

data links **1152** and **1154**, the downhole control unit **1120** can adjust operation of the APD Device **1110** almost immediately after the downhole control unit **1120** determines that the parameter measurements indicate that such an adjustment is necessary. The downhole control unit **1120** can control the APD Device **1110** in an autonomous closed loop fashion or prompt surface personnel for a suitable response.

[0097] It should be understood that the **Fig. 10** and **Fig. 11** embodiments are complementary and are not exhaustive. For example, an exemplary control system can utilize a surface control unit that cooperates with a downhole control unit. Also, the control system, whether downhole or at the surface, need not control the APD device in response to any particular sensor measurement. For example, the control system can merely operate the APD Device according to one or more preset operating norms. Also, the sensors need not be fixed to the drill string. For example, a sensor can be positioned at the last casing shoe. Further, the data communication systems (e.g., acoustic, RF, EM, mud pulse) discussed in reference to **Figs. 10** and **11** are interchangeable and not limited to the embodiment in which they are described. It should also be understood that the devices described in connection with **Figs. 10** and **11** (e.g., the APD Device, control units, sensors, etc.) have been discussed in detail previously and features, operations, functions of these devices are best understood in reference to **Figs. 1-9A,B** and associated text. Also, it is again emphasized that the described data communication systems can be applied to uses other than controlling the APD Device. For example, the data communication system can be used to transmit formation evaluation data and dynamic drilling data from downhole

sensors to the surface. Additionally, control signals can be sent via the data communication system to downhole devices such as steering units, the drilling motor, the annular seal, valve actuators, etc.

[0098] While the conductors have been described as suited for carrying data signals, it should be understood in certain arrangements that the conductors can be used to transmit electrical power to one or more downhole devices. Moreover, depending on the particular application, the data links can be unidirectional or bi-directional. Also, the terms "signal" and "data" have been used interchangeably above.

[0099] In other embodiments, the APD Device can be used outside of the drilling context to provide wellbore pressure management during activities such as completion and workover. For instance, in one application, the APD Device can be used to control pressure in a wellbore when deploying wellbore tools and equipment. Exemplary deployments include running, installing, and/or operating wellbore equipment in the wellbore. Exemplary wellbore tools and equipment includes liners, packers, screens, liner hangers, anchors, completion equipment, fishing tools, perforating tools, whipstocks, and other tools and devices adapted to perform a selected task in a wellbore. In an exemplary application, fluid may be circulated in the wellbore while running the wellbore equipment in the wellbore. The APD Device can be set to reduce a dynamic pressure loss associated with the circulating fluid. For instance, while running liner, the APD Device can be positioned adjacent a liner hanger coupled to the liner. The pressure control provided by the APD Device can be configured to maintain wellbore pressure below a fracture pressure of a formation while running the liner. Moreover, in some

embodiments, the APD Device can be configured to reduce a surge effect associated with the running of the selected wellbore equipment.

[00100] Furthermore, in addition to drilling fluids, the APD Device can be used to control pressure in a wellbore when circulating other fluids such as slurries used to gravel pack a formation, completion fluids, cement, acids, and workover fluids ("non-drilling fluids"). In certain applications, the total pressure applied by circulation of the non-drilling fluids can exceed the fracture pressure of a given formation. Advantageously, the APD Device can reduce the dynamic pressure loss component of this pressure and thereby assist in maintaining the total pressure below the formation fracture pressure.

[00101] While the foregoing disclosure is directed to the preferred embodiments of the invention, various modifications will be apparent to those skilled in the art. It is intended that all variations within the scope of the appended claims be embraced by the foregoing disclosure.

WHAT IS CLAIMED IS:

1. An apparatus for controlling pressure in a wellbore drilled in a formation using a drill string and wherein a drilling fluid supplied under pressure to the drill string returns to the surface ("the return fluid"), the system comprising:
 - (a) an Active Pressure Differential Device ("APD Device") in the return fluid to control wellbore pressure; and
 - (b) a data link coupled to the APD Device.

2. The apparatus according to claim 1 wherein the data link transmits data between the APD Device and one of (i) a controller, (ii) a processor, (iii) a surface display, (iv) a data storage device, (v) a transmitter, and (vi) a receiver.

3. The apparatus according to claim 1 wherein the data link includes one of (i) an electrical conductor; (ii) a fiber optic wire, (iii) a fluid column, and (iv) an acoustic wave path.

4. The apparatus according to claim 1 wherein the data link uses a transmission media selected from one of (i) acoustic, (ii) electrical, (iii) electromagnetic, (iv) mud pulse; (v) optical, (vi) flow variation, and (vii) pressure variation.

5. The apparatus according to claim 1 further comprising a controller controlling the APD Device.
6. The apparatus according to claim 5 further comprising at least one sensor in the wellbore measuring a selected parameter of interest and coupled to the data link, the APD Device being controlled in response to measurements made by the at least one sensor.
7. The apparatus according to claim 1 wherein the data link comprises an electrical conductor positioned at one of: (i) at least partially along the drill string, (ii) integral with the drill string, (iii) inside the drill string, and (iv) one or more joints in the drill string.
8. The apparatus according to claim 1 wherein the data link includes a plurality of stations, each station adapted to relay signals from an adjacent station.
9. The apparatus according to claim 1 wherein the data link transmits data between at least one of (i) the APD Device and a controller controlling the APD Device, (ii) at least one sensor and a controller controlling the APD Device, and (iii) the APD Device and at least one sensor.
10. The apparatus according to claim 1 wherein the data link comprises a first link at least partially formed of a conductor and a second link that uses mud pulse signals.

11. A method for controlling pressure in a wellbore drilled in a formation using a drill string having a bottomhole assembly at an end thereof and wherein a drilling fluid supplied under pressure to the drill string returns to the surface ("the return fluid"), the method comprising:

- (a) controlling wellbore pressure with an Active Pressure Differential Device ("APD Device") positioned in the return fluid; and
- (b) coupling a data link to the APD Device.

12. The method of claim 11 further comprising coupling the data link to one of (i) a controller, (ii) a processor, (iii) a surface display, (iv) a data storage device, (v) a transmitter, and (iv) a receiver.

13. The method according to claim 11 wherein the data link includes one of (i) an electrical conductor; (ii) a fiber optic wire, (iii) a fluid column, and (iv) an acoustic wave path.

14. The method according to claim 11 wherein the transmitting step uses one of (i) acoustics, (ii) electrical signals, (iii) electromagnetics, (iv) mud pulse; (v) optical signals, (vi) flow variation, and (vii) pressure variation.

15. The method according to claim 11 further comprising controlling the APD Device with a controller.

16. The method according to claim 15 further comprising controlling the APD Device in response to measurement made by at least one sensor in the wellbore.

17. The method according to claim 11 further comprising forming the data link with an electrical conductor positioned at one of: (i) at least partially along the drill string, (ii) integral with the drill string, (iii) inside the drill string, and (iv) one or more joints in the drill string.

18. The method according to claim 11 further comprising forming the data link using a plurality of stations, each station adapted to relay signals from an adjacent station.

19. The method according to claim 11 further comprising transmitting data using the data link between at least one of (i) the APD Device and a controller controlling the APD Device, (ii) at least one sensor and a controller controlling the APD Device, and (iii) the APD Device and at least one sensor.

20. The method according to claim 19 further comprising transmitting data across the data link using at least a conductor and mud pulse signals.

21. A system for controlling pressure in a wellbore in a formation, the system comprising:

- (a) a platform positioned at a surface location;
- (b) a drill string conveyed into the wellbore from the platform;
- (c) a drilling fluid source supplying drilling fluid to the drill string, the drilling fluid returning to the surface ("the return fluid")
- (d) an Active Pressure Differential Device ("APD Device") in the return fluid to control wellbore pressure; and
- (e) a data link coupled to the APD Device.

22. The system according to claim 21 wherein the data link transmits data between the APD Device and one of (i) a controller, (ii) a processor, (iii) a surface display, (iv) a data storage device, (v) a transmitter, and (iv) a receiver.

23. The system according to claim 21 wherein the data link includes one of (i) an electrical conductor; (ii) a fiber optic wire, (iii) a fluid column, and (iv) an acoustic wave path.

24. The system according to claim 21 wherein the data link uses a transmission media selected from one of (i) acoustic, (ii) electrical, (iii) electromagnetic, (iv) mud pulse; (v) optical, (vi) flow variation, and (vii) pressure variation.

25. The system according to claim 21 further comprising: a controller controlling the APD Device.

26. The system according to claim 25 comprising at least one sensor in the wellbore measuring a selected parameter of interest and coupled to the data link, the APD Device being controlled in response to measurements made by the at least one sensor.
27. The system according to claim 21 wherein the data link comprises an electrical conductor positioned at one of: (i) at least partially along the drill string, (ii) integral with the drill string, (iii) inside the drill string, and (iv) one or more joints in the drill string.
28. The system according to claim 21 further comprising a controller controlling the APD Device.
29. The system according to claim 21 wherein the data link includes a plurality of stations, each station adapted to relay signals from an adjacent station.
30. The system according to claim 21 wherein the data link transmits data between at least one of (i) the APD Device and a controller controlling the APD Device, (ii) at least one sensor and a controller controlling the APD Device, and (iii) the APD Device and at least one sensor.
31. The system according to claim 21 wherein the data link comprises a first link at least partially formed of a conductor and a second link that uses mud pulse signals.

1/14

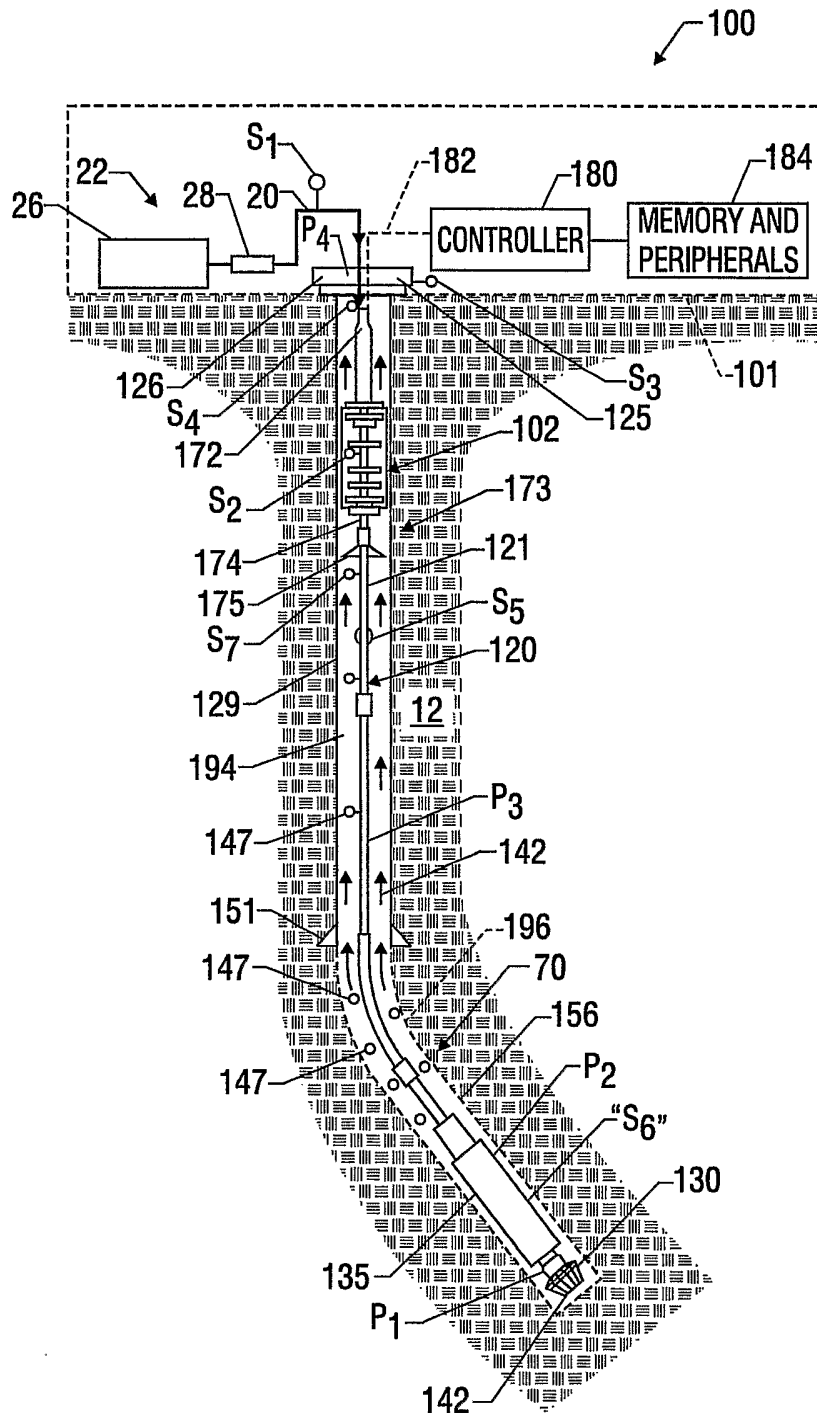

FIG. 1A

2/14

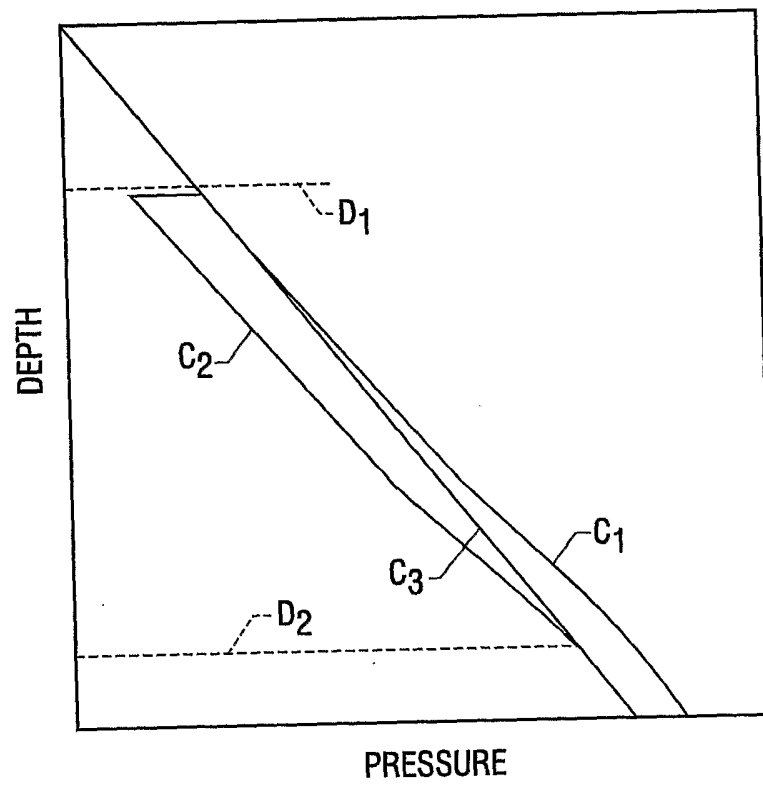

FIG. 1B

3/14

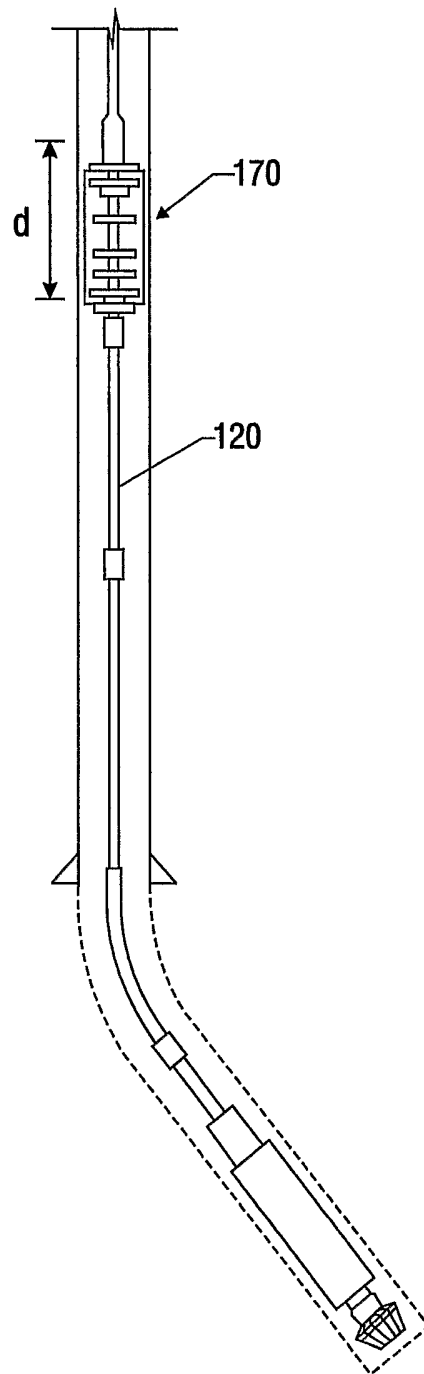

FIG. 2

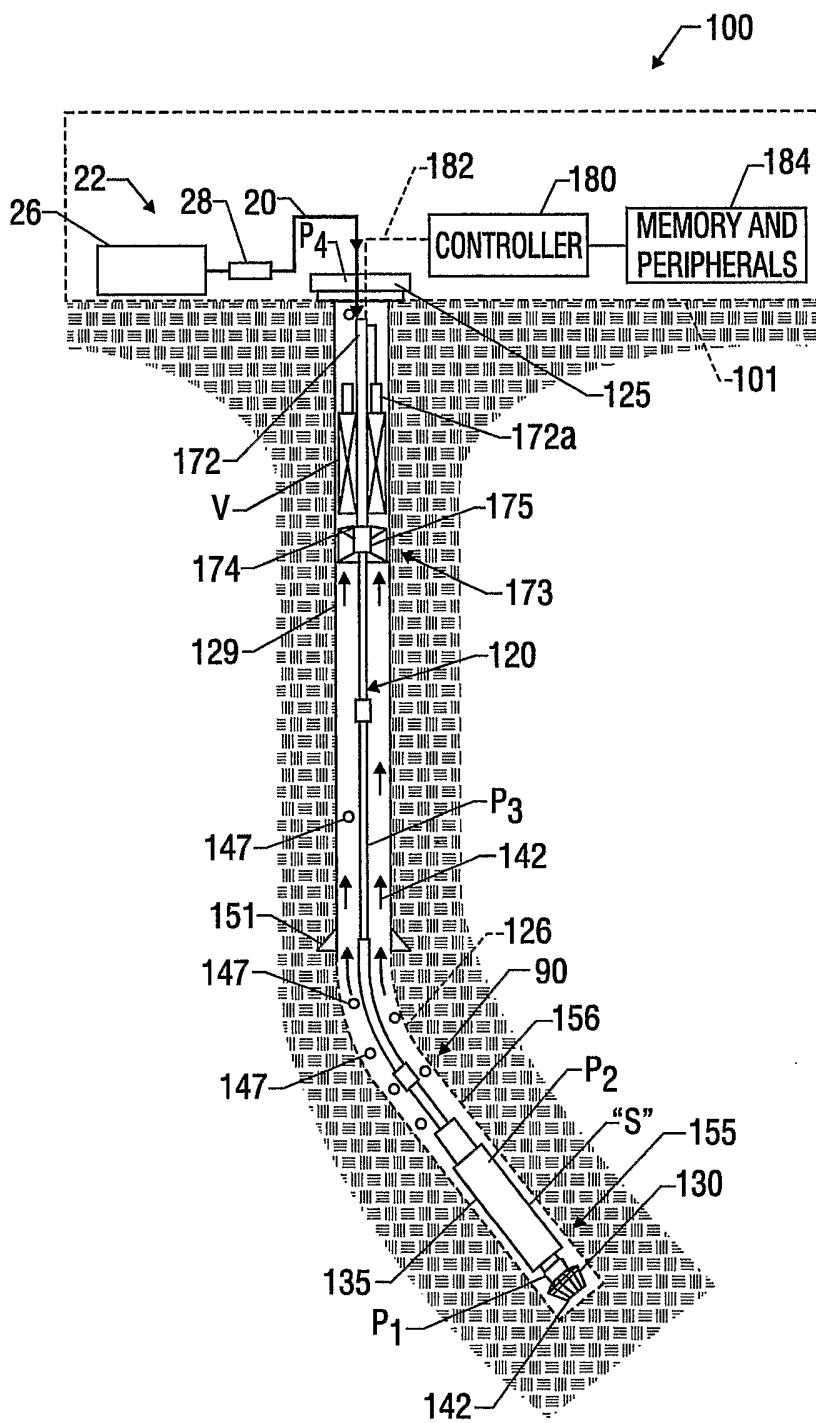

FIG. 3

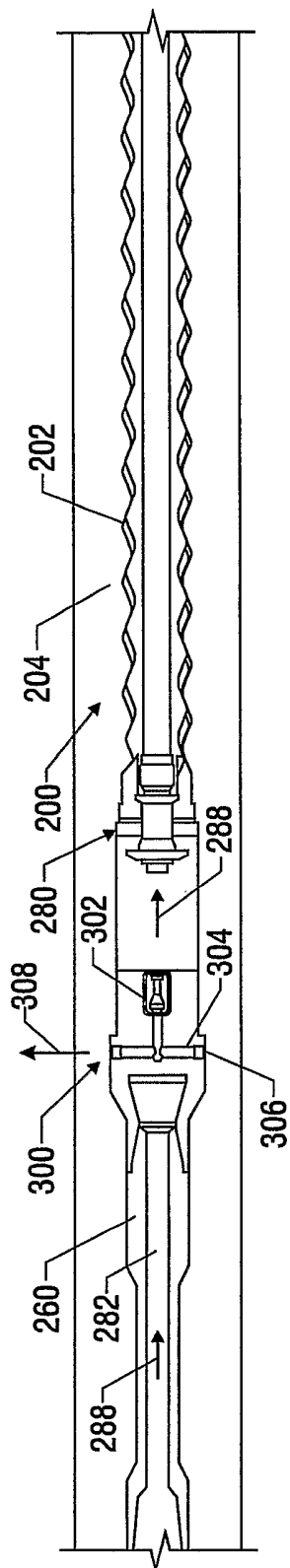

FIG. 4A

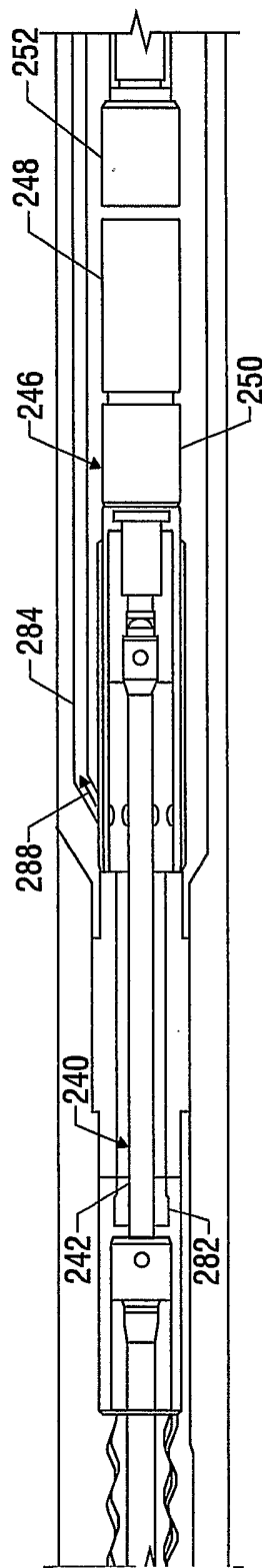

FIG. 4B

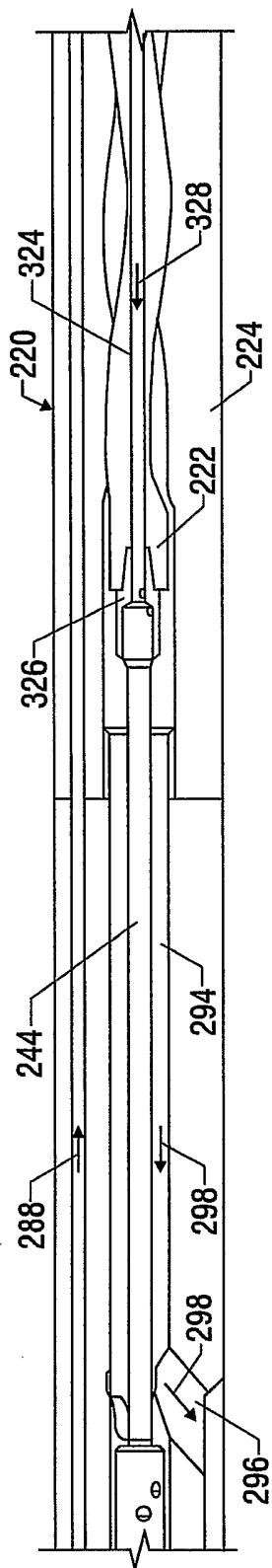

FIG. 4C

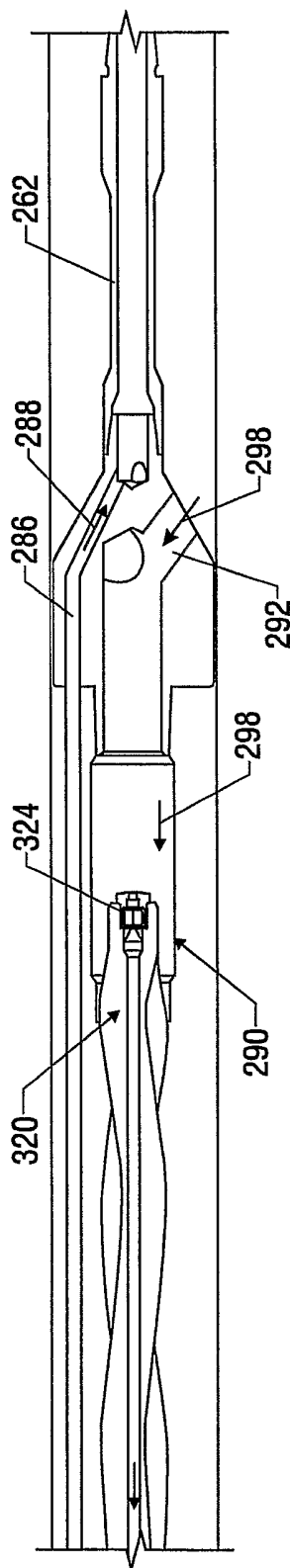

FIG. 4D

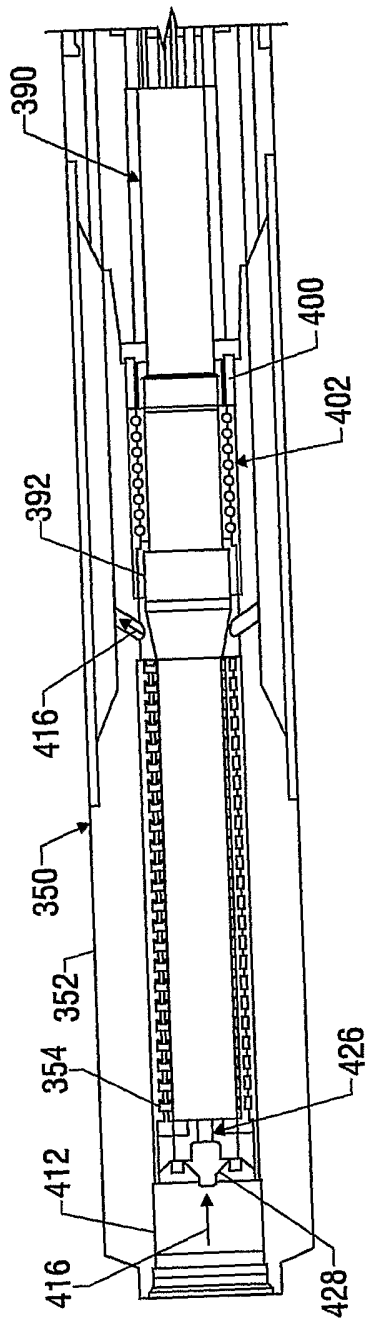

FIG. 5A

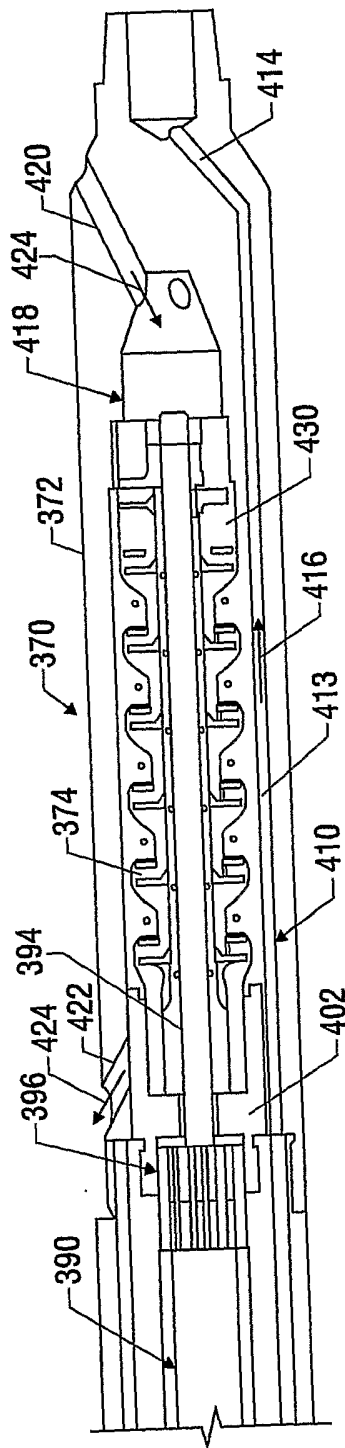

FIG. 5B

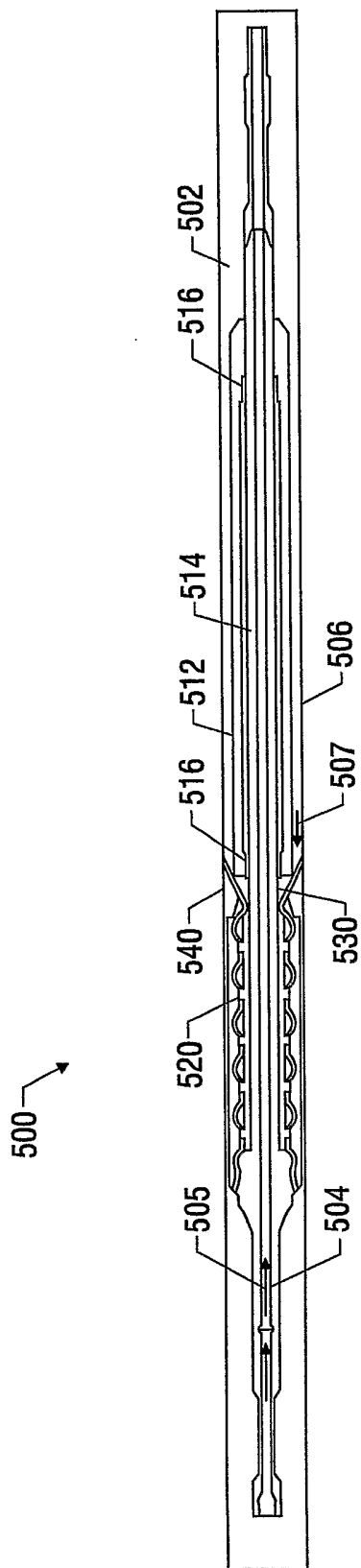

FIG. 6A

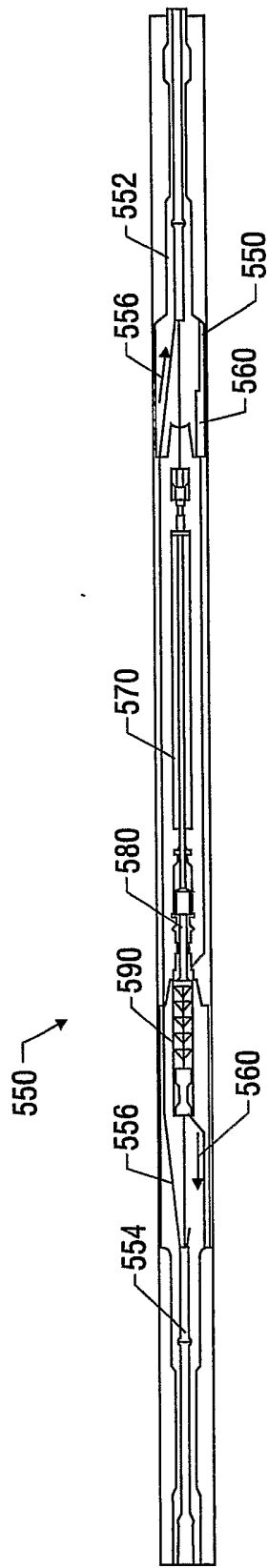

FIG. 6B

9/14

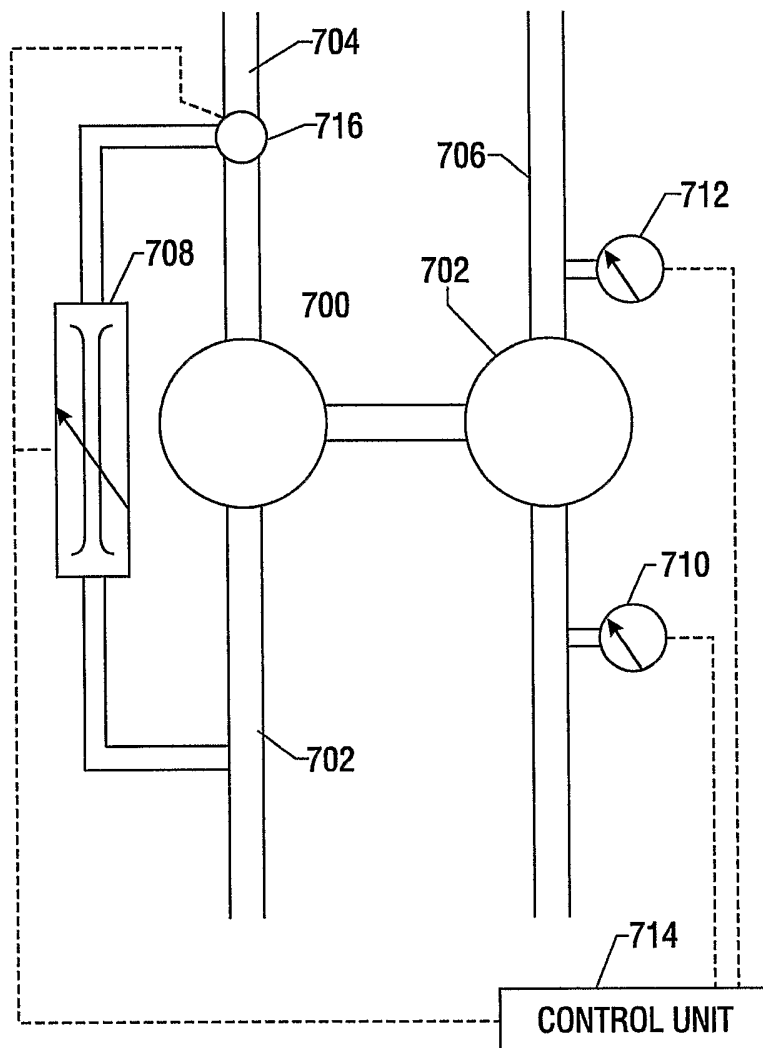

FIG. 7

10/14

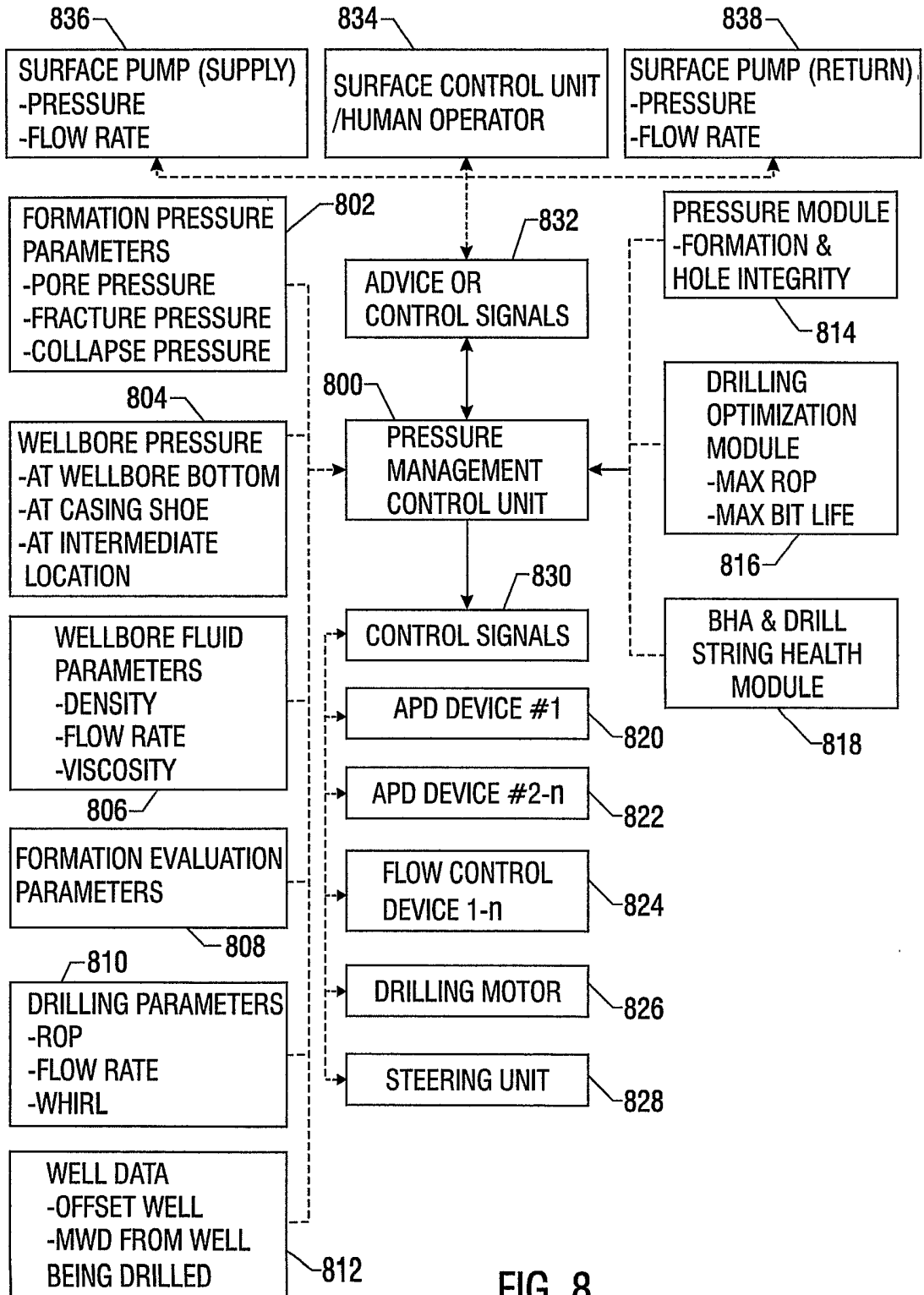

FIG. 8

11/14

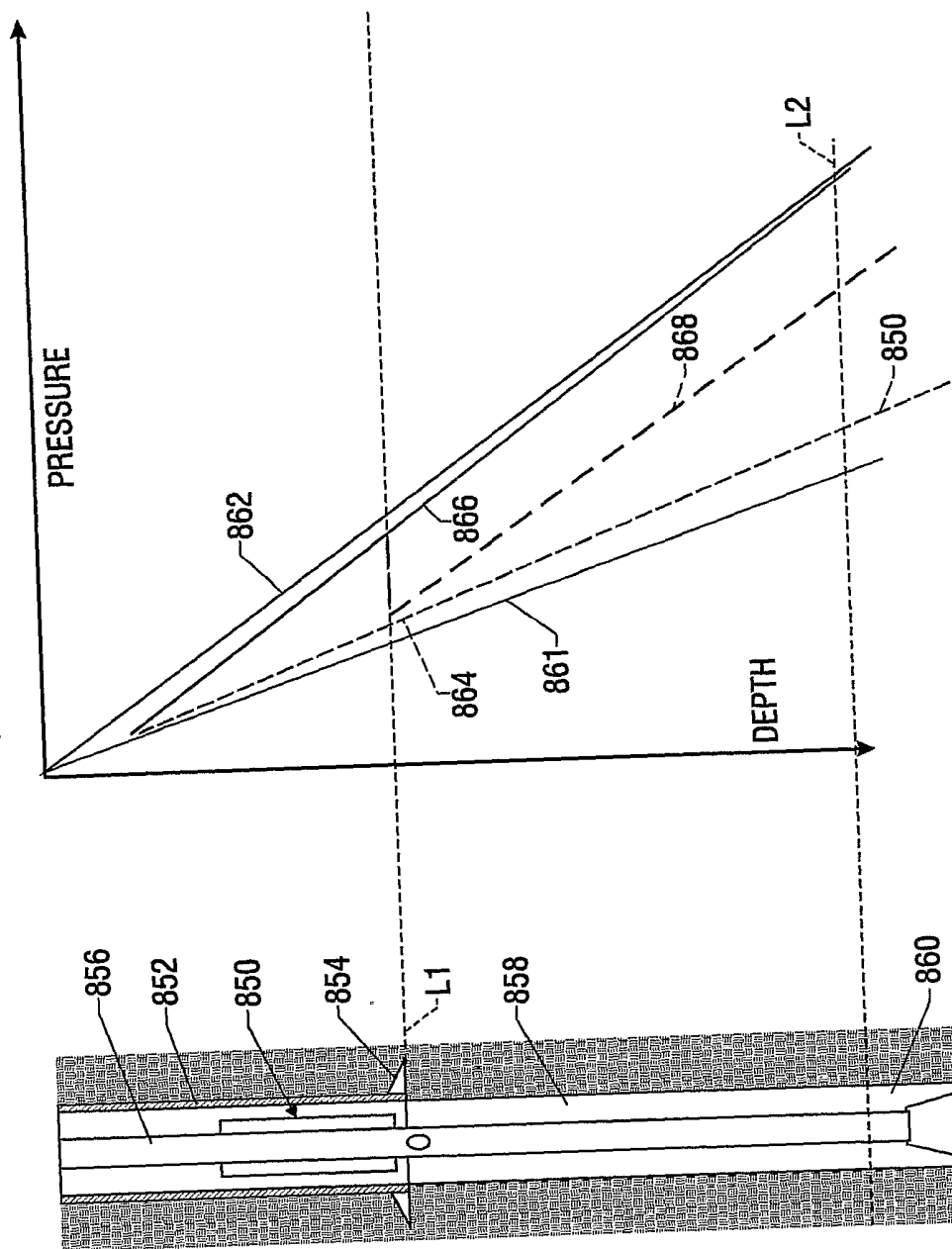

FIG. 9B

FIG. 9A

12/14

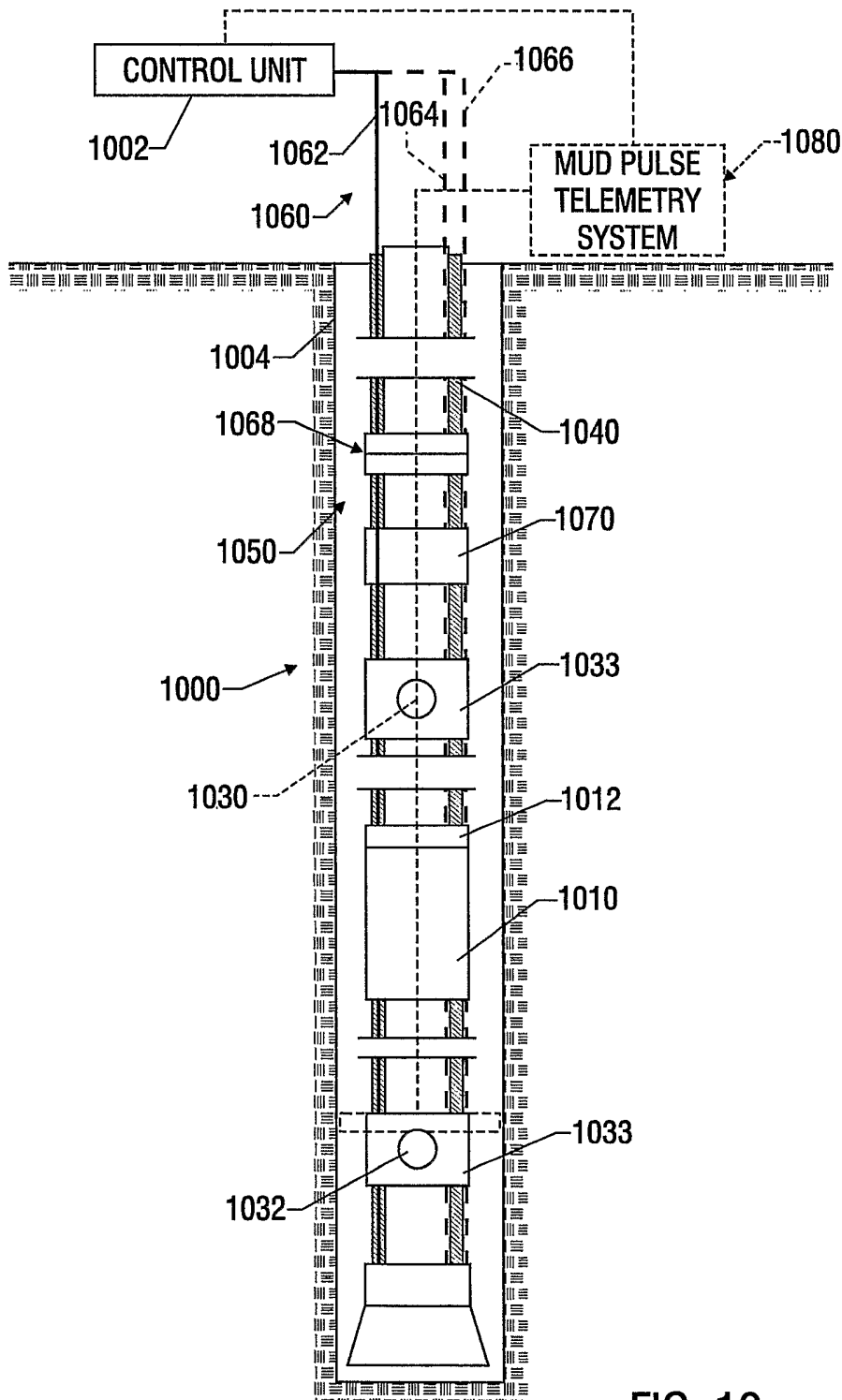

FIG. 10

13/14

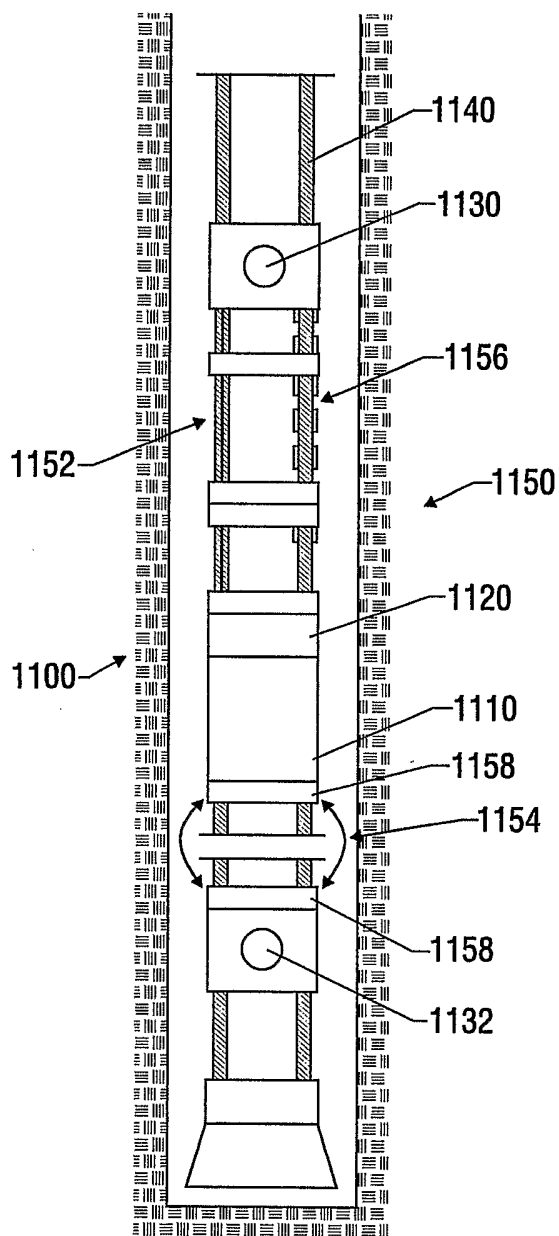

FIG. 11

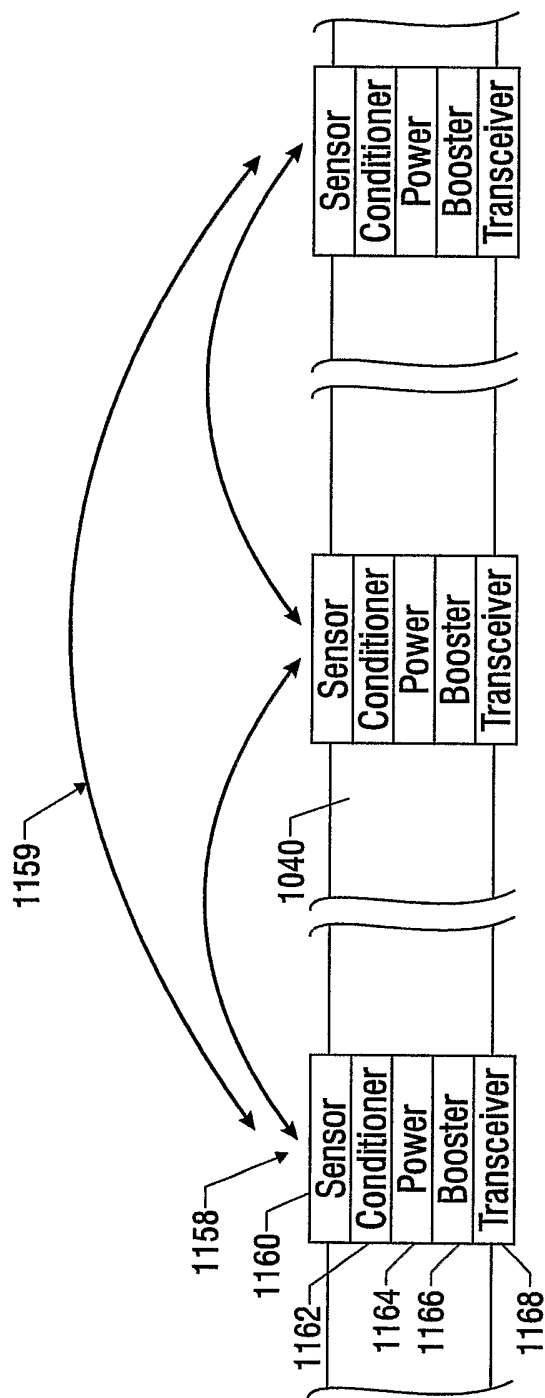

FIG. 12

INTERNATIONAL SEARCH REPORT

International application No
PCT/US2006/009013

A. CLASSIFICATION OF SUBJECT MATTER
INV. E21B21/08

According to International Patent Classification (IPC) or to both national classification and IPC

B. FIELDS SEARCHED

Minimum documentation searched (classification system followed by classification symbols)
E21B

Documentation searched other than minimum documentation to the extent that such documents are included in the fields searched

Electronic data base consulted during the international search (name of data base and, where practical, search terms used)

EPO-Internal, WPI Data

C. DOCUMENTS CONSIDERED TO BE RELEVANT

Category*	Citation of document, with indication, where appropriate, of the relevant passages	Relevant to claim No.
X	US 2004/069504 A1 (KRUEGER VOLKER ET AL) 15 April 2004 (2004-04-15) sentences 11-13, paragraph 37 paragraphs [0044], [0046], [0049] - [0052] figure 1 <p style="text-align: center;">-----</p>	1-31

Further documents are listed in the continuation of Box C.

See patent family annex.

* Special categories of cited documents :

- "A" document defining the general state of the art which is not considered to be of particular relevance
- "E" earlier document but published on or after the international filing date
- "L" document which may throw doubts on priority claim(s) or which is cited to establish the publication date of another citation or other special reason (as specified)
- "O" document referring to an oral disclosure, use, exhibition or other means
- "P" document published prior to the international filing date but later than the priority date claimed

- "T" later document published after the international filing date or priority date and not in conflict with the application but cited to understand the principle or theory underlying the invention
- "X" document of particular relevance; the claimed invention cannot be considered novel or cannot be considered to involve an inventive step when the document is taken alone
- "Y" document of particular relevance; the claimed invention cannot be considered to involve an inventive step when the document is combined with one or more other such documents, such combination being obvious to a person skilled in the art.
- "&" document member of the same patent family

Date of the actual completion of the international search

6 June 2006

Date of mailing of the international search report

13/06/2006

Name and mailing address of the ISA/
 European Patent Office, P.B. 5818 Patentlaan 2
 NL - 2280 HV Rijswijk
 Tel. (+31-70) 340-2040, Tx. 31 651 epo nl,
 Fax: (+31-70) 340-3016

Authorized officer

Schouten, A

INTERNATIONAL SEARCH REPORT

Information on patent family members

International application No

PCT/US2006/009013

Patent document cited in search report	Publication date	Patent family member(s)	Publication date
US 2004069504	A1	NONE	