



US 20050031489A1

(19) **United States**

(12) **Patent Application Publication**
Angros

(10) **Pub. No.: US 2005/0031489 A1**

(43) **Pub. Date: Feb. 10, 2005**

(54) **ANALYTIC PLATE WITH CONTAINMENT BORDER**

is a division of application No. 09/021,077, filed on Feb. 10, 1998, now Pat. No. 5,948,685.

(76) Inventor: **Lee H. Angros**, Bethany, OK (US)

Publication Classification

Correspondence Address:
DUNLAP, CODDING & ROGERS P.C.
PO BOX 16370
OKLAHOMA CITY, OK 73113 (US)

(51) **Int. Cl.⁷** **G01N 21/00**
(52) **U.S. Cl.** **422/57**

(21) Appl. No.: **10/944,522**

(57) **ABSTRACT**

(22) Filed: **Sep. 17, 2004**

Related U.S. Application Data

(60) Continuation of application No. 10/123,800, filed on Apr. 15, 2002, now Pat. No. 6,818,451, which is a continuation-in-part of application No. 09/370,512, filed on Aug. 6, 1999, now Pat. No. 6,372,507, which

An analytic plate such as a microscope slide or a diagnostic plate and kit having the slide or plate, the slide or plate having a containment border for containing a liquid or liquid sample. The containment border is substantially transparent and/or invisible and has a thickness of a substantially molecular layer. The containment border contains the liquid or liquid sample disposed thereon thereby preventing spreading or migration of the sample across the slide or plate.

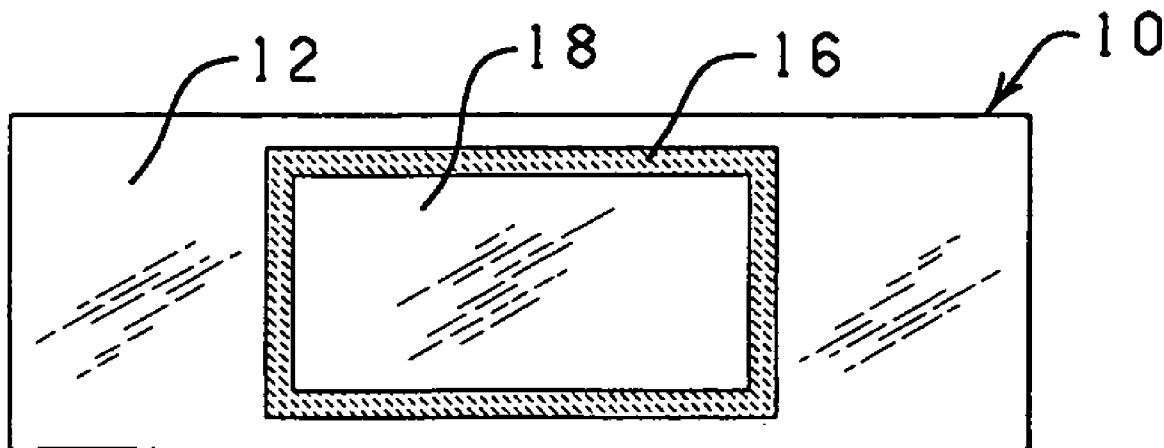

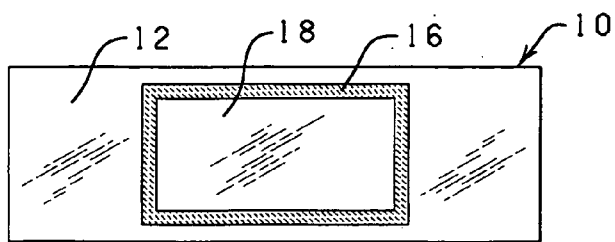

FIG. 1A

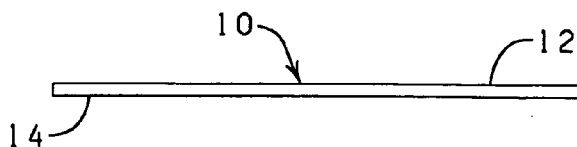

FIG. 1B

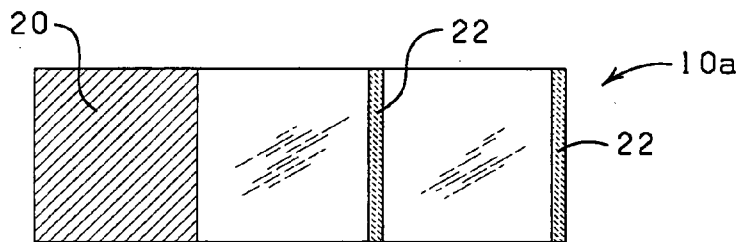

FIG. 2A

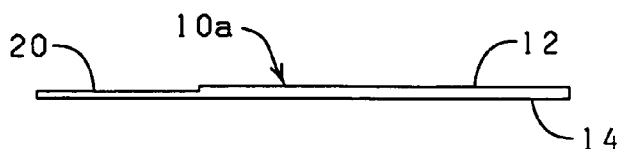

FIG. 2B

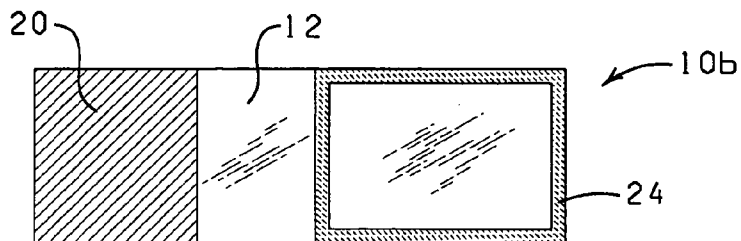
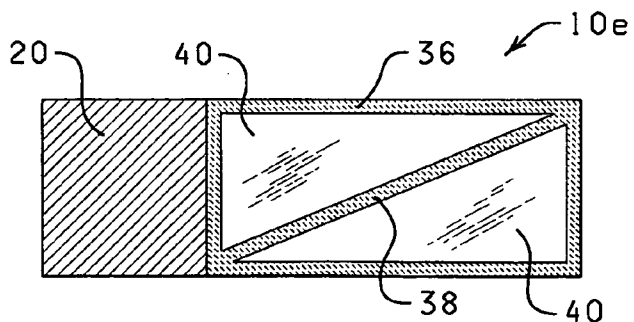
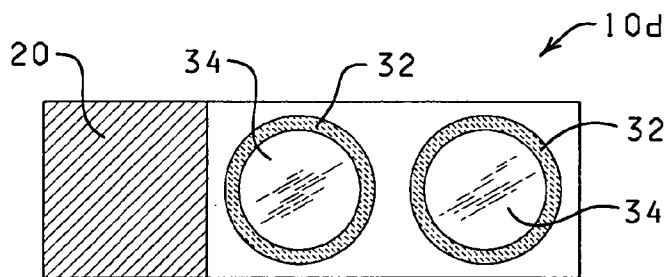
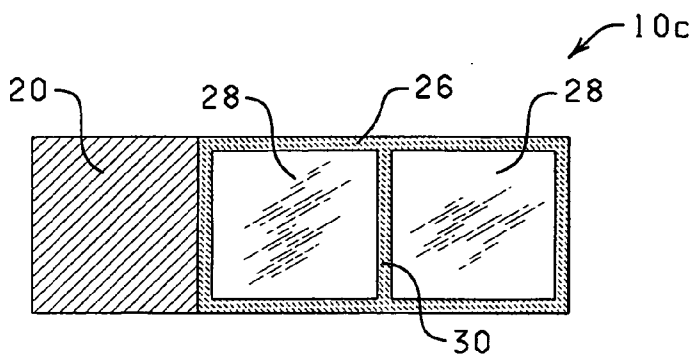

FIG. 3



ANALYTIC PLATE WITH CONTAINMENT BORDER

CROSS-REFERENCE TO RELATED APPLICATIONS

[0001] The present application is a continuation of U.S. Ser. No. 10/123,800, filed Apr. 15, 2002, which is a continuation-in-part of U.S. Ser. No. 09/370,512, filed Aug. 6, 1999, now U.S. Pat. No. 6,372,507, which is a divisional of U.S. Ser. No. 09/021,077, filed Feb. 10, 1998, now U.S. Pat. No. 5,948,685. The specification of each of the above-referenced patents or patent applications is hereby explicitly incorporated herein by reference in its entirety.

STATEMENT REGARDING FEDERALLY SPONSORED RESEARCH OR DEVELOPMENT

[0002] Not Applicable

BACKGROUND

[0003] The present invention relates generally to the field of analytic plates such as microscope slides or diagnostic plates and more particularly to such analytic plates having borders thereon.

[0004] Standard microscope slides and diagnostic glass plates are thin rectangular sheets of glass or plastic. In use, a sample comprising an aqueous or non-aqueous liquid, liquid reagent, biological fluid and/or biological tissue section(s) is placed upon a portion of the slide or diagnostic glass plate. Before analysis, the sample on the slide or plate may be dried, placed in a fixative, or remain fresh prior to treatment for enhanced visualization by light, electron, or fluorescent microscopy, and/or including gross analysis with the human eye. The sample may be analyzed in its natural state or may need treatment with one or more liquid dyes to enhance visualization. Further treatment with molecular biological techniques may include, for example, treatment by monoclonal, polyclonal antibodies, in-situ hybridization by molecular probes, and/or their liquid detection reagents. During routine analysis or manipulation of a slide or plate, the sample or liquid reagent may spill from the slide, run or migrate onto other portions of the slide, and/or "wick off" if the slide touches another object, thus resulting in a loss of all or part of the liquid sample or reagent. It is desirable to avoid such inadvertent or undesired mixing or contamination of different samples or liquid reagents.

[0005] It is therefore beneficial for the slide to have means to confine the sample or liquid used in treating the sample to a specific area on the slide or plate. This has been accomplished previously by creating a slide or plate having one or more depressions, or "wells" therein. Alternatively, a physical barrier or hydrophobic material may be applied to the slide surface in a bordered pattern to confine the liquid applied to the plate within the area surrounded by the border. Such borders may comprise a coating of teflon, paint, wax, paraffin, epoxy resin, or other resinous material, or a paint. Each of these materials results in a border having a thickness resulting in a raised border extending a distance above the surface of the glass, for example, a teflon layer may be about 0.0025 inches high. These raised areas are generally opaque and the end result is a loss of the transparent nature of the slide. In spite of the fact that these raised borders may be somewhat effective in confining the liquid, there continues

to be a need for a slide or plate which achieves confinement of the liquid upon a slide while maintaining transparency of the glass or plate. It is the object of the present invention to provide such a slide.

SUMMARY OF THE INVENTION

[0006] The present invention contemplates an analytic plate such as a microscope slide or a diagnostic plate having a containment border for inhibiting migration of liquids or liquid samples thereon, wherein the border is substantially transparent and is substantially flush with the surface of the slide or plate and which covers only a portion of the surface of the slide or plate.

BRIEF DESCRIPTION OF THE DRAWINGS

[0007] FIG. 1A is a plan view of a microscope slide constructed in accordance with the present invention.

[0008] FIG. 1B is a side view of the slide of FIG. 1A.

[0009] FIG. 2A is a plan view of another version of a microscope slide constructed in accordance with the present invention.

[0010] FIG. 2B is a side view of the slide of FIG. 2A.

[0011] FIG. 3 is a plan view of another version of a microscope slide constructed in accordance with the present invention.

[0012] FIG. 4 is a plan view of another version of a microscope slide constructed in accordance with the present invention.

[0013] FIG. 5 is a plan view of another version of a microscope slide constructed in accordance with the present invention.

[0014] FIG. 6 is a plan view of another version of a microscope slide constructed in accordance with the present invention.

DETAILED DESCRIPTION OF THE INVENTION

[0015] The present invention contemplates an analytic plate such as a microscope slide or a diagnostic plate having a containment border for inhibiting migration of liquids or liquid samples thereon, wherein the border is substantially transparent and is substantially flush with the surface of the slide or plate and which covers only a portion of the surface of the slide or plate.

[0016] Where used herein, the term "analytic plate" refers to those types of plates such as microscope slides and diagnostic plates which are used, for example, in microscopic analysis or diagnostic analysis or comparison of samples. Analytic plates are generally comprised of clear glass or plastic but may also comprise ceramic materials.

[0017] Referring now to FIGS. 1A and 1B, a glass microscope slide having the general reference numeral 10 is shown. The slide 10 has a conventional length, width and thickness as is well known to one of ordinary skill in the art. The slide 10 has an upper surface 12 and a lower surface 14. Disposed upon a portion of the upper surface 12 is a containment border 16 for containing a liquid and which in the version of FIG. 1A has a rectangular shape. Where used

herein the term "containment border" refers to a transparent border which prevents or inhibits passage of an aqueous or non-aqueous liquid thereacross. The containment border **16** surrounds a containment area **18** of the upper surface **12** of the slide **10**. The containment border **16** forms a liquid barrier about the containment area **18**. When a liquid or liquid sample (not shown) is placed upon the containment area **18** of the slide **10** for analysis, the containment border **16** prevents or inhibits the spreading, leakage or migration of the liquid or liquid sample from the containment area **18**, thus causing the sample to be retained in a discrete and confined location upon the slide **10**. Where used herein, the term liquid or liquid sample is intended to refer to a liquid material, or a liquid biological sample (e.g., blood, urine, plasma, or cerebrospinal fluid) which is desired to be localized on the slide.

[0018] The coating material which is used to form the containment border **16** comprises a material, as defined below, which when applied to the slide **10** is preferably transparent although it may have a color to indicate its position on the slide or have printed, by one of ordinary skill in the art, on the lower surface **14** and/or upper surface **12** of the slide **10** information (lines or numbers or symbols) indicating the position of the containment border **16** on the upper surface **12**. The containment border **16** forms a molecular layer when dry and therefore is substantially flush (level) with the upper surface **12** of the slide **10**. The containment border **16** is therefore not raised above the upper surface **12** to a degree that is visible to the naked eye. In fact, the containment border **16** typically has a thickness of less than 0.0001 inch and more generally less than 0.00001 inch.

[0019] In a preferred embodiment the coating material which forms the containment border **16** is a composition comprising a liquid repellent compound dissolved in a volatile solvent. In a particularly preferred version, the composition comprises an alkyl polysiloxane and a mineral acid mixed with a solvent such as described in U.S. Pat. No. 3,579,540, the specification of which is hereby incorporated herein by reference in its entirety. Other polysiloxanes, siloxanes, silicones and silicon fluids or combinations thereof which can permanently or at least temporarily bond to a glass surface and function in accordance with the present invention are also contemplated and are known, and available commercially for use herein as coating materials. Although a polysiloxane acid mixture is particularly preferred, it will be understood by one of ordinary skill in the art that any coating material which can adhere to the surface of a glass slide or plate and which forms a substantially non-raised molecular layer as described above is suitable for use in the present invention.

[0020] The coating material can be applied to the slide **10** in any manner known in the art, for example, by brushing, by using a stamping device or by spraying or by application from a device such as a pen and having a ball-tip or brush-tip applicator and which is filled with the coating material to be applied to the slides or plates.

[0021] In an alternative method of application of the coating material for the containment border **16**, the analytic slide may be provided with a removable raised layer of a material such as a silicone rubber which is applied as a raised strip on a portion of the upper surface **12** of the slide

10 (not shown). Prior to the application of the liquid or liquid sample for treatment, the raised silicone strip is peeled away from the upper surface **12** of the slide **10**, leaving a residual coating comprising a containment border **16** in accordance with the present invention. After the raised silicone rubber strip has been peeled away leaving the containment border **16** as defined elsewhere herein, the analytic plate can be used in accordance with the present invention.

[0022] It is another distinctive characteristic of the present invention that after the coating material is applied to the slide **10** to form the containment border **16** and the coating material has dried thereon, the containment border **16** is highly resistant to removal by chemical removal or physical removal, for example by washing, scrubbing, soaking in acids, alkalis, organic solvents, and aqueous solvents. The slide **10** can therefore be used repeatedly without losing its functionality.

[0023] The containment border **16** of the present slide **10** is further distinguished from prior art slides with borders which have teflon borders or other physical barriers because the surface of such prior art slides must be treated before the teflon coating can adhere to the slide (e.g., using an adhesive) thus causing solvents to dissolve the adhesive and the subsequent loss of the borders efficiency due to peeling and/or loss of the liquid confinement integrity of the border. The borders of slides using coatings of teflon, epoxy, or paint are generally opaque and are raised above the surface of the slide, unlike the borders on the slides of the present invention. In the present invention, there is no intervening layer (e.g., an adhesive) between the glass and the coating material comprising the containment border **16**.

[0024] Although the microscope slide of the present invention may consist solely of a slide **10** with the containment border **16** thereon, in some embodiments the slide may further have a distinct marking surface thereon for writing upon or for attaching a label thereto. FIGS. 2A and 2B show such a slide, designated therein by the general reference numeral **10a**. The slide **10a** has a marking surface **20** which is a "frosted" portion of the slide **10a** (i.e., a portion of the slide **10a** which has been etched off or abraded). In an alternative version of such a slide, the marking surface **20** may be an opaque epoxy or painted coating. Other means of forming a marking surface will be apparent to one of ordinary skill in the art. FIG. 2A further shows an alternative version of the invention wherein the containment border, designated by the general reference numeral **22** comprises a pair of strips extending from one edge of the slide to another, rather than forming a box pattern, as shown in slide **10a**. FIG. 3 shows a slide **10b** which is essentially the same as slide **10a** except the containment border is a border **24** which forms an entire "box" on the surface **12** of the slide **10b**. FIG. 4 shows an alternative embodiment of the invention, a slide **10c** having a containment border **26** which comprises a pair of separate containment areas **28**. The separate containment areas **28** can therefore contain separate samples which are prevented from mixing by the portion **30** of the containment border **26** which separates the two containment areas **28**. Although not specifically shown in the figure, the slide **10c** may be constructed to comprise a plurality of separate containment areas **28** greater than two for holding a plurality of samples, as will be understood by a person of ordinary skill in the art. FIG. 5 shows a slide **10d** having a pair of circular containment borders **32** which

surround containment areas **34**. Alternative versions of slide **10d** may have only a single circular containment border **32**, or may have a plurality of circular containment borders **32**. **FIG. 6** shows a slide **10e** comprising a containment border **36** having a diagonal border **38** extending thereacross forming a pair of triangle shaped containment areas **40**. Alternative versions of the slide **10e** may have only a single triangle shaped containment area **40**, or may have a plurality of areas **40**. Further, it will be understood by a person of ordinary skill in the art that the shapes of the containment areas are not limited only to those shown in the figures herein. The containment areas may have other shapes, such as ovals, stars, ellipses, pentagons, hexagons, trapezoids, or even non-geometric or fanciful shapes. Further, a single slide may have more than one particular shape of containment border disposed thereon, for example, a circle and a box or a pair of circles and a pair of boxes.

[**0025**] As is evident from the above, each slide contemplated herein has only a portion of the surface thereof coated with the coating material, with the specific purpose for retaining a liquid or liquid sample upon a discrete and predetermined portion of the slide.

[**0026**] In an alternative embodiment of the invention, one or more of the microscope slides or plates contemplated herein may be supplied as a kit along with other components used in microscopic analysis of samples. Said other components may comprise stains and reagents commonly used by those of ordinary skill, including but not limited to, stains, dyes, molecular biological reagents including monoclonal and polyclonal antibodies, and molecular probes and their detection reagents, and other aqueous and non-aqueous processing reagents. Examples of aqueous and non-aqueous processing reagents include xylene, toluene, acetone, and other organic and inorganic solvents, and alcohols, biological buffers, and aqueous reagents for use with antibodies, and molecular probes and their detection reagents.

[**0027**] Further, the examples described herein are not intended to limit the scope of the invention.

[**0028**] Changes may be made in the construction and the operation of the various components, elements and assemblies described herein or in the steps or the sequence of steps of the methods described herein without departing from the spirit and scope of the invention as defined in the following claims.

What is claimed is:

1. An analytic plate, comprising:

a plate constructed of a glass, plastic, or ceramic material and having an upper surface, a lower surface, a first side, a second side, and having a containment border surrounding at least a portion of a containment area of the plate, and wherein the containment border is invisible and has a thickness which is a substantially molecular layer.

2. The analytic plate of claim 1 further comprising a visible border on the lower surface and/or printed information on the upper surface and/or lower surface, the printed information comprising at least one of a line, number, or other symbol.

3. The analytic plate of claim 1 wherein the containment border completely surrounds the containment area of the plate.

4. The analytic plate of claim 1 wherein the containment border is formed from a coating material comprising a polysiloxane, siloxane, silicone, or silicon fluid composition or combinations thereof.

5. An analytic plate, comprising:

a glass, plastic or ceramic plate having an upper surface, lower surface, a first side and a second side, and having a containment border surrounding at least a portion of a containment area, and wherein the containment border is transparent and has a thickness which is a substantially molecular layer.

6. The analytic plate of claim 5 further comprising a visible border on the lower surface and/or printed information on the upper surface and/or lower surface, the printed information comprising at least one of a line, number, or other symbol.

7. The analytic plate of claim 5 wherein the containment border completely surrounds the containment area of the plate.

8. The analytic plate of claim 5 wherein the containment border is formed from a coating material comprising a polysiloxane, siloxane, silicone, or silicon fluid composition or combinations thereof.

9. A kit for microscopic analysis, comprising:

at least one analytic plate comprising:

a glass, plastic or ceramic plate having an upper surface, lower surface, a first side and a second side, and having a containment border surrounding at least a portion of a containment area, and wherein the containment border is transparent and has a thickness which is a substantially molecular layer; and

a reagent for treating a biological sample disposed upon the analytic plate.

10. The kit of claim 9 wherein the analytic plate further comprises a visible border on the lower surface and/or printed information on the upper surface and/or lower surface, the printed information comprising at least one of a line, number or symbol.

11. The kit of claim 9 wherein the containment border of the analytic plate is formed from a coating material comprising a polysiloxane, siloxane, silicone or silicon fluid composition or combinations thereof.

12. The kit of claim 9 wherein the containment border of the analytic plate completely surrounds the containment area of the plate.

13. The kit of claim 9 wherein the reagent is selected from a group of stains and biological reagents consistent with medical diagnosis comprising stains, dyes, aqueous and non-aqueous processing reagents, and molecular biological reagents and their detection reagents.

14. The kit of claim 13 wherein the aqueous and non-aqueous processing reagents further comprise xylene, toluene, acetone, alcohols, biological buffers, monoclonal and polyclonal antibodies, molecular probes and their detection reagents.

15. A kit for microscopic analysis, comprising:

at least one analytic plate comprising:

a glass, plastic or ceramic plate having an upper surface, lower surface, a first side and a second side, and having a containment border surrounding at least a portion of a containment area, and wherein the

containment border is invisible and has a thickness which is a substantially molecular layer; and

a reagent for treating a biological sample disposed upon the analytic plate.

16. The kit of claim 15 wherein the analytic plate further comprises a visible border on the lower surface and/or printed information on the upper surface and/or lower surface, the printed information comprising at least one of a line, number or symbol.

17. The kit of claim 15 wherein the containment border of the analytic plate is formed from a coating material comprising a polysiloxane, siloxane, silicone or silicon fluid composition or combinations thereof.

18. The kit of claim 15 wherein the containment border of the analytic plate completely surrounds the containment area of the plate.

19. The kit of claim 15 wherein the reagent is selected from a group of stains and biological reagents consistent with medical diagnosis comprising stains, dyes, aqueous and non-aqueous processing reagents, and molecular biological reagents and their detection reagents.

20. The kit of claim 19 wherein the aqueous and non-aqueous processing reagents further comprise xylene, toluene, acetone, alcohols, biological buffers, monoclonal and polyclonal antibodies, molecular probes and their detection reagents.

21. A method of using an analytic plate, comprising:

providing a glass, plastic or ceramic plate having an upper surface, a lower surface, a first side and a second side, and having a containment border surrounding at least a portion of a containment area, and wherein the containment border is transparent and has a thickness which is a substantially molecular layer; and

applying the liquid or liquid sample to the containment area of the plate.

22. The method of claim 21 wherein the liquid or liquid sample applied to the plate is selected from a group of stains and biological reagents consistent with medical diagnosis comprising stains, dyes, aqueous and non-aqueous processing reagents, and molecular biological reagents and their detection reagents.

23. The method of claim 22 wherein the liquid or liquid sample is an aqueous or non-aqueous processing reagent selected from the group consisting of xylene, toluene, acetone, alcohols, biological buffers, monoclonal and polyclonal antibodies, molecular probes and their detection reagents.

24. The method of claim 21 wherein the containment border of the analytic plate completely surrounds the containment area of the plate.

25. The method of claim 21 wherein in the step of providing a glass, plastic or ceramic plate, the containment border substantially prevents the migration of the aqueous or non-aqueous liquid or liquid sample from the containment area to portions of the upper surface of the plate outside of the containment border.

26. The method of claim 21 wherein the containment border of the plate is formed from a coating material comprising a polysiloxane, siloxane, silicone, or silicon fluid composition or combinations thereof.

27. The method of claim 21 wherein the plate further comprises a visible border on the lower surface and/or printed information on the upper surface and/or lower surface, the printed information comprising at least one of a line, number, or other symbol.

28. The method of claim 21 wherein the containment border of the plate is a substantially molecular layer.

29. A method of using an analytic plate, comprising:

providing a glass, plastic or ceramic plate having an upper surface, a lower surface, a first side and a second side, and having a containment border surrounding at least a portion of a containment area, and wherein the containment border is invisible and has a thickness which is a substantially molecular layer; and

applying the liquid or liquid sample to the containment area of the plate.

30. The method of claim 27 wherein the liquid or liquid sample applied to the plate is selected from a group of stains and biological reagents consistent with medical diagnosis comprising stains, dyes, aqueous and non-aqueous processing reagents, and molecular biological reagents and their detection reagents.

31. The method of claim 28 wherein the liquid or liquid sample is an aqueous or non-aqueous processing reagent selected from the group consisting of xylene, toluene, acetone, alcohols, biological buffers, monoclonal and polyclonal antibodies, molecular probes and their detection reagents.

32. The method of claim 27 wherein the containment border of the analytic plate completely surrounds the containment area of the plate.

33. The method of claim 27 wherein in the step of providing a glass, plastic or ceramic plate, the containment border substantially prevents the migration of the aqueous or non-aqueous liquid or liquid sample from the containment area to portions of the upper surface of the plate outside of the containment border.

34. The method of claim 27 wherein the containment border of the plate is formed from a coating material comprising a polysiloxane, siloxane, silicone, or silicon fluid composition or combinations thereof.

35. The method of claim 27 wherein the plate further comprises a visible border on the lower surface and/or printed information on the upper surface and/or lower surface, the printed information comprising at least one of a line, number, or other symbol.

* * * * *