



(51) International Patent Classification:
G01C 21/32 (2006.01) **G09B 29/10** (2006.01)
G06T 11/00 (2006.01)

(21) International Application Number: PCT/IB2015/052883

(22) International Filing Date: 20 April 2015 (20.04.2015)

(25) Filing Language: English

(26) Publication Language: English

(30) Priority Data:
 14/259,903 23 April 2014 (23.04.2014) US

(71) Applicant: **HERE GLOBAL B.V.** [NL/NL]; De Run
 1115, 5503 LB Veldhoven (NL).

(72) Inventors: **ALVAREZ TABIO TOGORES, Pedro**; 520 N Kingsbury St, Apt 1003, Chicago, Illinois 60654 (US). **CHINTAKINDI, Sunil Kumar**; 1524 Meadowland Drive, Naperville, Illinois 60540 (US). **CALKINS, Andrew**; 1228 Hollingswood Avenue, Naperville, Illinois 60540 (US). **HOEFFLER, Joy**; 2947 West Lyndale Street, Apartment #1, Chicago, Illinois 60647 (US).

(74) Agent: **NOKIA TECHNOLOGIES OY**; Karaportti 3, 02610 Espoo (FI).

(81) Designated States (unless otherwise indicated, for every kind of national protection available): AE, AG, AL, AM, AO, AT, AU, AZ, BA, BB, BG, BH, BN, BR, BW, BY, BZ, CA, CH, CL, CN, CO, CR, CU, CZ, DE, DK, DM, DO, DZ, EC, EE, EG, ES, FI, GB, GD, GE, GH, GM, GT, HN, HR, HU, ID, IL, IN, IR, IS, JP, KE, KG, KN, KP, KR, KZ, LA, LC, LK, LR, LS, LU, LY, MA, MD, ME, MG,

[Continued on next page]

(54) Title: DYNAMIC TRAFFIC RENDERING

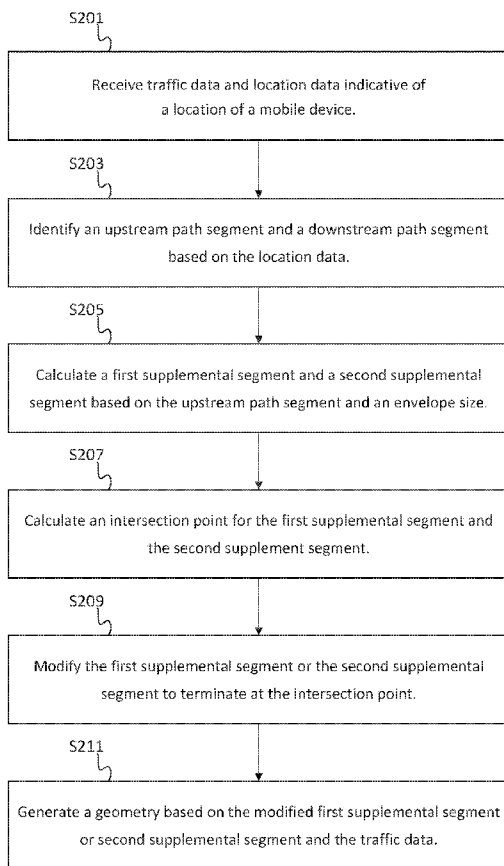

FIG. 10

(57) Abstract: An initial geometry including one dimensional representation of a path is accessed. The initial geometry may be based traffic data. An envelope size is identified based on the path. The envelope size may be derived from a width, functional classification, or lane quantity associated with the path. A processor calculates a supplemental geometry based on the envelope size for the path and generates a two dimensional representation of the path based on the initial geometry, the supplemental geometry, and the envelope size.





MK, MN, MW, MX, MY, MZ, NA, NG, NI, NO, NZ, OM, PA, PE, PG, PH, PL, PT, QA, RO, RS, RU, RW, SA, SC, SD, SE, SG, SK, SL, SM, ST, SV, SY, TH, TJ, TM, TN, TR, TT, TZ, UA, UG, US, UZ, VC, VN, ZA, ZM, ZW.

TJ, TM), European (AL, AT, BE, BG, CH, CY, CZ, DE, DK, EE, ES, FI, FR, GB, GR, HR, HU, IE, IS, IT, LT, LU, LV, MC, MK, MT, NL, NO, PL, PT, RO, RS, SE, SI, SK, SM, TR), OAPI (BF, BJ, CF, CG, CI, CM, GA, GN, GQ, GW, KM, ML, MR, NE, SN, TD, TG).

(84) Designated States (*unless otherwise indicated, for every kind of regional protection available*): ARIPO (BW, GH, GM, KE, LR, LS, MW, MZ, NA, RW, SD, SL, ST, SZ, TZ, UG, ZM, ZW), Eurasian (AM, AZ, BY, KG, KZ, RU,

Published:

— *with international search report (Art. 21(3))*

DYNAMIC TRAFFIC RENDERING

FIELD

[0001] The following disclosure relates to the designation of traffic lanes for a multi-lane path in traffic data, or more particularly, a two dimensional designation of traffic lanes based on a one dimensional path from traffic data.

BACKGROUND

[0002] Traffic technology is the study of movement of vehicles on the roads. Analytical techniques may manage and track traffic information and derive travel times, guide driving behavior and optimize road infrastructure for cities.

10 [0003] Traffic Message Channel (TMC) and other traffic services deliver traffic information to customers. Traffic incidents and traffic flow are reported through broadcasts. Traffic delays may be caused by one or more of congestion, construction, accidents, special events (e.g., concerts, sporting events, festivals), weather conditions (e.g., rain, snow, tornado), and so on.

[0004] In some areas, broadcast messages contain reports of traffic and road condition information. These systems broadcast the traffic data over traffic message channels on a continuous, periodic, or frequently occurring basis. Traffic message receivers decode the data and provide user friendly reports of traffic and road conditions.

[0005] In addition, traffic information may be overlaid on maps and encoding schemes that illustrate different traffic levels on the map. However, TMC and other traffic services broadcast data that does not directly overlay with the path location of the maps.

SUMMARY

[0006] An initial geometry including one dimensional representation of a path is accessed. The initial geometry may be based traffic data. An envelope size is identified based on the path. The envelope size may be derived from a width, functional classification, or lane quantity associated with the path. A processor calculates a supplemental geometry based on the envelope size for the path and generates a two dimensional representation of the path based on the initial geometry, the supplemental geometry, and the envelope size.

BRIEF DESCRIPTION OF THE DRAWINGS

- [0007] Exemplary embodiments of the present invention are described herein with reference to the following drawings.
- [0008] Figure 1 illustrates an example system for dynamic traffic rendering.
- [0009] Figure 2 illustrates example matching system for traffic rendering.
- 5 [0010] Figure 3A illustrates an example of one dimensional path geometry.
- [0011] Figure 3B illustrates the one dimensional path geometry of Figure 3A and envelope vectors.
- [0012] Figure 4A illustrates supplemental path geometries based on the envelope vectors of Figure 3B.
- 10 [0013] Figure 4B illustrates a modified path geometry based on the supplemental path geometries of Figure 4A.
- [0014] Figure 5 illustrates a maximum path geometry angle.
- [0015] Figure 6A and 6B illustrates example tables for envelope sizes.
- [0016] Figure 7 illustrates an exemplary server of the system of Figure 1.
- 15 [0017] Figure 8 illustrates example flowchart for traffic rendering.
- [0018] Figure 9 illustrates an exemplary mobile device of the system of Figure 1.
- [0019] Figure 10 illustrates another example flowchart for traffic rendering.

DETAILED DESCRIPTION

- [0020] One significant technical challenge for software applications for traffic data
20 visualizations is to render a full traffic flow map that is customizable to multiple types of traffic data feed formats. Location reference information, either through TMC (Traffic Messaging Channel) or other traffic services, may be included in many such traffic data feed formats. Data rendering techniques, such as portable network graphics (PNG) map tiles with integrated traffic or transparent PNG traffic overlays on top of the map, may not always be available for all traffic
25 feed formats.

[0021] The following embodiments address these shortcomings using a dynamic approach to render traffic flow information on maps based on vectorial geometry compatible with many different platforms. This approach relies on one or more of two key traffic visualization features.

First, path geometries are generated from a baseline traffic feed, instead of directly relying on a traditional map rendering service. Second, an envelope algorithm for bidirectional roads is applied. The resulting geometries may be associated with speed values or jam factors.

[0022] Figure 1 illustrates an example system 120 for dynamic traffic rendering. The system 5 120 includes a developer system 121, one or more mobile devices 122, a workstation 128, and a network 127. The system 120 may receive a flow of traffic data from a traffic service 110.

Additional, different, or fewer components may be provided. For example, many mobile devices 122 and/or workstations 128 connect with the network 127. The developer system 121 includes a server 125 and a database 123. The developer system 121 may include computer systems and 10 networks of a system operator.

[0023] The traffic service 110 may send traffic data to the map developer or directly to mobile devices 122. The traffic service 110 may be in TMC format and broadcast over a predetermined radio frequency or other wireless signals. The traffic data may include locations codes associated with event data or incident data. Any format of traffic data including location 15 codes may be used.

[0024] The server 125 receives user location data. The user location data may be received from one of the mobile device 122, in which case the location corresponds to a location of the mobile device 122 as determined by position circuitry such as a global positioning system (GPS). The location data may be received from workstation 128 as a location entered into a map 20 application. In another embodiment, the location data is selected systematically across a geographic area to dynamically render traffic representations of all available traffic data in the geographic area.

[0025] The server 125 is configured to access an initial geometry including one dimensional representation of a path. For example, the initial geometry may be a path segment that 25 corresponds to the location. The path segment may be selected from the database 123 (e.g., the closest path in the database 123 to the location). The path segment may be a portion of route selected by the mobile device 122 or the workstation 128.

[0026] The server 125 is configured to identify an envelope size associated with the path segment. The path segment may be associated with an identifier in the database 123. The identifier may include an alphanumeric code indicative of the functional classification of the path or the number of lanes of the path. The path segment may be a constant value for all types of segments. In one example, the envelope size may be variable according to the type of segment. In another example, the envelope size may be variable according to the number of lanes in the path segment. In another example, the envelope size may be variable according to the relative distance to other path segments near the location.

[0027] The server 125 is configured to calculate a supplemental geometry based on the envelope size for the path. The supplemental geometry may be spaced from the initial geometry by the envelope distance. The supplemental geometry may be parallel to the initial geometry. The server 125 is configured to generate a two dimensional representation of the path based on the initial geometry, the supplemental geometry, and the envelope size.

[0028] The mobile device 122 is a smart phone, a mobile phone, a personal digital assistant (“PDA”), a tablet computer, a notebook computer, a personal navigation device (“PND”), a portable navigation device, and/or any other known or later developed portable or mobile computing device. The mobile device 122 includes one or more detectors or sensors as a positioning system built or embedded into or within the interior of the mobile device 122. The mobile device 122 receives location data for geographic position from the positioning system.

[0029] The optional workstation 128 is a general purpose computer including programming specialized for the following embodiments. For example, the workstation 128 may receive user inputs for the envelope sizes for particular path segments or classifications of path segments. The workstation 128 may receive user inputs for manually defining the speed ranges for the color, shading, or alphanumeric labels for traffic designations of the path segment.

[0030] The developer system 121, the workstation 128, and the mobile device 122 are coupled with the network 127. The phrase “coupled with” is defined to mean directly connected to or indirectly connected through one or more intermediate components. Such intermediate components may include hardware and/or software-based components. The computing resources

may be divided between the server 125 and the mobile device 122. In some embodiments, the server 125 performs a majority of the processing. In other embodiments, the mobile device 122 or the workstation 128 performs a majority of the processing. In another example, the processing is divided substantially evenly between the server 125 and the mobile device 122 or workstation
5 128.

[0031] Figure 2 illustrates example matching system for traffic rendering. The matching system receives data from the traffic source 110 and the map developer 123. A matcher 133, which may be an independent device or an application executed by the server 125, combines traffic data received from the traffic source 110 and map geometries received from the map
10 developer 121 to dynamically render traffic geometries.

[0032] The matcher 133 may include a parser or parsing algorithm that is configured to parse or digest traffic feeds from the traffic source 110. The matcher 133 may match location codes in the traffic data from the traffic source 110 with locations in the map database 123. The locations from the map database may be selected in real time, or near real time, based on the location data
15 received from a particular mobile device 122.

[0033] The parsing algorithm may identify a primary TMC data and sub-TMC data from the traffic feed. The sub-TMC data may describe offset distances in order to apply different traffic values to a path assigned to a single TMC location code. The offset location may divide the path segment be in the longitudinal direction of the path segment (e.g., with traffic) into multiple
20 sections. The offset location splits the path segment into sections, which may be encoded with independent congestion levels and illustrated as having different congestion levels. For example, the sections of the path segment may be illustrated in different colors or shadings on a map.

[0034] The parsing algorithm may also distinguish between internal identification values and external identification values. Internal identification values are those related with the parts of a
25 TMC that belong to elements such as ramps, exits and incorporations to a highway. On the other hand, external identification values are those used for regular road segments. For that reason, the geometry of a TMC includes an internal section as well as an external one, and it is required to retrieve both to perform an adequate envelope calculation. Internal and external may have the

same ID number, but differ on the direction symbol. While external identification values have +/-, internal identification values have P/N, respectively for positive and negative directions.

[0035] As discussed in more detail below, an envelope algorithm is applied to paths to generate geometries and for the matched traffic data. The geometries may be stored in a fast, in-
5 memory cache for generalized, traffic service agnostic traffic flow data. This data may then be made available through a RESTful application programming interface (API) to any client side application. A client side application may apply the data through any specialized implementation, which may be based on polyline rendering.

[0036] Map 135 illustrates an example implementation in which locations codes from the
10 traffic source 110 defined in a single dimension have been converted into multi-lane paths dynamically rendered for traffic maps. The map includes two two-lane paths with varying traffic designations. The paths include light traffic areas 136, moderate traffic areas 137, and high traffic areas 138.

[0037] Figure 3A illustrates an example of one dimensional path geometry made of multiple
15 path segments 141a-b. Each path segment may be a vector defined by a location code or pair of location codes (e.g., from traffic service 110). For example, path segment 141a may be defined as a vector from an origin to location code (X_1, Y_1) , path segment 141b may be defined by a vector from location code (X_1, Y_1) to location code (X_2, Y_2) .

[0038] Figure 3B illustrates the one dimensional path geometry of Figure 3A and envelope
20 vectors 143a-b. The envelope vectors may be perpendicular or normal to the respective path segments 141a-b. The envelope vector u_1 is defined by path segment 141a and the envelope vector u_2 is defined by path segment 141b.

[0039] The direction of the envelope vectors 143a-b may depend on the local driving norms. In areas where driving occurs on the right hand side of the road, which may be referred to as right
25 hand traffic (RHT) locations, the envelope vector may be 90 degrees to the right or clockwise from the direction of the original vector of the path segment. In RHT locations, when the original direction vector is defined as (latitude value, longitude value), the envelope vector may be defined

as (-longitude value, latitude value). Thus, the envelope vector 143a is shown in the direction of (-X₁, Y₁) and the envelope vector 143b is shown in the direction of (-X₂, Y₂).

[0040] In areas where driving occurs on the left hand side of the road, which may be referred to as left hand traffic (LHT) locations, the envelope vector may be 90 degrees to the left or
 5 counterclockwise from the direction of the original vector of the path segment. Thus, in LHT locations, when the original direction vector is defined as (latitude value, longitude value), the envelope vector may be defined as (longitude value, -latitude value). Thus, the envelope vector 143a is shown in the direction of (-X₁, Y₁).

[0041] The server 125 may receive location data from the mobile device 122 and access a
 10 country database, which may be included in database 123, in order to determine if the current location of the mobile device is a LHT location or a RHT location. Most countries of the world are RHT locations, and notable examples of LHT locations include the United Kingdom, Australia, South Africa, Ireland, and India.

[0042] The envelope vectors 143a-b may be normalized to have unit length of 1 and describe
 15 direction only. Equation 1 describes the normalization of a vector $\vec{n} = (\text{latitude}, \text{longitude})$:

$$\vec{n}_{unit} = \frac{\vec{n}}{\sqrt{n_{lat}^2 + n_{lon}^2}}$$

Eq. 1

[0043] Figure 4A illustrates supplemental path geometries 144a-b based on the envelope
 vectors of Figure 3B. A supplemental path geometry is calculated based on a geometric
 translation of the original path segments 141a-b. The direction of the translation is defined by
 20 envelope vectors 143a-b, and the magnitude of the translation is defined by an envelope distance. The envelope distance may be constant or variable. Variable envelope distances may be user selectable or defined based on a characteristic of the original path segment.

[0044] As shown in region 145, the vectors for the supplemental path geometries 144a-b do
 not meet at the endpoints. In other words, the head one vector for one path segment does not align
 25 with the tail of the vector from the downstream path segment. This phenomenon may be referred

to as an open shape. The server 125 is configured to convert the original path segments 141a-b and supplemental path geometries 144a-b from an open shape to a closed shape.

[0045] Figure 4B illustrates a modified path geometry based on the supplemental path geometries of Figure 4A. In one example, the upstream vector is shortened and the downstream vector is elongated until the two vectors meet at a single point. This may be achieved through calculating the intersection point of the two vectors or the two supplemental path geometries 144a-b. The following pseudocode describes an algorithm for this process:

```

    If first and last points are not the same (open shape) then
        Insert first point in final geometry
    10   For each pair of lines, calculate intersection
        Insert last point in final geometry
    Else
        For each pair of lines, calculate intersection
        Calculate intersection for last and first line to close the shape

```

15 [0046] The supplemental path geometries 144a-b may be defined algebraically according to Equation 2 based on one intersection with an axis (C_{lat}, C_{lon}) and a direction vector (v).

$$(lat, lon) = kv + (C_{lat}, C_{lon}) \quad \text{Eq. 2}$$

[0047] Each of the supplemental path geometries 144a-b, if extended, intersects with at least one axis. Path geometries that are parallel to an axis would not intersect that axis, but would intersect the other axis, and most path geometries, if extended, would intersect both axes. Using linear algebra, Equations 3 and 4 describe the intersection of the supplemental path geometry of Equation 2. Equation 3 is derived by setting $C_{lon}=0$ as the point where the vector intersects the latitude axis. Equation 4 is derived by setting $C_{lat}=0$ as the point where the vector intersects the longitude axis. The coordinates (p_{lat}, p_{lon}) is known point (e.g., X_1, Y_1 or X_2, Y_2 as shown in Figures 4A-B).

$$\begin{bmatrix} p_{lat} \\ p_{lon} \end{bmatrix} = \begin{bmatrix} 1 & -v_{lat} \\ 0 & -v_{lon} \end{bmatrix} * \begin{bmatrix} c_{lat} \\ k \end{bmatrix} \quad \text{Eq. 3}$$

$$\begin{bmatrix} p_{lat} \\ p_{lon} \end{bmatrix} = \begin{bmatrix} 0 & -v_{lat} \\ 1 & -v_{lon} \end{bmatrix} * \begin{bmatrix} k \\ c_{lon} \end{bmatrix} \quad \text{Eq. 4}$$

[0048] Equation 3 and/or equation 4 may be applied to each of the supplemental path geometries 144a-b to create a system of equations shown in matrix format by Equation 5. It should be noted that only one of Equation 3 and 4 is needed. The server 125 may selection one of Equation 3 and 4 and switch to the other equation if no solution exists (e.g., when the path segment is parallel to the latitude axis or the longitude axis).

$$\begin{bmatrix} c_{2lat} - c_{1lat} \\ c_{2lon} - c_{1lon} \end{bmatrix} = \begin{bmatrix} v_{1lat} & -v_{2lat} \\ v_{1lon} & -v_{2lon} \end{bmatrix} * \begin{bmatrix} k_1 \\ k_2 \end{bmatrix} \quad \text{Eq. 5}$$

[0049] Figure 5 illustrates a maximum path geometry angle that may limit the envelope sizes available when creating the supplemental path geometries. The original path segments meet at a turn angle that corresponds to a turn in the path when traveling from the upstream path segment to the downstream path segment. For a path that continues substantially in a straight line, the original path segments are substantially parallel, and the turn angle is 0 degrees, or within a range of 0 degrees. Examples ranges include 0.5 degrees and 1 degrees.

[0050] When the turn angle is less than 90 degrees, the envelope size may be limited by a maximum envelope size d_{max} . Consider two original path segments 145a-b that meet an angle α , shown by Figure 5. The maximum envelope size d_{max} may be defined according to the lengths of path segments 145a-b and the length of a closing segment 146 that forms a triangle with path segments 145a-b. The maximum envelope size d_{max} may be defined according to a radius of an incircle formed by the triangle. Equations 6 and 7 define the maximum envelope size d_{max} as a function of a length (a) of an upstream path segment (e.g., path segment 145a), a length (b) of a downstream path segment (e.g., path segment 145b), and a length (c) of a closing segment.

$$d_{max} = \sqrt{\frac{(s-a)(s-b)(s-c)}{s}} \quad \text{Eq. 6}$$

$$s = \frac{1}{2}(a + b + c) \quad \text{Eq. 7}$$

[0051] The server 125 may compare the envelope size to the maximum envelope size. When the envelope size is less than the maximum envelope size, the server 125 proceeds to calculate the

supplemental geometries as described above, and modify the supplemental path geometries. The path geometries may be reduced in size to terminate at the intersection point as solved from Equations 2-5.

5 [0052] However, if the envelope size is equal or greater than the maximum envelope size, the server 125 may calculate a substitution segment for one or a combination of both supplemental path geometries, or for the original path geometries. In one example, the server 125 may calculate the closing segment 146 that forms a triangle with path segments 145a-b. The envelope vector may be applied to closing segment 146 and the path segments 145a-b may be omitted

10 [0053] Figure 6A and 6B illustrates example lookup tables for envelope sizes. The server 125 may identify the functional class of the path segment from data included in the database 123. The server 125 may assign an envelope size to the path segment based on the functional classification. The server 125 may identify a number of lanes for the path segment from the database 123. The server 125 may assign an envelope size to the path segment based on the number of lanes. The server 125 may assign an envelope size to the path segment based on a combination of the functional class and the number of lanes.

[0054] The envelope size may include a default size. The default size may be defined in terms of a geographic distance, a scale distance on a map, or a display distance on the mobile device 122. Example default sizes defined by geographic distance include 20, 35.3, 50, or 100 microdegrees. If a circumference of the Earth is divided into 360 degrees or 3600 seconds, a microdegree (μdeg) is a unit of angle measurement equal to 10^{-6} degrees, or 3.6 milliarcseconds.

[0055] The table 150 of Figure 6A illustrates a correlation between functional class and envelope factor. The envelope factor is multiplied by the default size to calculate the envelope size for a particular road segment.

25 [0056] The table 155 of Figure 6B illustrates a correlation between functional class and the number of lanes to calculate an envelope size. It should be noted when two path segments in the same functional class have different numbers of lanes, the path segment with the larger number of lanes has a greater envelope size. It should also be noted than when two path segments have the

same number of lanes but are different functional classes, the path segment in the lower numbered (higher priority) functional class, has a greater envelope size. Other assignments for the envelope size are possible.

[0057] Table 1 lists example classification systems that may be assigned numeric values for functional class as shown in Figures 6A and 6B.

Simple System	Complex System	U.S. Long Distance Roads	Highway Tags
Arterial Road	Interstates	Interstate Expressway	Motorway
Collector Road	Principal Arteries	Federal Highway	Trunk
Local Road	Minor Arteries	State Highway	Primary
	Major Collector	County Highway	Secondary
	Minor Collector	Local Road	Tertiary
	Local Road		Residential

Table 1

[0058] One example of a simple system includes the functional classification maintained by the United States Federal Highway administration. The simple system includes arterial roads, collector roads, and local roads. The functional classifications of roads balance between accessibility and speed. An arterial road has low accessibility but is the fastest mode of travel between two points. Arterial roads are typically used for long distance travel. Collector roads connect arterial roads to local roads. Collector roads are more accessible and slower than arterial roads. Local roads are accessible to individual homes and business. Local roads are the most accessible and slowest type of road.

[0059] An example of a complex functional classification system is the urban classification system. Interstates include high speed and controlled access roads that span long distances. The arterial roads are divided into principle arteries and minor arteries according to size. The collector roads are divided into major collectors and minor collectors according to size.

[0060] Another example functional classification system divides long distance roads by type of road or the entity in control of the highway. The functional classification system includes interstate expressways, federal highways, state highways, local highways, and local access roads. Another functional classification system uses the highway tag system in the Open Street Map

(OSM) system. The functional classification includes motorways, trunk roads, primary roads, secondary roads, tertiary roads, and residential roads.

[0061] Alternatively, the database 123 may list road width or lane quantities. The server 125 may access the database for the road width according to the geographic location reported by the mobile device 122. The road width may be used as an initial value of the target route.

[0062] Figure 7 illustrates an exemplary server 125 of the system of Figure 1. The server 125 includes a processor 300, a communication interface 305, and a memory 301. The server 125 may be coupled to a database 123 and a workstation 310. The workstation 310 may be used as an input device for the server 125. In addition, the communication interface 305 is an input device for the server 125. The communication interface 305 receives data indicative of use inputs made via the workstation 128 or the mobile device 122. Additional, different, or fewer components may be included. Figure 8 illustrates an example flowchart for dynamic traffic rendering. The acts of Figure 8 may be performed by the server 125 or another device. Additional, different, or fewer acts may be provided.

[0063] At act S101, the processor 300 derives an initial geometry including one dimensional representation of a path. The initial geometry may include multiple segments or a single segment. The initial geometry may be received through communication interface 305 from workstation 310 or another external device. The initial geometry may be derived from location codes received from a traffic service or from TMC data. For example, the initial geometry may be a one dimensional line drawn from one location code to a subsequent location code.

[0064] At act S103, the processor 300 identifies an envelope size associated with the path. The envelope size may be determined by querying database 123 using the location codes from the traffic service. The database 123 may associate segments in the map data with identifiers that describe functional classifications, path width, lane quantities, or other values indicative of the envelope size of the paths.

[0065] At act S105, the processor 300 calculates a supplemental geometry based on the envelope size for the path. The supplemental geometry may include a portion that corresponds to

each segments of the initial geometry. The supplemental geometry may be multiple lines parallel to the initial geometry and spaced from the initial geometry by the envelope size.

[0066] At act S107, the processor 300 calculates an intersection of the multiple lines of the supplemental geometry. The processor 300 may solve the intersection using geometry or linear algebra. The algebraic method may include a matrix derived from the lines of the supplemental geometry.

[0067] At act S109, the processor 300 generates a two dimensional representation of the path based on the intersection of the first line segment and the second line segment. In one example, the processor 300 may modify one or more lengths of the lines making up the supplemental geometry based on the intersection. The line of the supplemental geometry may be shortened until the lines each terminate at a single point.

[0068] Figure 9 illustrates an exemplary mobile device 122 of the system of Figure 1. The mobile device 122 may be referred to as a navigation device. The mobile device 122 includes a controller 200, a memory 201, an input device 203, a communication interface 205, position circuitry 207, and a display 211. The workstation 128 may include at least a memory and processor and may be substituted for the mobile device in the following. Figure 10 illustrates an example flowchart for dynamic traffic rendering. The acts of Figure 10 may be performed by the mobile device 122 or another device. Additional, different, or fewer acts may be provided.

[0069] At act S201, the controller 200 may receive traffic data and location data indicative of a location of the mobile device 122 from memory 201. The traffic data may be originally received from a traffic service. The location data may be originally derived from position circuitry 207.

[0070] At act S203, the controller 200 may identify an upstream path segment and a downstream path segment based on the location data. The upstream path may be the current path segment that the mobile device 122 is traveling on, and the downstream segment may be the next path segment if the mobile device 122 continues to travel on the current route. The controller 200 may identify multiple subsequent downstream paths (e.g., when there is a fork in the upstream path or a traffic intersection at the terminal end of the upstream segment).

[0071] At act S205, the controller 200 may calculate a supplemental segment based on the upstream path segment and another supplemental segment based on the downstream path. The supplemental paths may be lines parallel to the upstream and downstream paths. The supplemental paths may be spaced apart from the upstream and downstream paths by an envelope distance.

[0072] The envelope distance may be defined according to the type of paths associated with the upstream and downstream path segments. The envelope sizes may be the same or different. The envelope size may be a function of classification of the paths, the number of lanes of the paths, or a combination of both.

10 [0073] At act S207, the controller 200 calculates an intersection point for the first supplemental segment and the second supplemental segment. The intersection point may be calculated geometrically, algebraically, or through trial and error. At S209, the controller 200 modifies the first supplemental segment or the second supplemental segment to terminate at the intersection point. At S211, the controller 200 generates a shape of geometry based on the
15 modified first supplemental segment or second supplemental segment and the traffic data. The geometry may be two-dimensional and in the shape of a road as shown by map 135. The geometry may include colors, shadings, or other indicia that represents the traffic data received from the traffic service 110.

[0074] In addition or the alternative to traffic reporting, the traffic values may be used to
20 provide functions for an autonomous vehicle. An autonomous vehicle is self-driving and may be referred to as a robot vehicle or an automated vehicle. The autonomous vehicle may include passengers but no driver is necessary. The mobile device 122 or another computer system in communication with the mobile device 122 may include instructions for routing the vehicle or operating the vehicle. An estimated travel time may be calculated based on the traffic values and a
25 route may be chosen based on the estimate travel time. The computing system may generate driving commands for steering the vehicle, shifting gears, increasing and decreasing the throttle, and braking. The computing system may generate auxiliary commands for controlling the

headlights, turn signals, windshield wipers, defrost, or other auxiliary functions not directly related to the movement of the vehicle.

[0075] The autonomous vehicle may include sensors for identifying the surrounding and location of the car. The sensors may include GPS, light detection and ranging (LIDAR), radar, and cameras for computer vision. Proximity sensors may aid in parking the vehicle. The proximity sensors may detect the curb or adjacent vehicles. The autonomous vehicle may optically track and follow lane markings or guide markings on the road.

[0076] The database 123 may store or maintain geographic data such as, for example, road segment or link data records and node data records. The link data records are links or segments representing the roads, streets, or paths. The node data records are end points (e.g., intersections) corresponding to the respective links or segments of the road segment data records. The road link data records and the node data records may represent, for example, road networks used by vehicles, cars, and/or other entities. The road link data records may be associated with attributes of or about the roads such as, for example, geographic coordinates, street names, address ranges, speed limits, turn restrictions at intersections, and/or other navigation related attributes (e.g., one or more of the road segments is part of a highway or tollway, the location of stop signs and/or stoplights along the road segments), as well as points of interest (POIs), such as gasoline stations, hotels, restaurants, museums, stadiums, offices, automobile dealerships, auto repair shops, buildings, stores, parks, etc. The node data records may be associated with attributes (e.g., about the intersections) such as, for example, geographic coordinates, street names, address ranges, speed limits, turn restrictions at intersections, and other navigation related attributes, as well as POIs such as, for example, gasoline stations, hotels, restaurants, museums, stadiums, offices, automobile dealerships, auto repair shops, buildings, stores, parks, etc. The geographic data may additionally or alternatively include other data records such as, for example, POI data records, topographical data records, cartographic data records, routing data, and maneuver data.

[0077] The databases 123 may be maintained by one or more map developers (e.g., the first company and/or the second company). A map developer collects geographic data to generate and enhance the database. There are different ways used by the map developer to collect data. These

ways include obtaining data from other sources such as municipalities or respective geographic authorities. In addition, the map developer may employ field personnel (e.g., the employees at the first company and/or the second company) to travel by vehicle along roads throughout the geographic region to observe features and/or record information about the features. Also, remote
5 sensing such as, for example, aerial or satellite photography may be used.

[0078] The database 123 may be master geographic databases stored in a format that facilitates updating, maintenance, and development. For example, a master geographic database or data in the master geographic database is in an Oracle spatial format or other spatial format, such as for development or production purposes. The Oracle spatial format or
10 development/production database may be compiled into a delivery format such as a geographic data file (GDF) format. The data in the production and/or delivery formats may be compiled or further compiled to form geographic database products or databases that may be used in end user navigation devices or systems.

[0079] For example, geographic data is compiled (such as into a physical storage format
15 (PSF) format) to organize and/or configure the data for performing navigation-related functions and/or services, such as route calculation, route guidance, map display, speed calculation, distance and travel time functions, and other functions, by a navigation device. The navigation-related functions may correspond to vehicle navigation, pedestrian navigation, or other types of navigation. The compilation to produce the end user databases may be performed by a party or
20 entity separate from the map developer. For example, a customer of the map developer, such as a navigation device developer or other end user device developer, may perform compilation on a received geographic database in a delivery format to produce one or more compiled navigation databases.

[0080] The input device 203 may be one or more buttons, keypad, keyboard, mouse, stylist
25 pen, trackball, rocker switch, touch pad, voice recognition circuit, or other device or component for inputting data to the mobile device 122. The input device 203 and the display 211 may be combined as a touch screen, which may be capacitive or resistive. The display 211 may be a

liquid crystal display (LCD) panel, light emitting diode (LED) screen, thin film transistor screen, or another type of display.

[0081] The positioning circuitry 207 is optional and may be excluded for the map-related functions. The positioning circuitry 207 may include GPS, Global Navigation Satellite System (GLONASS), or a cellular or similar position sensor for providing location data. The positioning system may utilize GPS-type technology, a dead reckoning-type system, cellular location, or combinations of these or other systems. The positioning circuitry 207 may include suitable sensing devices that measure the traveling distance, speed, direction, and so on, of the mobile device 122. The positioning system may also include a receiver and correlation chip to obtain a GPS signal. Alternatively or additionally, the one or more detectors or sensors may include an accelerometer built or embedded into or within the interior of the mobile device 122. The accelerometer is operable to detect, recognize, or measure the rate of change of translational and/or rotational movement of the mobile device 122. The mobile device 122 receives location data from the positioning system. The location data indicates the location of the mobile device 122.

[0082] The controller 200 and/or processor 300 may include a general processor, digital signal processor, an application specific integrated circuit (ASIC), field programmable gate array (FPGA), analog circuit, digital circuit, combinations thereof, or other now known or later developed processor. The controller 200 and/or processor 300 may be a single device or combinations of devices, such as associated with a network, distributed processing, or cloud computing.

[0083] The memory 201 and/or memory 301 may be a volatile memory or a non-volatile memory. The memory 201 and/or memory 301 may include one or more of a read only memory (ROM), random access memory (RAM), a flash memory, an electronic erasable program read only memory (EEPROM), or other type of memory. The memory 201 and/or memory 301 may be removable from the mobile device 100, such as a secure digital (SD) memory card.

[0084] The communication interface 205 and/or communication interface 305 may include any operable connection. An operable connection may be one in which signals, physical

communications, and/or logical communications may be sent and/or received. An operable connection may include a physical interface, an electrical interface, and/or a data interface. The communication interface 205 and/or communication interface 305 provides for wireless and/or wired communications in any now known or later developed format.

5 [0085] The network 127 may include wired networks, wireless networks, or combinations thereof. The wireless network may be a cellular telephone network, an 802.11, 802.16, 802.20, or WiMax network. Further, the network 127 may be a public network, such as the Internet, a private network, such as an intranet, or combinations thereof, and may utilize a variety of networking protocols now available or later developed including, but not limited to TCP/IP based networking
10 protocols.

[0086] While the non-transitory computer-readable medium is shown to be a single medium, the term "computer-readable medium" includes a single medium or multiple media, such as a centralized or distributed database, and/or associated caches and servers that store one or more sets of instructions. The term "computer-readable medium" shall also include any medium that is
15 capable of storing, encoding or carrying a set of instructions for execution by a processor or that cause a computer system to perform any one or more of the methods or operations disclosed herein.

[0087] In a particular non-limiting, exemplary embodiment, the computer-readable medium can include a solid-state memory such as a memory card or other package that houses one or more
20 non-volatile read-only memories. Further, the computer-readable medium can be a random access memory or other volatile re-writable memory. Additionally, the computer-readable medium can include a magneto-optical or optical medium, such as a disk or tapes or other storage device to capture carrier wave signals such as a signal communicated over a transmission medium. A digital file attachment to an e-mail or other self-contained information archive or set of archives
25 may be considered a distribution medium that is a tangible storage medium. Accordingly, the disclosure is considered to include any one or more of a computer-readable medium or a distribution medium and other equivalents and successor media, in which data or instructions may be stored.

[0088] In an alternative embodiment, dedicated hardware implementations, such as application specific integrated circuits, programmable logic arrays and other hardware devices, can be constructed to implement one or more of the methods described herein. Applications that may include the apparatus and systems of various embodiments can broadly include a variety of electronic and computer systems. One or more embodiments described herein may implement functions using two or more specific interconnected hardware modules or devices with related control and data signals that can be communicated between and through the modules, or as portions of an application-specific integrated circuit. Accordingly, the present system encompasses software, firmware, and hardware implementations.

10 [0089] In accordance with various embodiments of the present disclosure, the methods described herein may be implemented by software programs executable by a computer system. Further, in an exemplary, non-limited embodiment, implementations can include distributed processing, component/object distributed processing, and parallel processing. Alternatively, virtual computer system processing can be constructed to implement one or more of the methods or functionality as described herein.

[0090] Although the present specification describes components and functions that may be implemented in particular embodiments with reference to particular standards and protocols, the invention is not limited to such standards and protocols. For example, standards for Internet and other packet switched network transmission (e.g., TCP/IP, UDP/IP, HTML, HTTP, HTTPS) represent examples of the state of the art. Such standards are periodically superseded by faster or more efficient equivalents having essentially the same functions. Accordingly, replacement standards and protocols having the same or similar functions as those disclosed herein are considered equivalents thereof.

[0091] A computer program (also known as a program, software, software application, script, or code) can be written in any form of programming language, including compiled or interpreted languages, and it can be deployed in any form, including as a standalone program or as a module, component, subroutine, or other unit suitable for use in a computing environment. A computer program does not necessarily correspond to a file in a file system. A program can be

stored in a portion of a file that holds other programs or data (e.g., one or more scripts stored in a markup language document), in a single file dedicated to the program in question, or in multiple coordinated files (e.g., files that store one or more modules, sub programs, or portions of code). A computer program can be deployed to be executed on one computer or on multiple computers that are located at one site or distributed across multiple sites and interconnected by a communication network.

[0092] The processes and logic flows described in this specification can be performed by one or more programmable processors executing one or more computer programs to perform functions by operating on input data and generating output. The processes and logic flows can also be performed by, and apparatus can also be implemented as, special purpose logic circuitry, e.g., an FPGA (field programmable gate array) or an ASIC (application specific integrated circuit).

[0093] As used in this application, the term ‘circuitry’ or ‘circuit’ refers to all of the following: (a) hardware-only circuit implementations (such as implementations in only analog and/or digital circuitry) and (b) to combinations of circuits and software (and/or firmware), such as (as applicable): (i) to a combination of processor(s) or (ii) to portions of processor(s)/software (including digital signal processor(s)), software, and memory(ies) that work together to cause an apparatus, such as a mobile phone or server, to perform various functions) and (c) to circuits, such as a microprocessor(s) or a portion of a microprocessor(s), that require software or firmware for operation, even if the software or firmware is not physically present.

[0094] This definition of ‘circuitry’ applies to all uses of this term in this application, including in any claims. As a further example, as used in this application, the term “circuitry” would also cover an implementation of merely a processor (or multiple processors) or portion of a processor and its (or their) accompanying software and/or firmware. The term “circuitry” would also cover, for example and if applicable to the particular claim element, a baseband integrated circuit or applications processor integrated circuit for a mobile phone or a similar integrated circuit in server, a cellular network device, or other network device.

[0095] Processors suitable for the execution of a computer program include, by way of example, both general and special purpose microprocessors, and anyone or more processors of any kind of digital computer. Generally, a processor receives instructions and data from a read only memory or a random access memory or both. The essential elements of a computer are a
5 processor for performing instructions and one or more memory devices for storing instructions and data. Generally, a computer also includes, or be operatively coupled to receive data from or transfer data to, or both, one or more mass storage devices for storing data, e.g., magnetic, magneto optical disks, or optical disks. However, a computer need not have such devices. Moreover, a computer can be embedded in another device, e.g., a mobile telephone, a personal
10 digital assistant (PDA), a mobile audio player, a Global Positioning System (GPS) receiver, to name just a few. Computer readable media suitable for storing computer program instructions and data include all forms of non-volatile memory, media and memory devices, including by way of example semiconductor memory devices, e.g., EPROM, EEPROM, and flash memory devices; magnetic disks, e.g., internal hard disks or removable disks; magneto optical disks; and CD ROM
15 and DVD-ROM disks. The processor and the memory can be supplemented by, or incorporated in, special purpose logic circuitry.

[0096] To provide for interaction with a user, embodiments of the subject matter described in this specification can be implemented on a device having a display, e.g., a CRT (cathode ray tube) or LCD (liquid crystal display) monitor, for displaying information to the user and a keyboard and
20 a pointing device, e.g., a mouse or a trackball, by which the user can provide input to the computer. Other kinds of devices can be used to provide for interaction with a user as well; for example, feedback provided to the user can be any form of sensory feedback, e.g., visual feedback, auditory feedback, or tactile feedback; and input from the user can be received in any form, including acoustic, speech, or tactile input.

25 [0097] Embodiments of the subject matter described in this specification can be implemented in a computing system that includes a back end component, e.g., as a data server, or that includes a middleware component, e.g., an application server, or that includes a front end component, e.g., a client computer having a graphical user interface or a Web browser through which a user can

interact with an implementation of the subject matter described in this specification, or any combination of one or more such back end, middleware, or front end components. The components of the system can be interconnected by any form or medium of digital data communication, e.g., a communication network. Examples of communication networks include a
5 local area network (“LAN”) and a wide area network (“WAN”), e.g., the Internet.

[0098] The computing system can include clients and servers. A client and server are generally remote from each other and typically interact through a communication network. The relationship of client and server arises by virtue of computer programs running on the respective computers and having a client-server relationship to each other.

10 **[0099]** The illustrations of the embodiments described herein are intended to provide a general understanding of the structure of the various embodiments. The illustrations are not intended to serve as a complete description of all of the elements and features of apparatus and systems that utilize the structures or methods described herein. Many other embodiments may be apparent to those of skill in the art upon reviewing the disclosure. Other embodiments may be
15 utilized and derived from the disclosure, such that structural and logical substitutions and changes may be made without departing from the scope of the disclosure. Additionally, the illustrations are merely representational and may not be drawn to scale. Certain proportions within the illustrations may be exaggerated, while other proportions may be minimized. Accordingly, the disclosure and the figures are to be regarded as illustrative rather than restrictive.

20 **[00100]** While this specification contains many specifics, these should not be construed as limitations on the scope of the invention or of what may be claimed, but rather as descriptions of features specific to particular embodiments of the invention. Certain features that are described in this specification in the context of separate embodiments can also be implemented in combination in a single embodiment. Conversely, various features that are described in the context of a single
25 embodiment can also be implemented in multiple embodiments separately or in any suitable sub-combination. Moreover, although features may be described above as acting in certain combinations and even initially claimed as such, one or more features from a claimed

combination can in some cases be excised from the combination, and the claimed combination may be directed to a sub-combination or variation of a sub-combination.

[00101] Similarly, while operations are depicted in the drawings and described herein in a particular order, this should not be understood as requiring that such operations be performed in
5 the particular order shown or in sequential order, or that all illustrated operations be performed, to achieve desirable results. In certain circumstances, multitasking and parallel processing may be advantageous. Moreover, the separation of various system components in the embodiments described above should not be understood as requiring such separation in all embodiments, and it should be understood that the described program components and systems can generally be
10 integrated together in a single software product or packaged into multiple software products.

[00102] One or more embodiments of the disclosure may be referred to herein, individually and/or collectively, by the term “invention” merely for convenience and without intending to voluntarily limit the scope of this application to any particular invention or inventive concept. Moreover, although specific embodiments have been illustrated and described herein, it should be
15 appreciated that any subsequent arrangement designed to achieve the same or similar purpose may be substituted for the specific embodiments shown. This disclosure is intended to cover any and all subsequent adaptations or variations of various embodiments. Combinations of the above embodiments, and other embodiments not specifically described herein, are apparent to those of skill in the art upon reviewing the description.

[00103] The Abstract of the Disclosure is provided to comply with 37 C.F.R. §1.72(b) and is submitted with the understanding that it will not be used to interpret or limit the scope or meaning of the claims. In addition, in the foregoing Detailed Description, various features may be grouped together or described in a single embodiment for the purpose of streamlining the disclosure. This disclosure is not to be interpreted as reflecting an intention that the claimed embodiments require
25 more features than are expressly recited in each claim. Rather, as the following claims reflect, inventive subject matter may be directed to less than all of the features of any of the disclosed embodiments. Thus, the following claims are incorporated into the Detailed Description, with each claim standing on its own as defining separately claimed subject matter.

[00104] It is intended that the foregoing detailed description be regarded as illustrative rather than limiting and that it is understood that the following claims including all equivalents are intended to define the scope of the invention. The claims should not be read as limited to the described order or elements unless stated to that effect. Therefore, all embodiments that come
5 within the scope and spirit of the following claims and equivalents thereto are claimed as the invention.

WE CLAIM:

1. A method comprising:
 - accessing an initial geometry including one dimensional representation of a path;
 - identifying an envelope size associated with the path;
 - calculating using a processor, a supplemental geometry based on the envelope size for the path; and
 - generating, using the processor, a two dimensional representation of the path based on the initial geometry, the supplemental geometry, and the envelope size.
2. The method of claim 1, further comprising:
 - querying a geographic database for the path; and
 - determining the envelope size based on an identifier for the path.
3. The method of claim 2, wherein the geographic database indexes paths according to functional classification included in the identifier.
4. The method of claim 3, wherein the envelope size for a first functional class exceeds the envelope size for a second functional class.
5. The method of claim 2, wherein the geographic database indexes paths according to data indicative of a number of lanes for the path.
6. The method of claim 1, wherein the supplemental geometry is calculated based on a direction of traffic.
7. The method of claim 1, wherein the path is a first path, the method further comprising:
 - accessing an initial geometry including one dimensional representation of a second path;
 - calculating an intersection point of the first path and the second path;
 - modifying a length of the first path based on the intersection point; and
 - modifying a length of the second path based on the intersection point.
8. The method of claim 7, further comprising:
 - calculating a maximum envelope size based on lengths of the first path and the second path.

9. The method of claim 8, further comprising:
 - identifying a closing segment that forms a triangle with the first path and the second path;
 - and
 - generating a two dimensional representation of the first path and the second path based on the envelope size and the closing segment.

10. An apparatus comprising:
 - at least one processor; and
 - at least one memory including computer program code for one or more programs; the at least one memory and the computer program code configured to, with the at least one processor, cause the apparatus to at least perform:
 - deriving an initial geometry including one dimensional representation of a path;
 - identifying an envelope size associated with the path;
 - calculating a supplemental geometry based on the envelope size for the path, wherein the supplemental geometry includes a first line segment and a second line segment;
 - calculating an intersection of the first line segment and the second line segment; and
 - generating a two dimensional representation of the path based on the intersection of the first line segment and the second line segment.

11. The apparatus of claim 10, further comprising:
 - querying a geographic database for the path; and
 - determining the envelope size based on a classification for the path.

12. The apparatus of claim 11, wherein the geographic database stores classifications including artery, collector, and local.

13. The apparatus of claim 11, wherein the geographic database stores classification based on a number of lanes.

14. The apparatus of claim 10, wherein the at least one memory and the computer program code configured to, with the at least one processor, cause the apparatus to at least perform:
 - receiving location data, wherein the initial geometry is accessed based on the location data; and
 - accessing a driving direction value, wherein the two dimensional representation of the path is based on the driving direction value.

15. The apparatus of claim 10, wherein the at least one memory and the computer program code configured to, with the at least one processor, cause the apparatus to at least perform:
modifying a length of the first line segment based on the intersection; and
modifying a length of the second line segment based on the intersection.
16. The apparatus of claim 10, wherein the at least one memory and the computer program code configured to, with the at least one processor, cause the apparatus to at least perform:
calculating a maximum envelope size based on lengths of a first portion of the path and a second portion of the path.
17. The apparatus of claim 16, wherein the at least one memory and the computer program code configured to, with the at least one processor, cause the apparatus to at least perform:
identifying a closing segment that forms a triangle with the first portion and the second portion; and
generating a two dimensional representation of the path based on the envelope size and the closing segment.
18. A method comprising:
receiving traffic data and location data indicative of a location of a mobile device;
identifying an upstream path segment and a downstream path segment based on the location data;
calculating, by a processor, a first supplemental segment based on the upstream path segment and a first envelope size;
calculating, by the processor, a second supplemental segment based on the downstream path segment and a second envelope size;
calculating, by the processor, an intersection point for the first supplemental segment and the second supplemental segment;
modifying the first supplemental segment or the second supplemental segment to terminate at the intersection point; and
generating a geometry based on the modified first supplemental segment or second supplemental segment and the traffic data.
19. The method of claim 18, wherein the first envelope size is equal to the second envelope size.

20. The method of claim 18, wherein the first envelope size is based on a functional classification of the upstream path segment and the second envelope size is based on a functional classification of the downstream path segment.

120

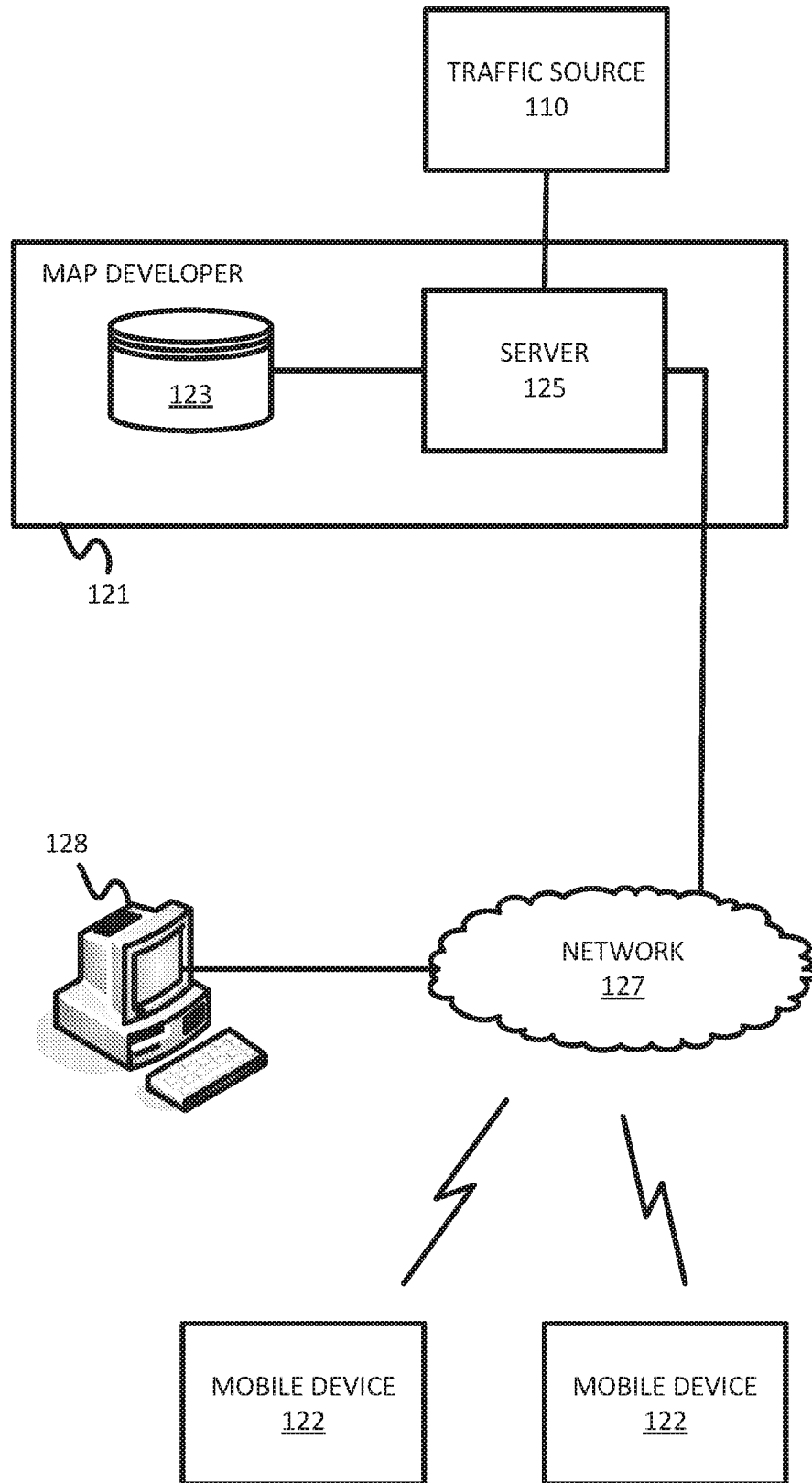

FIG. 1

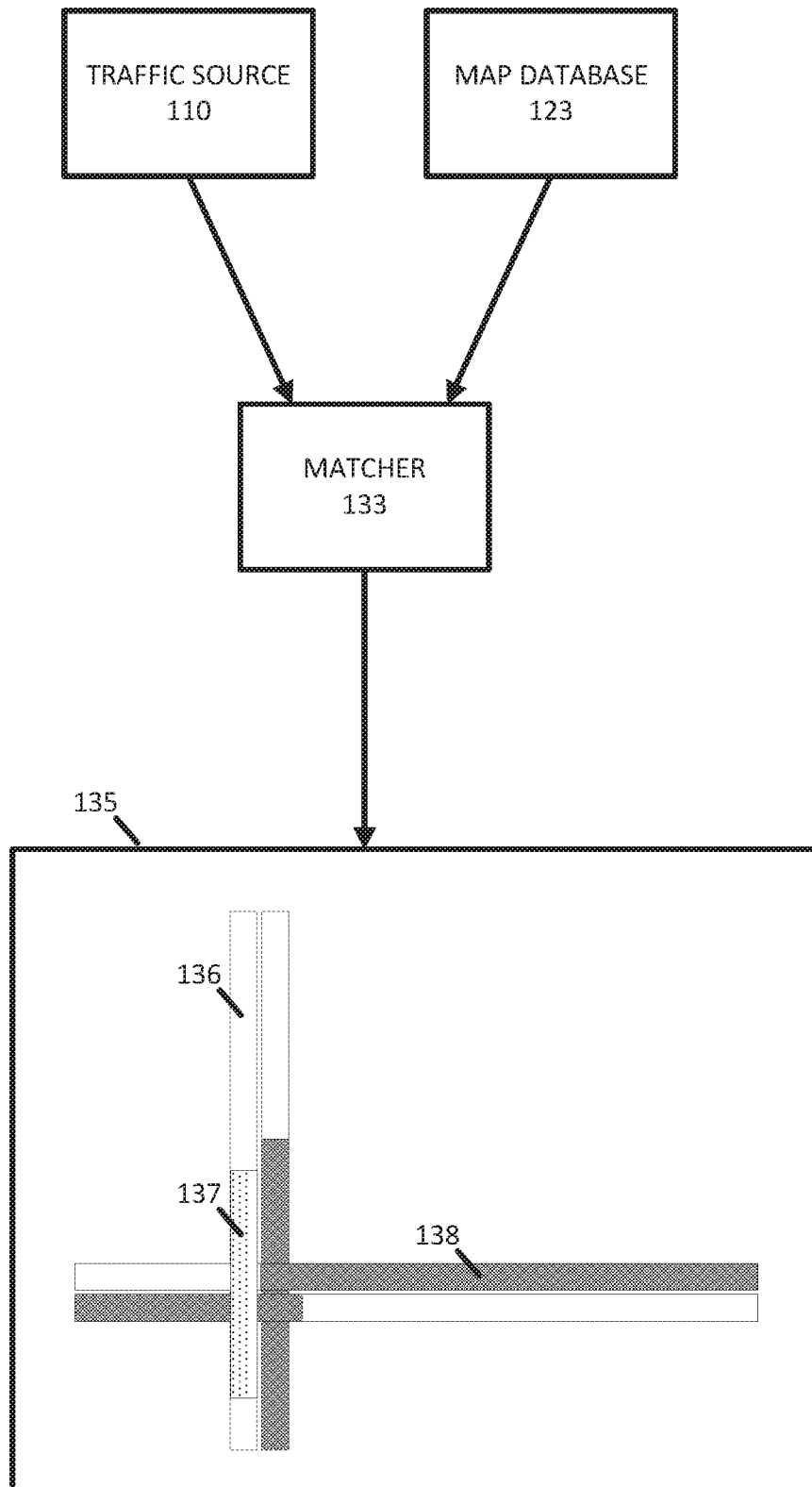

FIG. 2

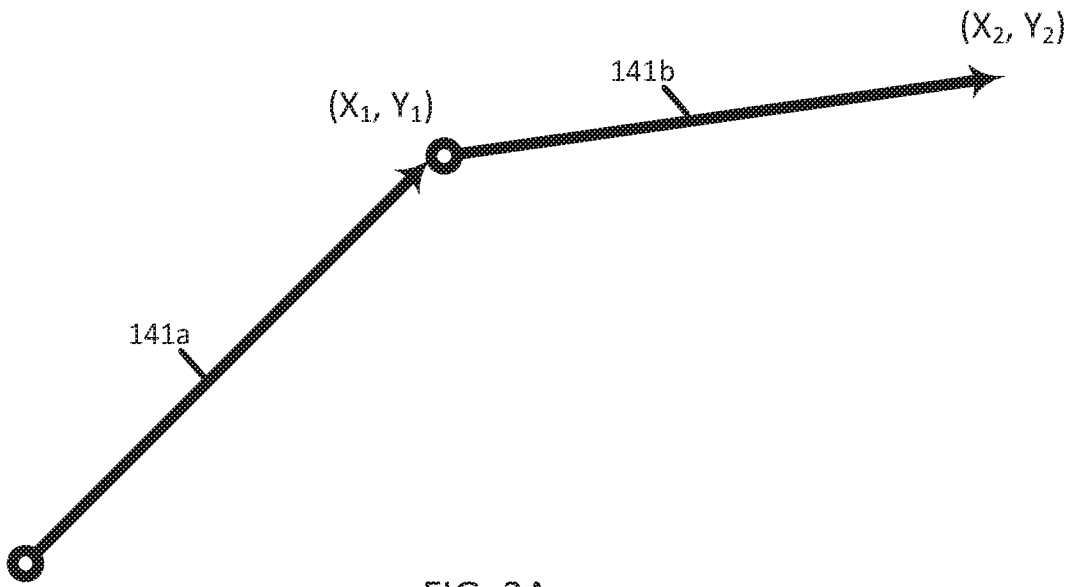

FIG. 3A

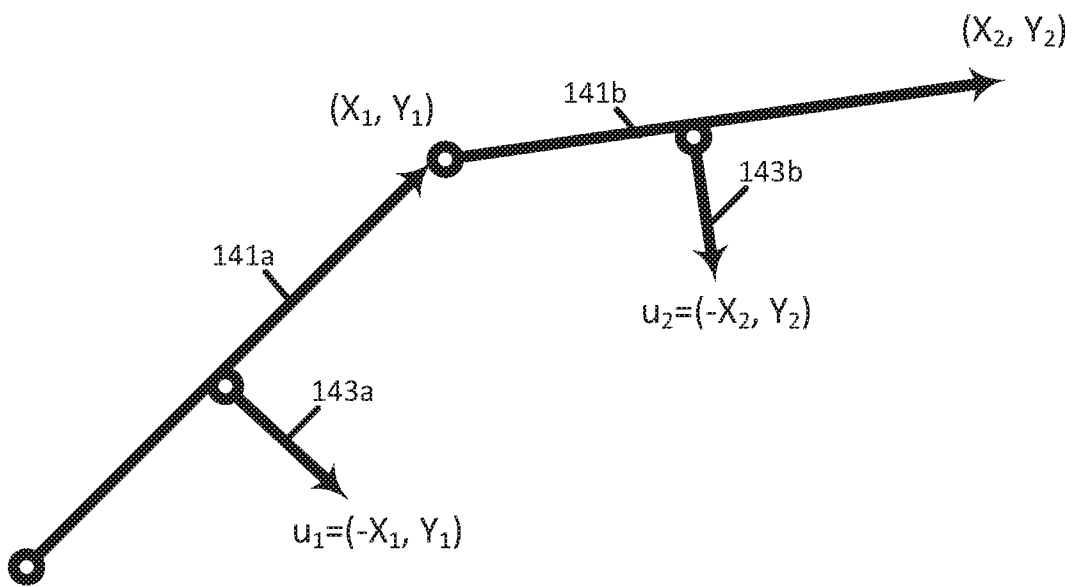

FIG. 3B

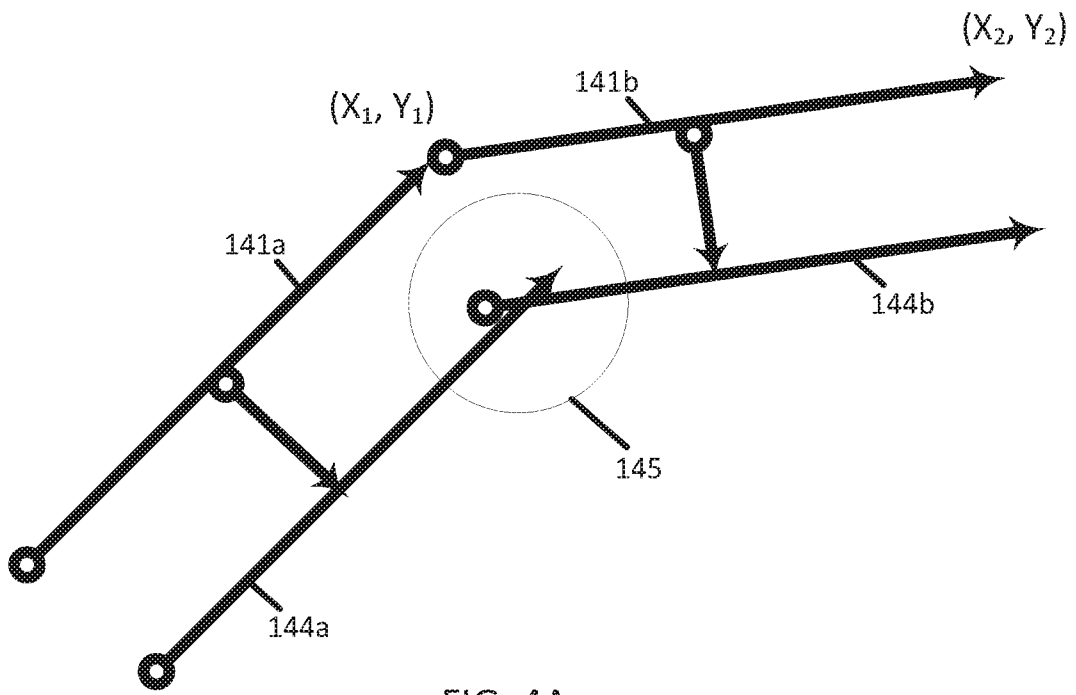

FIG. 4A

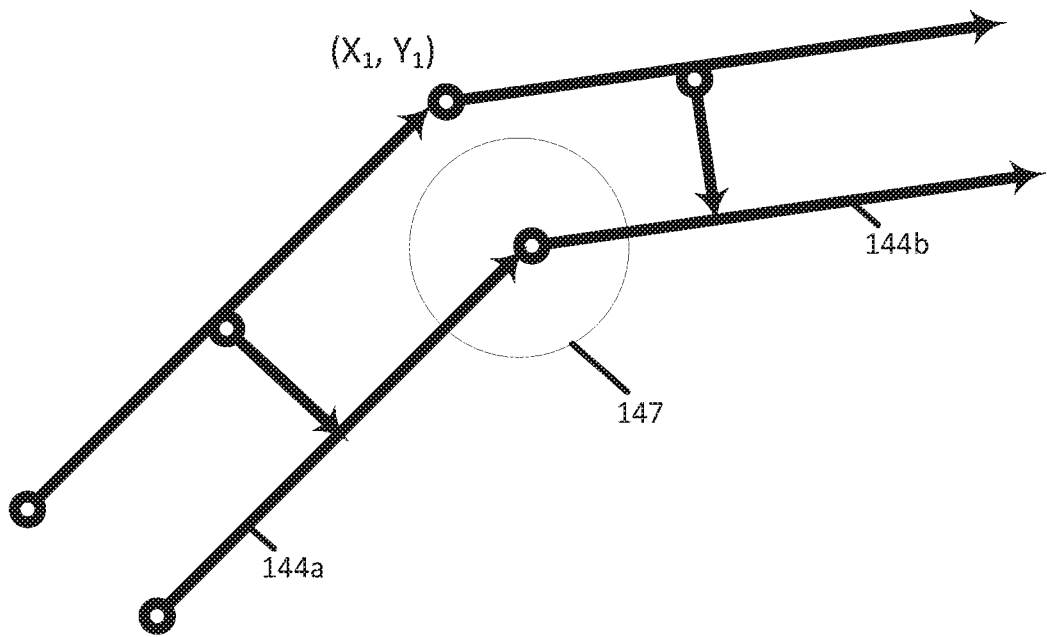

FIG. 4B

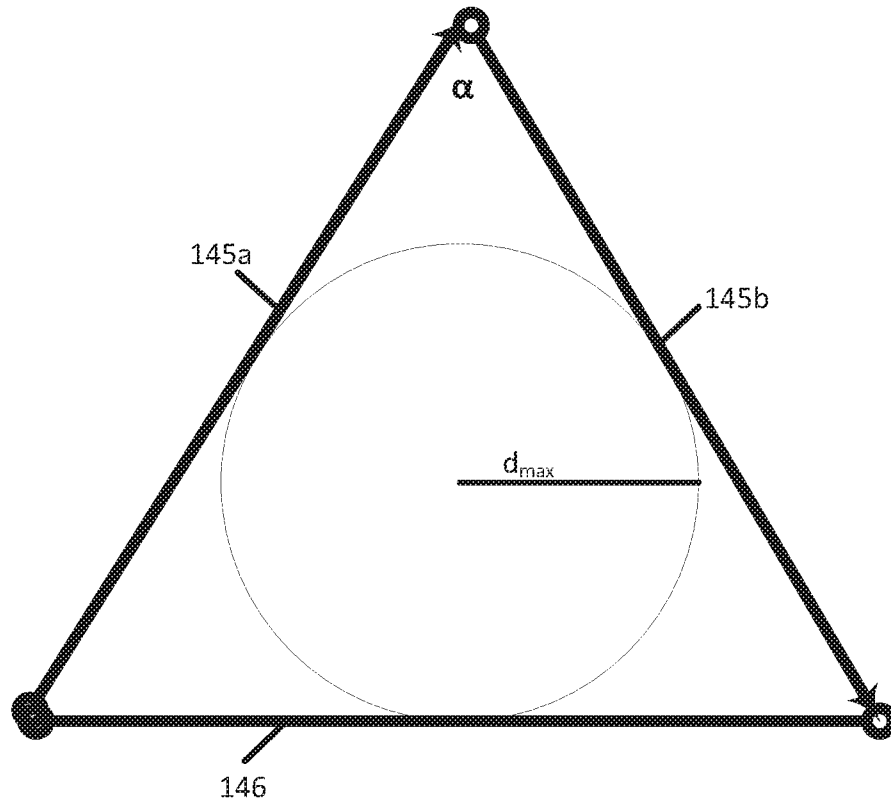

FIG. 5

150

FUNCTIONAL CLASS	ENVELOPE FACTOR
1	2.00
2	1.75
3	1.50
4	1.25
5	1.00

FIG. 6A

155

FUNCTIONAL CLASS	NUMBER OF LANES	ENVELOPE SIZE (microdegrees)
1	8	100
1	6	80
1	4	70
2	4	60
2	2	50
3	2	45
3	1	35

FIG. 6B

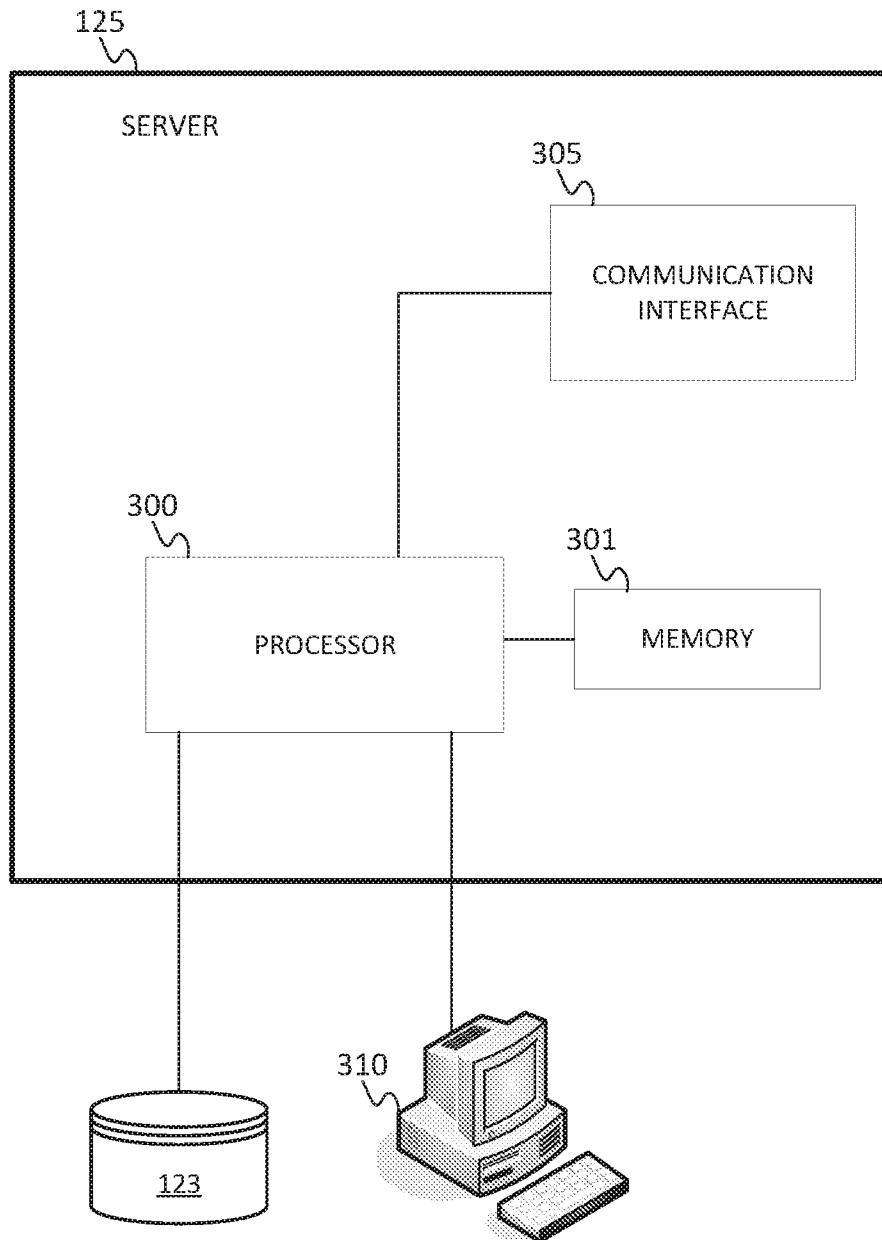

FIG. 7

8/10

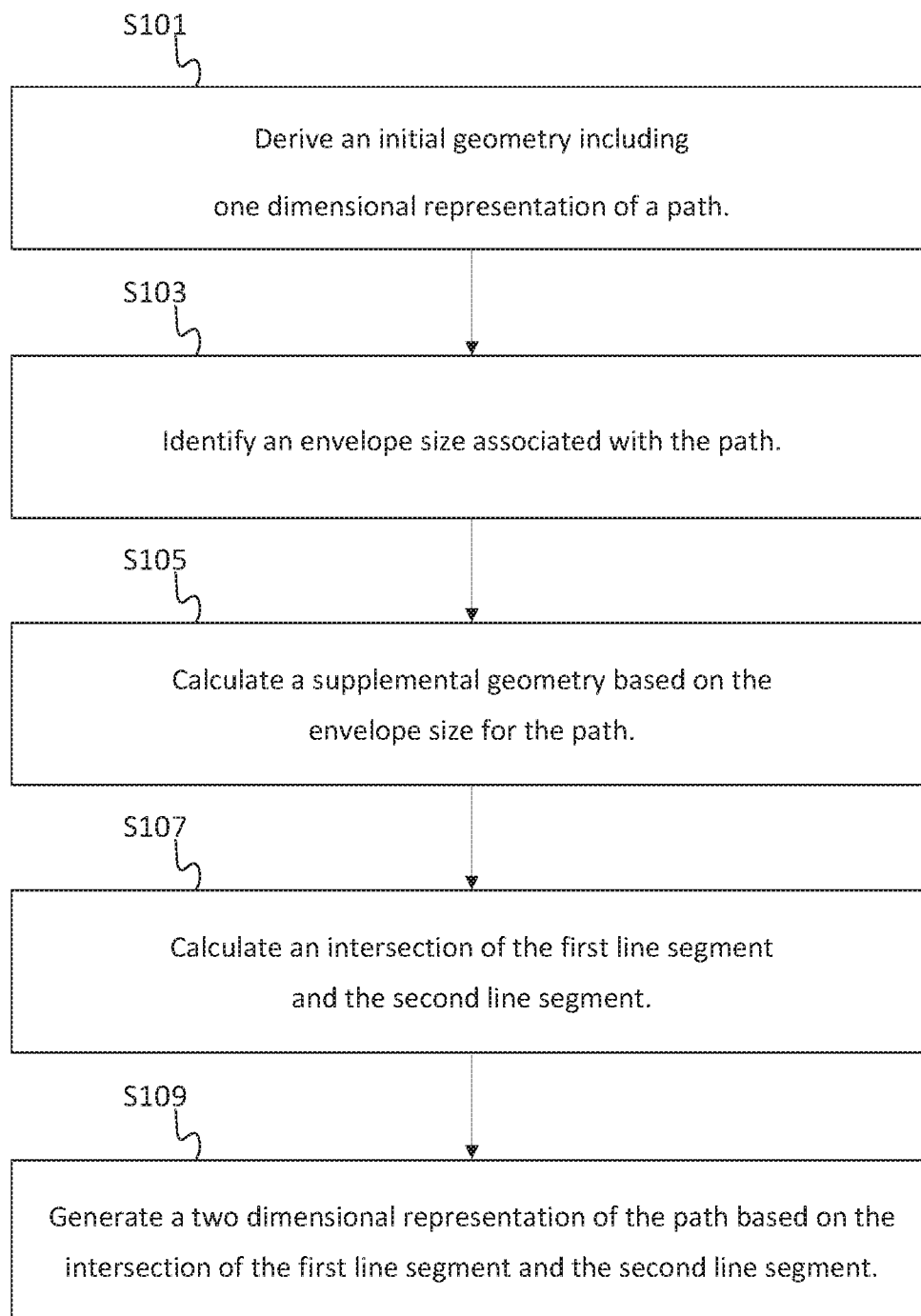

FIG. 8

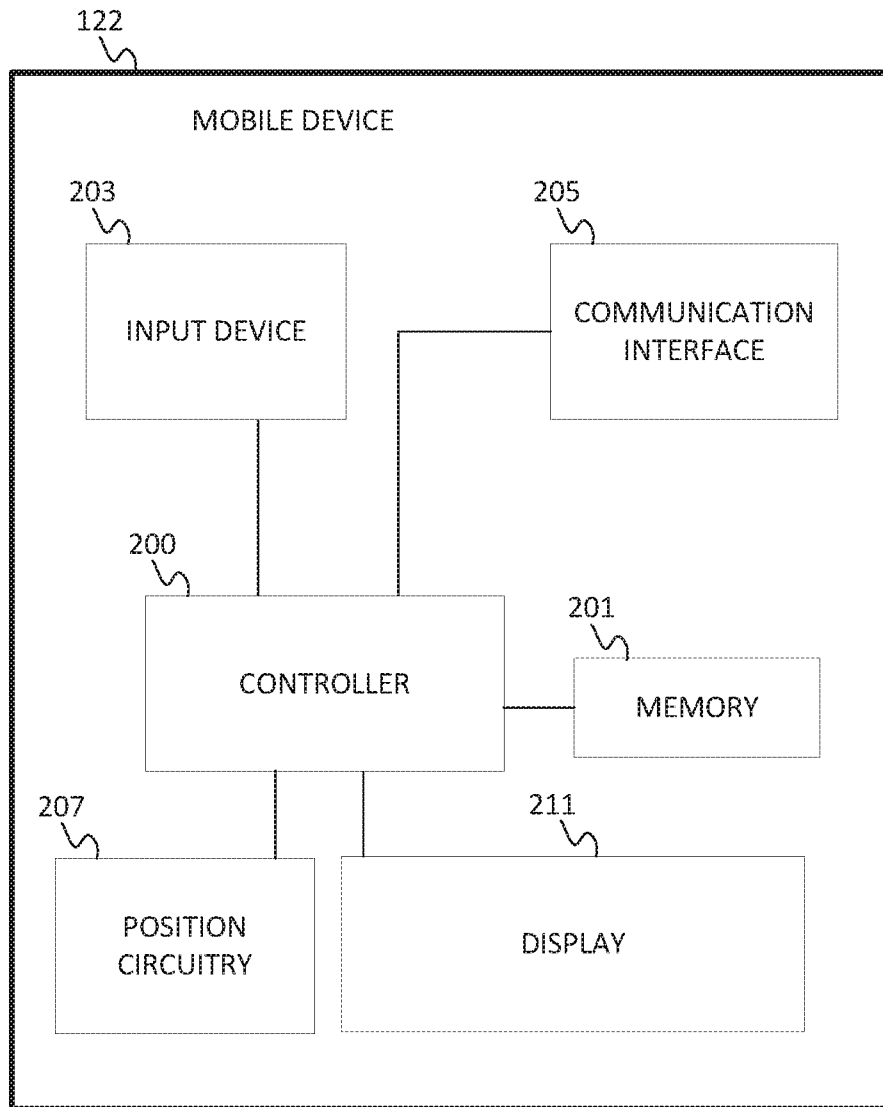

FIG. 9

10/10

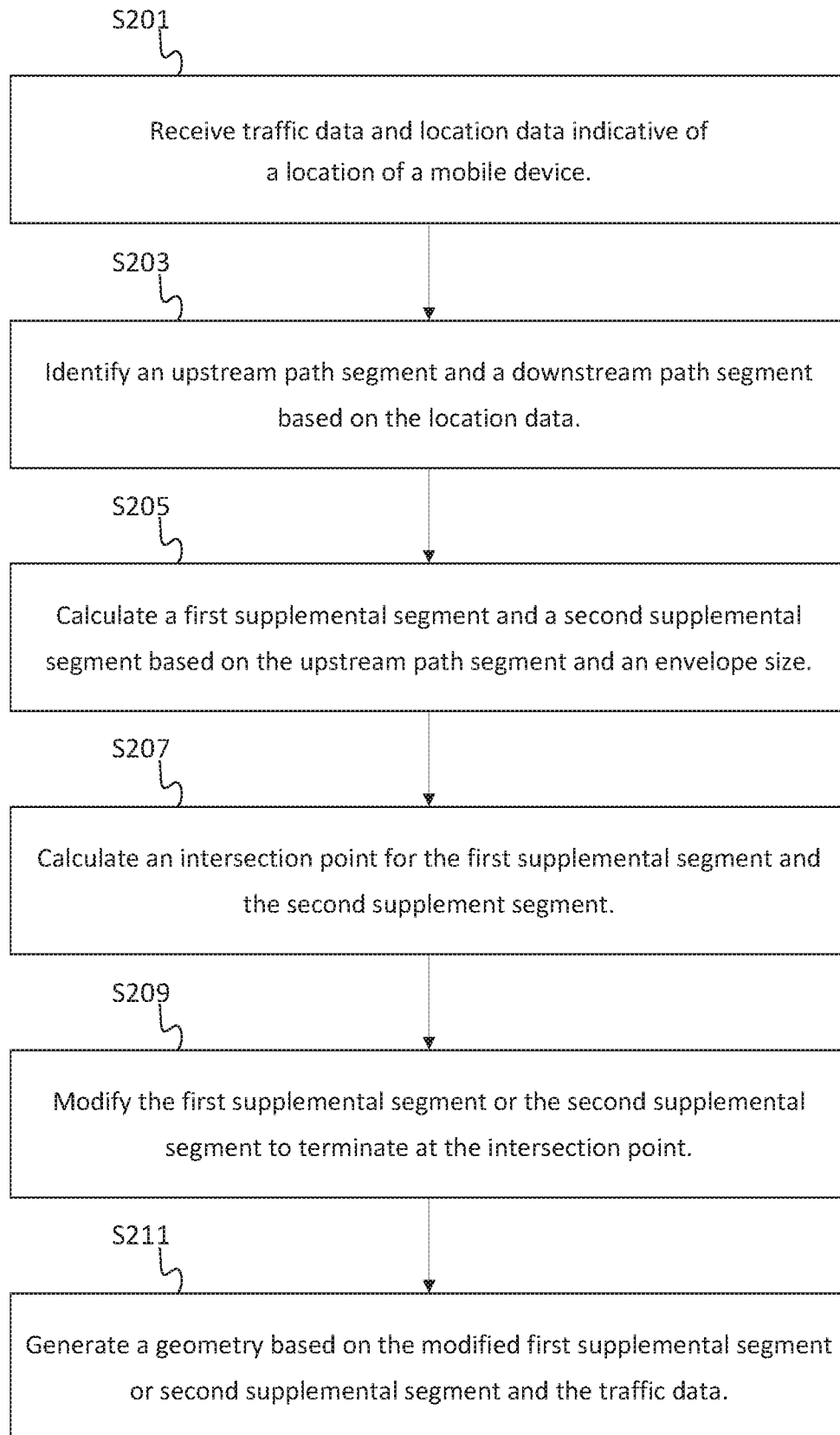

FIG. 10

INTERNATIONAL SEARCH REPORT

International application No
PCT/IB2015/052883

A. CLASSIFICATION OF SUBJECT MATTER INV. G01C21/32 G06T11/00 G09B29/10 ADD.		
According to International Patent Classification (IPC) or to both national classification and IPC		
B. FIELDS SEARCHED		
Minimum documentation searched (classification system followed by classification symbols) G01C G06T G09B G06F G08G		
Documentation searched other than minimum documentation to the extent that such documents are included in the fields searched		
Electronic data base consulted during the international search (name of data base and, where practicable, search terms used) EPO-Internal, WPI Data		
C. DOCUMENTS CONSIDERED TO BE RELEVANT		
Category*	Citation of document, with indication, where appropriate, of the relevant passages	Relevant to claim No.
X	US 2013/328861 A1 (ARIKAN OKAN [US] ET AL) 12 December 2013 (2013-12-12) paragraphs [0131] - [0141], [0171] - [0182]; figures 6,12,20 -----	1-9, 11-20
A	US 6 466 862 B1 (DEKOCK BRUCE W [US] ET AL) 15 October 2002 (2002-10-15) figures 6,8 -----	1-20
X	EP 0 579 451 A1 (SUMITOMO ELECTRIC INDUSTRIES [JP]) 19 January 1994 (1994-01-19) column 6, line 33 - column 7, line 29; figure 2 -----	1-17 18,20
<input type="checkbox"/> Further documents are listed in the continuation of Box C. <input checked="" type="checkbox"/> See patent family annex.		
* Special categories of cited documents :		
"A" document defining the general state of the art which is not considered to be of particular relevance "E" earlier application or patent but published on or after the international filing date "L" document which may throw doubts on priority claim(s) or which is cited to establish the publication date of another citation or other special reason (as specified) "O" document referring to an oral disclosure, use, exhibition or other means "P" document published prior to the international filing date but later than the priority date claimed		"T" later document published after the international filing date or priority date and not in conflict with the application but cited to understand the principle or theory underlying the invention "X" document of particular relevance; the claimed invention cannot be considered novel or cannot be considered to involve an inventive step when the document is taken alone "Y" document of particular relevance; the claimed invention cannot be considered to involve an inventive step when the document is combined with one or more other such documents, such combination being obvious to a person skilled in the art "&" document member of the same patent family
Date of the actual completion of the international search	Date of mailing of the international search report	
31 July 2015	11/08/2015	
Name and mailing address of the ISA/ European Patent Office, P.B. 5818 Patentlaan 2 NL - 2280 HV Rijswijk Tel. (+31-70) 340-2040, Fax: (+31-70) 340-3016	Authorized officer Gagin, Thibaut	

INTERNATIONAL SEARCH REPORT

Information on patent family members

International application No

PCT/IB2015/052883

Patent document cited in search report	Publication date	Patent family member(s)	Publication date	
US 2013328861	A1	12-12-2013	US 2013328861 A1	12-12-2013
			US 2013328883 A1	12-12-2013
			US 2013328915 A1	12-12-2013
			US 2013328916 A1	12-12-2013
			US 2013328924 A1	12-12-2013

US 6466862	B1	15-10-2002	US 6466862 B1	15-10-2002
			US 2002193938 A1	19-12-2002
			US 2003225516 A1	04-12-2003
			US 2004267440 A1	30-12-2004
			US 2005248469 A1	10-11-2005
			US 2006058941 A1	16-03-2006
			US 2008010002 A1	10-01-2008
			US 2008045197 A1	21-02-2008
			US 2008045242 A1	21-02-2008
			US 2009287404 A1	19-11-2009
			US 2010253544 A1	07-10-2010
			US 2011015853 A1	20-01-2011
			US 2015149070 A1	28-05-2015

EP 0579451	A1	19-01-1994	DE 69321302 D1	05-11-1998
			DE 69321302 T2	02-06-1999
			EP 0579451 A1	19-01-1994
			JP 2760253 B2	28-05-1998
			JP H0683937 A	25-03-1994
			US 5613055 A	18-03-1997
