

Oct. 31, 1950

T. O'D. LEGGE  
MANDIBULAR POSITIONER

2,528,153

Filed Oct. 29, 1947

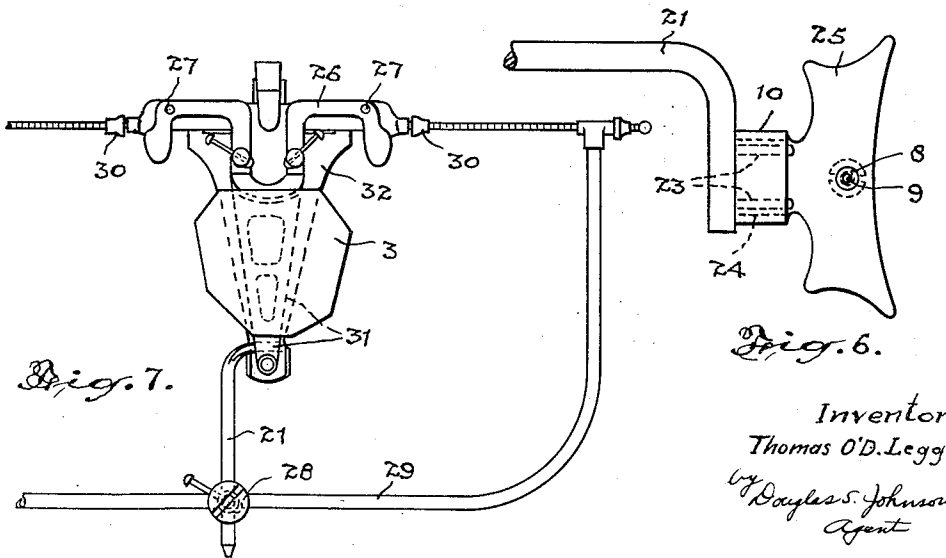
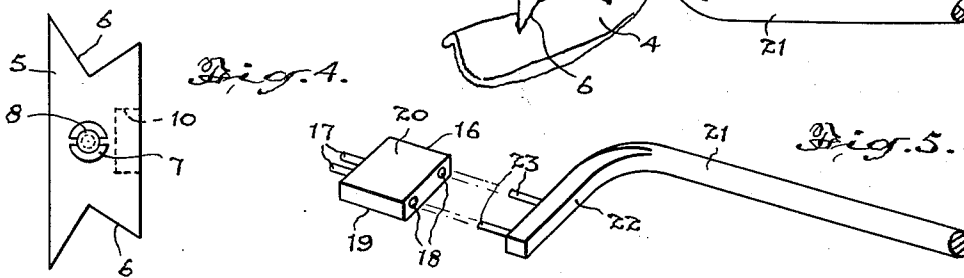
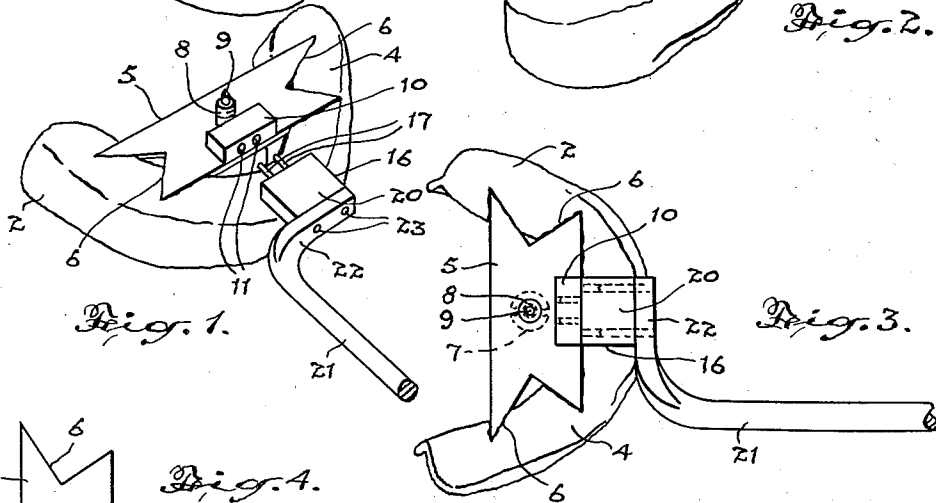
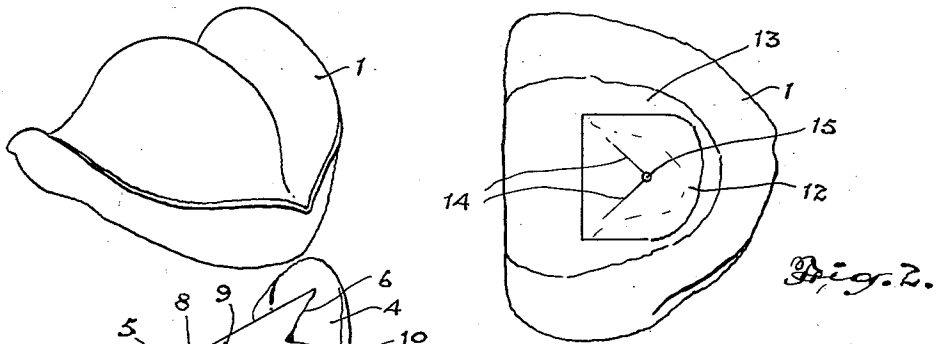

Inventor  
Thomas O'D. Legge  
by Douglas S. Johnson  
Agent

# UNITED STATES PATENT OFFICE

2,528,153

## MANDIBULAR POSITIONER

Thomas O'D. Legge, Sudbury, Ontario, Canada

Application October 29, 1947, Serial No. 782,782

5 Claims. (Cl. 32-19)

1

This application is a continuation-in-part of my earlier patent application Serial No. 618,007, filed September 22, 1945 and now abandoned.

This invention relates to dental instruments for use in the construction of dentures and the principal object of the invention is to provide a very simple and effective instrument which will be extremely easy to use and will enable the correct centric relationship of the mandible, or lower jaw, and the maxilla, or upper jaw, to be determined, and will enable the necessary measurements with a face bow to be quickly and accurately obtained while the centric relationship of the jaws is maintained to enable models of the jaws to be accurately positioned upon an articulator in the same position relative to its joints, that the natural ridges bear to the natural articulation.

A further and important object is to provide an instrument which, when not required for use with the face bow, may be conveniently utilized as a centric positioner to accurately determine the correct position or relationship of the mandible to the maxilla on the vertical and horizontal planes.

The principal feature of the invention consists in forming base plates or bite blocks to fit a patient's jaws, mounting a transversely extending plate on the lower base plate, providing means for locking said base plates from relative movement while in the patient's mouth to maintain the jaws in predetermined correct centric relation, providing a socket on said transversely extending plate, and providing a pin removably engaged in said socket and adapted when engaged therein to extend from the patient's mouth for co-operation with a face bow to permit accurate face bow readings to be obtained with the patient's jaws held in correct centric relation.

A further important feature consists in providing an attachment block to be interposed between and to removably interlock with the socket carried by the lower base plate and the pin with which the face bow co-operates, the block being arranged to extend over and engage the forward upper surface of the lower base plate and to provide an accurate bearing surface with which the upper base plate co-operates when the patient's jaws are closed but being readily removable when desired to permit the base plates to move into actual engagement.

A still further feature consists in forming the pin for co-operation with the face bow with a right angularly extending socket engaging head

2

whereby the pin when engaged in the socket carried by the lower base plate will extend from the patient's mouth in a plane substantially parallel to but offset from a plane bisecting a line between the patient's articulation joints.

Referring to the accompanying drawings, Figure 1 is a perspective view of the upper and lower base plates with the pin and block attachments being shown ready for insertion into the socket carried by the lower base plate.

Figure 2 is a plan view showing the underside of the upper base plate.

Figure 3 is a plan view of the lower base plate showing the attachment block with the pin secured thereto inserted in the base plate and socket member.

Figure 4 is a plan view of the socket-carrying plate for mounting on the lower base plate.

Figure 5 is a perspective view of the attachment block and the pin with the pin removed therefrom.

Figure 6 is a plan view of an alternative form of socket-carrying plate for attachment to the lower base plate with the pin attachment block dispensed with and showing the offset pin inserted directly into the socket.

Figure 7 is a plan view illustrating the use of my instrument in conjunction with an articulator and a face bow for properly locating models of the patient's jaws relative to the joints of the articulator corresponding to the relation the natural ridges bear to the natural articulation.

In the past various forms of intra-oral and extra-oral devices have been proposed to determine the correct centric relation of the jaws of a patient.

However, until the present there has been no instrument provided for co-operation with the centric relation position device to enable face bow readings to be quickly obtained while the jaws are held in centric relation.

The present invention has been accordingly devised to provide an arrangement whereby a face bow can be conveniently used in conjunction with a centric relation positioning device to obtain the desired readings necessary to position models of the patient's jaws in correct position on an articulator and to eliminate the necessity of cementing pins or other devices to the patient's base block or bite block to obtain the face bow readings.

With reference to the accompanying drawings, I provide an upper base plate 1 and a lower base plate 2, as shown in Figure 1, which are made to fit the upper and lower jaws respectively of a

3

patient to be fitted with a denture. The base plates 1 and 2 are in actual practice formed on models 3 of the patient's jaws and may be of a shellac or other suitable material.

Arranged on the upper surface of the lower base plate 2 is an impression compound 4 which serves as a bond to secure a plate 5 which extends transversely of the lower base plate and is preferably provided with notched ends 6 embedded in the impression compound.

Secured to the underside of the plate 5 is an internally threaded split sleeve or boss 7, and in the sleeve 7 is arranged a threaded pin 8 formed with a reduced extension or recording point 9 on its upper end.

Secured to the upper surface of the plate 5 forward of the pin 8 and midway between the plate ends 6 is a rectangular shaped block 10 provided with a pair of spaced holes 11 in its forward edge to form a socket member, the purpose of which will hereinafter appear.

As shown in Figure 2, a plastic disc 12 is supported centrally of the upper base plate by means of suitable plaster 13. When the base plates are fitted to the patient's jaws and the patient is instructed to move his jaws, the plastic disc 12 is adapted to be engaged by the recording point 9 of the pin 8 carried by the lower base plate and to record a tracing 14 of the jaw movement.

The configuration or tracing recorded on the disc 12 is known as the Gothic arch, and a hole 15 is provided in the disc at the apex of the arch, which represents the correct centric relationship of the jaws. This hole 15 is of sufficient size to admit the pin extension 9 which then serves as a lock to prevent relative movement of the base plate while fitting the patient's mouth holding the jaws in correct centric relation.

As illustrated in Figures 1, 3 and 5, a rectangular shaped block 16 is provided, the thickness and length of the block 16 corresponding to the socket block 10 mounted on the plate 5.

Extending from one of the longitudinal edges of the block 16 are spaced prongs 17 adapted to enter the holes 11 of the socket block 10, and arranged on the opposite edge of the block 16 are spaced socket holes 18. The block 16 when fitted to the socket block 10 rests with its flat under-surface 19 contacting the upper surface of the lower base plate 2, while the flat upper surface 20 of the attachment block 16 forms an accurate bearing surface with which the upper base plate 1 engages when the patient's jaws are closed.

The pin 21 for engagement with the removable attachment block 16 is formed of a length of rod having a right angularly turned end or head portion 22 which carries two spaced prongs 23 for engagement in the socket holes 18 of the block 16, the axis of the prongs 23 being parallel with the axis of the pin 21.

Thus with the prongs of the pins 21 inserted into the socket holes of the attachment block 16 and the prongs of the block 16 inserted into the holes of the block 10, the pins 21 extend forwardly of the base plate 2 with its axis parallel to but offset from a line bisecting the plate 5 and intersecting the centre of the centrally arranged pin 8 and block 10. Hence the pin 21 will be parallel to and offset from a plane bisecting a line between the patient's articulation joints when the base blocks are fitted to the patient's jaws.

In the plan view Figure 6 illustrating an alternative form of transverse plate 5, the block 10 is mounted on an extension 24 of the plate 25, and the underside of the plate extension 24 is

4

adapted to engage the forward upper surface of the base plate 2.

If desired the socket block 10 may be formed as an integral part of the plate 25.

In the arrangement illustrated in Figure 6, the attachment block 16 is dispensed with and the prongs 23 of the pin 21 engage directly in the holes 11 of the socket block 10.

In using my device to obtain measurements whereby the models 3 of the patient's jaws can be correctly positioned on the articulator 26 with the models bearing the same relation to the articulator joints 27 as do the natural articulations, a condition necessary for forming dentures of the desired accuracy, the base plates 1 and 2 commonly known as bite blocks are inserted into the patient's mouth and the centric relation of the jaws determined as described.

This procedure is conveniently carried out with the pin and the attachment block 16 removed.

In determining the centric relation of the jaws the pin 8 is adjusted for height so that when the patient closes his jaws and the pin 8 is engaged with the disc 12, the jaws are the normal distance apart.

With the jaws in correct centric position and the correct distance apart and with the tip of the pin 8 engaged in the hole 15 in the disc 12 secured to the upper base plate 1, the attachment block 16 is inserted into the socket block 10 and the prongs of the pin 21 are inserted into the attachment block 16. As explained, the axis of the pin 21 then extends parallel to a plane bisecting a line joining the points of natural articulation.

Next, the vice 28 of a face bow 29 is fitted to the outward end of the pin 21 and the pointers 30 of the face bow are moved in to engage the patient's face at the points where the condyles are located. In actual practice one of the face bow pointers is pushed to its fullest extent and locked. The other pointer is then pushed against the tissue and locked and the total number of scale markings read from the pointers is divided by two. The pointers are then set to the new reading and the face bow adjusted to the new reading and locked in position to the offset pin 21. The pointers 30 are then released and the face bow with the offset pin is removed. The base blocks 1 and 2 or bite blocks are then sealed together with plaster and removed from the mouth.

In utilizing the face bow pointer setting and the setting of the offset pin 21 in the face bow vice for locating the models 3 properly on the articulator, the upper model is placed in its base plate 1, the prongs of the offset pin 21 are returned to the socket holes 18 of the attachment block 16 and the pointers of the face bow are adjusted to the articulator according to the recorded registration. The upper model is then sealed in place with soft plaster to the upper arm 31 of the articulator. The face bow and pin 21 are then removed and the lower model is placed in its base plate 2 and sealed in place with soft plaster to the lower arm 32 of the articulator. The models 3 will then be in correct position relative to the articulator joint.

Since articulators and face bows form no actual part of my invention and are old, no further detailed description of same is deemed necessary.

It will be understood of course that where dentures are to be made without the use of a face bow and articulator the pins 21 can be quickly removed, together with the attachment block 16 from the socket block 10, or where the attachment block 16 is not used the pin 21 can be

5

removed directly from the socket 10, permitting the base plates 1 and 2 to be used solely as an intra-oral tracing device.

With the attachment block 16 removed the socket block 19 will not interfere with the closing of the jaws to bring the base plates or bite blocks into engagement but where an accurate bearing surface for spacing the base plates is required the block 16 can then be quickly positioned with its prongs 17 engaging in the holes 11 of the socket block 10 and the upper base plate or bite block closed to engage the flat upper block surface 20.

From the foregoing it will be appreciated that my instrument will be extremely convenient to use, the correct centric relation of the jaws being readily determined and the opposite ends 21 quickly attached to enable the face bow readings to be obtained.

In addition it will be appreciated that the socket-carrying plate 5, the attachment block 16 and the pin 21 can be readily made at relatively low cost and can be quickly attached to the desired base plate.

While I have shown and described the plate 5 as secured to the lower base plate 2, it will be understood of course that the arrangement could be reversed if desired and the plate 5 secured to the upper base plate.

What I claim as my invention is:

1. The combination with an upper and lower base plate fitting a patient's jaws, of a plate secured to and extending transversely of the lower base plate, an adjustable pin carried by said transversely extending plate, an opening in the upper base plate to receive said pin, a socket member removably supported in an accurately oriented position on the upper side of said transversely extending plate and lying substantially wholly within the dimensions of said base plates, and a removable offset pin formed with projection means removably engageable in said socket to extend from the mouth of a patient substantially parallel to but offset from the right bisector of a line joining the articulation joints of the patient's jaws to enable the relation of said plates and pin to be maintained in locating said plates with a face bow and an articulator.

2. A device as claimed in claim 1 in which the upper surface of said socket is flat to form an accurate bearing surface for the forward edge of the upper base plate when closed on the lower base plate to accurately locate the plane of the upper base plate with respect to the lower base plate.

3. The combination with an upper and lower base plate fitting a patient's jaws, of a plate secured to and extending transversely of the lower

6

base plate, means carried by said transversely extending plate for engaging the upper base plate to prevent relative movement therebetween, a socket arranged on the upper side of said transversely extending plate, said socket projecting above said transversely extending plate and having openings in the forward edge thereof, a flat removable block formed with prongs engaging in the openings in said socket, said block extending forwardly of said plate and having the underside thereof bearing on the upper surface of said lower base plate, and a pin for co-operation with a face bow, said pin being removably connectable with the forward edge of said block.

4. The combination with an upper and lower base plate fitting a patient's jaws and means for locking said base plate from relative movement with the jaws in centric relation, of socket means carried by one of said base plates, a flat block formed with projection means removably engaged in said socket lying parallel to and substantially wholly within the dimensions of said base plates and forming an accurate bearing surface to accurately space said base plates, and a pin for co-operation with a face bow removably connected with said block.

5. The combination with an upper base plate and a lower base plate fitting a patient's upper and lower jaws respectively, of adjustable pin means for locking said plates from relative movement with the jaws in predetermined centric relation, a flat socket formed with a pair of spaced openings carried by one of said plates and lying substantially wholly within the dimensions of said plates and forming an accurate bearing surface to accurately space said plates, and a pin for co-operation with a face bow having an offset portion formed with a pair of pin projections aligned with and removably engaged in said openings, said pin being adapted when the jaws are held in centric relation to extend forwardly thereof substantially parallel to and offset from the right bisector of a line joining the articulation joints of the jaws to enable the relation of said plates and pin to be maintained in locating said plates with a face bow in an articulator.

THOMAS O'D. LEGGE.

REFERENCES CITED

The following references are of record in the file of this patent:

UNITED STATES PATENTS

Number	Name	Date
1,052,806	Evans -----	Feb. 11, 1913
1,764,115	Mulcahy -----	June 17, 1930
1,864,804	Clark -----	June 28, 1932