



(11) **EP 1 559 907 B2**

(12) **NEW EUROPEAN PATENT SPECIFICATION**  
After opposition procedure

(45) Date of publication and mention of the opposition decision:  
**11.08.2010 Bulletin 2010/32**

(51) Int Cl.: **F02M 61/12 (2006.01) F02M 61/16 (2006.01)**

(45) Mention of the grant of the patent:  
**15.11.2006 Bulletin 2006/46**

(21) Application number: **04001803.8**

(22) Date of filing: **28.01.2004**

(54) **Fluid injector with means to prevent rotation of the valve needle**

Einspritzventil mit Mittel, um Ventilnadelrotation zu verhindern

Soupape d'injection avec moyens pour éviter la rotation de l'aiguille

(84) Designated Contracting States:  
**DE FR GB IT**

(43) Date of publication of application:  
**03.08.2005 Bulletin 2005/31**

(73) Proprietor: **Continental Automotive Italy S.p.A.**  
**56040 Fauglia (PI) (IT)**

(72) Inventors:  
• **D'Arrigo, Angelo**  
**57013 Rosignano Solvay (IT)**  
• **Mariani, Giuseppe**  
**57128 Livorno (IT)**

(74) Representative: **Bonn, Roman Klemens et al**  
**Continental Automotive GmbH**  
**Patente und Lizenzen**  
**Postfach 22 16 39**  
**80506 München (DE)**

(56) References cited:  
**EP-A- 0 512 598 EP-A- 1 041 274**  
**GB-A- 1 005 354 GB-A- 1 329 525**  
**JP-A- 2002 089 397 US-A- 4 382 554**  
**US-A1- 2002 100 822 US-B1- 6 199 539**

**EP 1 559 907 B2**

## Description

**[0001]** The invention relates to a valve body, a fluid injector and a method for manufacturing the fluid injector. The valve body comprises a cartridge with a recess, that forms an injection nozzle on one end, and comprises a needle, which is arranged in the recess, and closes the injection nozzle, if it rests with its seat area on a needle seat of the cartridge.

**[0002]** Fluid injectors, in particular fuel injectors for diesel or gasoline internal combustion engines, comprise a housing, an actuator unit and a valve body. The valve body comprises a needle that opens or closes a nozzle and in that way controls the injection of fuel. In an increasing number of applications actuator units with a piezoelectric actuator are used. They have the advantage of having a very fast response time to actuating signals and enable like that multiple injections into a cylinder of the internal combustion engine during one working cycle of the cylinder. In order to improve the spray characteristics of the fluid injector the fluid pressure is increased. In current gasoline internal combustion engines the fluid injectors are supplied with fuel which has a pressure of up to 200 bars.

**[0003]** WO 03/016707 A1 discloses a fluid injector with a connector to a fuel supply, a housing, an actuator unit, and a valve body. The housing is double tubed and has a recess, which takes up the actuator unit. The actuator unit comprises a piezoelectric actuator, which acts on the needle. Between the walls of the double tube-shaped housing the fuel is led from the connector to a fuel inlet of the valve body. The valve body has a housing part with a recess, that takes up a needle. Depending on the position of the needle a nozzle is opened or closed and respectively fuel is injected or not.

**[0004]** EP 0 512 598 A1 discloses a fuel injection nozzle with a nozzle body, comprising a fuel passage and a valve seat at one of its ends, and a poppet valve arranged in the fuel passage including a head, that cooperates with the valve seat of the nozzle body, and an elongated valve stem. The nozzle body is provided with an axially extending locating bore placed off-center from the axis of the nozzle body. In the side of the valve stem a positioning slot is formed. A locating ball is arranged in the aligned locating bore of the nozzle body and the positioning slot of the valve stem that allows for axial movement of the valve stem in the nozzle body and prevents rotation of the valve stem relative to the nozzle body.

**[0005]** Increasingly strict legislation concerning emissions of internal combustion engines, where a valve body or a fluid injector with valve body is arranged, make it necessary to put a lot of effort in measures, that reduce the emissions. Very important for the prevention of exhaust emissions is, that fluid injectors used for the internal combustion engine have a defined and constant spray characteristic.

**[0006]** In order to achieve such a defined and constant spray characteristic it is known to provide the areas of the needle and the cartridge adjacent to the injection nozzle with a very precise finish by a grinding process, for example by lapping. By doing this the buildup of coking is prevented and that way the constant spray characteristic can be ensured.

**[0007]** The object of the invention is to create a valve body, a fluid injector and a method for manufacturing the fluid injector, which is simple and enables a precise manufacture of the valve body or respectively the fluid injector.

**[0008]** The object is achieved by the features of the independent claims. Advantageous embodiments of the invention are given in the subclaims.

**[0009]** The invention concerning the valve body is distinguished by a valve body with a cartridge with a recess, that forms an injection nozzle on one end and with a needle, that is arranged in the recess and closes the injection nozzle, if it rests with its seat area on a needle seat of the cartridge. The cartridge comprises a further recess or a raised area. In addition to that the valve body is provided with a ring-shaped holding element and with a recess or a raised area in the needle. The further recess or raised area in the cartridge, the holding element and the recess or raised area in the needle are formed and arranged in a way, that they cooperate to fix the needle in its rotational position relative to the cartridge. In that way the grinding of the areas of the needle and the cartridge facing outwards from the valve body and being located adjacent to the injection nozzle can be done without much effort as the needle cannot change its rotational position relative to the cartridge. During the operation of the valve body the needle is fixed in a simple way in its rotational position and that way the areas adjacent to the injection nozzle, which have been grinded during the manufacturing process, stay aligned, which prevents effectively the buildup of coking. In addition to that the needle is prevented from falling out of the cartridge during the assembly process, if the further recess or raised area in the cartridge, the holding element and the recess or raised area in the needle are suitably formed. The further recess or raised area in the cartridge is formed in such a way that the holding element fixes the needle at an end of the cartridge away from the injection nozzle.

**[0010]** The holding element is ring-shaped. A ring-shaped holding element does not necessarily have to be a full ring, it may also be a section of a ring or a ring comprising a slot. Such ring-shaped holding elements are widely and cheaply available.

**[0011]** In an advantageous embodiment of the valve body the holding element is arranged further away from the injection nozzle than a fluid inlet in the cartridge. This has the advantage, that the holding element does not interfere with the fluid flowing towards the injection nozzle.

**[0012]** In combination with the holding element being arranged further away from the injection nozzle than a fluid inlet the ring-shaped holding element dampens fluid pressure pulsations, which relieves respective parts located even further away from the injection nozzle than the holding element.

**[0013]** In a further advantageous embodiment of the valve body the recess in the needle is a blind hole. This has the advantage, that a blind hole is simple to manufacture and efficiently ensures, in cooperation with the holding element, that the needle cannot fall out.

**[0014]** In a further advantageous embodiment of the valve body the recess or raised area in the needle is formed as a flattening of a section of the cross-section of the needle. This has the advantage, that it is simple to manufacture.

**[0015]** In a further advantageous embodiment of the valve body, the recess or raised area in the cartridge is formed in such a way, that the holding element fixes the needle in the area of an end of the cartridge away from the injection nozzle. In this advantageous embodiment of the valve body the holding element can simply be, for example, axially pushed on the cartridge and there is no need for a passage through the cartridge for the holding element, which decreases the costs for manufacturing the device.

**[0016]** A fluid injector with a housing, an actuator unit and the valve body has the same advantages as the valve body itself.

**[0017]** The method for manufacturing the fluid injector is distinguished by the following steps. The needle is inserted in the cartridge. After that the needle seat of the cartridge and the seat area of the needle are grinded. This is preferably achieved by a lapping process, where the needle and the cartridge are rotated relatively to each other. After that the holding element is inserted and in that way the needle is fixed in its position relative to the cartridge for the next steps. Then the area of the needle and cartridge facing outwards from the injection nozzle and being adjacent to the injection nozzle are being grinded together. By this the areas are brought into very precise alignment to each other, which prevents buildup of coking during the operation of the valve body. After that the valve body is assembled with the housing. It may, for example, be fixed to the housing by welding. During the grinding process of the two areas of the needle and the cartridge it is not necessary to fix the rotational position of the needle by a special tool. It is advantageous to keep the holding element inside the valve body in the assembled fluid injector.

**[0018]** Exemplary embodiments of the invention are explained in the following with the aid of schematic drawings. These are as follows:

Figure 1                    a fluid injector,  
 Figure 2                    a valve body,  
 Figure 3                    a cartridge and a needle of the valve body in an disassembled way,  
 Figure 4                    a second embodiment of the valve body in an axial section,  
 Figure 5                    the holding element for the valve body according to Figure 4, and  
 Figures 6A, B, C, D        different cross-sections of the needle in the area of the recess or the raised area of the needle.

**[0019]** Elements of the same design and function that occur in different illustrations are identified by the same reference character.

**[0020]** A fluid injector, that is used as a fuel injector for an internal combustion engine, comprises a housing 1 (Figure 1), a valve body 2, an actuator unit 3 and a fuel connector 4. The fuel connector 4 is designed to be connected to a high pressure fuel chamber of the internal combustion engine, where fuel is stored under high pressure, for example under the pressure of about 200 Bar.

**[0021]** The housing 1 is preferably formed out of a double-tubed housing. In the space between the walls of the double-tubed housing the fuel is led from the fuel connector to a fuel inlet 214 of the valve body 2.

**[0022]** The valve body 2 comprises a cartridge 21, which is permanently fixed to the housing 1 at one of its free ends, preferably by welding, especially laser-welding. The cartridge 21 comprises a recess 211 (Figure 2) which forms at one of its ends an injection nozzle 213 and which takes in a needle 22.

**[0023]** A spring rest 24 is connected to the needle 22. A return spring 25 rests on the spring rest 24 and pretensions the needle 22 in a direction away from the injection nozzle 213. In that way the needle 22 closes the injection nozzle 213, if no further external forces act on the needle 22.

**[0024]** The fuel is led from the fuel inlet 214 in the space between the needle 22 and the wall of the recess 213 of the cartridge 21 to the injection nozzle 213. The needle 22 further comprises a guided zone 221, by which the needle 22 is guided within the recess 213.

**[0025]** In the position where the needle 22 closes the injection nozzle 213 the needle 22 rests with its seat area 224 on a needle seat 215 of the cartridge 21. The needle seat 215 and the seat area 224 are conically shaped in a preferred embodiment. This enables to set a desired spray angle.

**[0026]** Areas of the needle 22 and the cartridge 21 facing outwards from the injection nozzle 213 and being adjacent to the injection nozzle 213 are in a preferred embodiment conically shaped and are named in the following conically-shaped area 216 of the cartridge 21 and conically-shaped area 222 of the needle 22. These two conically-shaped areas 216 and 222 need to be precisely aligned in order to prevent the buildup of coking, which decreases the spray quality of the fuel injector. In order to achieve such a precise alignment, the conically-shaped areas 216 and 222 are grinded together which is described in detail below. The recess 211 is called in the following first recess 211.

[0027] The needle 22 comprises a recess 226. The recess 226 in the needle 22 is formed as a flattening of a section of the cross-section of the needle 22 (Figure 3). The recess 226 of the needle 22 has an axial length, that ensures, that the needle 22 can be axially moved by the actuator unit 3 and the return spring 25 as intended.

[0028] Figure 3 shows a first step of a manufacturing process for an embodiment of the fluid injector. The cartridge 21 has a second recess 217'. The second recess 217' is formed at an end of the cartridge 21, which is located in the area of the second free end of the first recess 211 with the first free end of the first recess 211 being the injection nozzle 213. In the manufacturing step shown in Figure 3 the needle 22 is inserted into the first recess 211. After that the needle seat 215 of the cartridge 21 and the seat area 224 of the needle 21 are grinded. This grinding process preferably includes a lapping process. For the lapping process a paste or fluid is used which contains the cutting material. During the lapping process the needle 22 and the cartridge 21 are rotated relatively to each other. By this a very precise finish of the needle seat 215 and the seat area 224 is achieved.

[0029] In the next manufacturing step (Figure 4) the holding element, which is a ring-shaped element 28 is inserted axially as shown by the arrows of Figure 4. The ring-shaped element 28 (Figure 5) is preferably generally ring-shaped but has a slot which increases flexibility of the ring-shaped element 28 and enables it to be used as a clip element, which is clipped into the recess 226 of the needle 22 and is pushed into the second recess 217'. It has contours that match the contour of the second recess 217' of the cartridge 21 and the contour of the recess 226 of the needle 22. In its assembled state the ring-shaped element 28 fills out a great part of the space between the needle 22 and the wall of the first recess 211 of the cartridge 21. In that way the ring-shaped element 28 has on one hand the function to prevent a rotational movement of the needle 22 relative to the cartridge 21 and on the other hand it dampens effectively pressure waves, which travel along the first recess from the injection nozzle 213 towards the ring-shaped element. This dampening effect relieves parts located even further away from the injection nozzle like a bellow or the actuator unit 3.

[0030] After the ring-shaped element 28 is inserted in the recess 226 of the needle 22 and the second recess 217' of the cartridge 21 the conically-shaped areas 216, 222 are grinded together in order to get them precisely aligned. This grinding process preferably includes a honing process and/or a lapping process. In the honing process the grinding wheel makes, for example, an oscillatory movement, oscillating between the needle 22 and the cartridge 21. At the same time the needle 22 and the cartridge 21 are turned around their axes. The grinding process may further include a lapping process. After having finished the grinding process the conically-shaped areas 216, 222 precisely match each other.

[0031] After the valve body is fully assembled it is preferably welded to the housing 1, the holding element may be kept in the valve body or may also be taken out. Preferably it is left in the valve body, which then ensures during the operation of the injection valve, that there is no rotational movement between the needle 22 and the cartridge 21.

[0032] Figure 6A shows an embodiment of the needle, which is simple to manufacture and ensures in cooperation with the holding element, that the needle 22 is tightly fixed in its rotational position relative to the cartridge 21. In another embodiment of the needle 22 (Figure 6B) the recess 228 is formed as a sector. In a further embodiment of the needle 22 the recess 229 is formed in a sinusoidal shape. In another embodiment of the needle 22 there is a raised area 229A. The holding elements, that cooperate with the different forms of the recess 227, 228, 229 or the raised area 229A are formed respectively to enable a rotational fixation of the position of the needle 22. Instead of having the second recess 217' there may also be a raised area which cooperates with the holding element.

## Claims

1. Valve body with a cartridge (21) with a recess (211), that forms an injection nozzle (213) on one end and with a needle (22), that is arranged in the recess (211) and closes the injection nozzle (213) if it rests with its seat area (224) on a needle seat (215) of the cartridge (21),
  - with a further recess (217, 217') or raised area in the cartridge (21),
  - with a holding element being a ring-shaped element (28) and
  - with a recess (226, 227, 228, 229) or a raised area (229A) in the needle (22),
  - with the further recess (217, 217') or raised area in the cartridge (21), the holding element and the recess (226, 227, 228, 229) or raised area (229A) in the needle (22) being formed and arranged in a way, that they cooperate to fix the needle (22) in its rotational position relative to the cartridge,
  - with the further recess (217, 217') or raised area in the cartridge (21) being formed in such a way that the holding element fixes the needle (22) at an end of the cartridge (21) away from the injection nozzle (213).
2. Valve body in accordance with claim 1, **characterized in that** the holding element is arranged further away from the injection nozzle than a fluid inlet.
3. Valve body in accordance with one of the preceding claims,

characterized in that the recess (226, 227, 228, 229) in the needle (22) is a blind hole.

4. Valve body in accordance with claims 1 or 2,  
characterized in that the recess (226, 227, 228, 229) or raised area (229A) in the needle is formed as a flattening  
of a section of the cross-section of the needle (22).
5. Fluid injector with a housing (1), an actuator unit (3) and a valve body (2) in accordance with one of the preceding  
claims.
6. Method for manufacturing an injector in accordance with claim 5 with the following steps:
- inserting the needle (22) in the cartridge (21),
  - grinding the needle seat (215) and the seat area (224) of the needle (22),
  - inserting the holding element,
  - grinding the area of the needle (22) and the cartridge (21) facing outwards from the injection nozzle (213) and  
being adjacent to the injection nozzle (213), and
  - assembling the valve body (2) with the housing (1).

## Patentansprüche

1. Ventilkörper mit einer Kartusche (21) mit einer Ausnehmung (211), die eine Einspritzdüse (213) an einem Ende  
bildet, und mit einer Nadel (22), die in der Ausnehmung (211) angeordnet ist und die Einspritzdüse (213) schließt,  
wenn sie mit ihrer Sitzfläche (224) auf einem Nadelsitz (215) der Kartusche (21) ruht,
- mit einer weiteren Ausnehmung (217, 217') oder einem erhabenen Bereich in der Kartusche (21),
  - mit einem Halteelement, das ein ringförmiges Element (28) ist, und
  - mit einer Ausnehmung (226, 227, 228, 229) oder einem erhabenen Bereich (229A) in der Nadel (22),
  - wobei die weitere Ausnehmung (217, 217') oder der erhabene Bereich in der Kartusche (21), das Halteelement  
und die Ausnehmung (226, 227, 228, 229) oder der erhabene Bereich (229A) in der Nadel (22) in einer Weise  
geformt und angeordnet sind, dass sie zur Fixierung der Nadel (22) in ihrer Drehlage relativ zur Kartusche  
zusammenwirken, während
  - die weitere Ausnehmung (217, 217') oder der erhabene Bereich in der Kartusche (21) so ausgebildet ist, dass  
das Halteelement die Nadel (22) an einem Ende der Kartusche (21) von der Einspritzdüse (213) weg fixiert.
2. Ventilkörper nach Anspruch 1, **dadurch gekennzeichnet, dass** das Halteelement von der Einspritzdüse weiter  
weg angeordnet ist als ein Strömungsmiteleinlass.
3. Ventilkörper nach einem der vorangehenden Ansprüche, **dadurch gekennzeichnet, dass** die Ausnehmung (226,  
227, 228, 229) in der Nadel (22) ein Sackloch ist.
4. Ventilkörper nach Anspruch 1 oder 2, **dadurch gekennzeichnet, dass** die Ausnehmung (226, 227, 228, 229) oder  
der erhabene Bereich (229A) in der Nadel als Abflachung eines Abschnittes des Querschnittes der Nadel (22)  
ausgebildet ist.
5. Strömungsmiteleinstritzvorrichtung mit einem Gehäuse (1), einer Betätigungseinheit (3) und einem Ventilkörper  
(2) nach einem der vorangehenden Ansprüche.
6. Verfahren zur Herstellung einer Einspritzvorrichtung gemäß Anspruch 5 mit den folgenden Schritten:
- Einsetzen der Nadel (22) in die Kartusche (21),
  - Schleifen des Nadelsitzes (215) und der Sitzfläche (224) der Nadel (22),
  - Einsetzen des Halteelementes,
  - Schleifen des Bereiches der Nadel (22) und der Kartusche (21), die von der Einspritzdüse (213) nach außen  
weisen und benachbart zur Einspritzdüse (213) angeordnet sind, und
  - Zusammenbauen des Ventilkörpers (2) mit dem Gehäuse (1).

**Revendications**

- 5 1. Corps de soupape comportant une cartouche (21) munie d'une dépression (211), qui forme une buse d'injection (213) sur une extrémité, et avec une aiguille (22), qui est agencée dans le retrait (211) et ferme la buse d'injection (213) lorsqu'elle repose avec sa zone de siège (224) sur un siège d'aiguille (215) de la cartouche (21), comprenant Une dépression supplémentaire (217, 217') ou une zone surélevée dans la cartouche (21), un élément de maintien étant un élément de maintien est un élément en forme de bague (28), et une dépression (226, 227, 228, 229) ou une zone surélevée (229A) dans l'aiguille (22), la dépression supplémentaire (217, 217') ou la zone surélevée dans la cartouche (21), l'élément de maintien et la 10 dépression (226, 227, 228, 229) ou la zone surélevée (229A) dans l'aiguille (22) étant formés et agencés de façon à coopérer pour fixer l'aiguille (22) dans sa position de rotation par rapport à la cartouche, l'autre dépression (217, 217') ou zone surélevée dans la cartouche (21) étant formé de sorte que l'élément de maintien fixe l'aiguille (22) à une extrémité de la cartouche (21) à distance de la buse d'injection (213).
- 15 2. Corps de soupape selon la revendication 1, **caractérisé en ce que** l'élément de maintien est agencé plus loin de la buse d'injection qu'une entrée de fluide.
3. Corps de soupape selon l'une des revendications précédentes, **caractérisé en ce que** la dépression (226, 227, 228, 229) dans l'aiguille (22) est un trou borgne. 20
4. Corps de soupape selon les revendications 1 ou 2, **caractérisé en ce que** la dépression (226, 227, 228, 229) ou la zone surélevée (229A) dans l'aiguille est formé comme un aplanissement d'une section de la section transversale de l'aiguille (22).
- 25 5. Injecteur de fluide comportant un boîtier (1), une unité d'actionnement (3) et un corps de soupape (2) selon l'une des revendications précédentes.
6. Procédé pour fabriquer un injecteur selon la revendication 5 comprenant les étapes suivantes consistant à :
- 30 insérer l'aiguille (22) dans la cartouche (21),  
meuler le siège d'aiguille (215) et la zone de siège (224) de l'aiguille (22),  
insérer l'élément de maintien,  
meuler la zone de l'aiguille (22) et de la cartouche (21) faisant face vers l'extérieur depuis la buse d'injection (213) et étant adjacente à la buse d'injection (213), et  
35 assembler le corps de soupape (2) avec le boîtier (1).

40

45

50

55

FIG 1

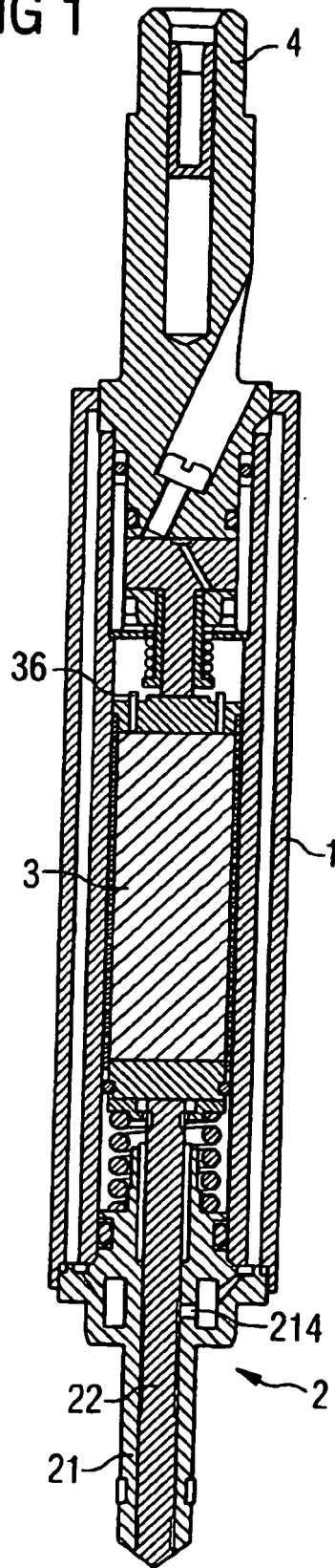

FIG 2

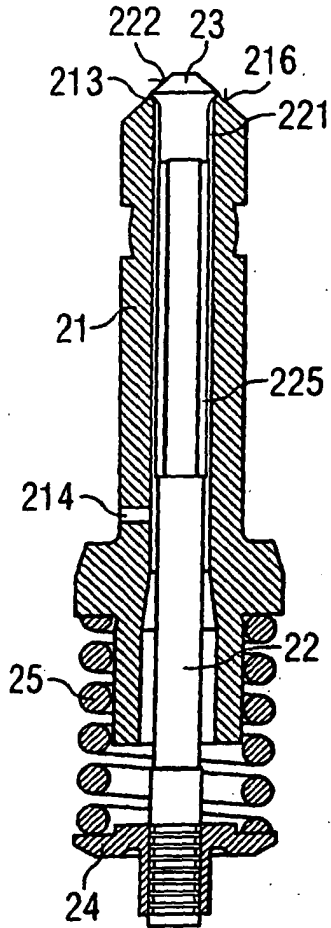
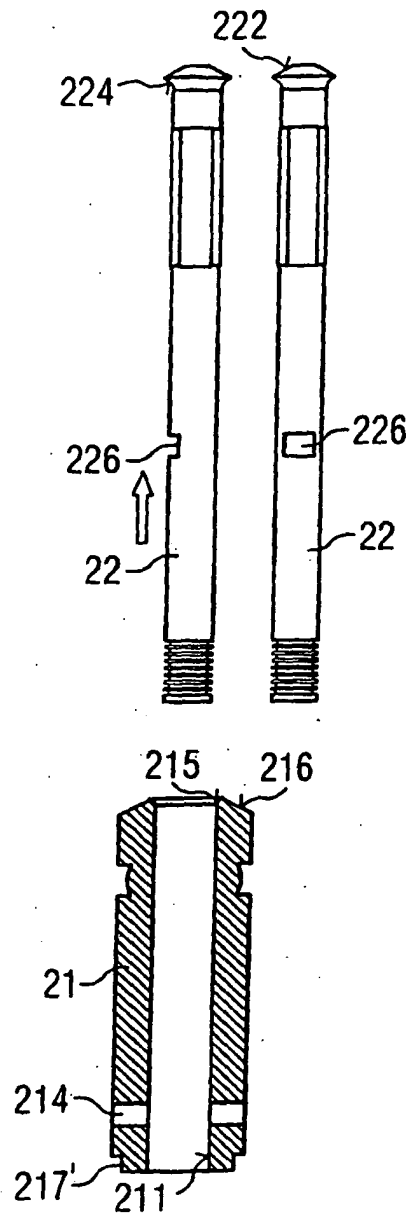
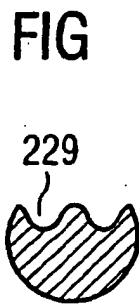
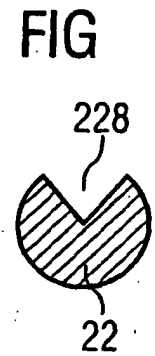
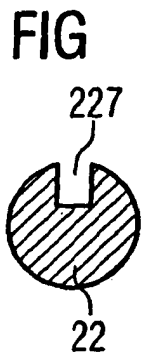
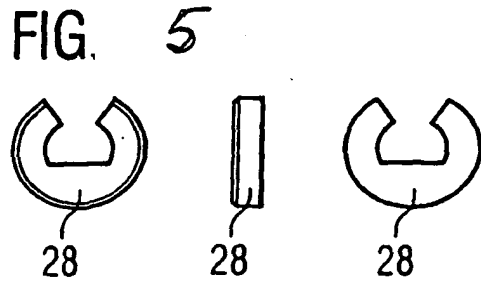
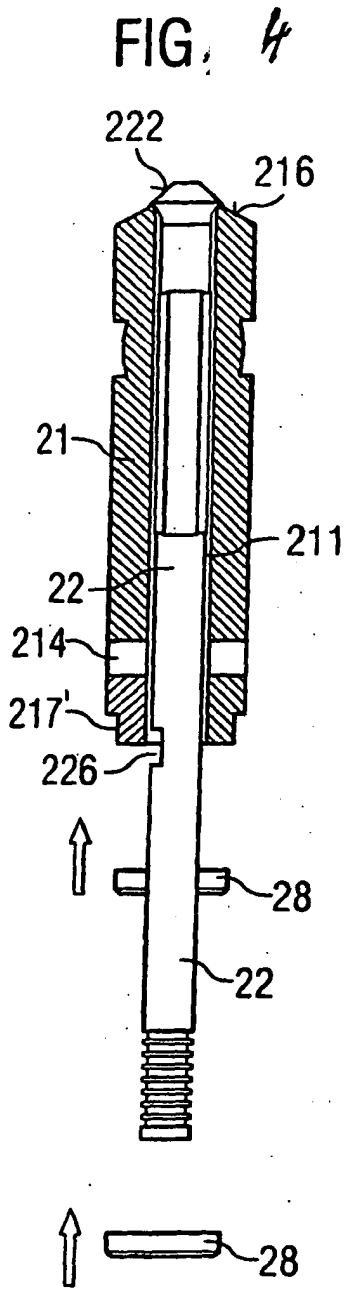

FIG 3





**REFERENCES CITED IN THE DESCRIPTION**

*This list of references cited by the applicant is for the reader's convenience only. It does not form part of the European patent document. Even though great care has been taken in compiling the references, errors or omissions cannot be excluded and the EPO disclaims all liability in this regard.*

**Patent documents cited in the description**

- WO 03016707 A1 [0003]
- EP 0512598 A1 [0004]