

(12) INTERNATIONAL APPLICATION PUBLISHED UNDER THE PATENT COOPERATION TREATY (PCT)

(19) World Intellectual Property
Organization
International Bureau

(43) International Publication Date
23 January 2025 (23.01.2025)



(10) International Publication Number
WO 2025/015367 A1

- (51) International Patent Classification:
E21D 21/00 (2006.01)
- (21) International Application Number:
PCT/AU2024/050725
- (22) International Filing Date:
03 July 2024 (03.07.2024)
- (25) Filing Language: English
- (26) Publication Language: English
- (30) Priority Data:
2023902259 14 July 2023 (14.07.2023) AU
- (72) Inventor; and
(71) Applicant: **CATOI, Peter Bryce** [AU/AU]; 26a Burke Drive, Attadale, Western Australia 6156 (AU).
- (74) Agent: **ARMOUR IP PTY LTD**; PO Box 3099, Broadway Nedlands, Western Australia 6009 (AU).

NG, NI, NO, NZ, OM, PA, PE, PG, PH, PL, PT, QA, RO, RS, RU, RW, SA, SC, SD, SE, SG, SK, SL, ST, SV, SY, TH, TJ, TM, TN, TR, TT, TZ, UA, UG, US, UZ, VC, VN, WS, ZA, ZM, ZW.

(84) Designated States (unless otherwise indicated, for every kind of regional protection available): ARIPO (BW, CV, GH, GM, KE, LR, LS, MW, MZ, NA, RW, SC, SD, SL, ST, SZ, TZ, UG, ZM, ZW), Eurasian (AM, AZ, BY, KG, KZ, RU, TJ, TM), European (AL, AT, BE, BG, CH, CY, CZ, DE, DK, EE, ES, FI, FR, GB, GR, HR, HU, IE, IS, IT, LT, LU, LV, MC, ME, MK, MT, NL, NO, PL, PT, RO, RS, SE, SI, SK, SM, TR), OAPI (BF, BJ, CF, CG, CI, CM, GA, GN, GQ, GW, KM, ML, MR, NE, SN, TD, TG).

Published:

— with international search report (Art. 21(3))

(81) Designated States (unless otherwise indicated, for every kind of national protection available): AE, AG, AL, AM, AO, AT, AU, AZ, BA, BB, BG, BH, BN, BR, BW, BY, BZ, CA, CH, CL, CN, CO, CR, CU, CV, CZ, DE, DJ, DK, DM, DO, DZ, EC, EE, EG, ES, FI, GB, GD, GE, GH, GM, GT, HN, HR, HU, ID, IL, IN, IQ, IR, IS, IT, JM, JO, JP, KE, KG, KH, KN, KP, KR, KW, KZ, LA, LC, LK, LR, LS, LU, LY, MA, MD, MG, MK, MN, MU, MW, MX, MY, MZ, NA,

(54) Title: ROCK BOLT

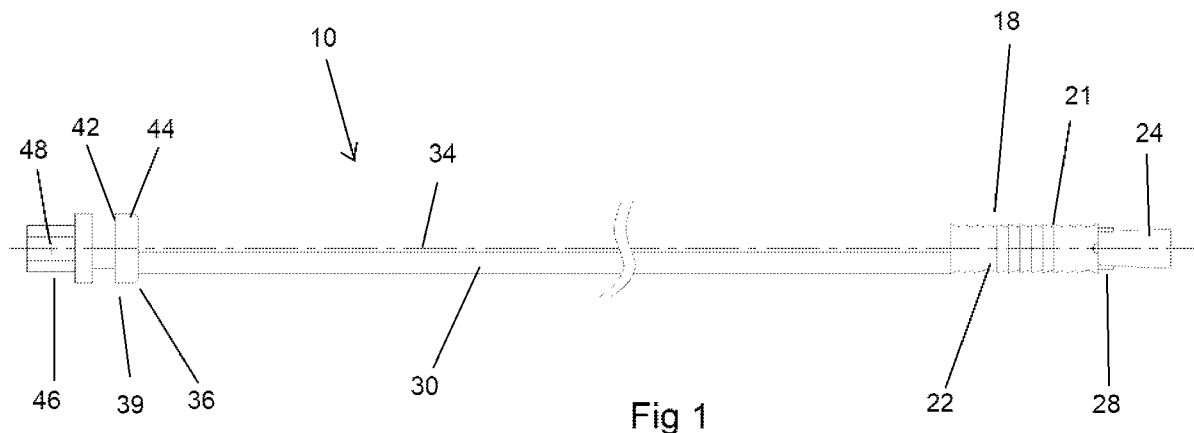

Fig 1

(57) Abstract: A rock bolt (10) comprising a shaft (12) having a first anchor member (18) and a first wedge member (24) adjacent the first anchor member (18). A sleeve (30) is received around the shaft (12) and an end member (36) is provided adjacent the outer end of the shaft (12) to engage with the shaft (12) and with the rock face around the hole. The first anchor member (18) includes a first portion (20) and a second portion (21) such that the first portion (20) is received into an end of the sleeve (30) and the second portion (21) extends beyond the sleeve (30) and is expandable by the first wedge member (24) to engage with the inner surface of the hole and secure the rock bolt (10) within the hole.



WO 2025/015367 A1

“ROCK BOLT”

Field of the Invention

[001] The present invention relates to a rock bolt.

Background to the Invention

[002] Rock bolts are used for stabilising the surface of an excavated area. Such rock bolts are inserted into a drilled hole in the rock face and secured in place by mechanical or adhesive means to the inner end of the hole. The rock bolts thereby transfers force from around the surface of the excavated surface to the more stable rock near the inner end of the drilled hole.

[003] Mechanical rock bolts generally utilise an expanding component located adjacent an inner end of the hole. The outer end of the rock bolt is then clamped to the surface of the rock face and tensioned. Adhesive fixing of rock bolts comprises inserting an epoxy into the hole which then sets, providing bonding between the rock bolt and the rock along the length of the drilled hole. This provides an advantage by spreading the load over a greater length.

[004] The present invention relates to a rock bolt aimed at providing a strong mechanical connection to the rock. The rock bolt allows for both easy and secure installation with secure connection to the surface of the rock inside the drilled hole in one or multiple locations.

Summary of the Invention

[005] According to one aspect of the present invention there is provided a rock bolt comprising:

a shaft having an inner end to be inserted into a hole drilled in a rock face and an outer end to extend beyond the rock face in use;

a first anchor member having an internal bore to receive the inner end of the shaft;

a first wedge member adjacent the first anchor member having an internal thread to engage with an inner thread adjacent the inner end of the shaft;

a sleeve received around the shaft; and

an end member provided adjacent the outer end of the shaft to engage with the shaft and with the rock face around the hole;

wherein the first anchor member includes a first portion and a second portion such that the first portion is received into an end of the sleeve and the second portion extends beyond the sleeve and is expandable by the first wedge member to engage with the inner surface of the hole and secure the rock bolt within the hole.

[006] Preferably the second end portion of the first anchor member includes a plurality of rock face engaging teeth.

[007] Preferably the rock face engaging teeth extend around the periphery of the second end portion of the first anchor member.

[008] Preferably the rock face engaging teeth are sawtooth in shape, being angled to restrict outward movement of the anchor member relative to the inner surface of the hole.

[009] Preferably the first end portion of the first anchor member includes a plurality of sleeve engaging teeth to engage with an inner surface of the inner end of the sleeve.

[010] Preferably the sleeve engaging teeth extend around the periphery of the first end portion of the first anchor member and are sawtooth in shape being oriented in the opposite direction to the rock face engaging teeth.

[011] Preferably the sleeve includes one or more longitudinal grooves extending from the inner end to the outer end thereof to allow the sleeve to be resiliently compressed when inserted into the hole.

[012] Preferably the grooves are generally V-shaped or U-shaped in cross section.

[013] In a one embodiment, the sleeve comprises a first sleeve section engaged with the first anchor member and a second sleeve section engaged with the end member and wherein a second anchor member is provided comprising:

a first portion received into an inner end of the second sleeve section;

a second portion exposed from the sleeve extending inwardly from the first portion;

a third portion received into an outer end of the first sleeve portion; and

a second wedge member engaging with an intermediate thread on the shaft such that rotation of the shaft engages the second wedge member with the second portion of the second anchor member to expand the second portion to engage with the inner surface of the hole.

[014] Preferably the first and third portions include sleeve engaging teeth.

[015] Preferably the sleeve engaging teeth extend around the periphery of the second anchor member and are sawtooth in shape oriented in opposite directions.

[016] Preferably the second portion of the second anchor member includes rock face engaging teeth.

[017] Preferably the rock face engaging teeth on the second anchor member are sawtooth in shape.

[018] Preferably the end member includes a first portion received into an outer end of the sleeve and a second portion comprising an annular flange to engage with the outer end of the sleeve.

[019] Preferably the flange is provided with a cylindrical lip extending in a direction towards the sleeve in use.

Brief Description of the Drawings

[020] The invention will now be described, by way of example, with reference to the following drawings, in which:

[021] Figure 1 is a side view of a rock bolt in accordance with the present invention;

[022] Figure 2 is a side view of the rock bolt of Figure 1 with portions of the outer sleeve cut away;

[023] Figure 3 is an exploded perspective view of components of the rock bolt prior to assembly;

[024] Figure 4 is a close up view of Detail A of Figure 3;

[025] Figure 5 is a close up view of Detail B of Figure 3;

[026] Figure 6 is an end view of the sleeve of the rock bolt;

[027] Figure 7 is a side view of a second embodiment of a rock bolt in accordance with the present invention;

[028] Figure 8 is a side view of the rock bolt of Figure 7 with portions of the outer sleeve cut away;

[029] Figure 9 is an exploded perspective view of components of the rock bolt of Figure 7 prior to assembly;

[030] Figure 10 is a close up view of Detail A of Figure 9;

[031] Figure 11 is a close up view of Detail C of Figure 9; and

[032] Figure 12 is a close up view of Detail B of Figure 9.

Detailed Description of Preferred Embodiments

[033] Referring to the Figures, there is shown a rock bolt 10 including a shaft 12 to be inserted into a hole drilled in a rock face. The shaft 12 includes an inner end 14, being the end inserted into the hole, and an outer end 15, being the end which protrudes beyond the rock face in use.

[034] The inner end 14 of the shaft 12 includes an inner threaded portion 16 and the outer end 15 of the shaft 12 includes an outer threaded portion 17. The inner threaded portion 16 is provided to engage with a first anchor member 18.

The first anchor member 18 is provided to engage with an inner surface of the hole adjacent an inner end thereof to secure the rock bolt 10 within the hole.

[035] The first anchor member 18 is tubular such that the inner end 14 of the shaft 12 is received through a bore provided extending through the length of the first anchor member 18. The first anchor member includes a first portion 20 and a second portion 21. The first portion 20 of the first anchor member 18 is provided to receive an inner end of a sleeve 30 provided to extend through the hole around the shaft 12. The second portion 21 of the first anchor member 18 extends outwardly from the inner end of the sleeve 30 and is expandable such that the second portion 21 of the first anchor member 18 may be expanded to engage with the inner surface of the drilled hole and secure the rock bolt 10 to the inner surface of the hole.

[036] The second portion 21 of the anchor member 18 includes a plurality of rock face engaging teeth 22. The rock face engaging teeth 22 each extend around the periphery of the second portion 21 of the anchor member 18 and are angled to engage with the inner surface of the hole to restrict outward movement of the anchor member 18 relative to the hole. The rock face engaging teeth 22 in the embodiment shown are sawtooth in shape.

[037] A first wedge member 24 is provided to engage with the inner threaded portion 16 on the inner end 14 of the shaft 12. The first wedge member 24 comprises a tapered cylinder having an internal thread to engage with the inner threaded portion 16. The first anchor member 18 includes one or more longitudinal slots 26 extending along the second portion 21 thereof such that as the wedge member 24 is pulled into the second portion 21, the second portion 21 of the anchor member 18 is widened to engage with the inner surface of the hole. The wedge member 24 includes one or more lugs 28 on an outer surface thereof to engage into the slots 26 in the first anchor member 18 to prevent rotation of the wedge member 24 relative to the first anchor member 18.

[038] An inner end of the sleeve 30 engages around the outside of the first portion 20 of the first anchor member 18. The first portion 20 of the anchor member 18 includes a plurality of sleeve engaging teeth 32 around the

periphery thereof. The sleeve engaging teeth 32 on the first portion 20 are angled in order to restrict movement of the first portion 20 of the first anchor member 18 outwardly from the inner end of the sleeve 30. The sleeve engaging teeth 32 comprise sawtooth shaped teeth extending around the periphery of the first portion 20 and being oriented in the opposite direction to the rock face engaging teeth 22.

[039] The sleeve 30 is formed from a relatively thin cylinder of a suitable material such as a thin metallic material. The sleeve 30 includes one or more longitudinal grooves 34 extending from the inner end to the outer end thereof. In embodiment shown, the grooves 34 are generally V-shaped or U-shaped in cross section (as can be seen in Figure 6). The grooves 34 and the material of the sleeve 30 allow the sleeve 30 to be compressed slightly as it is inserted into the drilled hole. The sleeve 30 is resilient such that after compression, the sleeve 30 tends to expand such that the outer surface of the sleeve 30 engages with an inner surface of the hole to support the rock bolt 10 prior to expansion of the first anchor member 18. Further the inner sides of the grooves 34 aid in engaging with the sleeve engaging teeth 32 in the first anchor member 18 to secure the first anchor member 18 into the inner end of the sleeve 30.

[040] The rock bolt 10 is provided also with an end member 36. The end member 36 is engageable into the outer end of the sleeve 30. The end member 36 is tubular and has an inner end portion 38 having a plurality of sleeve engaging teeth 40 around the periphery thereof. The sleeve engaging teeth 40 on the inner end portion 38 of the end member 36 comprise sawtooth shaped annular teeth being angled to restrict movement of the inner end portion 38 of the end member 36 outwardly from the sleeve 30. The inner end portion 38 of the end member 36 and the first portion 20 of the first anchor member 18 are dimensioned to be slightly larger than the inner diameter of the sleeve 30 such that the sleeve engaging teeth 32 and 40 of the first anchor member 18 and end member 36 bite into inner surfaces of the grooves 34. The anchor member 18 and the end member 36 may be pushed into the ends of the sleeve 30 under force and will then lock in place to the sleeve 30.

[041] The end member 36 includes an outer end portion 39 comprising an annular flange 42. The annular flange 42 engages with the outer end of the sleeve 30. The flange 42 is provided also with a cylindrical lip 44 extending in a direction towards the sleeve 30 in use. The outer end of the sleeve 30 engages into the inner surface of the lip 44 as can be seen in Figure 2.

[042] A nut 46 engages onto the outer threaded portion 17 of the shaft 12. The nut 46 may be tightened by operation with a suitable tool. A dowel 48 is passed through aligned holes in the nut 46 and the outer end 15 of the shaft 12 such that rotation of the nut 46 causes rotation of the shaft 12. Rotation of the shaft 12 draws the wedge member 24 inwardly into the first anchor member 18, thereby widening the first portion 20 of the anchor member 18 to engage with the inner surface of the hole. The dowel 48 is dimensioned such that when sufficient torque has been applied to the shaft 12 to fully engage the anchor member 18, the dowel 48 will snap allowing rotation of the nut 46 relative to the second threaded portion 17 to move the nut 46 towards the rock face.

[043] The rock bolt 10 is provided also with a tubular member 50 received about the shaft 12 adjacent the end member 36. The tubular member 50 includes an inner thread to engage with the outer threaded portion 17 such that the tubular member 50 is located adjacent the end member 36 within the sleeve 30. In the embodiment shown, the tubular member 50 is tapered inwardly towards the end member 36 such that an end of the tubular member 50 adjacent the end member 36 may engage into the end of the inner end portion 38 of the end member 36.

[044] The tubular member 50 is provided such that should the shaft 12 break and the outer end 15 of the shaft 12 therefore move outwardly relative to the hole, the tubular member 50 will engage with the inner end portion 38 of the end member 36 and thereby prevent the broken lower portion of the shaft 12 from falling outwardly from the hole. The tubular member 50 is positioned initially a distance above the end member 36 such that the shaft 12 may move downwardly this distance in the event of the breakage. The outer end 15 of the shaft 12 and the nut 46 will then move downwardly by this distance out of the

end of the hole as a visible indication that the shaft 12 has broken. The tubular member 50 may be formed from a suitable plastic material, such as nylon.

[045] In use, the rock bolt 10 may be inserted into the drilled hole with the first anchor member 18 located adjacent an inner end of the hole and the end member 36 located adjacent the rock face around the hole. The sleeve 30 allows the outer surface of the rock bolt 10 to engage with the inner surface of the hole with some compression of the sleeve. This engages the rock bolt 10 with the hole to hold it in place. The structure of the first anchor member 18 however leaves the second end 21 thereof exposed to engage with the inner surface of the hole and clamp in place with rotation of the shaft 12.

[046] Figures 7 to 12 show a second embodiment of a rock bolt 10 in accordance with the present invention. The embodiment of Figures 7 to 12 is similar to the previous embodiment and like reference numerals are used to denote like parts.

[047] The embodiment of Figures 7 to 12 includes a second anchor member 58. The second anchor member 58 also comprises a tubular member provided to receive the shaft 12 through a central bore and is to be located in use between the first anchor member 18 and the end member 36. In the embodiment shown, there is provided an intermediate thread portion 19 on the shaft 12 between the inner and outer ends 14 and 16. The second anchor member 58 is provided adjacent the intermediate thread portion 19. It will be appreciated however that other configurations of the thread may be utilised, such as a continuous thread along the whole length of the shaft.

[048] The sleeve 30 is provided in two sections. A first sleeve section 52 is provided extending between the first and second anchor members 18 and 58 and a second sleeve section 53 is provided extending between the second anchor member 58 and the end member 36.

[049] The second anchor member 58 includes a first portion 60 provided to engage into an inner end of the second sleeve section 53. The first portion 60 includes a plurality of sleeve engaging teeth 32 of the same configuration as those on the first portion 20 of the first anchor member 18. The second anchor

member 58 includes a second portion 61 extending inwardly of the first portion 60 and exposed from the sleeve 30. The second portion 61 is expandable and of a similar configuration to the second portion 21 of the first anchor member 18. The second portion 61 therefore includes a slot 26 to receive lugs 28 on a second wedge member 64 that engages with the intermediate thread portion 19 in use. The second wedge member 61 is provided to be drawn in towards the second portion 61 of the second anchor member 58 by rotation of the shaft 12. The second portion 61 of the second anchor member 58 includes rock face engaging teeth 22 to engage with an inner surface of the hole when the second portion 61 is expanded.

[050] The second anchor member 58 includes also a third portion 62. The third portion extends inwardly from the second portion 61 and is of the same narrowed configuration as the first portion 60 to be received into the outer end of the first sleeve section 52. The third portion 62 includes sleeve engaging teeth 32 of a similar configuration to those of the first portion 60 of the second anchor member 58 but angled in an opposite direction. The second wedge member 61 is located initially in use adjacent the third portion 62.

[051] The rock bolt 10 of Figures 7 to 12 may be used in a similar manner to the previous embodiment. That is, the rock bolt 10 may be inserted into the hole with the sleeve sections 52 and 53 holding the rock bolt 10 in place during installation. The exposed second portions 21 and 61 of both the first and second anchor members 18 and 58 will expand outwardly to clamp the rock bolt 10 in place in multiple locations.

[052] It will be readily apparent to persons skilled in the relevant arts that various modifications and improvements may be made to the foregoing embodiments, in addition to those already described, without departing from the basic inventive concepts of the present invention.

Claims

- 5 1. A rock bolt comprising:
a shaft having an inner end to be inserted into a hole drilled in a rock face and
an outer end to extend beyond the rock face in use;
a first anchor member having an internal bore to receive the inner end of the
shaft;
- 10 a first wedge member adjacent the first anchor member having an internal
thread to engage with an inner thread adjacent the inner end of the shaft;
a sleeve received around the shaft; and
an end member provided adjacent the outer end of the shaft to engage with the
shaft and with the rock face around the hole;
- 15 wherein the first anchor member includes a first portion and a second portion
such that the first portion is received into an end of the sleeve and the second
portion extends beyond the sleeve and is expandable by the first wedge
member to engage with the inner surface of the hole and secure the rock bolt
within the hole.
- 20 2. A rock bolt in accordance with claim 1, wherein the second end portion
of the first anchor member includes a plurality of rock face engaging teeth.
3. A rock bolt in accordance with claim 2, wherein the rock face engaging
teeth extend around the periphery of the second end portion of the first anchor
member.
- 25 4. A rock bolt in accordance with claim 3, wherein the rock face engaging
teeth are sawtooth in shape, being angled to restrict outward movement of the
anchor member relative to the inner surface of the hole.
5. A rock bolt in accordance with any one of the preceding claims, wherein
the first end portion of the first anchor member includes a plurality of sleeve
30 engaging teeth to engage with an inner surface of the inner end of the sleeve.

6. A rock bolt in accordance with claim 5, wherein the sleeve engaging teeth extend around the periphery of the first end portion of the first anchor member and are sawtooth in shape being oriented in the opposite direction to the rock face engaging teeth.
- 5 7. A rock bolt in accordance with any one of claims 1 to 6, wherein the sleeve includes one or more longitudinal grooves extending from the inner end to the outer end thereof to allow the sleeve to be resiliently compressed when inserted into the hole.
8. A rock bolt in accordance with claim 7, wherein the grooves are generally
10 V-shaped or U-shaped in cross section.
9. A rock bolt in accordance with any one of the preceding claims, wherein the sleeve comprises a first sleeve section engaged with the first anchor member and a second sleeve section engaged with the end member and wherein a second anchor member is provided comprising:
15 a first portion received into an inner end of the second sleeve section;
a second portion exposed from the sleeve extending inwardly from the first portion;
a third portion received into an outer end of the first sleeve portion; and
a second wedge member engaging with an intermediate thread on the shaft
20 such that rotation of the shaft engages the second wedge member with the second portion of the second anchor member to expand the second portion to engage with the inner surface of the hole.
10. A rock bolt in accordance with claim 9 wherein the first and third portions include sleeve engaging teeth.
- 25 11. A rock bolt in accordance with claim 10, wherein the sleeve engaging teeth extend around the periphery of the second anchor member and are sawtooth in shape oriented in opposite directions.
12. A rock bolt in accordance with any one of claims 9 to 11, wherein the second portion of the second anchor member includes rock face engaging
30 teeth.

13. A rock bolt in accordance with claim 12, wherein the rock face engaging teeth on the second anchor member are sawtooth in shape.

14. A rock bolt in accordance with any one of the preceding claims, wherein the end member includes a first portion received into an outer end of the sleeve
5 and a second portion comprising an annular flange to engage with the outer end of the sleeve.

15. A rock bolt in accordance with claim 14, wherein the flange is provided with a cylindrical lip extending in a direction towards the sleeve in use.

10

1 / 12

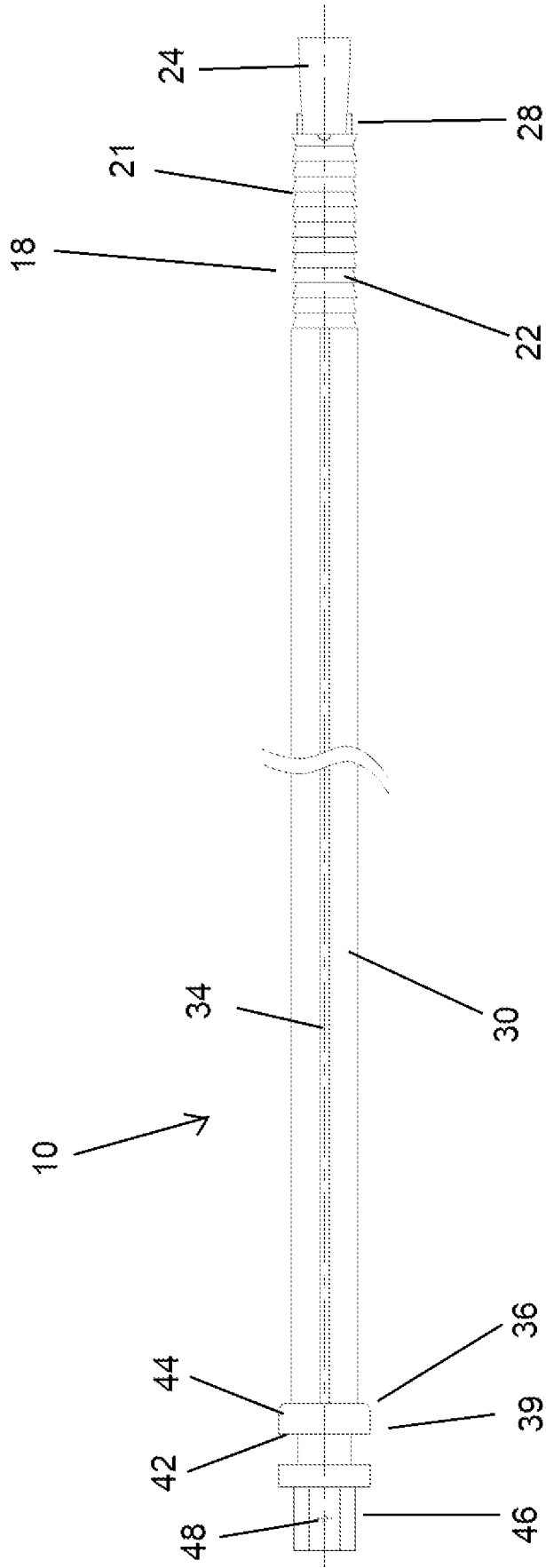

Fig 1

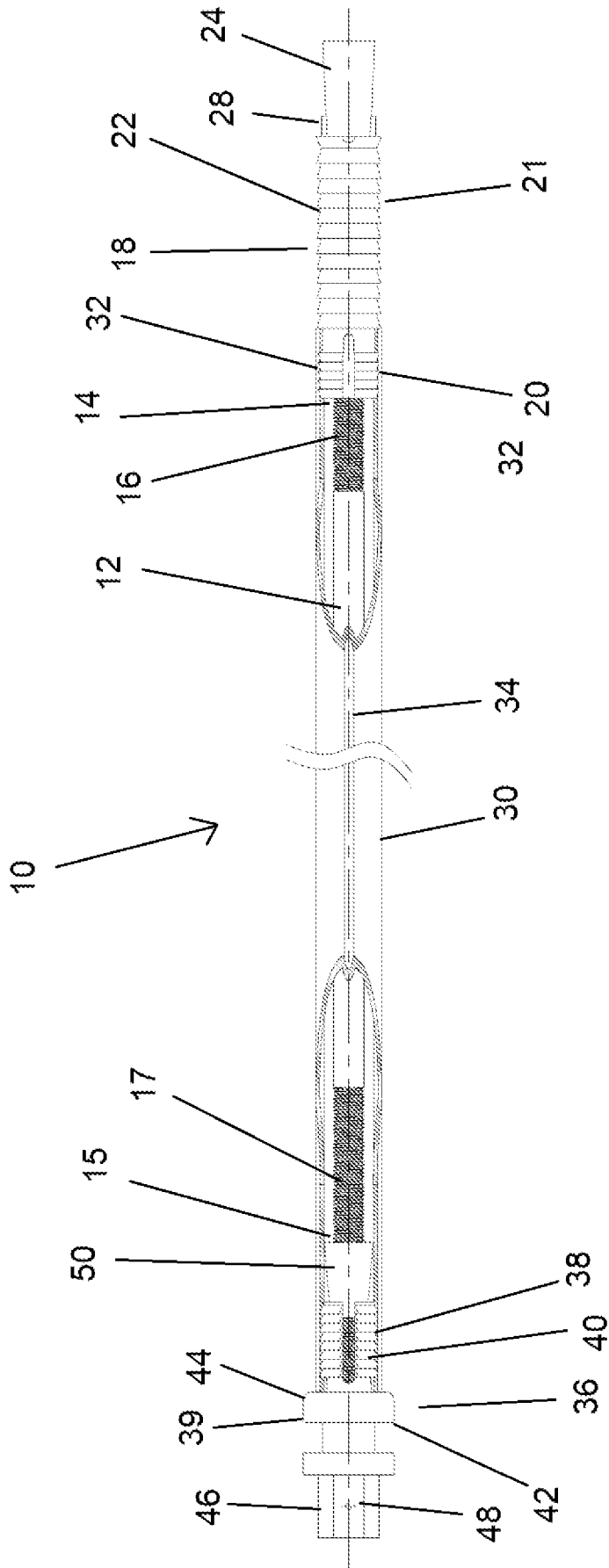

Fig 2

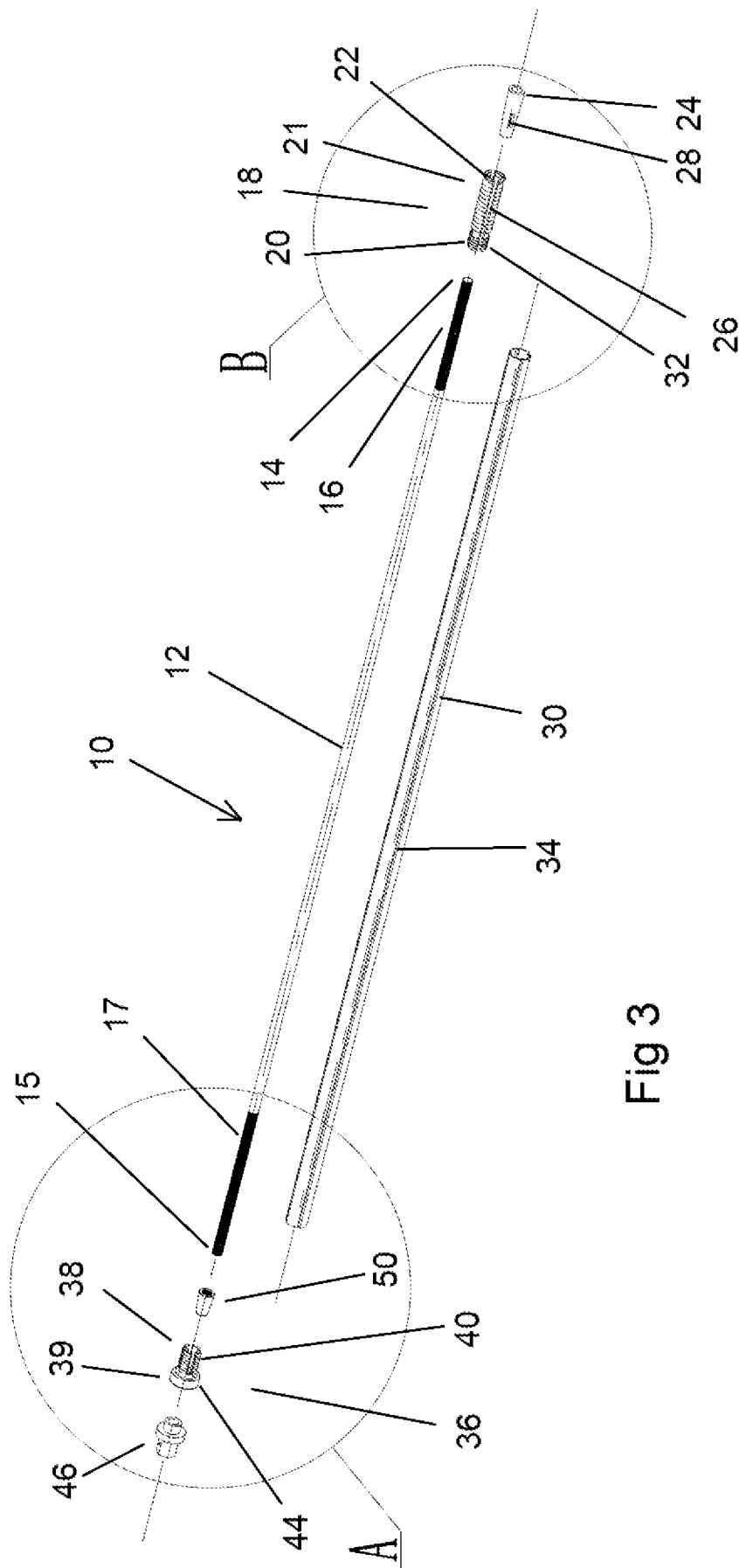

Fig 3

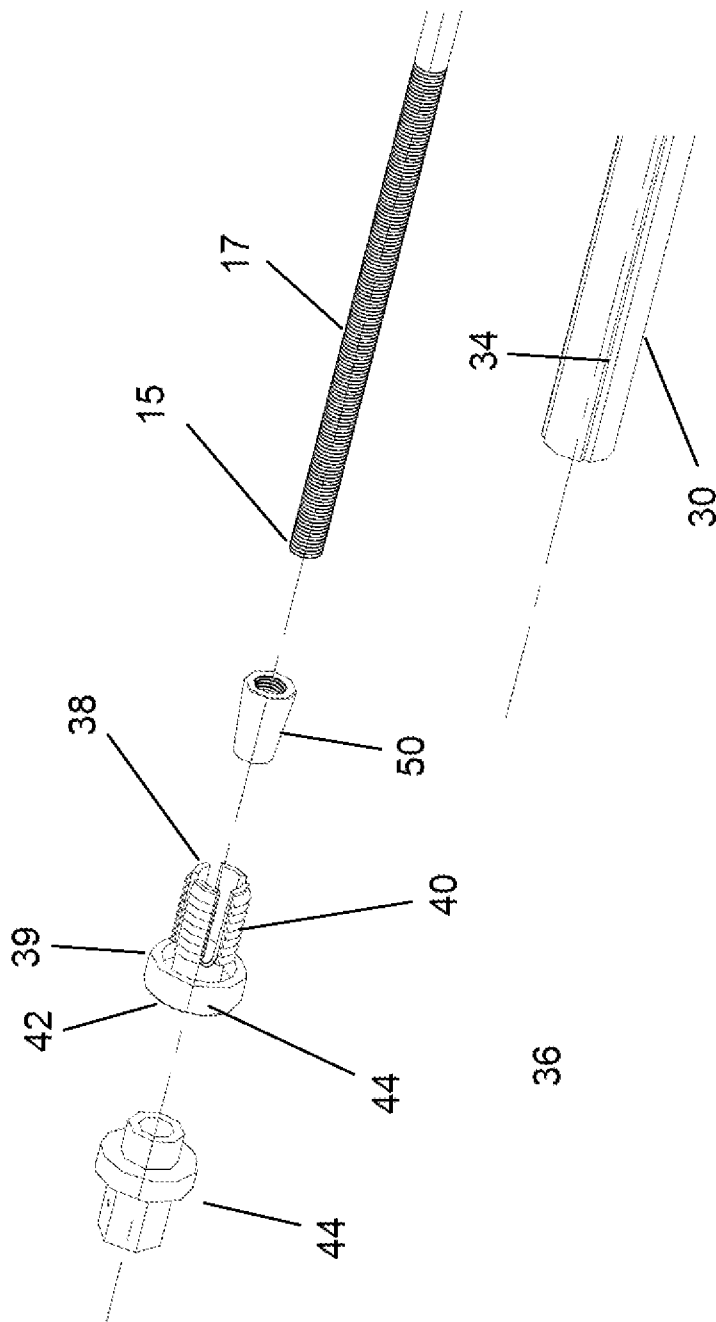

Fig 4

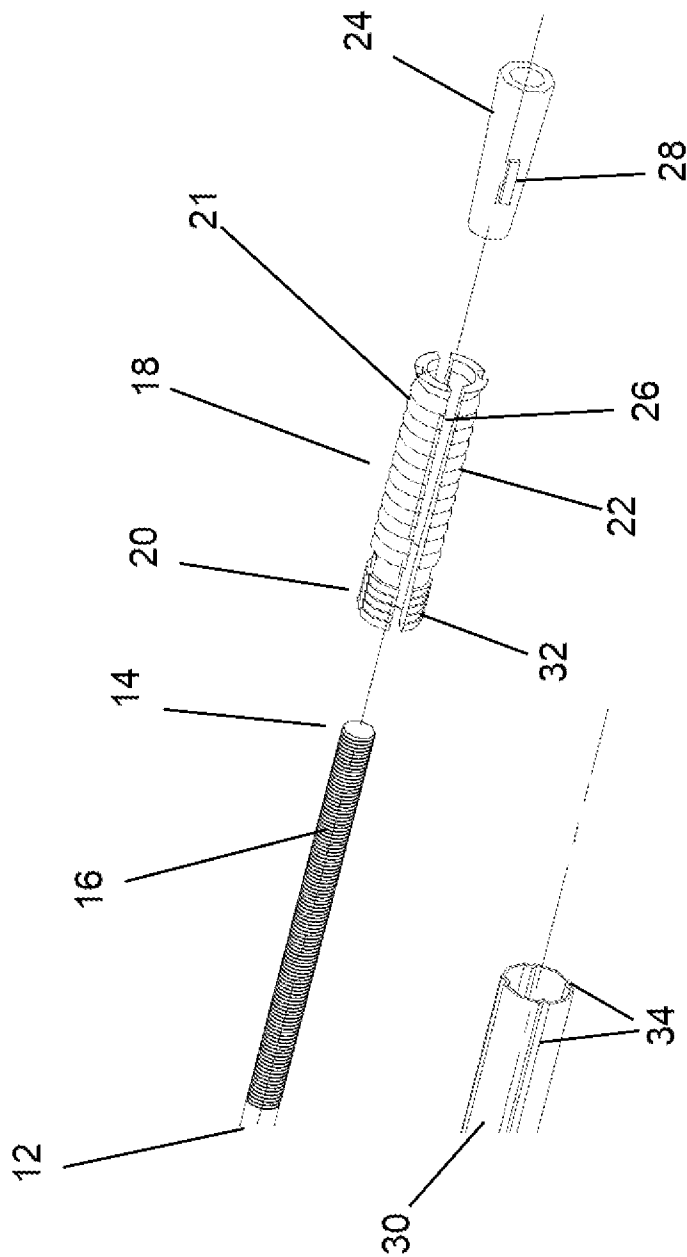

Fig 5

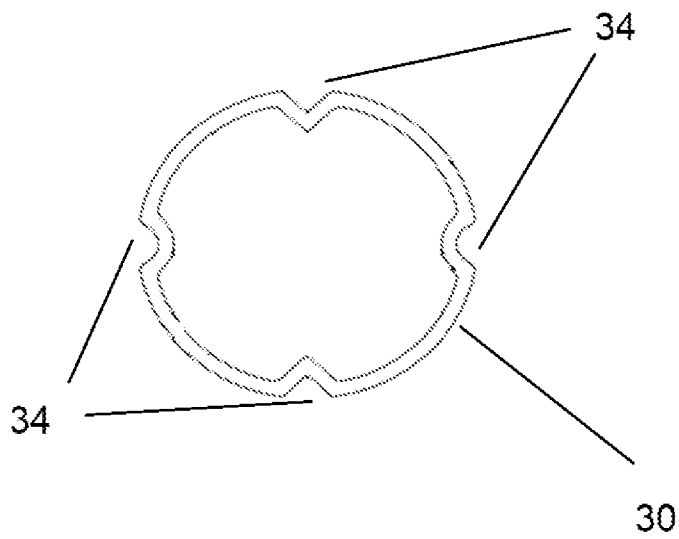

Fig 6

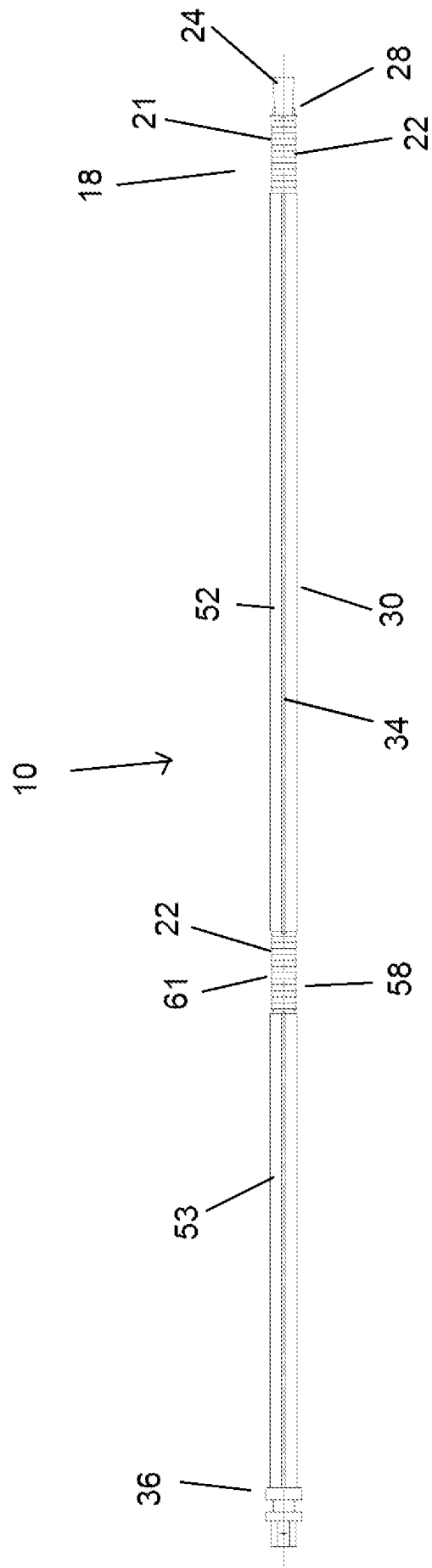
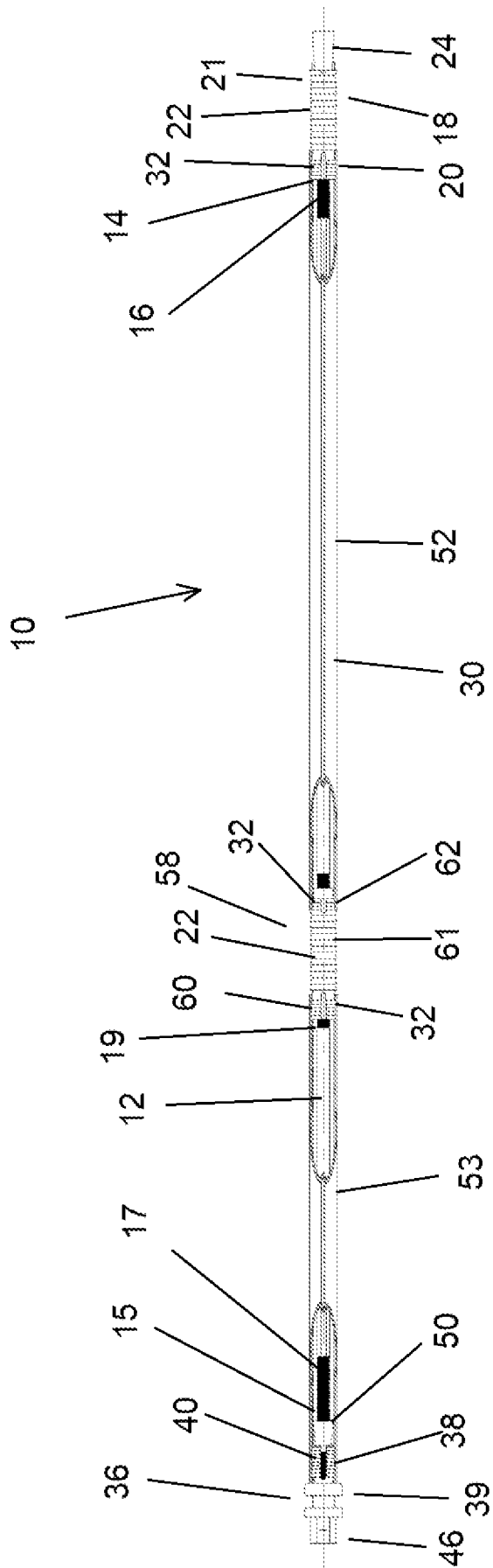

Fig 7

8 / 12



8 / 12

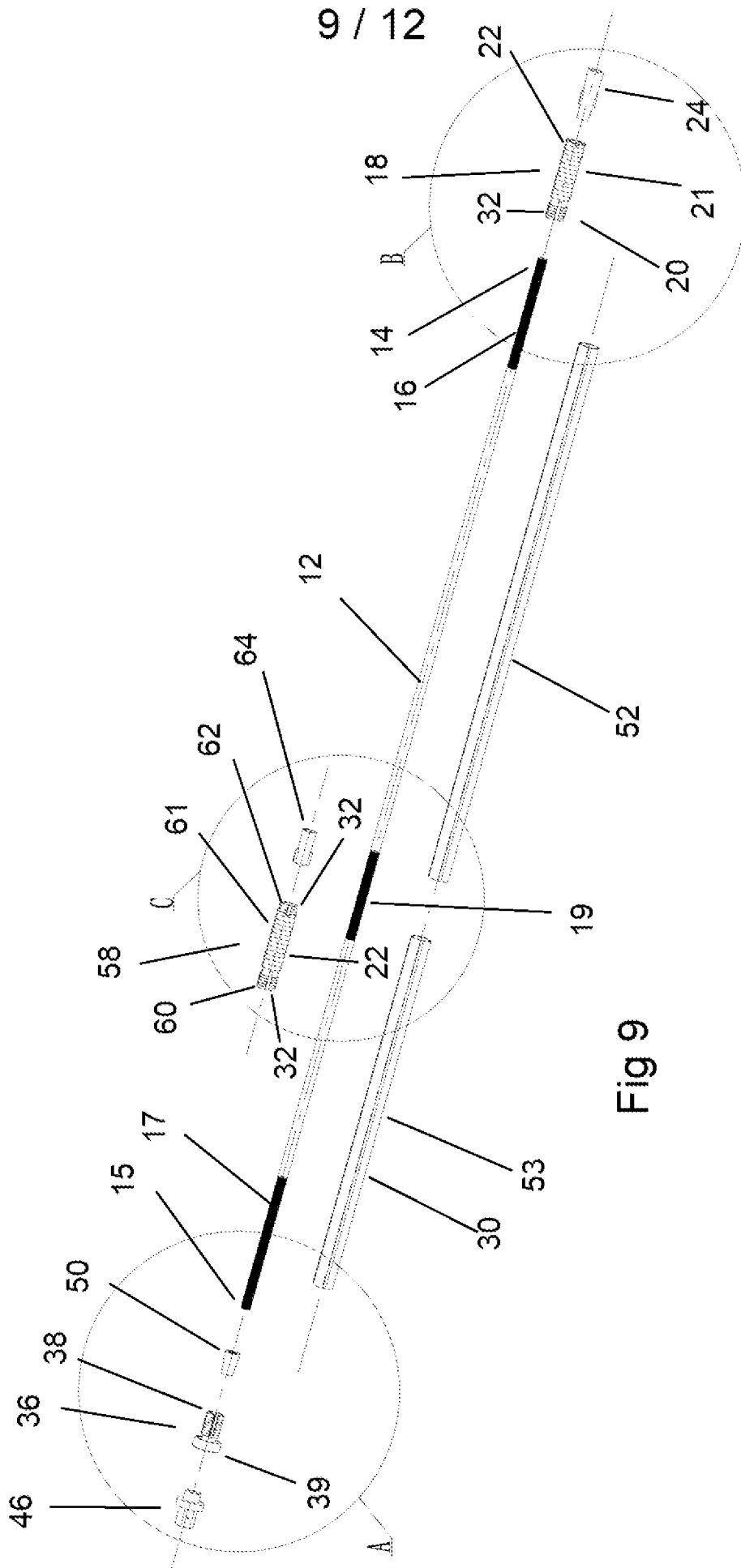

Fig 9

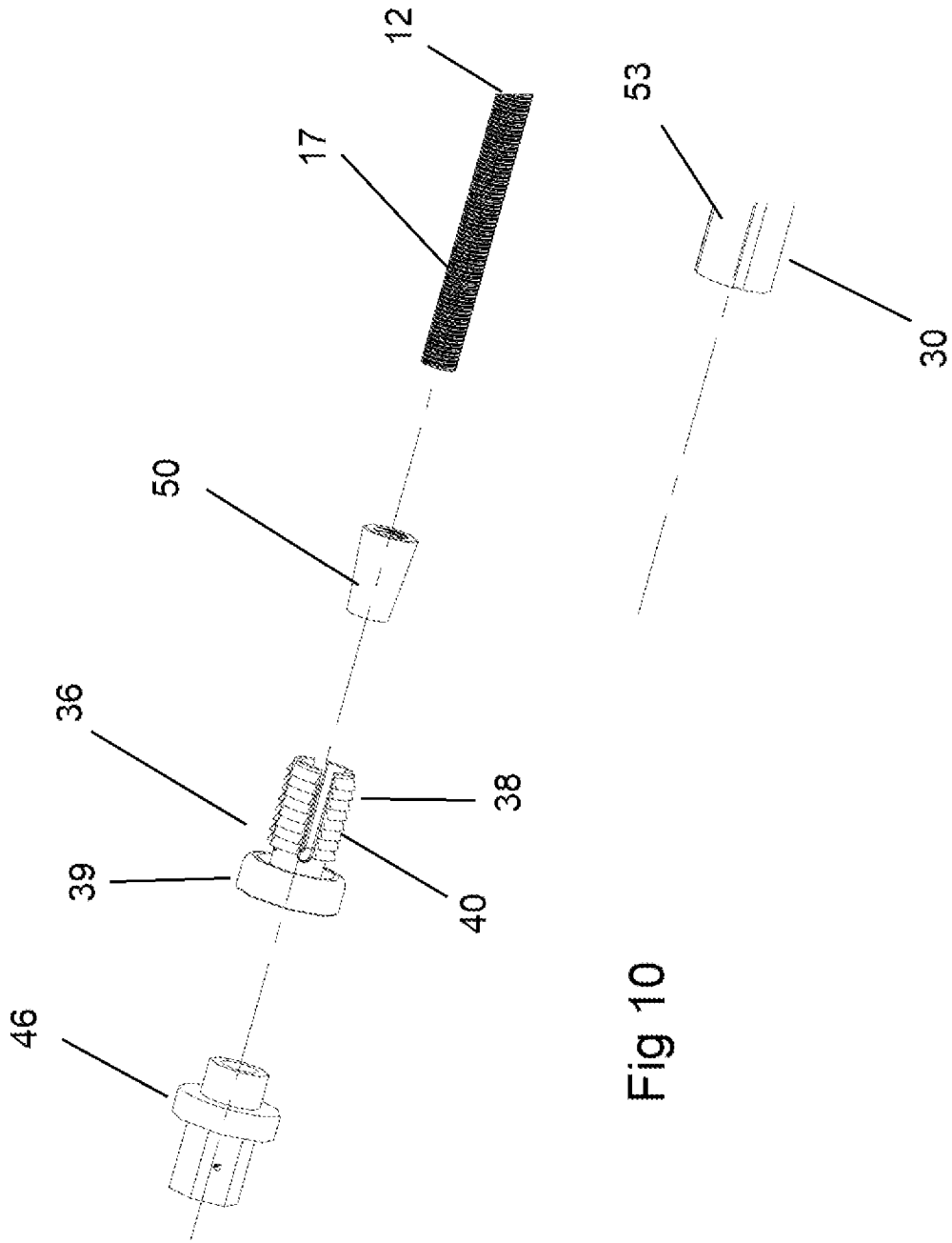

Fig 10

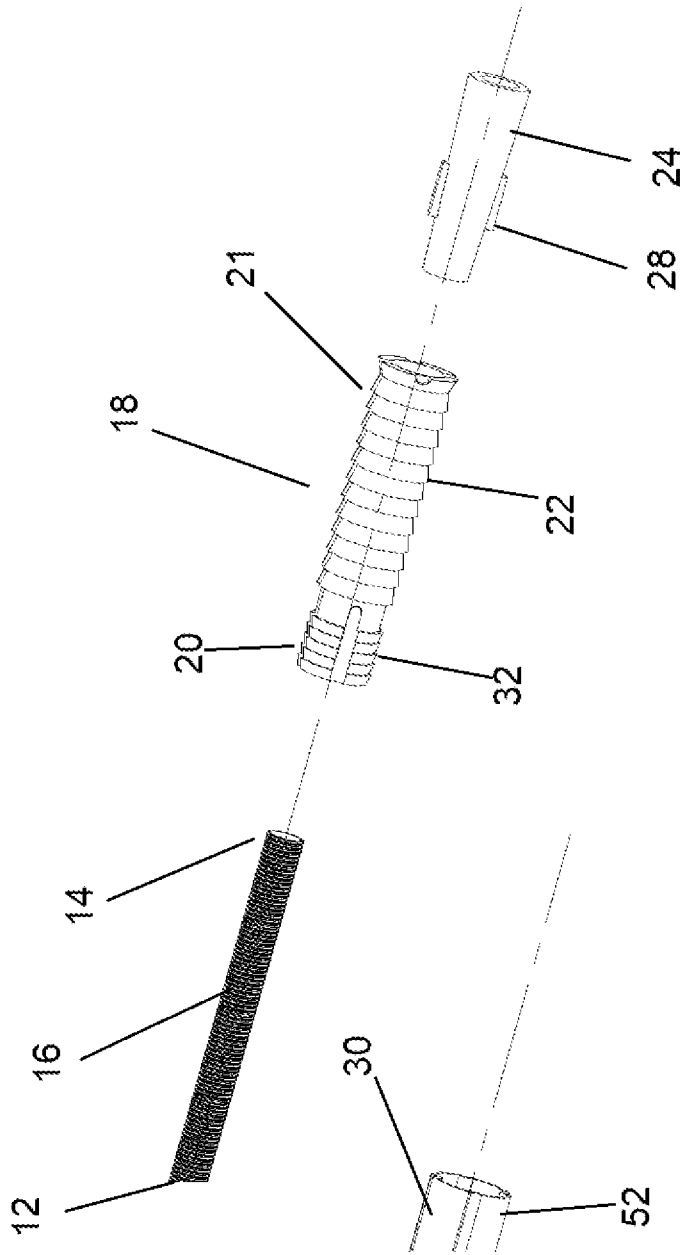

Fig 12

A. CLASSIFICATION OF SUBJECT MATTER

E21D 21/00 (2006.01)

According to International Patent Classification (IPC) or to both national classification and IPC

B. FIELDS SEARCHED

Minimum documentation searched (classification system followed by classification symbols)

Documentation searched other than minimum documentation to the extent that such documents are included in the fields searched

Electronic data base consulted during the international search (name of data base and, where practicable, search terms used)

EPODOC, WPI: IPC: CPC:E21D21/0033,E21D21/004, E21D21/0046, E21D21/0053, E21D21/008, E21D21/0026, E21D21/0093 and keywords: SLEEVE, JACKET, EXPAND, SWELL, WEDGE, TAPER, THREAD, BORE, TANDEM, CO_JOIN and other like terms.

EspaceNet/AusPAT - CATOI PETER BRYCE as the applicant .

C. DOCUMENTS CONSIDERED TO BE RELEVANT

Category*	Citation of document, with indication, where appropriate, of the relevant passages	Relevant to claim No.
Documents are listed in the continuation of Box C		

 Further documents are listed in the continuation of Box C See patent family annex

* Special categories of cited documents:		
"A" document defining the general state of the art which is not considered to be of particular relevance	"T" later document published after the international filing date or priority date and not in conflict with the application but cited to understand the principle or theory underlying the invention	
"D" document cited by the applicant in the international application	"X" document of particular relevance; the claimed invention cannot be considered novel or cannot be considered to involve an inventive step when the document is taken alone	
"E" earlier application or patent but published on or after the international filing date	"Y" document of particular relevance; the claimed invention cannot be considered to involve an inventive step when the document is combined with one or more other such documents, such combination being obvious to a person skilled in the art	
"L" document which may throw doubts on priority claim(s) or which is cited to establish the publication date of another citation or other special reason (as specified)	"&" document member of the same patent family	
"O" document referring to an oral disclosure, use, exhibition or other means		
"P" document published prior to the international filing date but later than the priority date claimed		

Date of the actual completion of the international search
9 September 2024Date of mailing of the international search report
09 September 2024

Name and mailing address of the ISA/AU

AUSTRALIAN PATENT OFFICE
PO BOX 200, WODEN ACT 2606, AUSTRALIA
Email address: pct@ipaaustralia.gov.au

Authorised officer

Vineet Naidu
AUSTRALIAN PATENT OFFICE
(ISO 9001 Quality Certified Service)
Telephone No. +61 2 6283 2841

INTERNATIONAL SEARCH REPORT

International application No.

C (Continuation).

DOCUMENTS CONSIDERED TO BE RELEVANT

PCT/AU2024/050725

Category*	Citation of document, with indication, where appropriate, of the relevant passages	Relevant to claim No.
X	WO 2018/055536 A1 (FCI HOLDINGS DELAWARE, INC) 29 March 2018 Figures	1 - 15
X	WO 2017/100818 A1 (DYWIDAG-SYSTEMS INTERNATIONAL PTY LIMITED) 22 June 2017 Figures	1 - 15
X	US 4664561 A (FREASE) 12 May 1987 Figures	1 - 15

INTERNATIONAL SEARCH REPORT

Information on patent family members

International application No.

PCT/AU2024/050725

This Annex lists known patent family members relating to the patent documents cited in the above-mentioned international search report. The Australian Patent Office is in no way liable for these particulars which are merely given for the purpose of information.

Patent Document/s Cited in Search Report		Patent Family Member/s	
Publication Number	Publication Date	Publication Number	Publication Date
WO 2018/055536 A1	29 March 2018	WO 2018055536 A1	29 Mar 2018
		AU 2017332855 A1	18 Apr 2019
		AU 2017332855 B2	10 Nov 2022
		US 2019277138 A1	12 Sep 2019
		US 10731463 B2	04 Aug 2020
WO 2017/100818 A1	22 June 2017	WO 2017100818 A1	22 Jun 2017
		AU 2016369657 A1	21 Jun 2018
		AU 2016369657 B2	28 Apr 2022
		CA 3008179 A1	22 Jun 2017
US 4664561 A	12 May 1987	US 4664561 A	12 May 1987

End of Annex