



## INTERNATIONAL APPLICATION PUBLISHED UNDER THE PATENT COOPERATION TREATY (PCT)

<p>(51) International Patent Classification <sup>5</sup> : <b>B65G 1/04</b></p>	<p><b>A1</b></p>	<p>(11) International Publication Number: <b>WO 92/15509</b></p> <p>(43) International Publication Date: 17 September 1992 (17.09.92)</p>
<p>(21) International Application Number: PCT/US92/02110</p> <p>(22) International Filing Date: 11 March 1992 (11.03.92)</p> <p>(30) Priority data: 667,546                      11 March 1991 (11.03.91)      US</p> <p>(71) Applicant: SARDEE INDUSTRIES, INC. [US/US]; 11900 South Laramie Avenue, Alsip, IL 60058 (US).</p> <p>(72) Inventors: CHIAPPE, Wayne, T. ; 731 East 7th Street, Hinsdale, IL 60521 (US). GASQUOINE, Randy, War- ren ; 9636 Majestic Lane, Stockton, CA 95209 (US).</p> <p>(74) Agent: CORNELL, John, W.; Lockwood, Alex, Fitzgibbon &amp; Cummings, Three First National Plaza, Suite 1700, Chicago, IL 60602 (US).</p>		<p>(81) Designated States: AT (European patent), BE (European patent), CA, CH (European patent), DE (European patent), DK (European patent), ES (European patent), FR (European patent), GB (European patent), GR (European patent), IT (European patent), JP, LU (European patent), MC (European patent), NL (European patent), SE (European patent).</p> <p><b>Published</b> <i>With international search report.</i></p>
<p>(54) Title: HIGH SPEED/HIGH CAPACITY AUTOMATED WORKLOAD REGULATOR</p>		
<p>(57) Abstract</p> <p>A high speed, high capacity automated workload regulator (10) is provided including a transfer station (12) having a transfer axis (a) and a transfer mechanism (14) capable of picking up, moving and depositing preformed groups (58) of articles (56), such as can ends, at various locations defined in the transfer station (12) along the transfer axis (a). In accordance with the preferred embodiment, a string of articles (54) is first subdivided to form successive groups of articles (58) preparatory to transfer. Each group (58) is advanced uphill against the force of gravity into an inbound staging area (34) at the transfer station (12) awaiting pick up by the transfer mechanism (14). Each group (58) is also advanced downhill with the force of gravity from an outbound staging area (36) defined in the transfer station (12) along outfeeder tracks (64) to outfeed consolidator mechanisms (32) which take successive groups of articles and re-form them into long strings (54) or continuous linear arrays for feeding to a downstream workstation.</p>		

**FOR THE PURPOSES OF INFORMATION ONLY**

Codes used to identify States party to the PCT on the front pages of pamphlets publishing international applications under the PCT.

AT	Austria	FI	Finland	ML	Mali
AU	Australia	FR	France	MN	Mongolia
BB	Barbados	GA	Gabon	MR	Mauritania
BE	Belgium	GB	United Kingdom	MW	Malawi
BF	Burkina Faso	GN	Guinea	NI	Netherlands
BG	Bulgaria	GR	Greece	NO	Norway
BJ	Benin	HU	Hungary	PL	Poland
BR	Brazil	IE	Ireland	RO	Romania
CA	Canada	IT	Italy	RU	Russian Federation
CF	Central African Republic	JP	Japan	SD	Sudan
CG	Congo	KP	Democratic People's Republic of Korea	SE	Sweden
CH	Switzerland	KR	Republic of Korea	SN	Senegal
CI	Côte d'Ivoire	LI	Liechtenstein	SU	Soviet Union
CM	Cameroon	LK	Sri Lanka	TD	Chad
CS	Czechoslovakia	LU	Luxembourg	TG	Togo
DE	Germany	MC	Monaco	US	United States of America
DK	Denmark	MG	Madagascar		
ES	Spain				

**HIGH SPEED/HIGH CAPACITY AUTOMATED WORKLOAD REGULATOR****BACKGROUND OF THE INVENTION**

The present invention generally relates to apparatus and methods for continuously, automatically and dynamically regulating the flow of manufactured articles in an automated multi-step manufacturing setting. More particularly, it relates to a new and improved automated workload balancer for use in automated manufacturing lines having an improved transfer and storage arrangement and improved article management features adapted to provide article handling rates of above about 5,000 articles per minute, and preferably between about 7,500 about 10,000 articles per minute.

An automated workload regulator apparatus for use in automated manufacturing operations is known from US 4,808,057 issued February 28, 1989 and US 4,983,095 which issued January 8, 1991, both of which are assigned to the same assignee as the present invention. In accordance with the apparatus and method defined in these patents, the preferred articles are can lids or ends which are stamped from a roll or sheet of metal stock at a first stamping operation and work station. The stamped can ends are transferred to successive downstream workstations where a number of subsequent manufacturing operations are or may be performed including: a shaping operation whereat the curled edge portion is imparted to each can end which is subsequently used in securing the can end to a can body; liner operations, wherein various coating compounds are applied to the inside surface of the can end preparatory to sealing of the can end to a can body; drying operations, to dry or cure the coatings applied in the liner operations; conversion press operations, wherein the easy open score

-2-

lines and pop-top tab rings are stamped and affixed to each lid, respectively; packaging operations, wherein a predetermined number of can ends are packaged in a tubular paper sleeve wrapper in trays or boxes, and finally, 5 palletizing and shrink or stretch wrapping operations, wherein sticks or packaged sleeves of can ends are stacked onto a pallet and wrapped in heat-shrink or stretch type plastic wrap for safe-keeping in temporary storage.

The balancer apparatus is positioned between two 10 adjacent work stations to promote maximum, through-put or output from the overall manufacturing operation by permitting uninterrupted operation of at least one of the workstations at its desired operating rate even though the other workstation is experiencing an intermittent or 15 variable operating rate.

The apparatus described in the aforementioned patents includes a transfer station having an associated inbound staging area, an outbound staging area and a storage area. As shown in the patent drawings, the inbound staging 20 area and the outbound staging area each comprise a plurality of adjacent parallel lanes and preferably the inbound and outbound staging areas are disposed in adjacent, side by side relation in a common horizontal plane extending through the transfer station. The storage area is defined by a 25 horizontal conveyor extending parallel to the staging areas but spaced vertically below the staging areas. A gap or separation is provided between the inbound and outbound lanes at the transfer station. The horizontal conveyor is designed to receive and index a storage tray having a 30 plurality of parallel troughs or receptacle portions, each for receiving a stick of can ends, in either of two

-3-

A transfer head having gripping and releasing means for grabbing a stick of can ends is positioned at the transfer station and is capable of a limited range of movement along the two axes in the transfer station. The transfer head can move a stick of ends from an inbound lane at the inbound staging area to an outbound lane at the outbound staging area or it can move the stick from the inbound lane downwardly to a centrally positioned empty trough in the storage tray positioned at the central location in the transfer station. In addition, the transfer head may grip a stick of can ends from a trough in the storage tray and deposit it in an outbound lane.

The balancer apparatus described in these patents further includes an empty container magazine and a full container magazine located at the opposed ends of the horizontal conveyor, respectively. Each magazine includes elevator means for upstacking or downstacking a given number of storage trays and for cooperatively loading them one at a time from magazine storage onto the horizontal conveyor for indexing through the transfer station.

In accordance with the apparatus and its mode of operation, a number of sensors and a controller module determine the cumulative inbound rate of can ends or rather the sticks of can ends being deposited in the lanes at the inbound staging area. Moreover, the controller also determines a cumulative outbound rate which is the rate at which sticks of ends are being withdrawn from the outbound lanes of the outbound staging area. The transfer head moves one group or stick of ends at a time and removes sticks from the inbound staging area at a first pick up rate equal to the cumulative inbound rate. The transfer head also places

-4-

sticks of can ends in the outbound staging area at a placement rate equal to the cumulative outbound rate. The controller and apparatus balances the pick up rate with the placement rate by directing the transfer head to  
5 additionally transfer a sufficient number of groups to and/or from storage so that a desired regulated flow is achieved or maintained by the overall operation.

In accordance with this apparatus, the storage tray conveyor and respective magazines permit continuous  
10 regulated flow to occur even when one of the work stations is experiencing interrupted operation for any time period. In a start-up sequence, for example, a supply of empty storage trays equal to a maximum number of trays that can be handled by either of the magazines is loaded into the empty  
15 tray magazine. The transfer head is programmed to load each stick of can ends arriving at the inbound staging area into a receptacle portion or trough in a storage tray. Accordingly, a first empty tray is deployed from a stack of empty trays in the empty tray magazine onto the horizontal  
20 crossfeed conveyor. The tray is moved to the transfer station and then indexed therethrough as the transfer head places sticks of can ends one stick at a time into a receptacle trough portion. This series of steps is repeated until all of the receptacle portions of the storage tray are  
25 filled. Thereafter, the filled tray is moved by the conveyor to the filled container magazine. At the filled container magazine, a lift engages the bottom of the filled storage tray and raises it to an extended position. Thereafter, side mounted holder fingers are actuated to an  
30 inwardly extended position wherein the fingers are located under the edges of the raised storage tray. The holder

-5-

fingers may also be actuated to a retracted position out of the path of the lift area. Once the trays have been shifted and the holder fingers have been moved to their inwardly extended position under the stack of filled storage trays, the lift mechanism is lowered until the lowermost tray rests on the extended holder finger supports in a raised and stored position within the filled container magazine spaced above the crossfeed conveyor. This start-up sequence is repeated until a desired number of trays are filled which are loaded into the filled tray magazine.

In accordance with the apparatus and method described in this patent, a fixed number of storage trays may be shuttled back and forth between the filled container magazine and the empty container magazine, as required in operation. The apparatus described in US 4,808,057 was designed for use in can end manufacturing systems having operating rates of between about 2,000 to about 5,400 or more ends per minute. Typically, ends are stamped in a stamping press and are then passed through curl wheels to impart the curled peripheral lip portion. Good operating rates with these systems are generally from about 2,500 to 4,000 ends per minute.

More recently, advances have been made in the stamping and forming operations. More particularly, new and improved end die presses have been developed which stamp the can ends from rolled and sheet stock and simultaneously provide the peripheral curled lip portion in a single or dual stroke of the stamping die. These newer die curl presses are running at 250 strokes per minute and are expected to be able to perform at rates of 300 to 350 strokes per minute in the future. In this modern

-6-

manufacturing context, a typical die may produce as many as 28 can ends for each stroke and at an operating rate of 300 strokes per minute, the modern stamping operations are expected to be producing at least about 8,400 can ends per  
5 minute.

This four-fold increase in production rate must be matched or accommodated by the operating rates and capacities of either the related workstations or the automated workload balancers required between workstations  
10 in the production line. Pressure to improve the operating rates of each successive workstation has also been prompted by this improvement in stamping operations. The balancer described in the above-mentioned patent and patent  
15 application has a practical upper limit of about, an operating rate of about 5,400 ends per minute, which rate is insufficient for more modern manufacturing operations.

More recently an improved, high capacity workload balancer apparatus has been introduced which is described in copending commonly assigning US application Serial No.  
20 550,476, filed July 10, 1990, now abandoned. The new and improved balancer apparatus described in this application achieves increased transfer rates by a modification of the transfer mechanism and its movements. Instead of having a storage tray being indexed under a central location of a  
25 transfer station to present one article stick receiving trough at a time to the transfer head, a storage tray is positioned in parallel side by side relation to the inbound lanes, the outbound lanes, or both, within the operating range of motion of the transfer head. In accordance with  
30 this modification, the transfer head can move overhead to any designated lane and to any designated trough positioned



-7-

at the transfer station. In addition to increasing the rate of transfer with the more flexible movement capability of the transfer head, the balancer described in this application includes an increased capacity storage facility.

5 More particularly, at least one elevator module is provided having a shaft extending through the transfer station. A pallet of trays may be advanced on demand to the elevator shaft and one tray at a time may be presented through the transfer station. When an entire pallet of trays is filled

10 up or emptied, the pallet is advanced out of the elevator shaft to a pick up area. A fork lift operator may remove a pallet of filled storage trays out of the line at this point if necessary. In accordance with this aspect of the invention, the improved balancer includes a pallet/elevator

15 subassembly arrangement which manages groups of groups trays for increased storage capacity. The earlier conveyor/magazine storage arrangement generally managed a single group of trays at a time. The higher capacity balancer equipped with a dual transfer head and dual

20 elevator system is rated at speeds above about 6,000 to about 8,000 articles per minute or more. The pallet and elevator systems however are relatively expensive and undesirably increase the cost of the overall balancer apparatus.

25 Accordingly to further improve upon the prior art automated balancers, it is an object of the present invention to provide a new and improved automated workload balancer apparatus capable of accommodating operating rates above about 5,000 articles per minute and preferably between

30 about 7,500 to about 10,000 articles per minute at a reduced overall cost.

-8-

It is another object of the present invention to provide a new and improved automated workload balancer having an improved transfer station and transfer mechanism including an increased number of lanes and a new and improved transfer head assembly having an expanded range of reciprocal movements within the larger transfer station.

It is a further object of the present invention to provide a new and improved high speed and high capacity balancer apparatus capable of maintaining the articles to be moved in a desired transfer orientation and configuration.

#### SUMMARY OF THE INVENTION

In accordance with these and other objects, the present invention provides a new and improved automated workload balancer for automatically regulating a flow of articles between a first work station whereat a plurality of strings of articles are produced at a first variable cyclic operating rate, and a second downstream work station whereat an operation is performed on said plurality of strings of produced articles at a second variable cyclic operating rate, such that at least one of said work stations may continue in uninterrupted operation and at a desired operating rate when the rate of operation of the other work station is temporarily varied or interrupted.

The automated balancer comprises a transfer station, which may generally be considered to be a raised elongate horizontal planar location having a longitudinal axis extending parallel to the floor upon which the apparatus rests. An inbound staging area is provided at the transfer station, whereat a plurality of pre-formed groups of said produced articles, e.g. sticks of can ends, are

-9-

temporarily accumulated prior to transfer. The inbound staging area includes a plurality of inbound lanes, each lane being adapted to receive a succession of the aforesaid groups of articles.

5           The apparatus also includes an outbound staging area at the transfer station. The outbound staging area is the area at which groups of produced articles are temporarily accumulated prior to advancement to the downstream or second work station. The outbound staging  
10 area is also defined by a plurality of outbound lanes, with each lane being adapted to receive a succession of the groups or sticks of articles.

          At least one storage tray load/unload area is also provided at the transfer station adjacent the inbound  
15 staging area, the outbound staging area, or preferably both. A transfer head is provided at the transfer station which includes means for gripping and releasing a group or stick or articles. In accordance with this invention, the transfer head is positioned above the areas of the transfer  
20 station and is independently reciprocally movable along a longitudinal axis extending parallel to the longitudinal axis of the transfer station. The gripping and releasing means on the transfer head includes gripping jaws which are reciprocally movable in a vertical direction, including a  
25 lowered or extended position at the transfer station and an upwardly retracted or raised position spaced above the transfer station. The transfer head and gripping jaws are free to travel above the lanes extending along the longitudinal axis of the transfer station including the  
30 lanes at the inbound staging area, the lanes at the outbound staging area or the extra lanes formed by the stick

-10-

receiving receptacle groove portions defined in each storage tray when the storage tray is in its load/unload position at the transfer station.

In accordance with this invention, the apparatus  
5 includes at least one modified magazine and conveyor storage subassembly. The storage subassembly or arrangement includes a plurality of storage containers or trays, each container have a plurality of storage areas or troughs for receiving a plurality of being-manufactured articles arrayed  
10 in individual groups. A magazine for receiving a plurality of containers filled with articles and a magazine for accommodating or receiving a plurality of empty containers are provided.

The storage arrangement further includes means for  
15 positioning one container being filled or emptied to a load/unload position in the transfer station so that the containers may serve as a variable capacity transient storage area for the purpose of balancing inbound and outbound quantities of the articles. Preferably, the groups  
20 of articles form an elongate stick or group having a given or pre-determined length dimension. In accordance with this invention, a container conveyor means is provided for reciprocally moving a container from the empty tray magazine, into the transfer station, and thereafter, from  
25 the transfer station into the filled tray magazine. Preferably, each of these conveyor stops are linearly aligned along a conveyor axis which preferably extends generally perpendicularly with respect to the longitudinal axis of the transfer station. Moreover, the storage  
30 containers are conveyed along the conveyor axis so that the axial length dimension of a stick receiving trough or a

-11-

stick of articles placed therein is parallel the longitudinal axis of the inbound and outbound lanes and disposed generally perpendicular with respect to the longitudinal axis of the transfer station. In a preferred embodiment, a storage container conveyor/magazine assembly is provided at each of the opposite ends of the transfer station, adjacent the inbound lanes and the outbound lanes, respectively. As has already been mentioned, the transfer head is capable of moving along the entire length of the longitudinal axis of the transfer station from one magazine/conveyor assembly across the inbound and outbound lanes to the other magazine/conveyor assembly.

In accordance with an especially preferred embodiment of the apparatus, the inbound lanes and the outbound lanes are each provided with article management means for maintaining the articles in a given stick in a proper orientation and configuration for transfer. More particularly, in accordance with this preferred embodiment, holder means and pusher means are provided in each of the inbound and outbound lanes to prevent article fall-over or other article misplacement which may foul a lane. Preferably, the infeed and outfeed lanes are angled with respect to the floor upon which the balancer rests and with the horizontal plane of the transfer station, so that the influence of gravity may be relied upon in part to prevent the leading portion or trailing portion of each stick of articles from falling over or becoming misaligned or disoriented with respect to the other articles of the stick or the lane along which the stick is being advanced.

In accordance with this preferred feature, means are provided along the infeed lanes to push the articles up

-12-

hill or against the influence of gravity along the path of advancement into the inbound staging area and means are provided for holding each stick in each lane at its opposed ends at the staging area to maintain all of the articles and especially the end most ones in a given stick in proper stick configuration for transfer. Similarly, in the outfeed lanes, means are preferably provided to guide the articles downhill in the direction of the influence of gravity along the path of advancement until a consolidation unit rejoins successive sticks to reform a string of articles for transfer to a downstream workstation.

In accordance with the new and improved balancer operation, a plurality of strings of stamped and formed can ends or other manufactured articles are fed from the first work station toward the inbound staging area in plural inbound feeder lanes. A leading portion of each string in each inbound feeder lane is subdivided to define a group or stick of can ends or articles from the remainder of the string. The leading portion may be subdivided by successively counting off a predetermined number of articles or by successively measuring a predetermined leading length along the string of articles to form the stick.

Each group of articles is separated from the remainder of the inbound string by advancing the group to the inbound staging area as the next succeeding group is being formed. A detector and controller means continuously determines a cumulative inbound rate equal to the rate at which successive groups in the plural lanes are being advanced into the inbound staging area.

The transfer head is used to remove groups of articles from the inbound staging area, one lane at a time,

-13-

at a pick-up rate substantially equal to the cumulative inbound rate. The transfer head is also used to transfer groups of articles, one group at a time, to an outbound lane in said outbound staging area at a placement rate. Article  
5 groups are withdrawn from the outbound staging area by moving each group along an outbound lane to said second downstream workstation, the moving step includes the step of consolidating successive groups to re-form a string of articles in each outbound lane.

10

A cumulative outbound demand rate is monitored and determined in the apparatus which is equal to the rate at which groups of articles must be withdrawn to provide a sufficient supply of articles to maintain a desired rate of  
15 operation at the second work station.

The transfer rate is adjusted so that the placement rate is substantially equal to the outbound demand rate. The balancer control balances the pick-up rate with the placement rate by directing the transfer head to  
20 additionally transfer a sufficient number of groups to and from a storage tray, so that the desired regulated flow is achieved.

Other objects and advantages provided by the present invention will become apparent from the following  
25 Detailed Description of the Drawings in which:

**BRIEF DESCRIPTION OF THE DRAWINGS**

Fig. 1 is a perspective view of the preferred high speed/high capacity balancer apparatus of this invention which is specially adapted for use in regulating the flow of  
30 can ends in a modern can making manufacturing operation.

Fig. 2 is a top plan view of the preferred

-14-

balancer apparatus shown in Fig. 1;

Fig. 3 is a side elevation view of the balancer apparatus, taken along view lines 3-3 in Fig. 2;

5 Fig. 4 is a side elevation view, partly schematic in nature, of the new and improved angled infeed arrangement in accordance with the preferred embodiment and showing a string of can ends being urged along an infeed lane;

10 Fig. 5 is a side elevation view similar to Fig. 4, and showing the beginning operation of subdividing a predetermined length of ends to form a stick from the remainder of the string;

15 Fig. 6 is a side elevation view similar to Figs. 4-5, which shows the subdivided stick of ends in an advanced and separated position wherein the ends are received below the inbound staging area in a pivotable end segment of inbound track or lane;

20 Fig. 7 is a side elevation view similar to Figs. 4-6 showing the holder finger elements of the rotatable track segment in an extended holding position to positively hold the endmost can ends of the stick for further transfer.

25 Fig. 8 is a side elevation view similar to Figs. 4-7 showing the separated and gripped stick ends rotated by the track segment up into the inbound staging area awaiting pick up by the transfer means;

Fig. 9 is a front elevation view of the preferred balancer apparatus shown in Figs. 1-2;

30 Fig. 10 is a side elevation view of the preferred balancer apparatus showing the gripping and releasing means of the transfer head as well as a preferred conveyor/magazine storage assembly in greater detail;

Fig. 11 is a side elevation view similar to Fig.



-15-

10 with portions of the transfer means omitted showing an  
empty storage tray deployed from the empty tray magazine  
onto the storage tray conveyor and a filled storage tray at  
the load/unload position at the transfer station awaiting  
5 rightward conveyor advance, as shown, to position the filled  
tray within the filled tray magazine area and the empty tray  
within the transfer station;

Fig. 12 is a side elevation view of the preferred  
outbound discharge assembly for use in the new and improved  
10 balancer apparatus showing a rotatable track segment  
comprising a part of the outbound staging area lanes in a  
lowered position with the discharge guide jaws shown closed  
against the leading can end of the stick with the discharge  
guide jaws upper position;

15 Fig. 13 is a side elevation view of the preferred  
outbound discharge showing the discharge guide jaws  
advancing the stick of can ends along the outbound lane to  
catch up to the last end of a previous stick of ends leaving  
the balancer apparatus;

20 Fig. 14 is a side elevation view similar to Fig.  
13 showing the discharge guide jaws in their lowermost and  
opened condition so that the stick of ends is guided in the  
outbound lane under the influence of gravity until it slants  
against the last end of a previously discharged stick of  
25 ends to reform a continuous outbound string of articles  
being advanced to a downstream work station and showing the  
rotatable track segment of the outbound staging lane in its  
raised position awaiting deposit of another stick of ends  
from the transfer head;

30 Figs. 15-23 are side elevation views of the  
storage magazine/conveyor assemblies illustrating the

-16-

sequential operating steps of raising the lift platform in the empty tray magazine until the lowermost tray of the empty tray stack is contacted, retracting the tray support fingers while lifting the entire stack of empty trays, lowering the lift platform an incremental amount and reinserting the tray support fingers under the lower surface of the second tray and between the lowermost tray and the second next to the lowest tray, lowering the platform until the lowermost tray is deposited onto the conveyor assembly, advancing the empty storage tray rightwardly into position in the load/unload area in the transfer station for filing one receptacle or trough area at a time until the tray is filled, advancing the filled tray further rightwardly into position in the filled tray magazine, raising the lift platform and filled tray upwardly off the conveyor until the filled stack of trays is contacted, lifting the entire stack of filled trays while retracting the tray support fingers until the newly filled tray is disposed above the tray support fingers and re-inserting the tray support fingers inwardly and lowering the lift platform until the stack of filled trays is again supported above the conveyor in the filled storage magazine, respectively.

Figs. 24-26 are side elevation views showing an alternate guided discharge assembly for use in the new and improved balancer apparatus of the invention;

Fig. 27 is an enlarged side elevational view of a part of the separator/accelerator unit with portions broken away, and with other portions in section, showing parts of the integrated mover unit, certain elements of the splitter mechanism and the separator advancer mechanism used to subdivide the continuous array of incoming articles into

-17-

individual groups;

Fig. 28 is a side elevational view, partly diagrammatic in nature, and showing further details of the operation of the separator mechanism used to subdivide the  
5 articles into groups;

Fig. 29 is a vertical sectional view of the integrated mover unit of Fig. 27, taken along lines 29-29 thereof;

Fig. 30 is an end elevation view of the splitter  
10 and separator acceleration jaws of the infeed advance mechanism taken along view lines 30-30 in Fig. 27;

Fig. 31 is a side elevational view of the article group transfer means of the apparatus, including the pick-up  
head;

Fig. 32 is a vertical sectional view of the pick-up head and head positioner of Fig. 31, taken along lines  
15 32-32 thereof;

Fig. 33 is an enlarged vertical sectional view, with portions broken away, showing portions of the container  
20 support elements and the support finger drive mechanism in the magazines;

Fig. 34 is a vertical sectional view of the drive mechanism taken along view lines 34-34 in Fig. 33;

Fig. 35 is an enlarged view, partly in elevation/partly in section, showing elements of the container  
25 support system and the storage container conveyors in each of the magazine assemblies;

Fig. 36 is a top plan view, schematic in nature and showing the use of the balancer in a can manufacturing  
30 operation wherein the articles being manufactured are easy-opening can ends.

-18-

DETAILED DESCRIPTION OF THE INVENTION

Referring now to Fig. 36, a schematic illustration of the end forming processing operation is illustrated. As depicted in Fig. 36, a coil of sheet metal stock is stamped in a shell press area to form a plurality of can ends. The can ends are fed from the shell press into a string former which forms them into a continuous string of ends which is fed along inbound feeder lanes into an inbound staging area of the new and improved workload balancer 10 of the present invention. The workload balancer 10 first separates sticks of articles from the incoming string feed and advances them into an inbound staging area of a transfer station. A plurality of lanes for receiving outgoing sticks of articles is provided in an outbound staging area within the balancer device. These ends are accelerated out of the outbound staging area through a string reforming mechanism to form continuous string of can ends which are fed to a liner or other second work station. The lining or secondary work station applies a curable resin composition to the inside of the lid for sealing it to the bottom portion of the beverage can and subsequent operations.

In accordance with the present context, the balancer 10 must continuously determine the cumulative inbound rate at which can ends are being advanced from the shell press area into the workload balancer. It must also determine the demand rate out required to keep the end liner secondary work station functioning and it must meet the demand out by placing sticks of can ends in the outbound lanes and advancing them from the outbound staging area into the outbound feeder lanes. Any difference between the cumulative inbound rate and the outbound demand rate must be

-19-

made up in the workload balancer by directing the transfer head to transfer sticks to or from storage to put additional sticks or groups of articles for placement into the flow of the system to keep both Workstation 1 (stamping) and Workstation 2 (lining) operating at their respective desired rates. As shown in Fig. 36, after the liner operation, the ends may be dried and reformed into strings for feeding into a secondary workload balancer 10a in preparation for sending them on their way to a third workstation whereat conversion presses add score lines and pull top tabs to the can ends before they are subsequently stored for future use.

From the foregoing explanation it will be seen that one general object of the invention is to provide apparatus and methods for insuring that the various work stations may be operated at their full instantaneous production capacities without creating supply or demand problems at the individual work stations. This is done, in simplest terms, by determining the respective rates of supply and demand for the articles, and transiently placing in storage, or taking from storage, groups of articles sufficient to supplement or diminish the rate at which articles passing through the load regulators would be supplied directly from the inbound to the outbound lanes or staging areas. If supply and demand are evenly balanced, articles are transferred in groups from the staging areas fed by the inbound lanes to staging areas adjacent the outbound lanes, without change of the inbound and outbound rate relative to each other. If not, articles are placed in or taken from storage to achieve matching of rates and regulation of workload.

A transfer from inbound to outbound may be thought

-20-

of, or described as, "direct" even though it may be achieved with one or more intermediate or "idler" steps. By "direct" is therefore meant the condition wherein the inbound and outbound rates are the same and normally this means without  
5 intervening withdrawal of articles from the inbound areas or addition of articles to the outbound areas to or from storage.

Referring now to Fig. 36 and Figs. 1-3, other principal components of the invention are shown, and these  
10 include an elongate transfer station 12 with an overhead transfer mechanism 14 which is movably positionable relative to the framing 16 forming a part of the transfer station 12. The preferred apparatus 10 also includes a pair of storage conveyor/magazine subassemblies 18 and 20. Left and right  
15 subassemblies 18 and 20 each include magazine 22, 24 for empty trays and a magazine assembly 26, 28 for full trays. The infeed mover 30 and the outfeed consolidation assemblies 32 are shown to communicate respectively with an inbound staging area 34 and an outbound staging area 36. Staging  
20 areas 34 and 36 are shown in greater detail hereinafter.

Storage deposit and retrieval areas 38 and 40 are shown to lie at the opposed ends of the transfer station 12, outwardly of the inbound staging area 34 and the outbound staging area, respectively. Figs. 1-3 also show the  
25 preferred angled infeed unit 42 and angled outfeed discharge unit 44 of the preferred embodiment. The angled infeed unit 42 generally includes a plurality of infeed lanes 46 from an upstream workstation, each lane including roller mover 30, an inclined feeder track 48 equipped with a rotatable track  
30 segment 50 at an upper end thereof and each lane having an accelerator/separator assembly generally designated 52.

-21-

Separator units 52 are provided for subdividing a continuous array or string 54 of can ends or other articles 56 advancing in each inbound lane 46 and 48, for example, into individual groups or sticks 58.

5           A hydraulic piston and cylinder type lift unit generally designated 60 is shown to be provided and to form a part of the empty tray magazines 22, 24; a counterpart lift 62 is provided for the full tray magazines 26 and 28.

10           The angled outfeed area or unit 44 includes a plurality of inclined outfeeder tracks 64, each including a rotatable upper track segment 66 for connecting the outbound staging area lanes 36 to string conveying outbound lanes 68. The outfeed consolidator unit 32 is disposed at the lower end of the outfeeder tracks 64. An outfeeder guide jaw mechanism 70 adjacent each outfeeder track 64 is provided to  
15           guide each stick of articles downhill in a controlled manner to the outfeed consolidators 32. The outfeeder guide jaw assembly 70 works in the opposite sense as the accelerator/separator assembly 52, insofar as the latter  
20           subdivides continuous strings 54 of articles into article groups 58 and, in the latter, the outfeeder jaws and consolidator 70 and 32, assemble groups 58 back into continuous strings 54, or permit sticks 58 to accumulate  
25           into continuous strings 54, for feeding into the associated outbound conveyor lanes 68 for travel to a downstream work station.

          The transfer apparatus 14 which, in one mode, picks up sticks of articles 58 from the inbound staging area 34 and deposits them either in a storage container 72  
30           positioned at the left or right hand storage and retrieval areas 38 and 40, or in the outbound staging area 36, and in

-22-

another mode, picks up sticks of articles 58 from a container 72 in either deposit and retrieval area 38 or 40 and deposits them in the outbound staging area 36 for passage to the outbound lanes 68.

5           The transfer apparatus 14 is disposed overhead and adjacent the inbound staging area 34, the outbound staging area 36, and the deposit and retrieval areas 38 and 40. In addition, details are shown of the storage container in the form of individual trays 72, each having receptacle trough areas 74 for the sticks of can ends 56. A cross feed container conveyor generally designated 76 is provided for positioning individual storage trays 72 during loading and unloading. Additional details of the angled infeeders 42, outfeeder units 44 and the cross feed tray conveyor/magazine assemblies 18-20 are set forth below.

10           Referring now to Figs. 27-30, the principal components of the angled infeeders 42 include a plurality of guiding rails or tubes forming the inbound lanes 46 for directing a plurality of inbound articles, in this case, can ends 56, which are in nested, face-to-face relation toward the balancer apparatus 10. Adjacent the innermost or downstream ends 78 of the guide units 36 are a plurality of so called integrated mover units 30, details of which are shown in Figs. 27-29. The foregoing and other elements are mounted at an angle on an accelerator/separator machine frame generally designated 80.

25           The accelerator/separator 52 includes a plurality of group or stick forming assemblies each generally designated 82, plural group transport assemblies generally designated 84, and plural transport actuator assemblies generally designated 86. Since the articles being fed are

30



-23-

can ends 56, the inclined feeder tracks 48 and rotatable track segments 50 in the accelerator/ separator 52 are in the form of semi-circular channels 88 disposed parallel to one another. As shown in Figs. 7-8, rotatable track segments 50 each include a forward stop 100 at one end thereof extending into the transfer station below the transfer mechanism 14. Reciprocable stop fingers 102 adapted to extend upward into the channel 88 adjacent a free end 104 of rotatable track segment 50 to hold the last of the can ends 56 of a stick of ends 58 are disposed in track segment 50. Rotator means 106 in the form of a piston/rod and cylinder assembly may be provided to move the rotatable track segment 50 from an angled lower position (Fig. 7) to a raised horizontal position (Fig. 8) under the transfer head 14.

The rotatable segments 50 beneath the cross frame 16 in their raised horizontal position may be referred to from a functional standpoint as inbound staging areas or lanes 34, and these areas are defined by fixed stop units 100 for the leading article 56 in the group 54 and movable stop fingers, generally designated 102, for the trailing article in the group 54. The fixed stop units 100 normally have associated therewith a detector 108, such as a light beam and photoelectric cell arrangement to indicate that a group 54 is in the channel 48. A stick length sensor 110 and an overload sensor 112 are provided at the upper end portion of inclined feeder tracks 48. As will appear, a measured stick length of articles may be advanced, supported and maintained in a group by being held between the fixed and movable stops 100 and 102.

Fig. 28 shows that each of the ends 56 has a

-24-

countersink wall 114 which permits nesting of the ends as a whole. This wall 114 and the curl forming the top of the end are gripped by the working surfaces, thereby aligning the ends vertically. The ends nest relative to one another, and hence do not readily fall forward or backward from the group; therefore, assuming that they are kept relatively close together axially. Pushers for the groups of ends exert an axial compressive force on the group of ends.

Referring to Figs. 27-30, the infeed mover assembly 30 and the accelerator/separator units 52 are shown.

Each of the stick forming accelerator/separator assemblies 52 includes a vertically reciprocable string divider blade 120 adapted to engage a leading edge of the ungrouped array 54 of ends 56 to transiently prevent advancement of the remainder of the string 54. This blade 120 and its associated elements cooperate with means in the form of an opposed pair of knife edges on accelerator jaws 122, 124, arranged on a scissor mechanism generally designated 126. When the stick length sensor 110 senses the leading end of a string in the inclined feeder track 48, the blade 120 moves vertically in response to a length signal, and thus begins the process of dividing the ungrouped array 54 into a leading and a trailing group. Immediately thereafter, the accelerator jaws 122 and 124 move inwardly to engage the trailing edge of the last article 56 in the group lying downstream of the blade 120. The immediately successive operations of the vertical blade 120 and the closable jaws 122, 124 ensures that the division between leading and trailing articles is made cleanly, and that both sides of a single article 56a are engaged, rather than sides

-25-

of adjacently disposed articles, which might create tilting and mis-feed.

Referring now to the scissor mechanism 126, this will be seen to include left and right hand bell crank arms 128, 130, which are mounted on pivot pins 132, 134. An air cylinder 136 positioned by a yoke 138 and containing an operating rod 140 is able to move a clevis pin 142 through a short vertical range of movement. This pin 142 is disposed in slots 144, in the inner margins of the crank arms 128, 130. Consequently, upon a signal generated by the stick length sensor 110, the pneumatic cylinder 136 may be actuated, and the jaws 122, 124 rapidly move radially inwardly and engage the trailing surfaces of the trailing article 56a to form an article group 58. As shown in Fig. 30, the yoke 138 is in turn positioned on a carrier element 146 forming a part of the accelerator transport mechanism 148 described herein.

Referring again to Fig. 30, will be noted that the upper "pre-splitter" or vertically reciprocating blade 120 is also operated by a pneumatic cylinder generally designated 150 and containing an operating rod 152 which terminates at its lower edge in a holder 154 for the blade 120.

Referring now in particular to Fig. 30, the operation of the accelerator transport actuator 148 will be described. In this connection, will be understood that the actuator 148 is only one of a group of substantially identical actuators used to operate various mechanisms of the invention. The actuators of the type presently preferred for use in the present invention are of a type known as "Tol-o-matic" cylinders which are made by the Tol-

-26-

o-matic Company of Minneapolis, Minnesota and whose operation is known to those skilled in the art. The following general description therefore is made for ease of understanding and is primarily schematic.

5 Referring now to the lower part of Fig. 27., the actuator assembly 148 includes a housing generally designated 156, having an interior cylindrical side wall 158 which positions a reciprocating piston 160 having one end of a continuous metal tape 162 attached to each of its end  
10 faces. The tape 162 is trained over a rotary, fixed axis guide roller 164 positioned in an end cap 166 for the interior chamber 168 or cylinder 158.

The actuator 148 also includes a seal 170 for retaining air within the interior cavity 168 of the cylinder  
15 158. The other ends 172 of the tape 162 are affixed to either end of the carrier 146. The carrier 146 includes a cover unit 178 having guide ears 179 received in longitudinally extending guide slots 176 on the exterior of the unit 148. Consequently, in operation, when either end  
20 of the cylinder is pressurized, the piston 160 will move in the opposite direction, moving the tape 162 over the roller 164 and causing the carrier unit 146 to move atop the housing 178 in the opposite direction. A series of Commercial units normally include a series of protective  
25 covers or casings for the tape and appropriate keyways or like arrangements generally shown in Figs. 27-30 are usually provided for this purpose.

Referring now to Figs. 31 and 32, various construction and operational details of the transfer  
30 mechanism 14 and its pick-up head 180 of the invention are shown. The pick-up head 180 is of a generally known type,

-27-

such as that referred to for example in U.S. Patent No. 4,808,057. However, this head has been modified somewhat for the purpose of the present invention and is therefore shown in detail here.

5           The transfer head mechanism 14 includes the cross frame 181, which serves to mount a pick-up head generally designated 180. A motor (not shown) and its associated control and gear drive, actuate a toothed belt drive 248, which accurately indexes the pick-up head assembly 180 over  
10 a desired trough or lane in the staging areas or storage deposit and retrieval areas. Two longitudinal guide rods 16 have bushings 17 with eyes which align the pick-up head assembly 180 and position it for reciprocable movement in use. Fig. 31 shows additional construction and operational  
15 details of the pick-up head mechanism and related components.

          Basically, the pick-up head assembly 180 includes a pick-up head frame 195, means for moving the head 180 transversely over the lanes at 34, 36 and at areas 38 and 40  
20 which the sticks of articles 58 are received, and means for moving the head vertically, means for removing the ends or other articles once gripped, and means for securing the ends against falling from the end of the assembly unit 180.

          Fig. 31 shows not only the pick-up head frame  
25 generally designated 195, but the arrangement of the movement and guide systems. Thus, the head 180 includes a mounting bracket 182 having an eye 184 therein for receiving mounting pin 186. The pin 186 is disposed in a lower portion of an operating rod 188 extending from the lower end  
30 of a piston and cylinder assembly generally designated 190. According to the invention, the double acting piston and

-28-

cylinder assembly 190 causes vertical reciprocation of the bracket 182 and the head 180 carried thereby.

In order to insure appropriate vertical movement in an aligned relation, left and right hand identical guide rods 192, 194 are received in suitable bearings 196, 198 provided in the frame. The lower ends of the guide rods 192, 194 are pinned, as at 200, 202 to two stub mountings 204, 206 on the top frame 208 of the pick-up head 180.

Referring to Fig. 32, it will be noted that on the interior of the head assembly 180 there is disposed a longitudinally extending, inverted V-shaped channel unit 210, which is secured to an associated knock-out cylinder 212 at plural, spaced apart points by a rod 214. Actuation of the cylinder 212 moves the support rod 214 vertically, pushing the ends or other articles therein downwardly relative to the frame 208. As is shown in Fig. 32, articles such as the ends generally designated 56 are retained in place by the radially slightly inwardly directed lower margins 216, 218 of sidewalls 220, 222 of the pick-up head 180.

In the preferred form of unit, these sidewalls 220, 222 are made from a plastic material, such as a LEXAN® polycarbonate plastic material having a strong elastic memory. In use, the sidewalls 220, 222 deflect slightly outwardly when the head 180 is received over a fixed column or group of ends or other articles, and are thus simply press fit into the article receiving area 224 in the pick-up head 180.

The innate resiliency of the sidewalls 220, 222 is sufficient to confine the articles 56 until they are forcibly removed by actuation of the cylinder 212 and the

-29-

rod 214. One cylinder piston and rod assembly 212, 214 is described in detail; its counterpart generally designated 226 in Fig. 31 will be understood to be identical and is therefore not described in detail herein.

5 Referring again to Fig. 31, there is shown a pair of substantially identical, left and right hand end clip assemblies 226, 228 respectively. Each of these is intended to position an apertured end plate 230 by means of an arm 232 to retain ends within the pick-up head 180. The end  
10 plate 230 preferably includes a semi-circular recess 234 permitting it to fit over the end of stop finger 100 on the rotatable infeed track segment 50 in its raised position in the transfer station 12.

Fig. 31 shows the left hand mechanism 226 in the  
15 open position, toward which position it is schematically shown to be biased by a spring 236. Upon generation of a proper signal, the control cylinder 238 is actuated pneumatically, urging the operating rod 240 vertically until it engages the lower surface of the pivot arm 232. Further  
20 movement causes the arm 232 and the end plate 230 to rotate about the axis of the pivot pin 242, thus positively retaining the ends 56 within the pick-up head 180. Fig. 32 also shows that clamps 244, 246 are used to secure the free ends of the drive belt 248 to the movable head 180.

25 Hence, it is apparent that in operation, when it is desired to position the upper frame 250 such that the head 180 is aligned with a given lane 34, 36, 38 or 40, the control (not shown) is actuated and the drive motor (not shown) moves the belt 248, stopping the unit 180 just above  
30 the desired lane in the staging areas. A D.C. motor drive of a known type is suitable for this purpose.

-30-

Thereupon, the cylinder 190 is actuated and the head 180 is lowered fully until the ends are gripped between the sidewalls 220, 222 of the head 180. This is done with the end clamps 226, 228 in the open or extended position. The ends clamp cylinders 238 are then actuated to close the end clamps 226, 228 to manage the respective ends of the stick. The cylinder 190 is then actuated, raising the head 180. The motor pulls the belt 248 until the head 180 is positioned over a trough 74 or an outbound lane 36. Then, the sequence of operation is reversed.

When the head 180 is lowered by the cylinder 190 to place a stick in an appropriate lane or trough, the unloading or discharge cylinder 212 and rod 214 are energized to drop or eject the stick of ends from the pick-up head 180. Next, the pick-up head 180 is moved by the pick up head driver 248 to the next succeeding position over a lane or trough and the cycle is repeated.

As pointed out, the machine, using the stick length memory, and being appropriately programmed for an operating sequence as will be described, is able to determine the particular of lane from which an article groups is to be picked up, and also recalls the appropriate length for each group.

Although not shown in detail, it will be understood that a plurality of incoming arrays of ends 54 in lanes 46 may thus be subdivided into individual groups and handled as will appear; three to ten incoming lanes are presently preferred for use in the load regulator of the invention, although more may be provided.

Referring now to Figs. 1-2, 10 and 15-23, several other principal elements of the invention are shown, and the



-31-

capability of the magazine assemblies 18 and 20 are shown. As shown in Fig. 10, each of the magazine assemblies 18 and 20 include cross feed conveyor 76 for serving to move empty and full trays or storage containers 72 to and from their  
5 respective empty and filled tray magazines 22, 24 and 26, 28.

Referring again to Fig. 10 and 35, and in particular to the storage magazines 22, 26 for empty and filled tray respectively, the empty tray magazine 22 is  
10 shown to include a magazine frame 252 having vertical frame members 254, horizontal members 256, and tray guides 258.

Frame members 254 includes one or more journals 260 for accommodating a continuous chain 262 having pusher fingers 264 thereon and forming a part of the cross feed  
15 tray conveyor 76.

In Fig. 35, an empty tray 72 is shown resting on the conveyor 76 just referred to.

Referring again to Fig. 10, each magazine 22, 24, 26, 28 has an associated tray lift 60 and 62. The lift unit  
20 60 includes a piston and cylinder arrangement 266 operating a tray support frame 268 which engages a tray 72 when raised into a position of contact herewith. The piston and cylinder assembly 266 permits the support frame 268 to be raised at least to and slightly above the level of the drive  
25 shaft 270 of the tray support fingers 272.

Fig. 10 also shows that magazine 26 has a similar lift 62 having a piston and cylinder assembly 266 and a support frame 268 forming a part thereof. Fig. 10 shows that the full tray magazine assembly 26 is the same as that  
30 of its counterpart 22, except that the tray 72 has a plurality of stick ends 58, or other articles disposed

-32-

therein. Magazine 26 has a journaling bearing for the end of the cross feed tray conveyor 76 extending therein. Reciprocable container support fingers 272 are operated by racks 274 which are in turn driven by the pinion gears 276  
5 to provide for reciprocating movement of the support fingers 272 into and out of supporting relation with the lower surfaces of the tray 72, as the tray lift units are raised and lowered.

The tray conveyor chain 262 is moved by a drive  
10 sprocket 278 operated by an electric motor and gear drive 280. This chain type conveyor is conventional in all respects, and is driven intermittently between three distinct positions under the control of the conveyor drive mechanism 280 or otherwise as is known in the art. The  
15 cross feed conveyor movement serves to position the tray 72 so that it is disposed in the empty tray magazines, 22 or 24 in the storage deposit and retrieval areas 38 or 40 or the filled tray magazines 26 and 28 respectively. In  
20 use of the apparatus 10, one tray 72 may be in the process of being removed from a stack of counterpart empty trays in empty tray magazine 22 and placed on the cross feed conveyor 76, as shown, while another, filled tray 72 is being added to the stack of full trays at the opposite end of conveyor in filled tray magazine 26.

25 The storage magazines add to and take from an overhead stack of storage trays in a manner shown by the sequence in Figs. 15-23. More particularly, lift 62 is raised until the surfaces of its corner pieces 282 engage the lower surfaces on the corner pieces 284 of the tray 72  
30 disposed above it. In this position, the lift 62 is prepared to support the weight of the entire stack of

-33-

storage containers. Then, the tray support drive mechanism is actuated, the support fingers 272 are withdrawn horizontally and the entire stack is raised in increments equal to the height of the tray. The support finger drive mechanism is then operated in the reverse or extending mode, so that the support fingers 272 engage the bottom of the lowermost tray 64. Thereupon the lift 62 withdraws to a retracted position and the entire stack is supported until repetition of this cycle, or the reverse cycle. The trays are thus "upstacked" or "downstacked" as indicated.

Referring now to Fig. 35, certain details of the cross feed or tray conveyor 72 are shown. Here, a plurality of shafts 304, 306 are shown to carry drive sprockets 308, 310 over which are trained conveyor chains 262. The framing members support brackets on which a plurality of tray rests are secured. These tray rests engage the undersides of the trays and may be made from a block of solid, lubricous plastic material such as a polyethelene or TFE (tetrafluoroethylene) material permitting the tray to slide therealong with minimum friction. The trays are actually advanced by being engaged by the pusher fingers 264, which are in turn affixed to and spaced apart on the conveyor drive chain 262.

The intermittent bi-directional operation of the conveyor drive chain is also accomplished with the aid of proximity sensors or other suitable controls to provide precise indexing and alignment for the motor mechanism 176, 178.

Referring now to Figs. 3 and 4-8, the operation of the preferred angled infeed subassembly 42 are shown. A similar angled outfeed or discharge unit 44 is shown in Fig.

-34-

3. More particularly and referring now to the sequence of operation depicted in Figs. 4-8, in Fig. 4 a continuous string 54 of can ends 56 is fed along infeed lanes 46 extending from a high speed stamper apparatus. The continuous string of can ends is directed through infeed mover unit 30 and is urged along the upperwardly angled inclined feeder track 48 towards the transfer station. The angle of elevation for the inclined feeder track may be varied widely. Preferred angles can include 30 degree angle of elevation or 45 degree angle of elevation. The angle should provide a steep enough slope to prevent the leading can ends of a being formed stick from falling over forwardly during a transfer operation.

As shown in Fig. 4 as the leading end of an advancing continuous string 54 of can ends is urged upwardly along the inclined feeder track 48 towards a stick length sensor 110. In the starting position shown in Fig. 4, the rotatable upper track segment 66 of the inclined feeder track is in a lowered angle position with respect to the transfer head and transfer station so that it forms a smooth continuation of the inclined feeder track 48. The upper right-hand end of the rotatable track segment 50 includes a stick sensor 310 as well as the forward stop finger 100. A pivoting mounting is provided adjacent the transfer station. The rotatable track segment forms the inbound staging lanes 34 of the transfer station when they are rotated to their upward position. In the starting position shown in Fig. 4, the infeed accelerator jaws and splitter jaws are shown in their open condition at the left-hand portion of their "Tol-o-matic" cylinder tape.

Referring now to Fig. 5, as the leading edge of

-35-

the continuous string of can ends is urged by the infeed mover along the inclined feeder track 48 until the leading most can end is sensed by the stickling sensor 110. Thereafter, the accelerator/ separator assembly is activated causing the splitter blade to be introduced into the string of articles to define a leading most group. The accelerator jaws close about the last can end in the stick being formed as shown in Fig. 5.

Referring now to Fig. 6, the "Tol-o-matic" cylinder has been activated and the accelerator jaws have been moved along the tape path to accelerate the group subdivided and formed towards the rotatable track segment located in the upper right-hand portion of the angled infeed track. The separator blade has again been retracted to permit the continuous string of can ends to resume its inward urging by means of the infeed mover shown at the lower left-hand portion of Fig. 6. In its fully extended rightward position as shown in Fig. 6 and 7, the separator/ accelerator jaws have moved the stick of string ends upwardly and rightwardly a distance sufficient to trigger the proximity sensor located in the upper right-hand pivot corner of rotatable track segment 50. In this fully extended position, the leading can end engages the fixed stop finger 100 disposed at the pivotable corner segment. Triggering the stick sensing proximity sensor causes the movable reciprocating holder finger 102 to be extended upwardly through an opening in the bottom of rotatable track number 2 positively engage the last can end being gripped by the accelerator/separator jaws in Fig. 6. Because the accelerator/ separator jaws engage the opposed sides of the can end, the reciprocating holder finger 102 may engage the

-36-

last most can end between these jaws without interfering with the accelerator/ separator jaws return stroke operations. More particularly, in referring now to Fig. 7, the stop finger and reciprocating stop fingers have now been  
5 actuated as shown to positively hold the entire stick of can ends within the rotatable track segment. The accelerator/separator jaws are shown in their open position and the "Tol-o-matic" tape and cylinder for those jaws has been activated to permit the jaws to return to their  
10 original downhill position for recycling.

Referring now to Fig. 8, a means for causing rotation of the rotatable track segment has been activated to raise the held stick of can ends upwardly to assume a horizontal position under the transfer head in the transfer  
15 station. These operations occur while the continuous string of can ends progresses upwardly towards the stick length sensor. If the progressing string of can ends passes the stick length sensor and hits a maximum overflow sensor 112 a signal will be generated to stop the infeed mover 30 to  
20 prevent additional travel of the continuous string along the angled inclined feeder track. As will be appreciated, as soon as the pick-up head of the transfer mechanism 14 has gripped and removed the stick of can ends from the inbound staging lane shown in position within the transfer station  
25 in Fig. 8, sensors immediately create a signal causing the rotatable track segment to be rotated downwardly into its angled infeed position awaiting the next successive group to be accelerated toward the transfer station. The cycle is repeated frequently during operation of the infeed and  
30 balancing operation.

Referring now to Figs. 12-14, the sequential

-37-

operation of the angled outfeed unit 44 is shown. Outfeed unit includes an elongate outfeeder track 64 having a rotatable upper track segment 66 at one end and connecting to outbound lane 68 for carrying re-strung can ends upward to a downstream work station.

5

Once the pick-up head has deposited a stick of can ends into an outbound staging lane for consolidation and transport downstream, sensors initiate the contacting of the last-most can end by a reciprocating holder finger actuated

10 by a piston and cylinder assembly and the outfeed guide jaws 70 are actuated to a closed position. The rotatable upper track 66 of the outfeed track 64 is in its horizontal position with respect to the transfer station. Thereafter, very quickly the rotatable driver means permits the upper

15 rotating track segment 66 to rotate to the downward position shown in solid lines in Fig. 12. In this position, the entire stick of can ends is held under the influence of gravity against the closed outfeeder guide jaws which are similar to the accelerator/separator jaws shown in Figs. 27-

20 30. In the downwardly angled or inclined position, rightward movement of the outfeeder guide jaws 70 slowly permits the stick of can ends in its grasp to be lowered towards the previous end of can ends recently deposited. As shown in Figs. 12 and 13, a pair of sensors are provided

25 adjacent the outfeed consolidated unit including a previous string end positioning sensor and an under flow sensor. As soon as the last-most can end of a previously deposited stick is sensed by the string end sensor, the upper end of the angled outfeed unit is cleared to permit the next stick

30 of can ends to be slid down the inclined outfeeder lanes and released to permit the stick of can ends to add on to the

-38-

last-most can end of the previously deposited stick. The consolidated unit and the outfeeder guide jaw mechanism together form a reconsolidated unit for causing the individual sticks of can ends to be reformed into continuous strings of can ends for further transport and handling to downstream workstations. A stick end position sensor is provided at the lower right hand portion as shown of the rotatable upper track segment 66 which is effective to sense when the stick end has been slid beyond the free end of the rotatable track segment. This generates a signal causing the rotatable track segment to move to its upwardly disposed position shown in Fig. 14 to await placement of a subsequent stick of ends by the transfer head.

In accordance with this invention, the rotatable track segments 50 and 66 may be rotatably pivotally mounted at one end to a pivot pin mounting means and may be caused to rotate between their horizontal and angled extreme positions under the influence of a piston/rod and cylinder arrangement or the rotatable track segments may be fixedly mounted to a rotatable shaft as will be readily apparent to those skilled in this art.

An alternate discharge arrangement is depicted in Figs. 24-36. In accordance with this arrangement, angled discharge lanes are provided having a split center section capable of receiving a pair of upwardly projecting dogs or jaws mounted to a drive chain. Cam rails for opening the jaws are positioned at the lower right hand portion of the angled infeed track at a point located above the string end positioned sensor. Return cam rails for closing the jaws opening during the downhill travel are provided at the upper right-hand portion of the chain path of travel to reclose



-39-

the jaws as they are positioned in the outbound staging lanes preparatory to receiving the next stick of ends from the pick-up head. In the operational sequence depicted in Figs. 24-26, the outbound discharge chain conveyor and jaw system is disposed in a horizontal position with respect to the transfer station. The can end engaging jaws are connected together for concerted opening and closing movements and are shown in their closed position engaging the opposing ends of an elongate string of ends which have been deposited by the transfer head. Sensors sensing the end-most can end in the angled outfeeder lane 64 sends a signal to the conveyor drift shaft which may be a chain sprocket drive mechanism well known to those skilled in the art to begin its cycle rightward and downward along the chain path to manage the ends front and back during its downward travel. As the gripped stick of ends approaches the last end of the previously deposited stick, the front jaws engage cam rails which effectively open the jaws front and back and permit the stick of can ends to slide a very short distance until the first can end engages of the being discharged stick engages the last can end of the exiting string.

Assuming now that it is desired to place the load regulator apparatus 10 in operation, it will be assumed that all trays 72 are empty and that it is desired to begin operation. At this point, the presses furnishing the supply of can ends are started, and as ends move down their respectively associated plural conveyors and into the mover area where they are received in the individual incoming lanes. At start-up, perhaps only one shell press might be operated initially. Inasmuch as it is assumed that all

-40-

trays are empty and that there are no ends in storage, all incoming ends are advanced uphill to the inbound staging areas one stick per lane at a time. The transfer head transfers the sticks positioned in the transfer station staging areas 34 one stick at a time to any empty trough of a tray in the storage deposit and retrieval areas 38 and 40. Accordingly, the appropriate signal having indicated that no transfer is to be made to the outbound lanes, an empty tray is removed from the empty tray magazine by cycling the tray feed so as to remove a single tray 72 from the tray support in the empty tray magazine 22 and place it on the cross feed conveyor 76. The tray is thereon indexed to the station 38 within the transfer station 12. Thereafter, as each succeeding array of ends is subdivided, placed in the inbound staging area and picked up, it is transferred at the provided station 38 into any next open trough or channel 74 in the being-filled tray 72. Once filled, the tray is advanced to filled tray magazine and lifted to form a stack of filled trays as shown in the sequence of Figs. 15-23. Under this assumption, the cycling just described would continue until a desired number of trays, say four or five, would be filled with ends. Up to this point the apparatus has functioned as a tray loader apparatus.

Thereupon, it is assumed, the downline or downstream machine or workstation would be prepared for operation and the apparatus 10 would receive a command to fill the outbound staging lanes 36 and the consolidation areas 32 and so as to continuously feed can ends in a string along lanes 68 to the downline apparatus. In this sequence, it is assumed that the supply ends received from the shell press is continuing. Since there is now a demand in the

-41-

outbound staging area for a supply of ends, the previously subdivided sticks of ends are taken from the inbound staging area 34 and transferred directly to the outbound staging area 36, being fed respectively to each of the outbound track segments 66 in the outbound staging area as called for the downstream machines.

This cycling would continue, with all transfers of article groups or sticks being achieved continually. Assuming for the moment that the input or supply rate exactly equalled the demand rate, direct transfer by the pick-up head between staging areas 34 and 36 would continue. Assuming for the moment, however, that the demand in the downstream work stations exceeds the instantaneous supply, or by the presence of open areas in the tracks in the consolidation areas, e.g. by under supply sensor at the outfeed track 64 adjacent consolidator 32. In addition to the sticks of ends being transferred from the inbound staging area to the outbound staging area, the transfer apparatus 121 would periodically pick up sticks of ends from a channel 74 in a tray 72 in the transfer and deposit areas 38 and/or 40. These sticks would be deposited in the appropriate outbound lane 66 in the outbound staging area 36, to supplement the directly supplied ends. This transfer from storage to the outbound staging area would occur as indicated by the demand on the downstream side. In five or ten direct transfer cycles, or otherwise as often as is indicated.

Assuming that the supply of incoming ends were to cease altogether, then the entire outbound staging areas would be supplied with ends taken from storage, and the

-42-

machine would cycle repeatedly in this mode only. Thus, where there is a deficit in the supply, the demand is filled by direct transfer plus transfer supplementary ends from storage, with the possibility being that anywhere between  
5 some and all of the ends could be supplied from storage. If supply is completely halted, and all ends are placed from storage, the apparatus 10 is functioning as a tray unloader device.

Assuming for the moment, that the supply were in  
10 excess of the demand, ends would be placed in storage as indicated; in such instance, every fifth, tenth, twentieth stick could be placed in storage, for example. Of course, upon initial start up, or if the demand became zero as a result of line stoppage for maintenance, access, or the  
15 like, then all inbound ends would be placed in storage on a group-by-group basis, as previously indicated.

Accordingly, it will be seen that any amount, including the entire inbound amount of articles could be placed in storage; any outbound amount, including all the  
20 outbound articles, could be taken from storage, and any proportion of the outbound articles could be supplied from direct transfer to or from storage, depending upon conditions. The conditions are instantaneously reversible, with the machine operating on a group-by-group basis. In  
25 other words, if there were a temporary excess of inbound ends, they could be placed in storage and even removed from the same placement into storage on the same or next following cycle. Thus, the response time of the machine is substantially zero.

30 Referring again to Fig. 36, a schematic representation of the above-described form of machine

-43-

operation is shown. Here, operations which are optional or intermittently performed are shown in broken lines, while preferred or necessary operations are shown in solid blocks.

Thus, block 400 indicates that a supply of ends is  
5 being provided from an upstream machine such as a press, and shows that these ends may be accumulated as shown in block 402. A preferred but technically optional step is shown in block 404, namely, subdividing the strings of ends which have accumulated into groups for batch handling. Block 406  
10 shows inbound staging of ends, i.e., preparing the ends for transfer as indicated in block 408. The transfer may be a direct transfer to outbound staging as shown at line 410, whereby the ends accumulate transiently in the outbound staging area 412. From here the ends may be optionally  
15 advanced to a consolidator 414 from which they are fed to a downstream machine having a given demand as represented by block 416.

According to the invention, regulation or control is accomplished in one aspect by decreasing the  
20 instantaneous rate at which the net supply of ends is sent to the outbound staging area, and in another aspect by increasing the instantaneous supply rate to the outbound staging area. Line 418 shows that the net supply of ends reaching the outbound staging area is decreased by transient  
25 storage of certain of certain groups of ends. Here, a single container schematically designated 420 provides transient storage or retrieval by group. An increase in the net supply rate to outbound staging is accomplished as shown at 422, namely, by retrieving groups of ends from the  
30 transient storage area 420 and using these groups to supplement the groups of ends being furnished directly from

-44-

inbound to outbound staging areas from time to time. Block 423 and flow lines 424 and 426 show, respectively, storage or retrieval by container, i.e., adding ends to storage or retrieving ends from storage in full trays, i.e., upstacking or downstacking full trays. Step 426 shows upstacking or downstacking empty trays to add to or withdraw from the reverse tray or storage container capacity of the apparatus.

Control unit 428 is shown as detecting excess supply, block 430, thereby enabling or activating the condition shown at line 418, to decrease the net supply of article to output; where the demand is in excess of the supply as shown at 432, the condition in line 422 is enabled or activated, and the supply is supplemented.

The most essential steps are, therefore, inbound and outbound staging, transfer and storage, and retrieval by group under the control of the condition detector. Storage by container adds flexibility, while the accumulation and subdivision of ends, as well as consolidating ends may be considered optional in the sense that the machine need not itself include these elements to incorporate the invention.

Referring now to certain individual features, the machine logic is of a kind known to those skilled in the art, with various disabling and enabling controls being provided as indicated. Thus, in order for a pick up to be made from an inbound staging area, the lane must be entirely filled as indicated by an appropriate trailing edge sensor which would require a positive-going signal from a leading edge sensor, for example. The transfer to and taking from storage involves a complete stick and inasmuch as the ends or other articles are loaded into the tray in individual sticks, there is no need for gauging the stick lengths

-45-

during each cycle.

Referring now to movement of the head portion of the transfer apparatus, the cycle time of this apparatus must be at least as many times faster than the fill-up time of individual infeed areas as there are separate infeed lanes. Thus, if there are four infeed lanes, each requiring twenty seconds to be filled, the machine should be able to engage, remove, and deposit a stick in less than five seconds, so that the maximum input capacity of the apparatus could be accommodated. By the same token, the number of transfer cycles able to be achieved by the head is the limiting factor of supply rate to the outbound lanes. The proximity or position sensors referred to may be of the photoelectric, magnetic, or other known type including those operating on infrared or visible light, utilizing the "Hall" effect, or otherwise as known to those skilled in the art.

A detailed description of the invention has been given, with regard to an embodiment wherein a single transfer head is used; it will be understood that two or more such transfer heads may be used if desired. The articles being manufactured are identified as can ends, but it will be appreciated that any kind of arrayable, mass produced articles which are subject to transfer between work stations, including assembly stations, are adapted for handling by the apparatus of the invention. These include metal and plastic parts of all kinds. The principles of the invention are applicable to balancing or regulating any type of work loads.

The invention is not limited to chain type conveyors, since hydraulic or other positioners may be used.

-46-

A tray magazine with a vertical feed has been shown, but inverting or folding type stackers may be used, and containers other than trays may be used. Similarly, the storage capacity might be accommodated on, or form an integral part of, a conveyor or a single reciprocable container. Other mechanical variations of the apparatus will suggest themselves to those skilled in the art of industrial process machinery. Sensing and leveling mechanisms and detectors may be of any known kind, and the program sequence may be as indicated by the designer.

The apparatus may also be integrated with apparatus intended to add additional components to the line, if desired. In other words, more than one style of article may be handled in the machine, and articles may be pre-arrayed or assembled into groups or subgroups before being handled as a subdivided group by the apparatus. The unit may be constructed so as to include the infeed and outfeed conveyors or merely so as to be able to be interfaced with them. The method of the invention may be carried out by other types of apparatus as well.

Each of the above-mentioned commonly assigned patents and patent applications are specifically incorporated herein by reference.

Although the present invention has been described with reference to a preferred embodiment, modifications or changes may be made therein by those skilled in this art without departing from the scope and spirit of the present invention as defined by the appended Claims.



-47-

## We Claim:

1                   1. An apparatus for regulating the flow rate of  
2 an apparatus for articles moving between an upstream work  
3 station serving as a source of supply for such articles, and  
4 a downstream station having a demand for such articles, said  
5 apparatus having means for transiently accumulating inbound  
6 articles being fed in a continuous array, means for  
7 subdividing said continuous array of articles into  
8 individual groups, means for accumulating groups of articles  
9 intended to be fed downstream and means for advancing and  
10 consolidating said groups into at least one continuous array  
11 of articles destined for said downstream work station,  
12 article group transfer means adapted to engage and transport  
13 said individual inbound groups of articles from said area in  
14 which inbound groups are being accumulated to said area in  
15 which said articles are to be accumulated for advancement  
16 downstream, means for transferring selected groups of  
17 articles from said inbound accumulating area to a storage  
18 area in a storage container means and for removing groups of  
19 articles from a storage area in said storage container  
20 means and transferring them to said area in which said  
21 downstream bound articles are accumulating, at least one  
22 storage container means and means for positioning said  
23 storage container means within the operating range of said  
24 transfer means, said storage container means including a  
25 plurality of elongate article group receptacle areas, and  
26 control means adapted to move said article group transfer  
27 means so as to supplement the number of groups of articles  
28 being fed to said downstream work station by adding groups  
29 of articles taken from said storage container means to said  
30 groups being transferred from said area in which said  
31 inbound articles are accumulating, and for diminishing the  
32 supply of articles fed to said area in which said downstream

-48-

33 bound articles are accumulating by transferring groups of  
34 articles from said area at which said inbound articles are  
35 accumulating to said storage area within said storage  
36 container means, said individual groups each having a  
37 generally linear configuration and each of said inbound  
38 accumulator means, said outbound accumulator means, said  
39 article and transfer means and said article group receptacle  
40 areas having a length dimension, extending generally  
41 parallel to each other and generally perpendicularly with  
42 respect to a longitudinal axis of said apparatus defining a  
43 transfer axis and a path of travel for said article group  
44 transfer means.

1       2. An apparatus as defined in Claim 1, wherein said  
2 means for transiently accumulating inbound articles includes  
3 a plurality of elongate, parallel spaced-apart guide  
4 channels configured to closely, slidably receive a  
5 continuous incoming stream of articles, each guide channel  
6 being disposed at an angled orientation with respect to a  
7 support floor upon which the apparatus rests, each guide  
8 channel including an article receiving end and an opposed  
9 article staging end positioned adjacent an article group  
10 transfer station, each said article staging end including a  
11 fixed stop means and a movable stop means mounted to said  
12 guide channel at a point spaced from the fixed stop means  
13 and intermediate the fixed stop means and the article  
14 receiving end, each said movable stop means including finger  
15 means movable between a stop position wherein the finger  
16 extends into the guide channel and a retracted position  
17 wherein the finger is withdrawn from the guide channel to  
18 provide enhanced article group management preparatory to  
19 transfer.

-49-

1           3. an apparatus as defined in Claim 2, wherein  
2 said article staging end includes a rotatable track segment  
3 movable between an angled orientation and a horizontal  
4 orientation coplanar with the horizontal plane including the  
5 transfer axis of the article group transfer station, means  
6 for rotating each said rotatable track segment between said  
7 angled orientation and said horizontal orientation and means  
8 for sensing when a group of articles has been moved along  
9 the guide channel into said article staging end and is  
10 gripped between said fixed stop and said movable stop  
11 preparatory to being rotated by the rotating means into a  
12 horizontal transfer position in the transfer station.

1           4. an apparatus as defined in Claim 1, wherein  
2 said outbound accumulator means includes a plurality of  
3 elongate parallel, spaced apart exit guide channels  
4 configured to closely slidably receive successive groups of  
5 articles, each exit guide channel being disposed at a  
6 downwardly angled orientation with respect to the plane of  
7 the transfer axis, each exit guide channel including a upper  
8 outbound article staging end and an opposed lower outbound  
9 consolidating and advancing end, means for grippingly  
10 receiving a transferred group in said outbound article  
11 staging end and for moving said group along said exit guide  
12 channel while maintaining it as a group from said outbound  
13 staging end to said consolidating and advancing end.

1           5. An apparatus as defined in Claim 4, wherein  
2 said outbound article staging end of said exit guide channel  
3 includes a rotatable track segment movable between a raised  
4 horizontal position aligned with the transfer station and a  
5 lowered angled position aligned with said outbound  
6 consolidating and advancing end and means for rotating said  
7 segment between said raised and lowered positions.

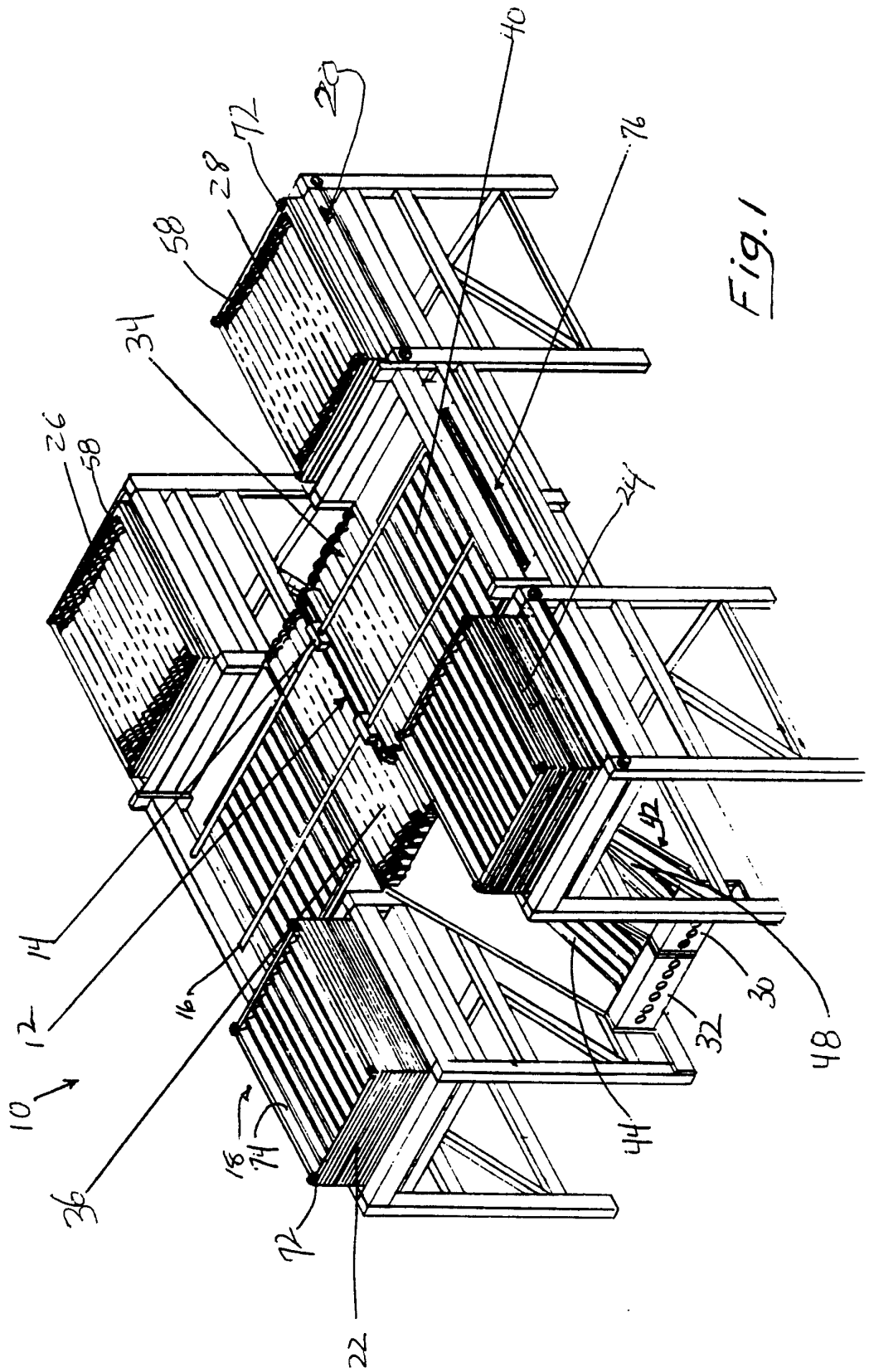

Fig. 1

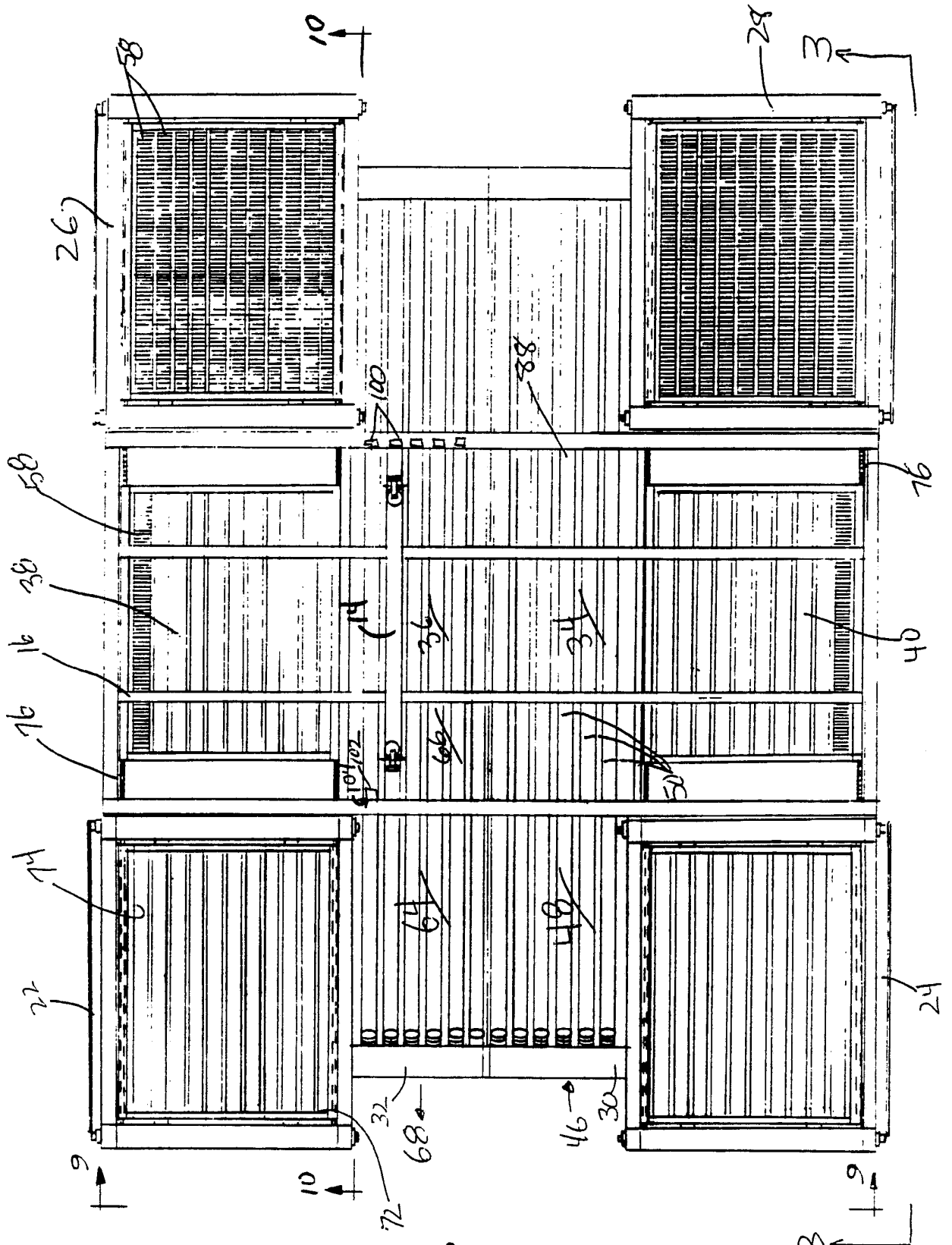

Fig. 2

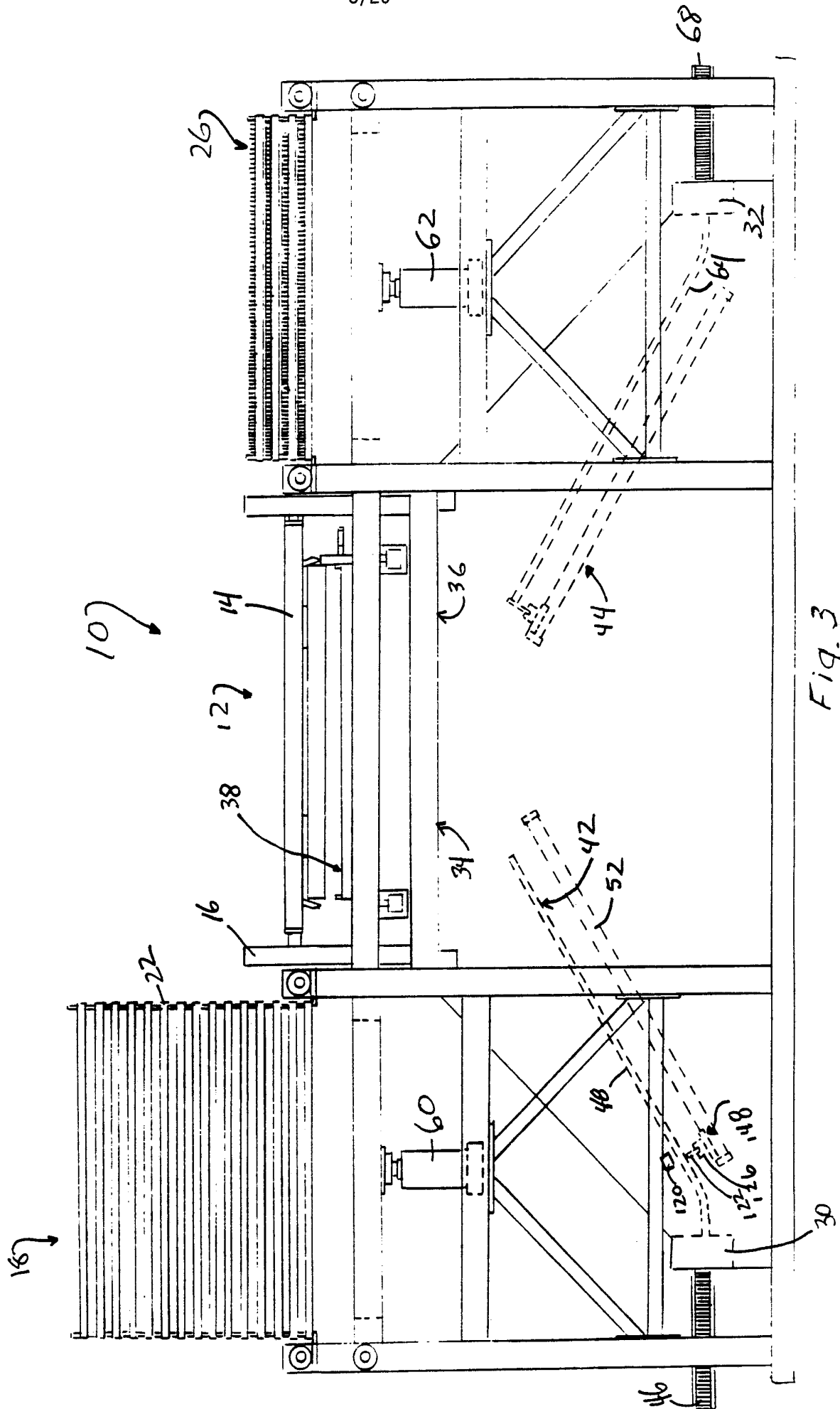

Fig. 3

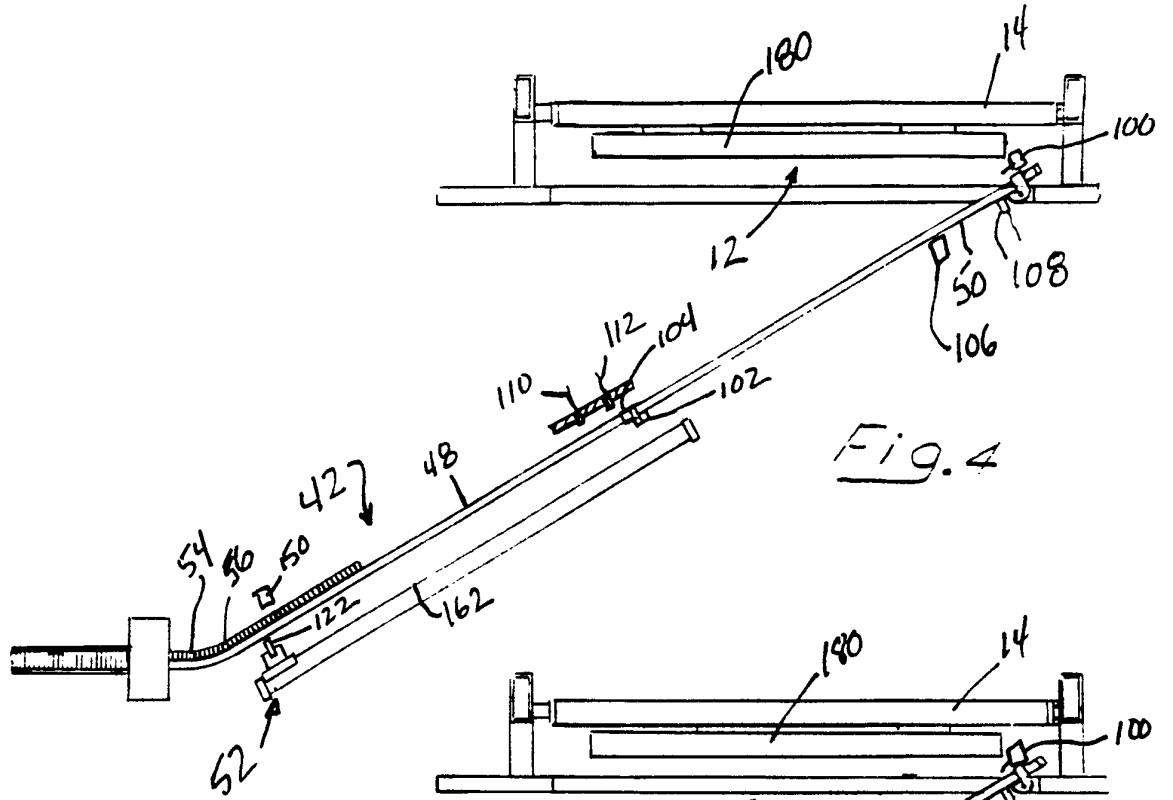

Fig. 4

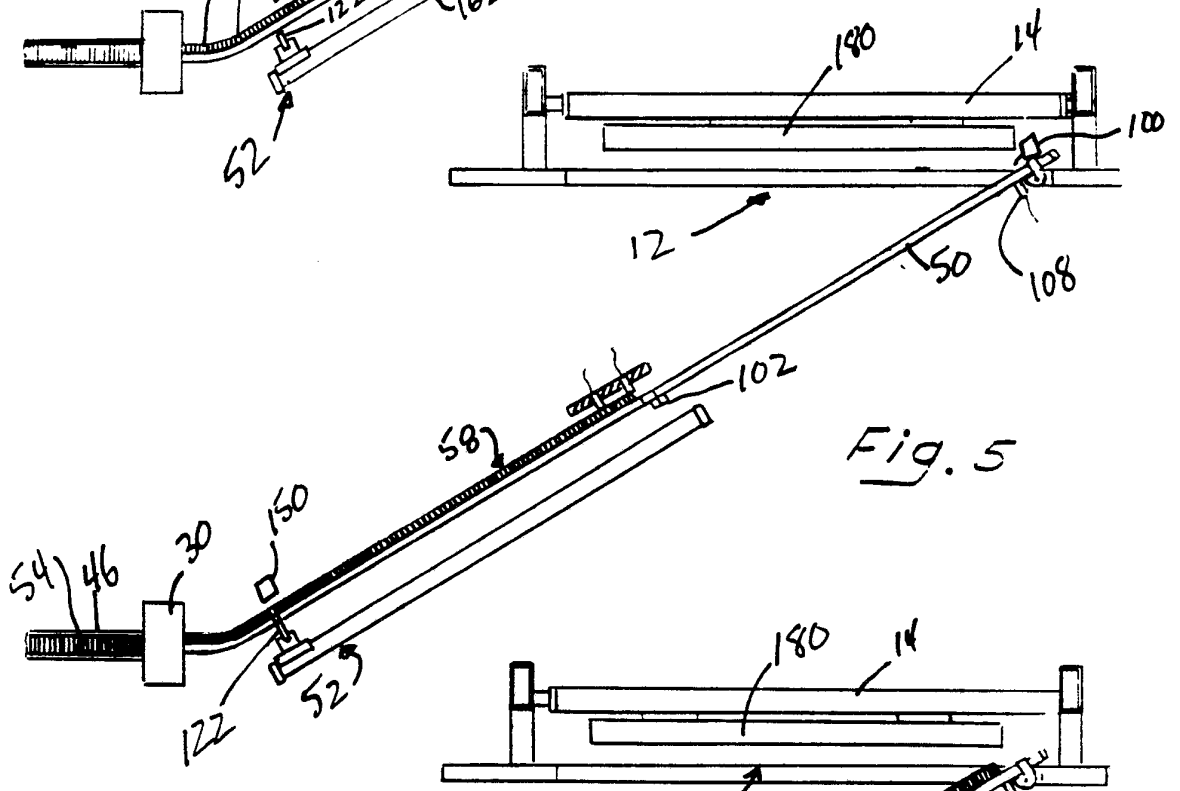

Fig. 5

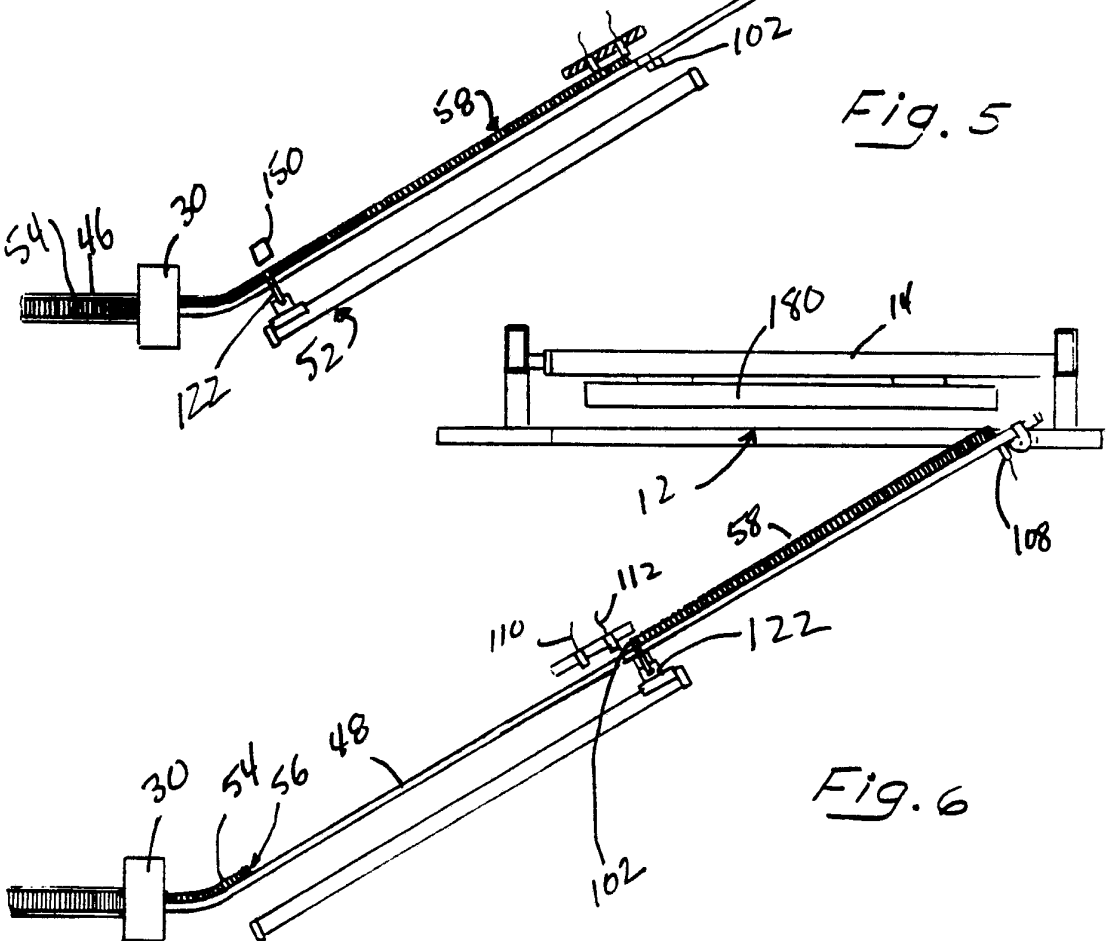

Fig. 6

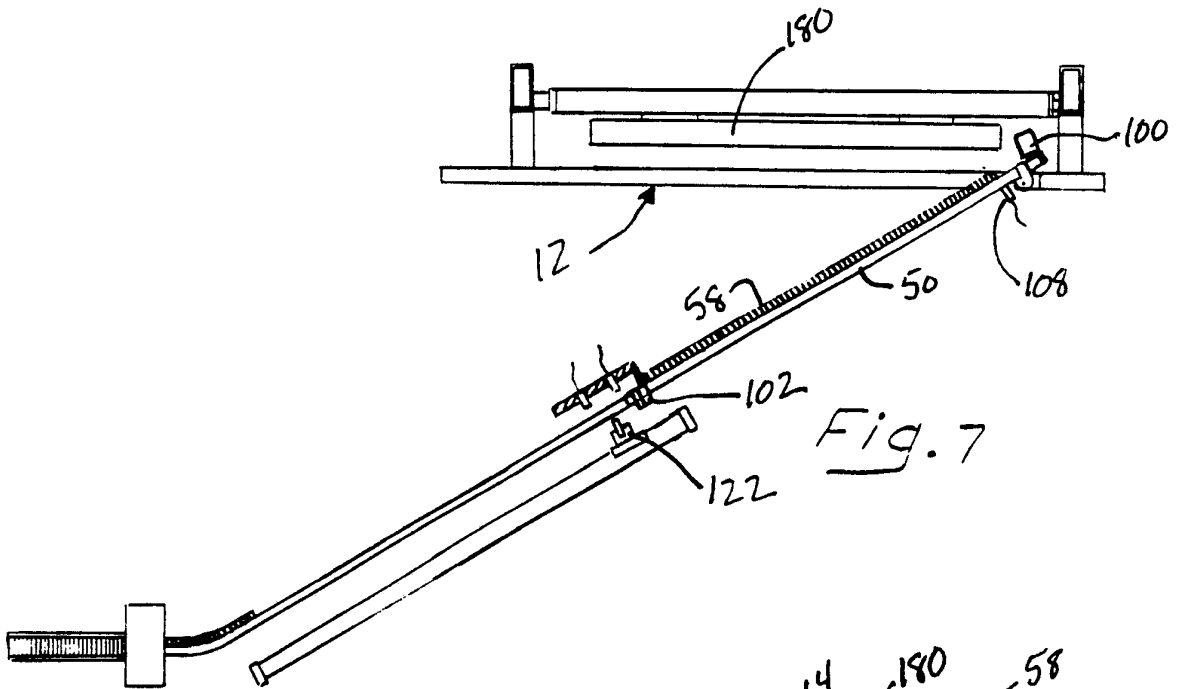

Fig. 7

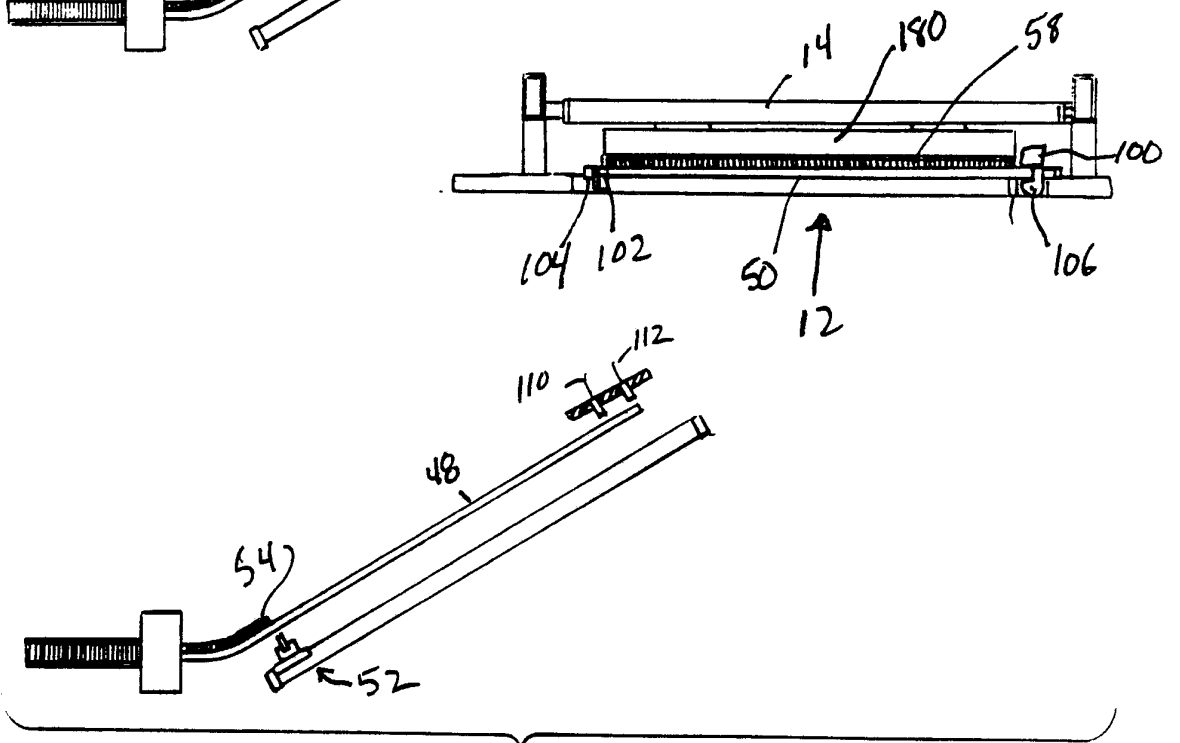

Fig. 8



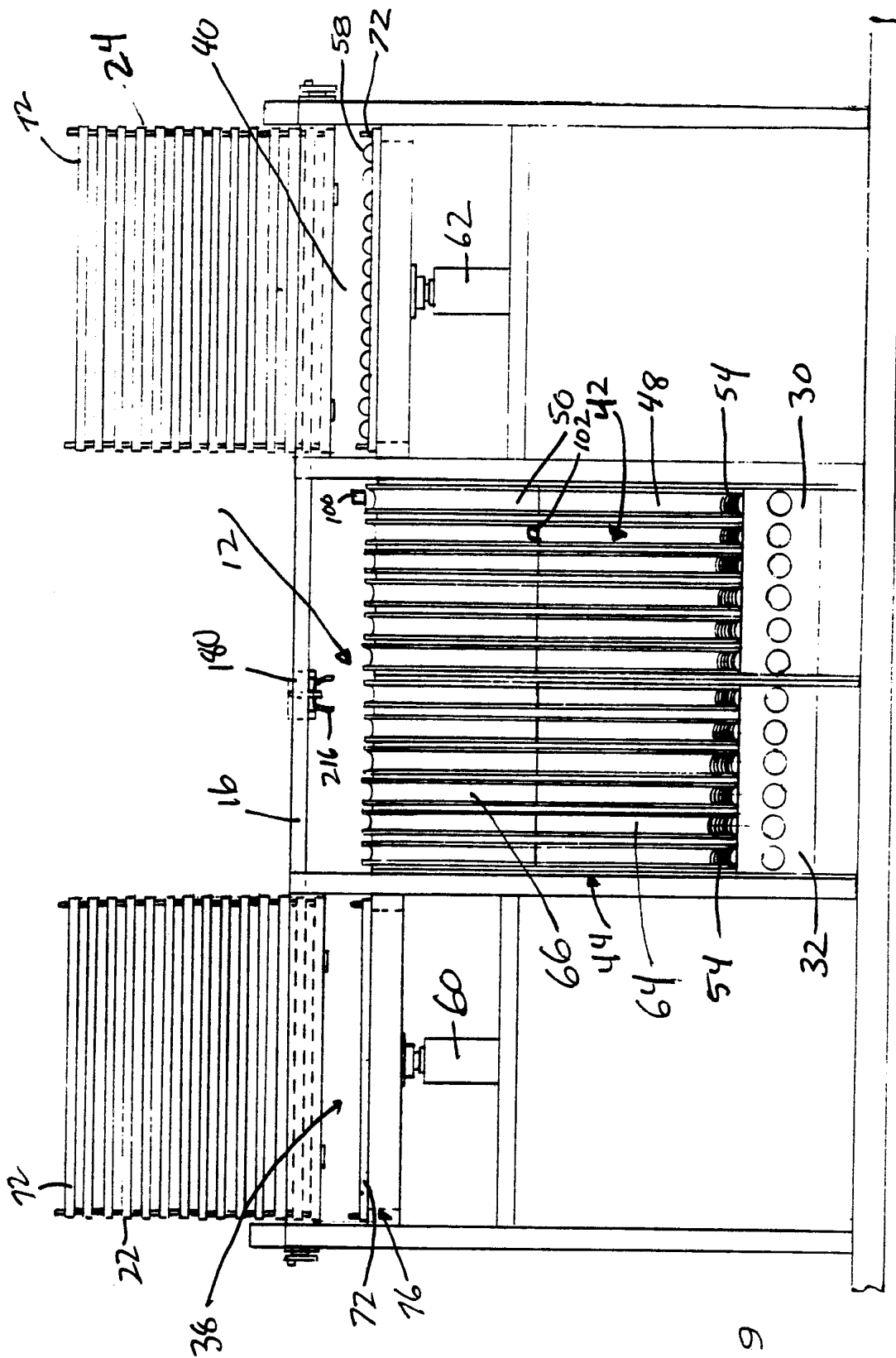

Fig. 9

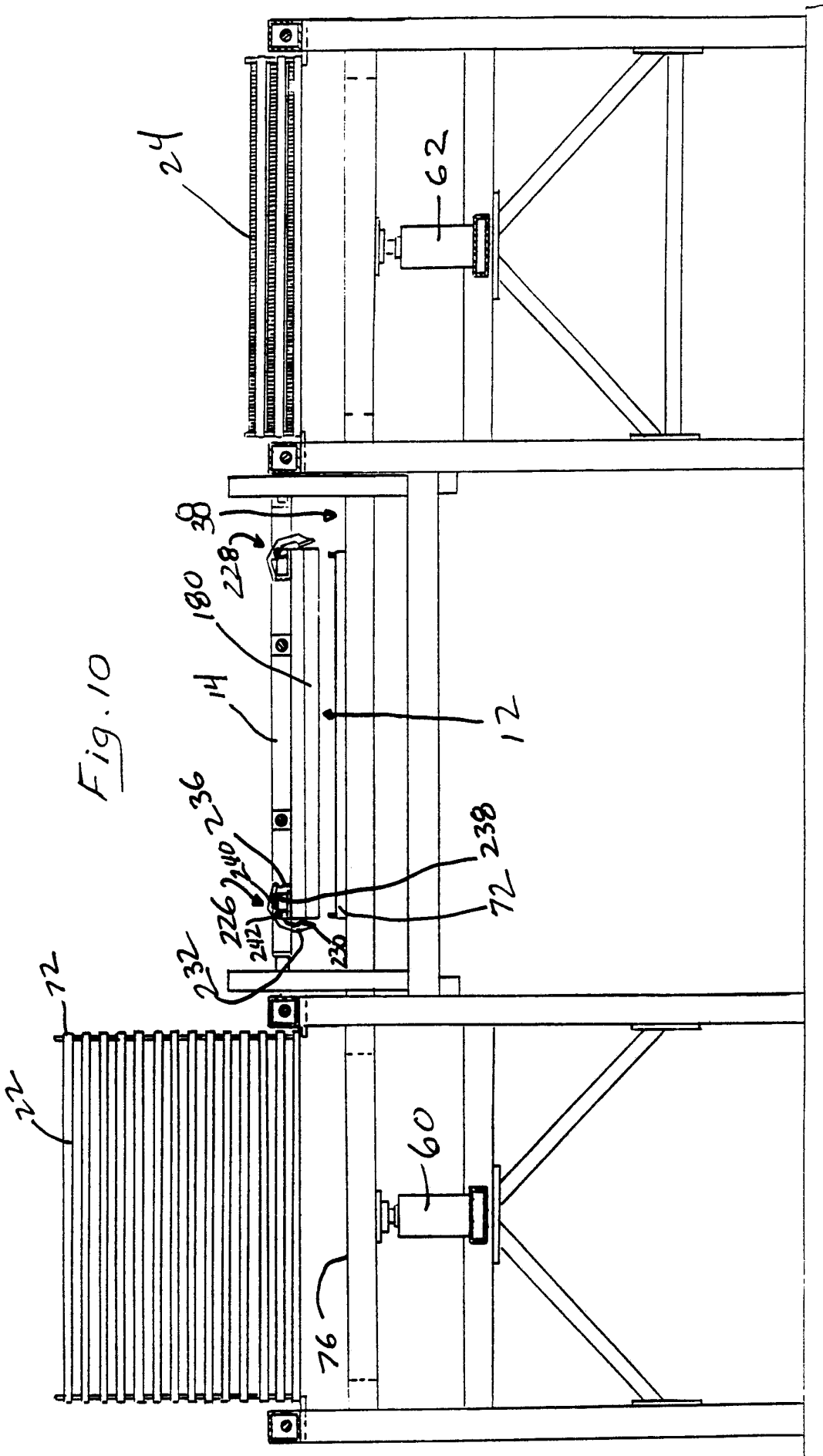

Fig. 10

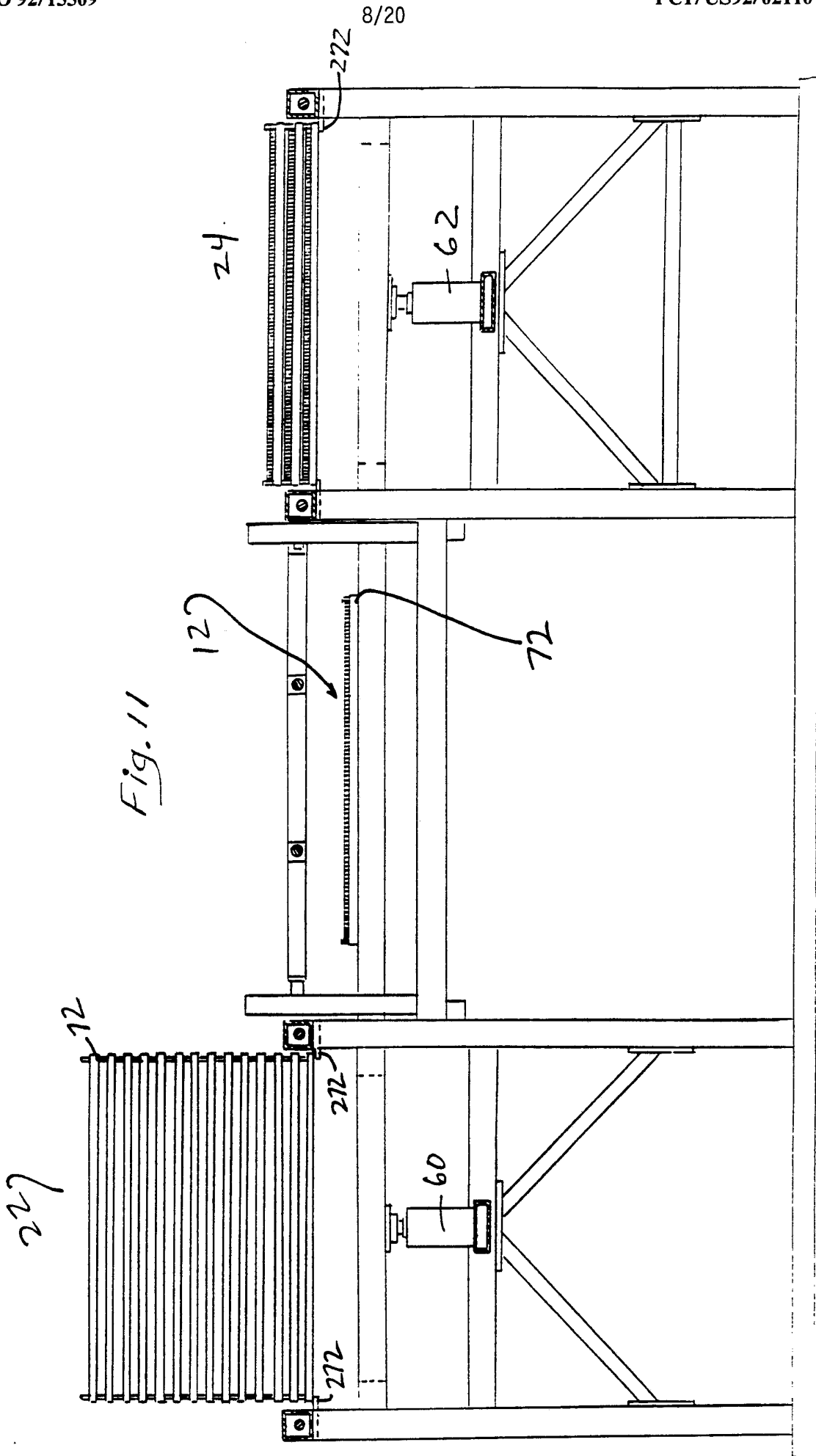

Fig. 11

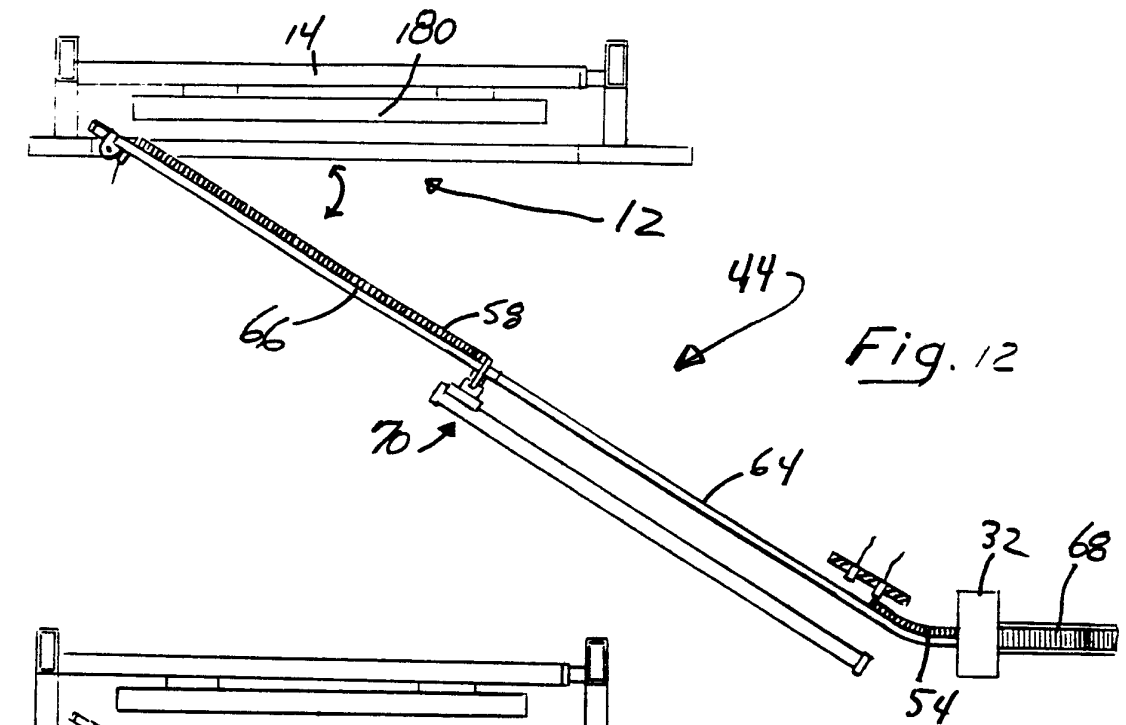

Fig. 12

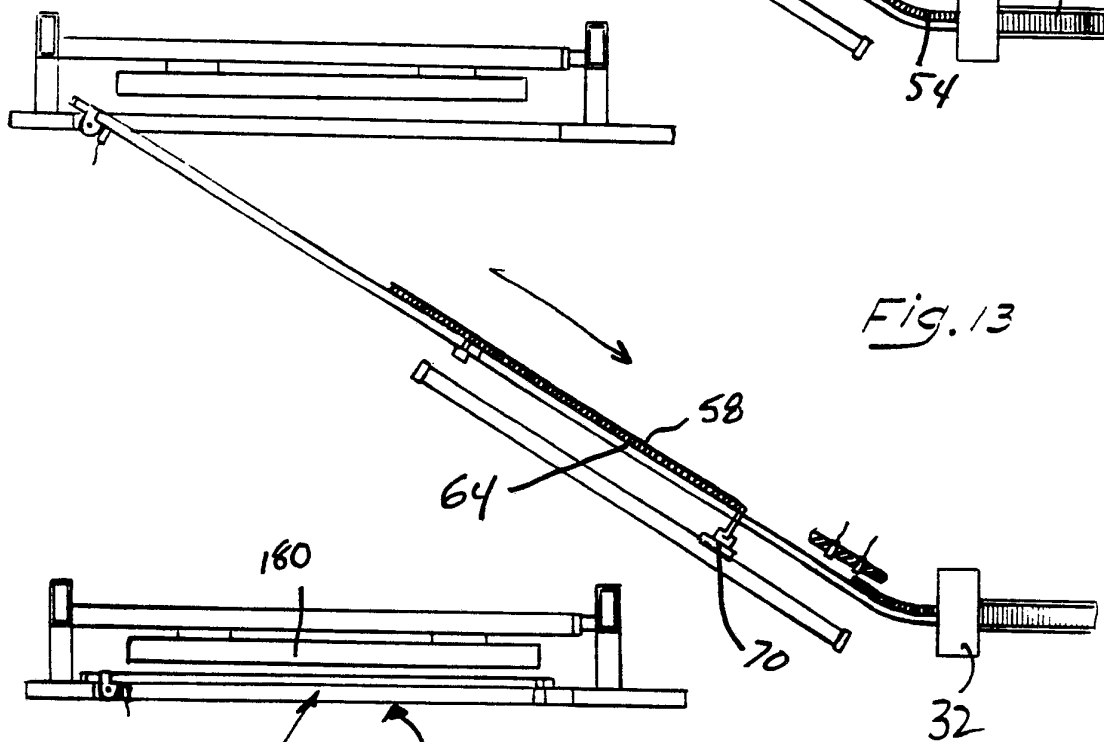

Fig. 13

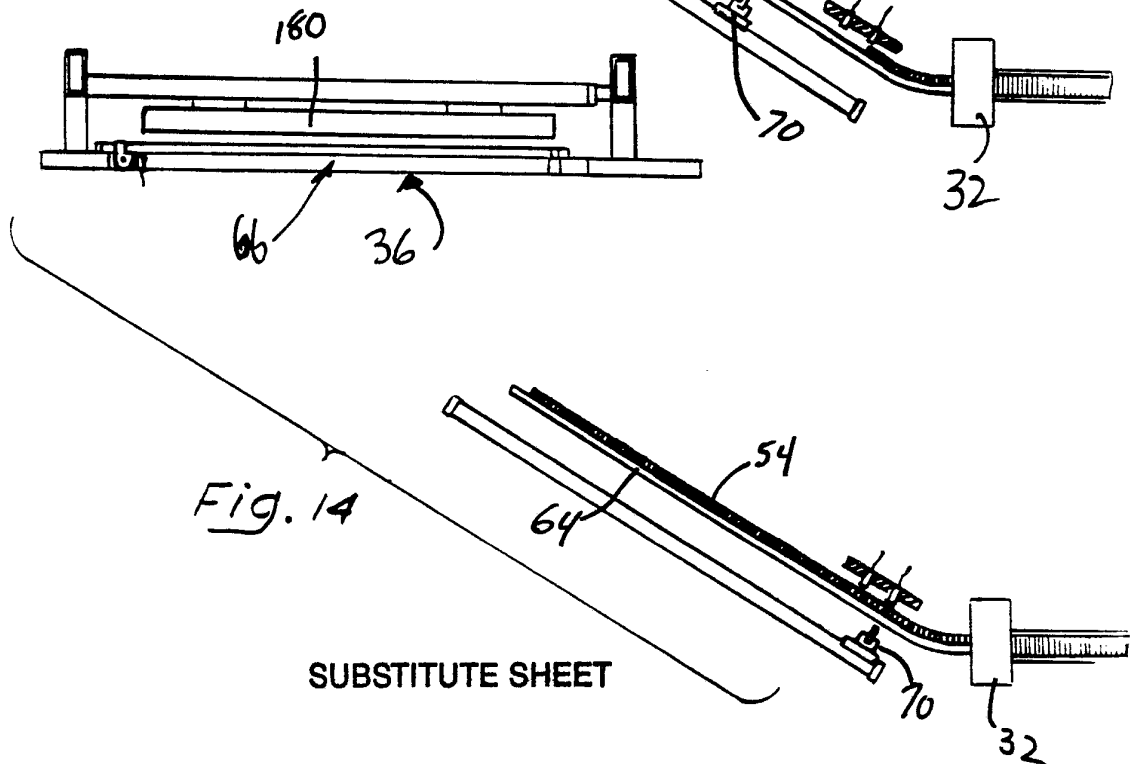

Fig. 14

SUBSTITUTE SHEET

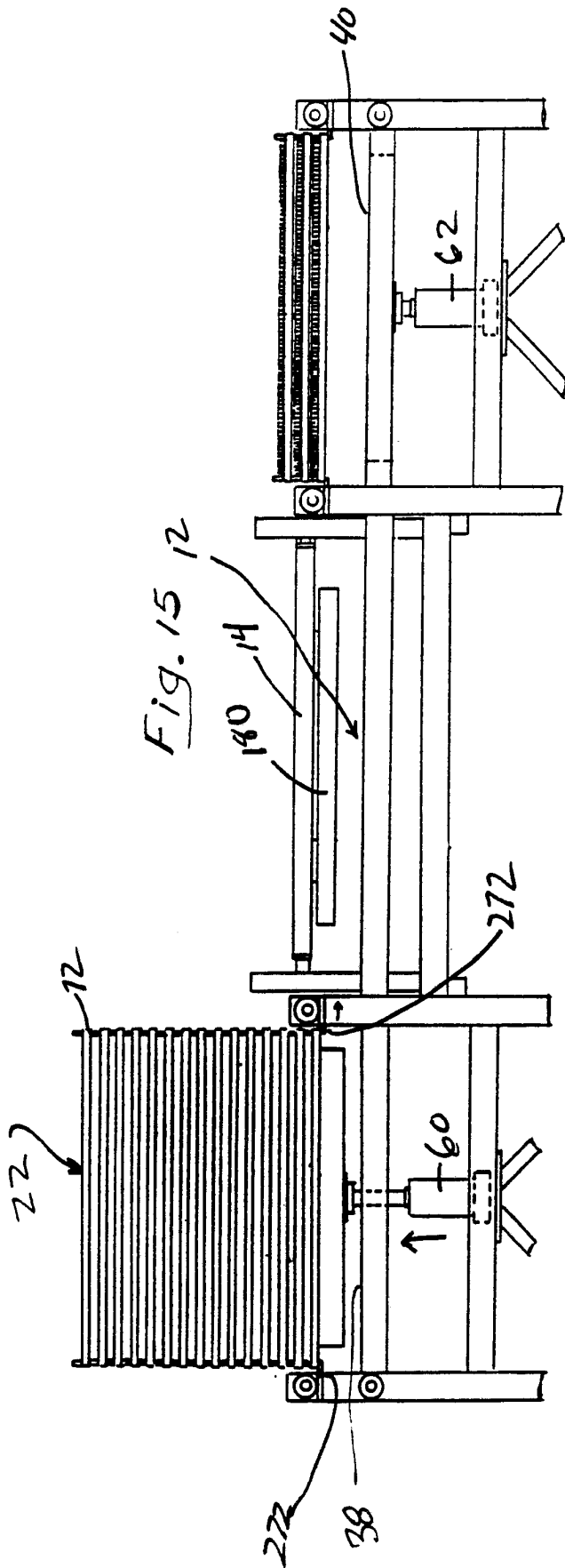

Fig. 15

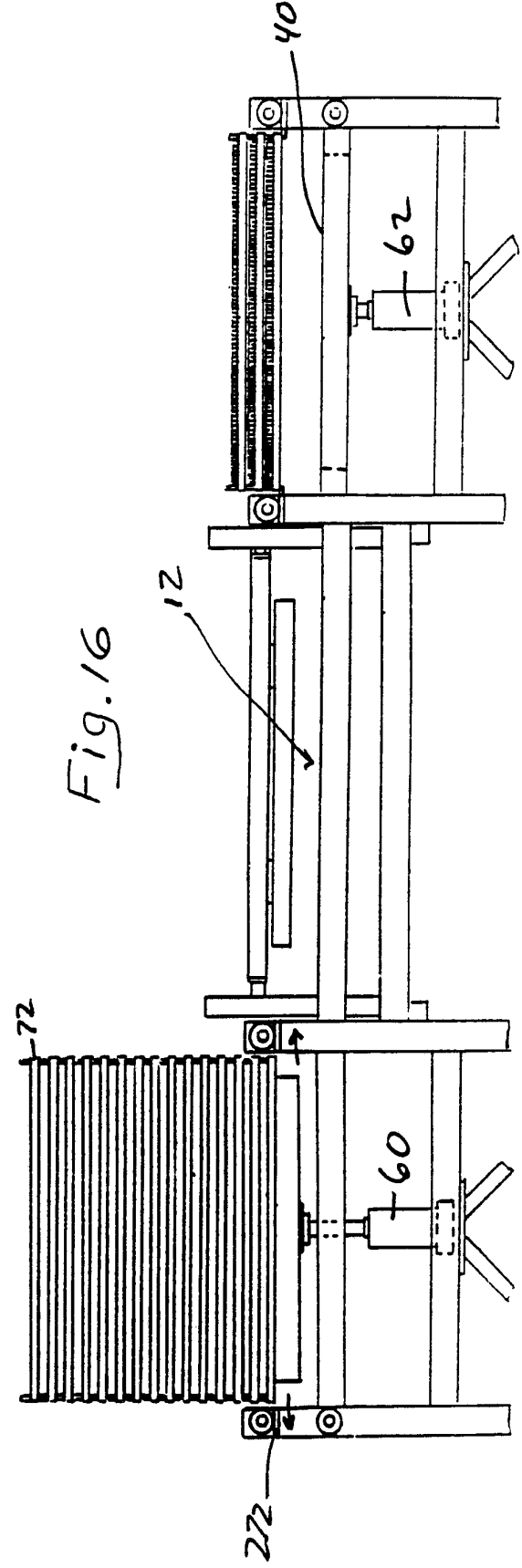
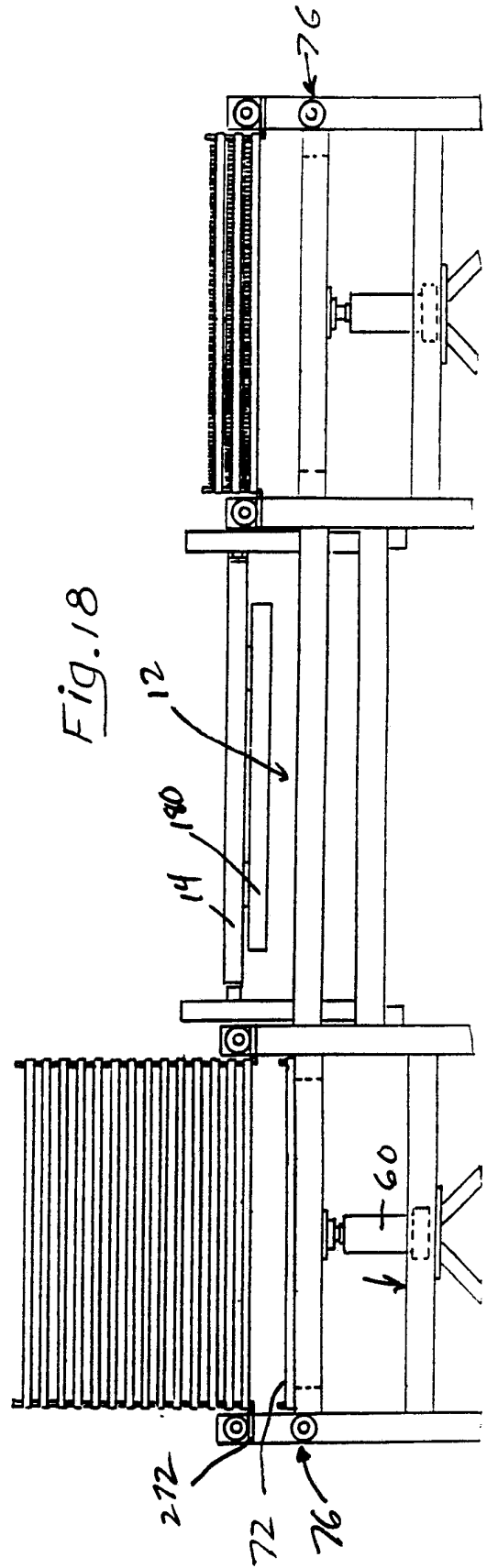
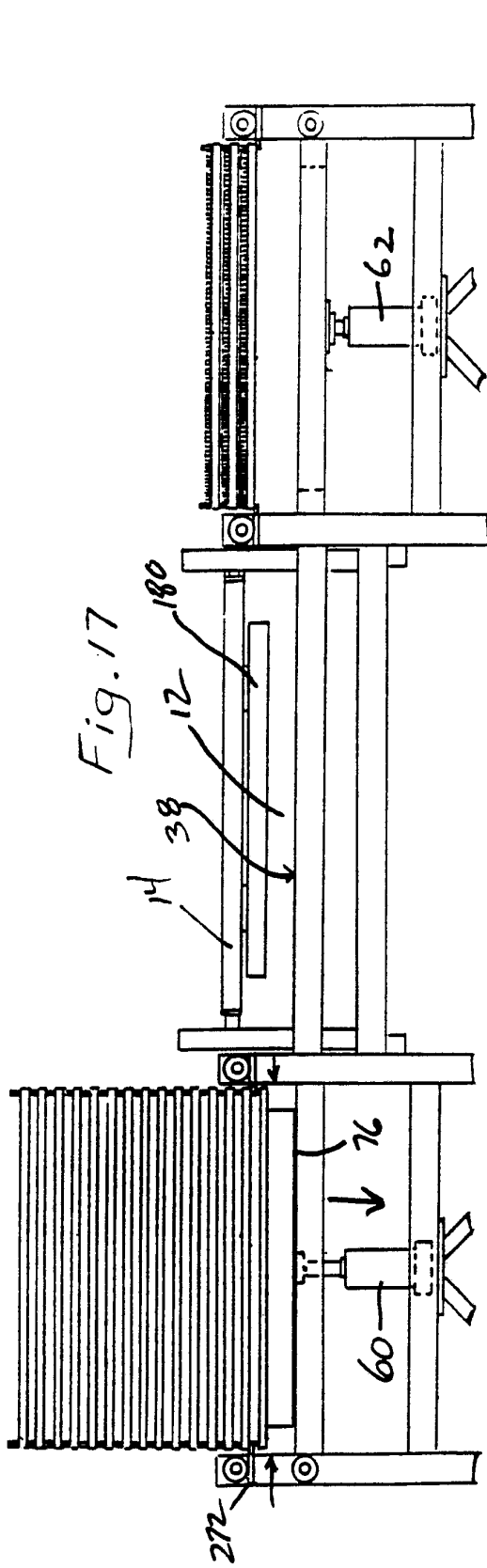
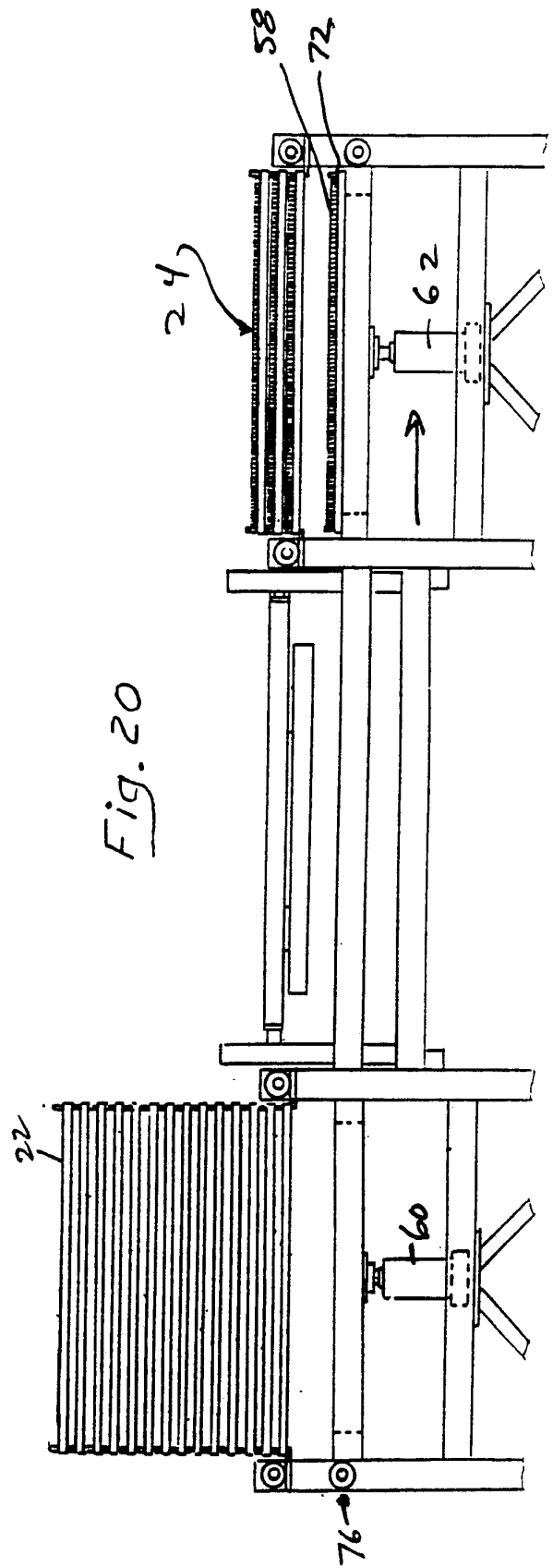
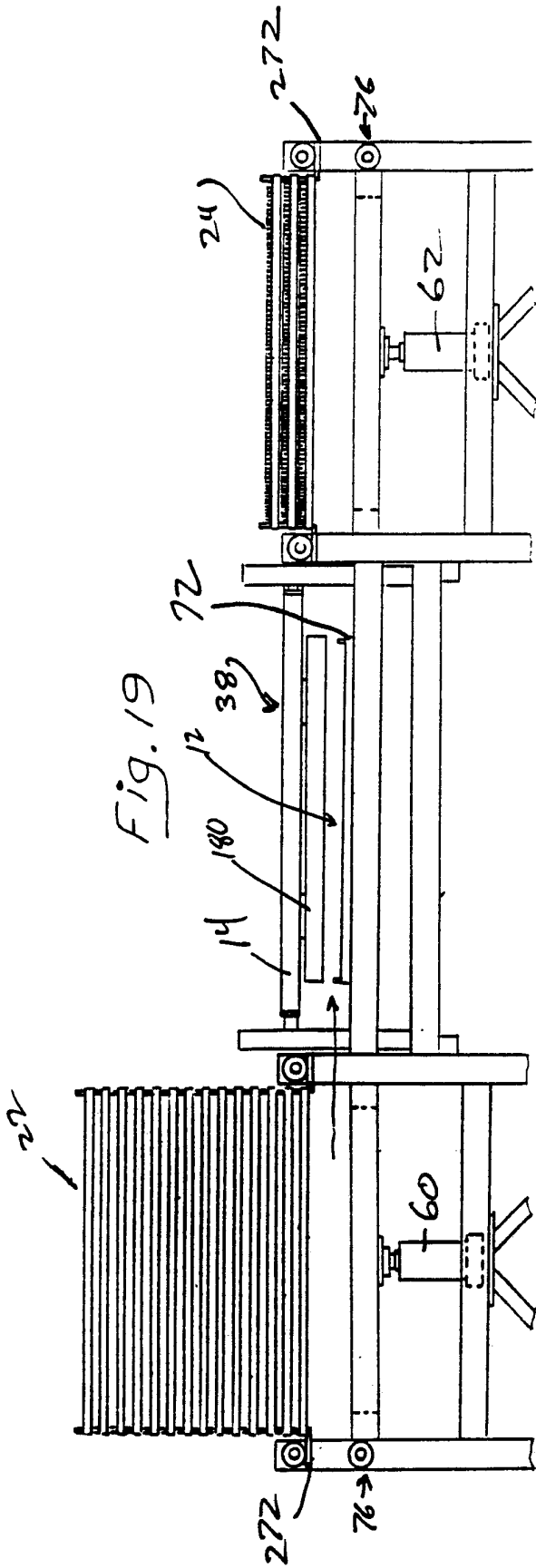
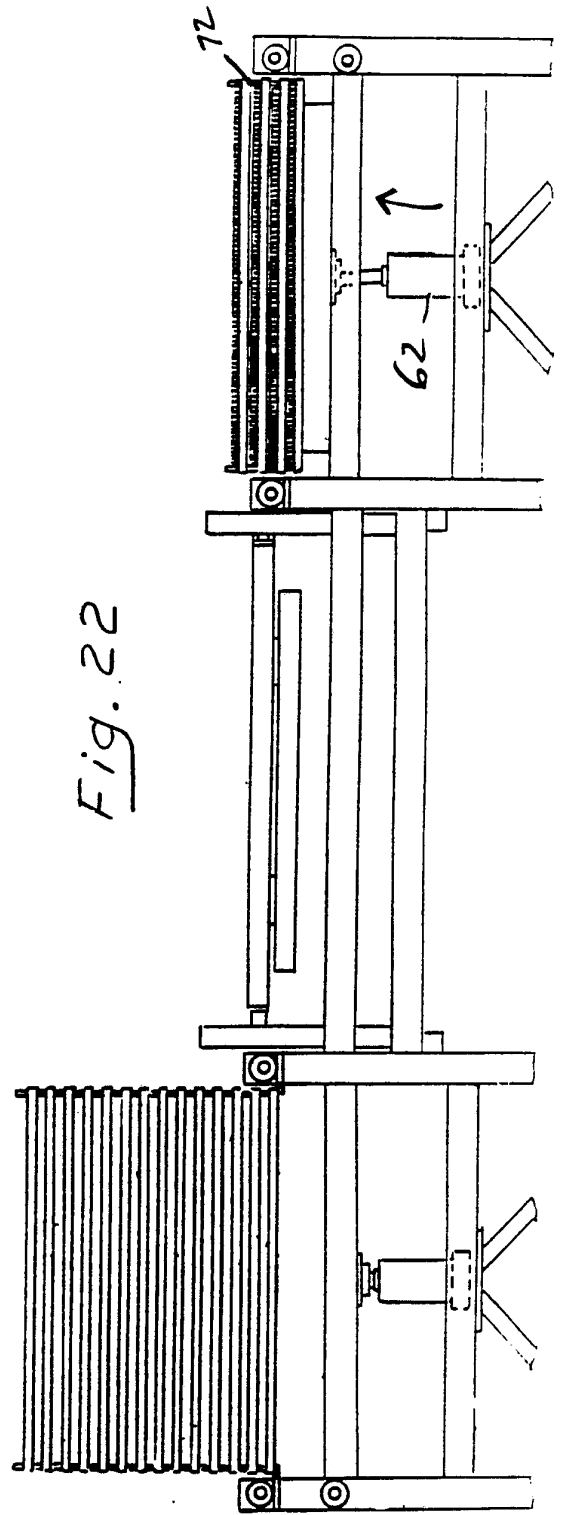
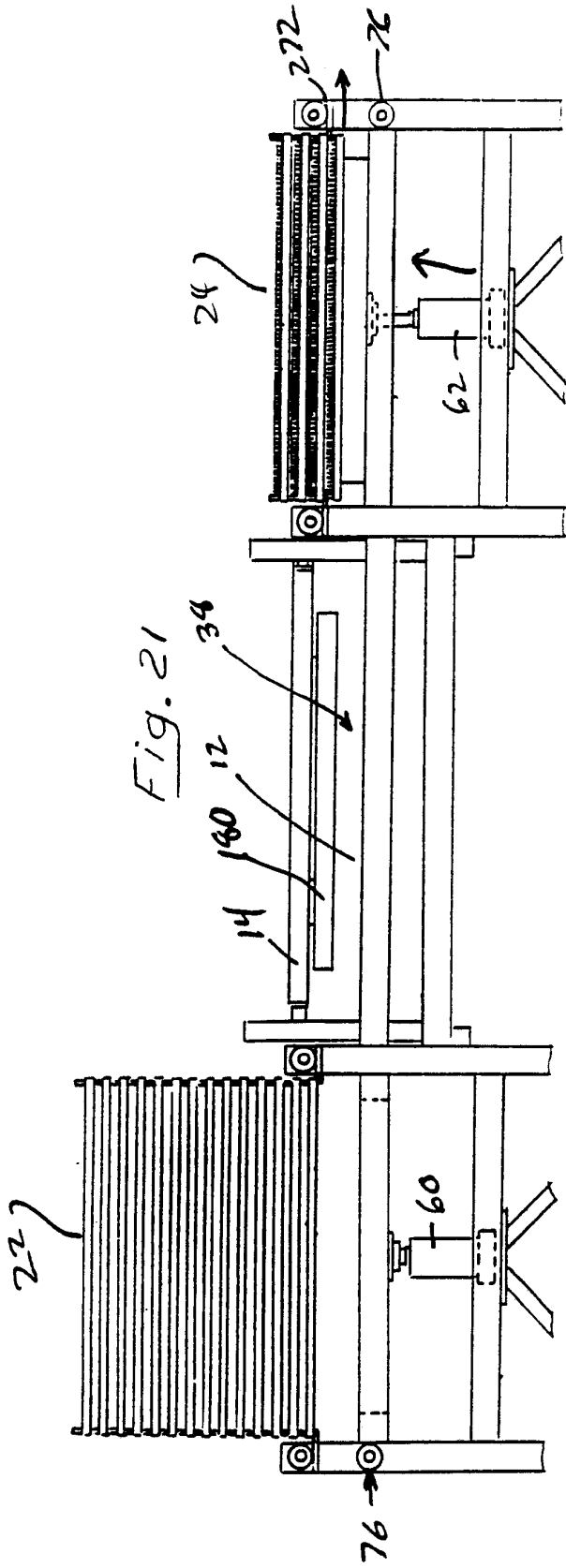

Fig. 16









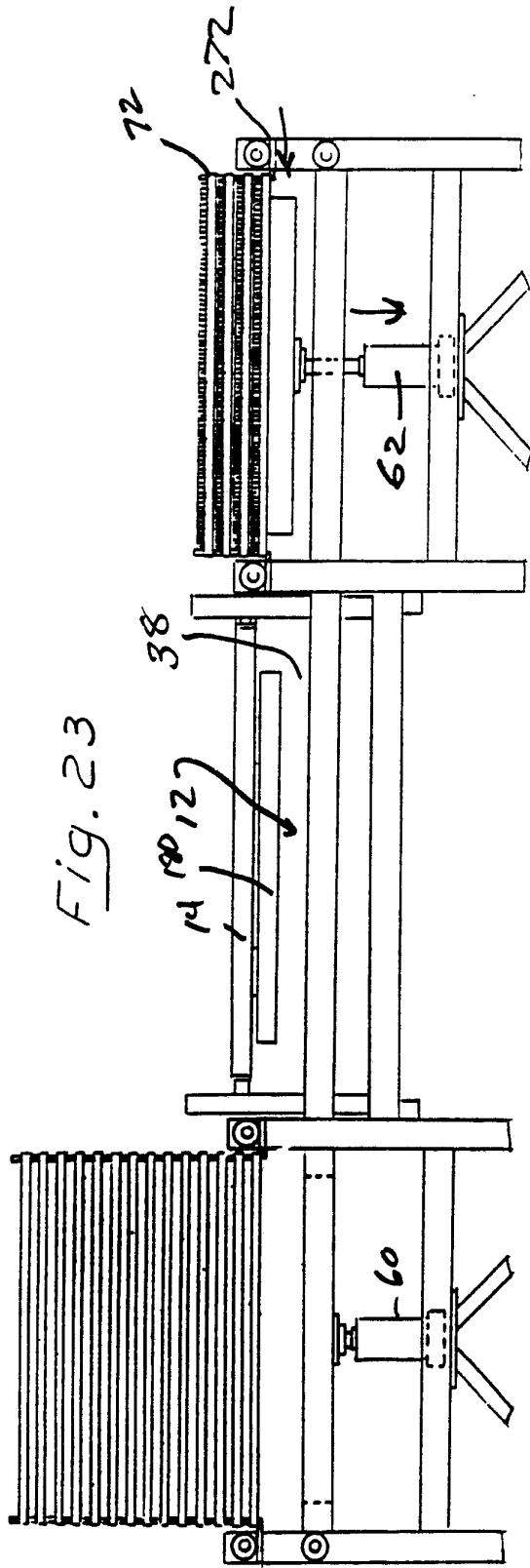

Fig. 23

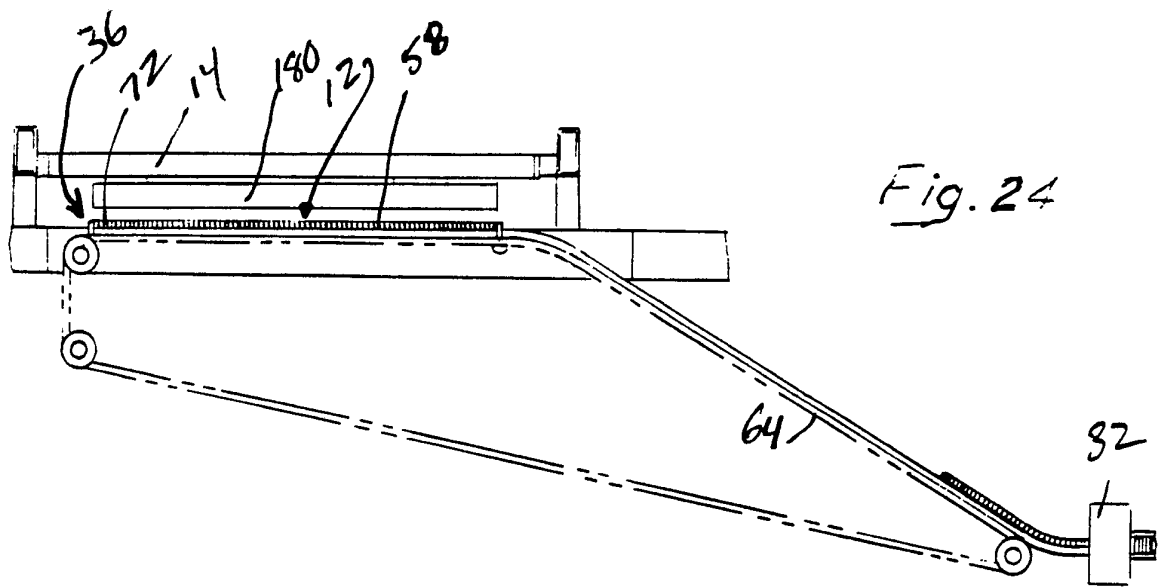

Fig. 24

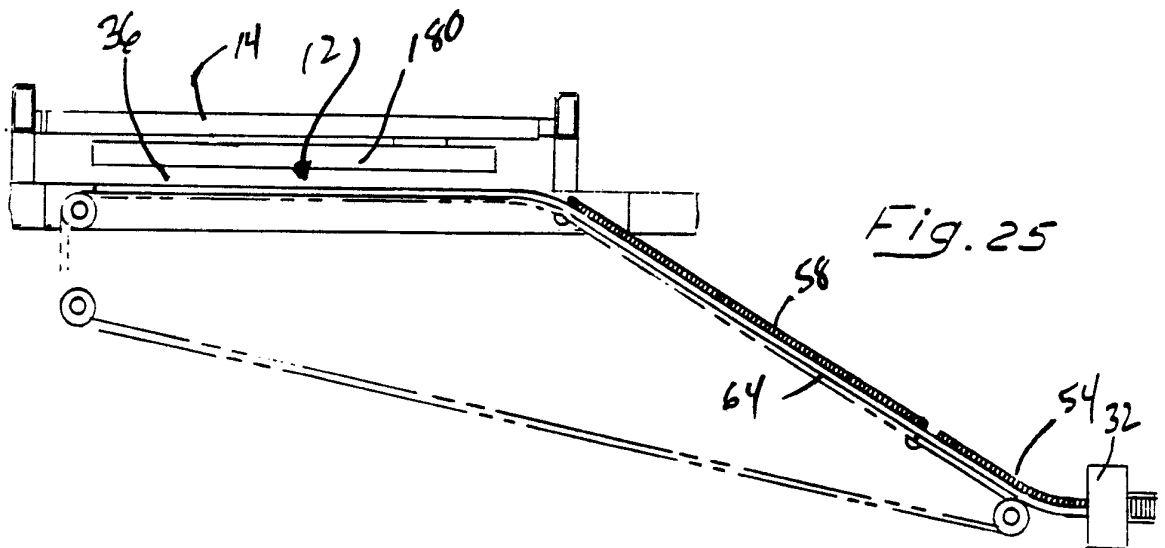

Fig. 25

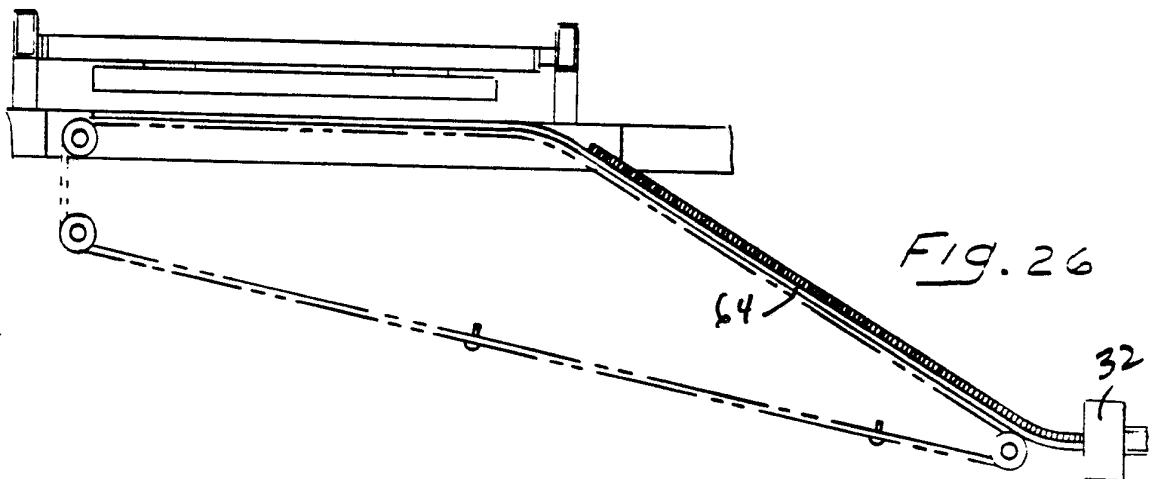
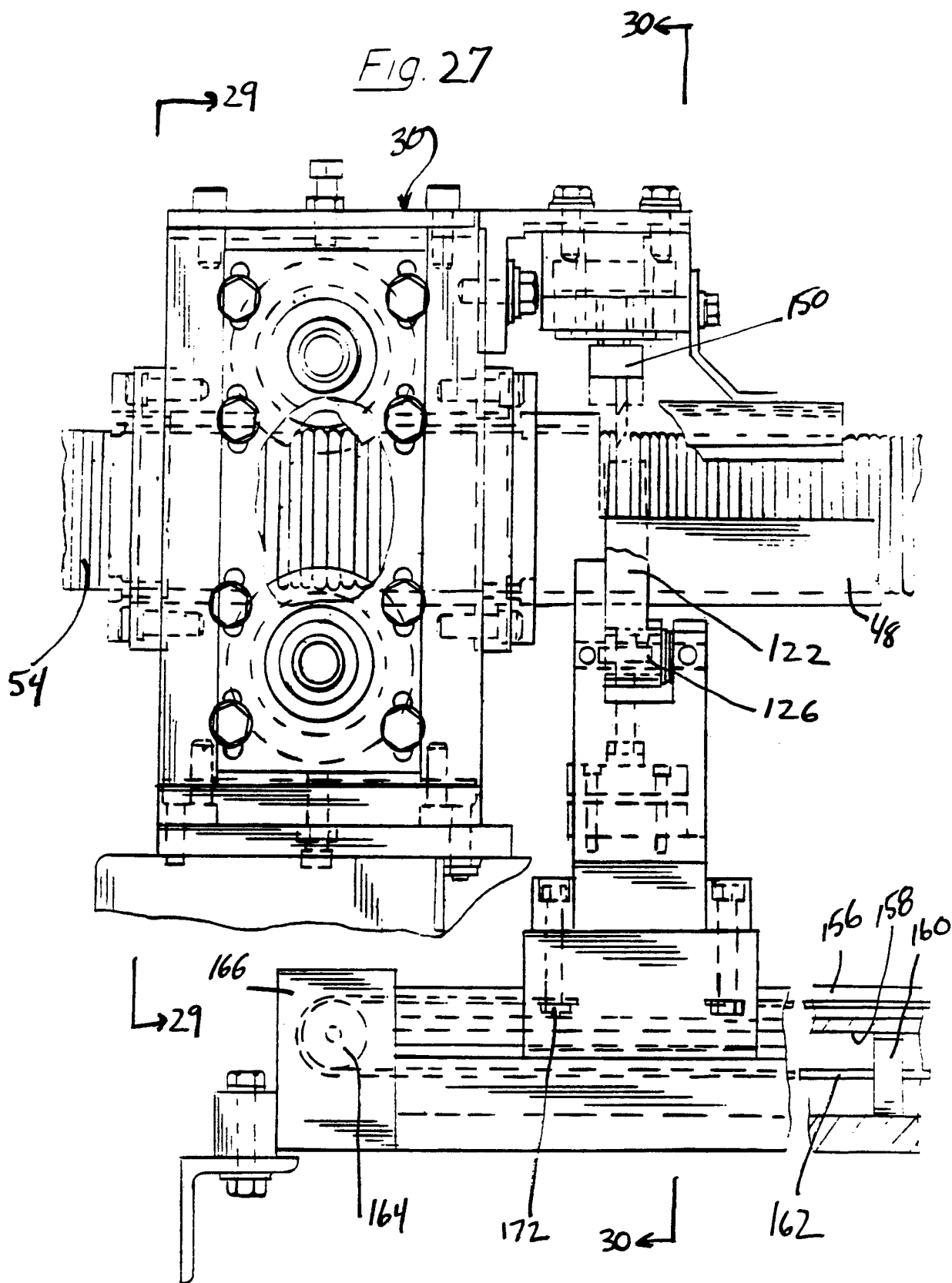

Fig. 26



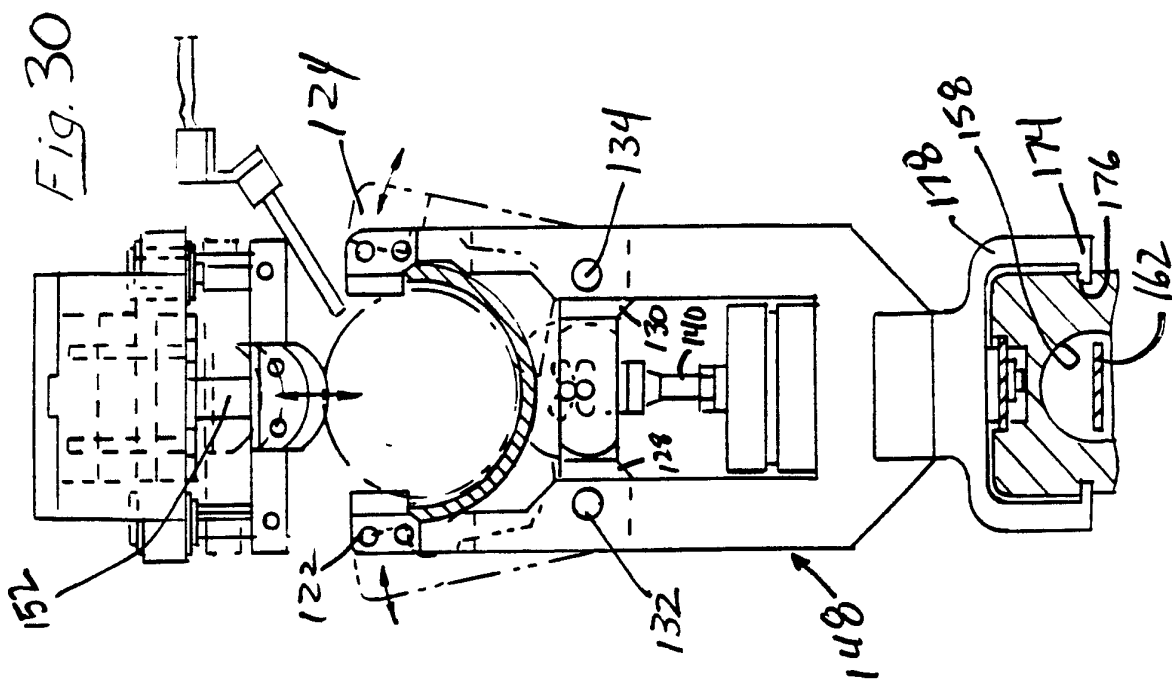

Fig. 28

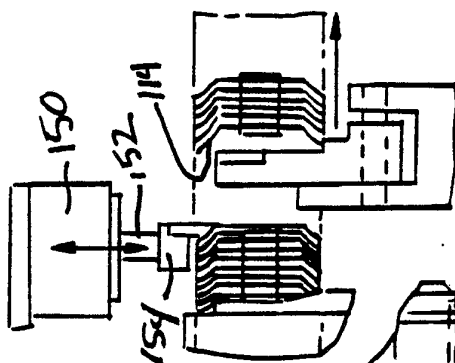
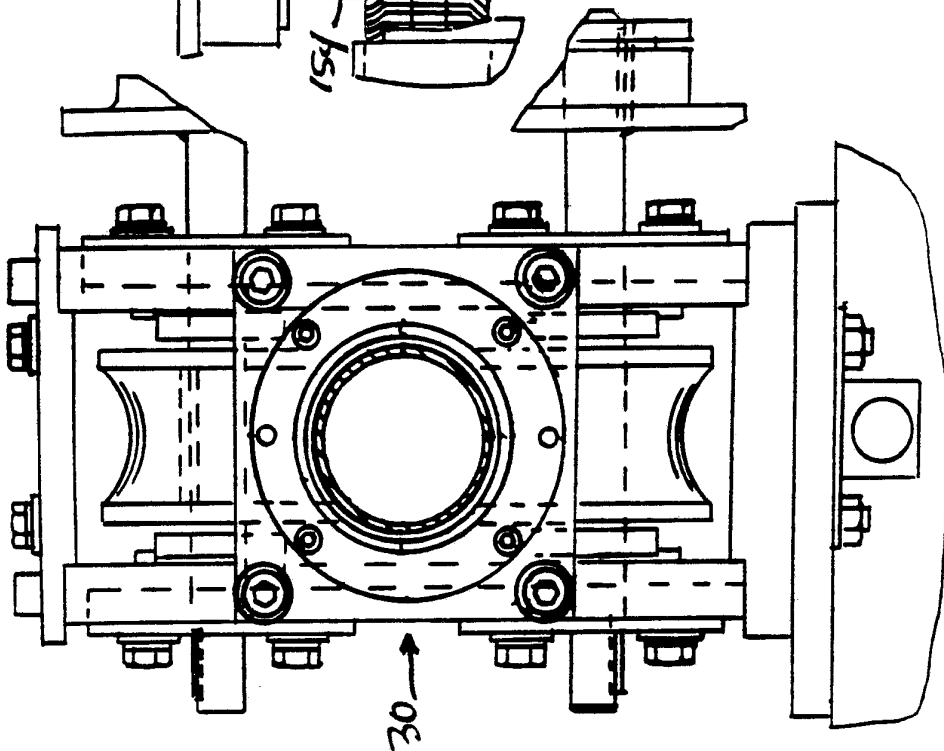

Fig. 29



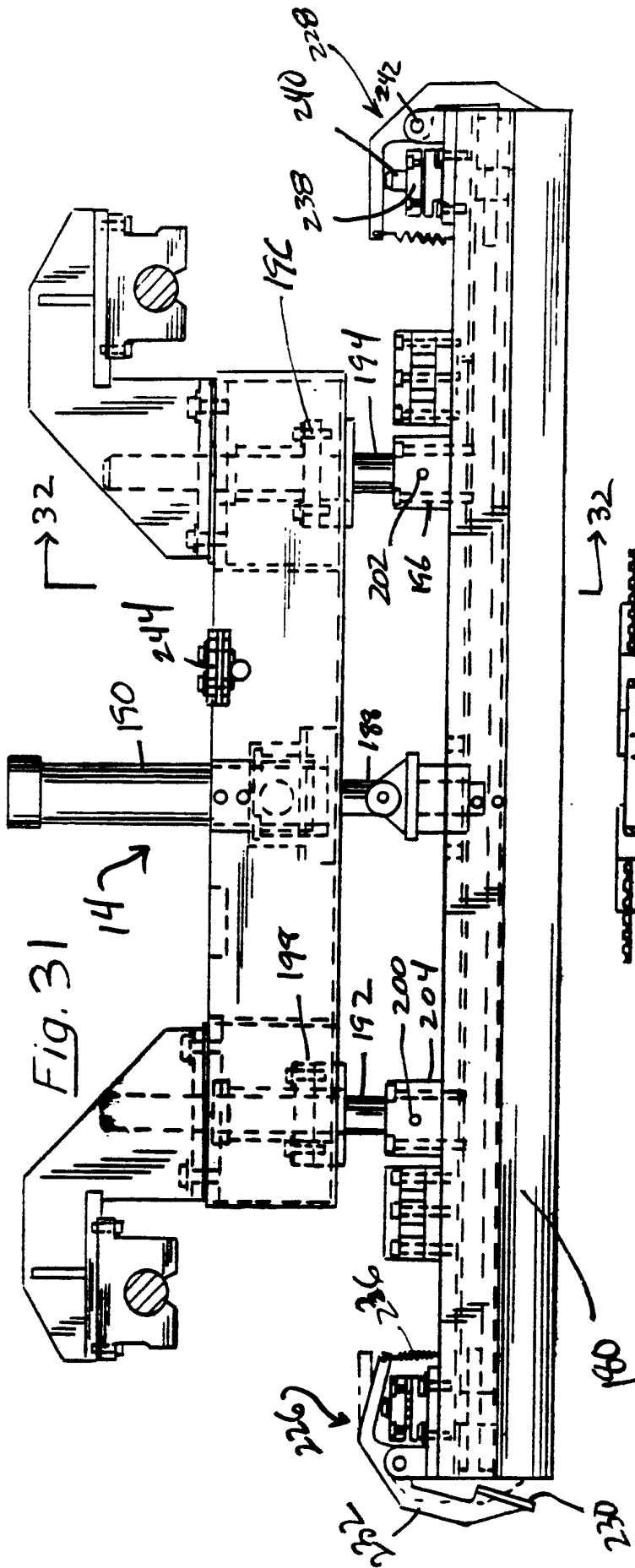

Fig. 31

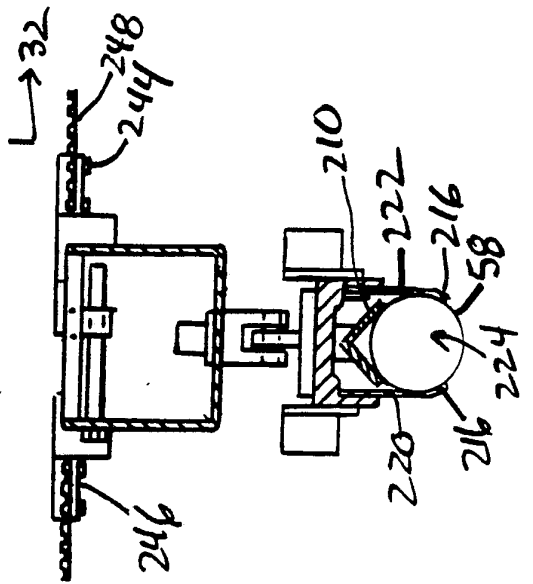

Fig. 32

FIG 33

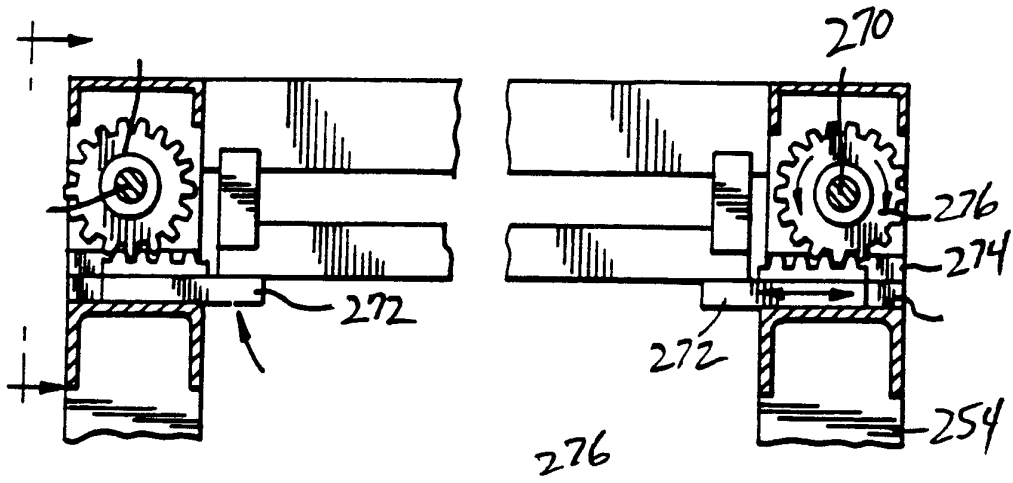

FIG 34

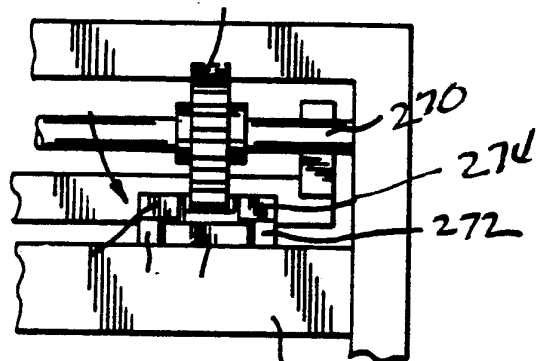

FIG 35

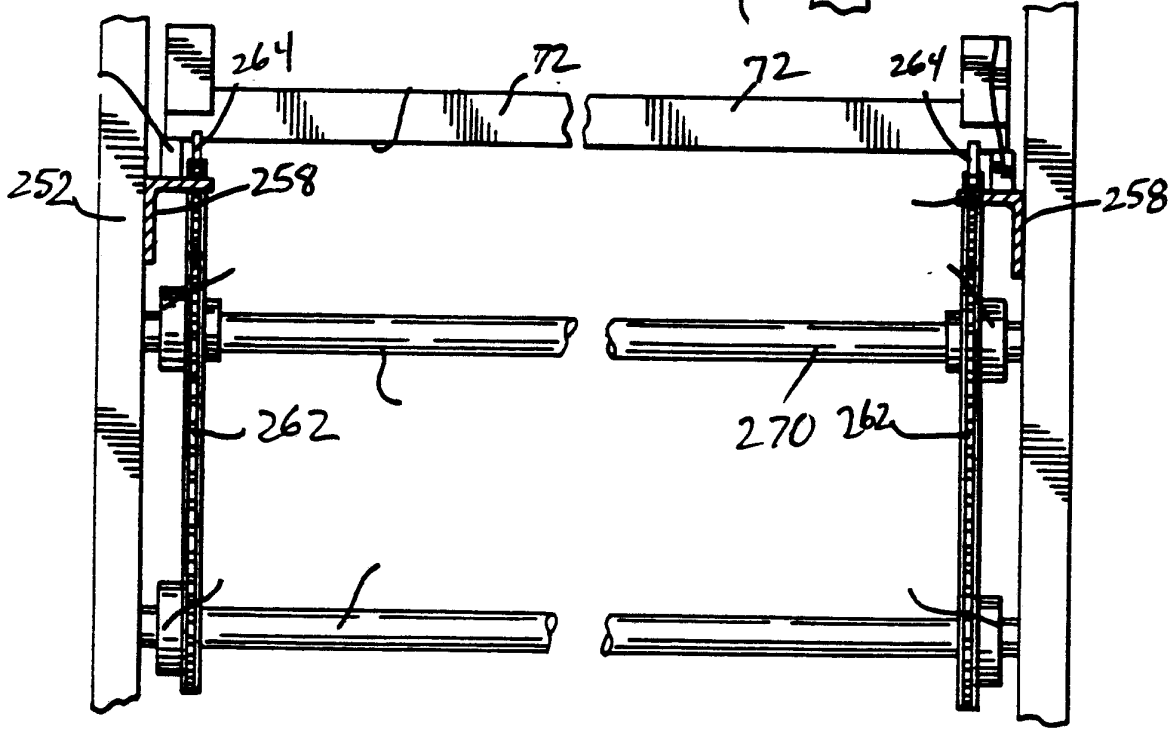
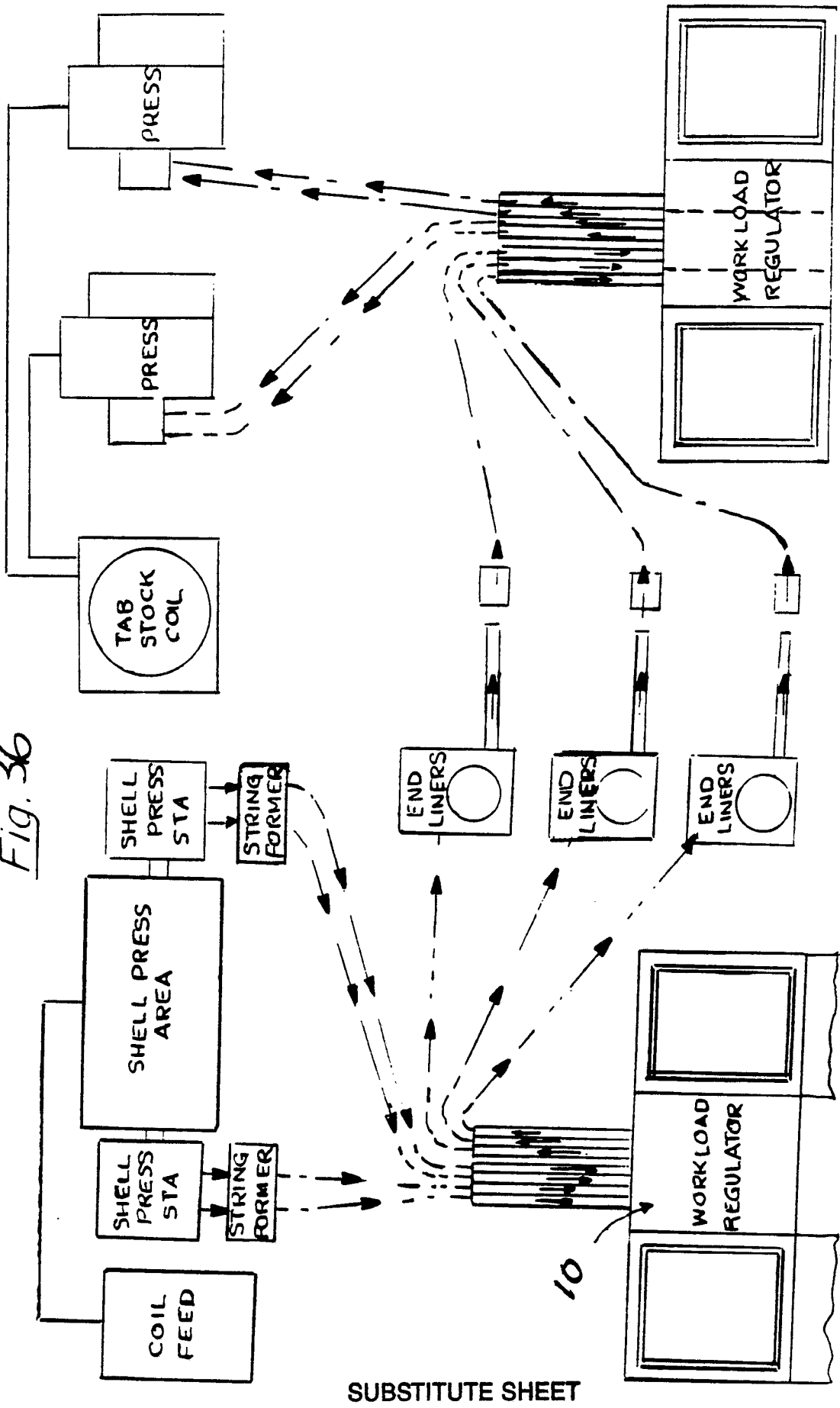

Fig. 36



# INTERNATIONAL SEARCH REPORT

International Application No. **PCT/US92/02110**

**I. CLASSIFICATION OF SUBJECT MATTER** (If several classification symbols apply, indicate all) \*

According to International Patent Classification (IPC) or to both National Classification and IPC  
**IPC(5) B65G 1/04**  
**U.S. CL: 414/416**

**II. FIELDS SEARCHED**

Minimum Documentation Searched \*

Classification System

Classification Symbols

U.S.	414/331, 403, 416, 795.6, 798.9; 198/419.1
------	--

Documentation Searched other than Minimum Documentation  
to the Extent that such Documents are Included in the Fields Searched \*

**III. DOCUMENTS CONSIDERED TO BE RELEVANT \***

Category *	Citation of Document, ** with indication, where appropriate, of the relevant passages †	Relevant to Claim No. ‡
Y	CH, A, 476,598 (SCHWEIZERISCHE INDUSTRIE-GESELLSCHAFT) 30 September 1969, (See Fig. 2)	2
A	US, A, 3,826,348 (PREISIG ET AL) 30 July 1974	
A	US, A, 4,610,346 (PHILLIPSORO) 09 September 1986	
<u>X</u> <u>Y</u>	US, A, 4,808,057 (CHIAPPE ET AL) 28 February 1989, (See entire document)	<u>1</u> 2,4
A	US, A, 4,946,340 (MURPHY ET AL) 07 August 1990	
Y	US, A, 4,979,870 (MOJDEN ET AL) 25 December 1990, (See Fig. 18)	4

\* Special categories of cited documents: †

- "A" document defining the general state of the art which is not considered to be of particular relevance
- "E" earlier document but published on or after the international filing date
- "L" document which may throw doubts on priority claim(s) or which is cited to establish the publication date of another citation or other special reason (as specified)
- "O" document referring to an oral disclosure, use, exhibition or other means
- "P" document published prior to the international filing date but later than the priority date claimed

- "T" later document published after the international filing date or priority date and not in conflict with the application but cited to understand the principle or theory underlying the invention
- "X" document of particular relevance; the claimed invention cannot be considered novel or cannot be considered to involve an inventive step
- "Y" document of particular relevance; the claimed invention cannot be considered to involve an inventive step when the document is combined with one or more other such documents, such combination being obvious to a person skilled in the art.
- "Z" document member of the same patent family

**IV. CERTIFICATION**

Date of the Actual Completion of the International Search

04 May 1992

Date of Making of this International Search Report

**19 JUN 1992**

International Searching Authority

ISA/US

Signature of Authorized Officer

David A. Bucci

