

(19) World Intellectual Property Organization
International Bureau



(43) International Publication Date
1 October 2009 (01.10.2009)

(10) International Publication Number
WO 2009/118279 A1

- (51) International Patent Classification:
B60S 1/38 (2006.01)
- (21) International Application Number:
PCT/EP2009/053350
- (22) International Filing Date:
23 March 2009 (23.03.2009)
- (25) Filing Language: English
- (26) Publication Language: English
- (30) Priority Data:
08103124.7 28 March 2008 (28.03.2008) EP
- (71) Applicant (for all designated States except US): **FEDERAL-MOGUL S.A.** [BE/BE]; Avenue Champion, B-6790 Aubange (BE).
- (72) Inventor; and
- (75) Inventor/Applicant (for US only): **BOLAND, Xavier** [BE/BE]; 304, Route de Luxembourg, B-6700 Arlon (BE).
- (74) Agent: **HOOIVELD, Arjen Jan Winfried**; Sweelinckplein 1, NL-2517 GK Den Haag (NL).

- (81) Designated States (unless otherwise indicated, for every kind of national protection available): AE, AG, AL, AM, AO, AT, AU, AZ, BA, BB, BG, BH, BR, BW, BY, BZ, CA, CH, CN, CO, CR, CU, CZ, DE, DK, DM, DO, DZ, EC, EE, EG, ES, FI, GB, GD, GE, GH, GM, GT, HN, HR, HU, ID, IL, IN, IS, JP, KE, KG, KM, KN, KP, KR, KZ, LA, LC, LK, LR, LS, LT, LU, LY, MA, MD, ME, MG, MK, MN, MW, MX, MY, MZ, NA, NG, NI, NO, NZ, OM, PG, PH, PL, PT, RO, RS, RU, SC, SD, SE, SG, SK, SL, SM, ST, SV, SY, TJ, TM, TN, TR, TT, TZ, UA, UG, US, UZ, VC, VN, ZA, ZM, ZW.
- (84) Designated States (unless otherwise indicated, for every kind of regional protection available): ARIPO (BW, GH, GM, KE, LS, MW, MZ, NA, SD, SL, SZ, TZ, UG, ZM, ZW), Eurasian (AM, AZ, BY, KG, KZ, MD, RU, TJ, TM), European (AT, BE, BG, CH, CY, CZ, DE, DK, EE, ES, FI, FR, GB, GR, HR, HU, IE, IS, IT, LT, LU, LV, MC, MK, MT, NL, NO, PL, PT, RO, SE, SI, SK, TR), OAPI (BF, BJ, CF, CG, CI, CM, GA, GN, GQ, GW, ML, MR, NE, SN, TD, TG).

Published:

— with international search report (Art. 21(3))

(54) Title: WINDSCREEN WIPER DEVICE COMPRISING AN ELASTIC, ELONGATED CARRIER ELEMENT, AS WELL AS AN ELONGATED WIPER BLADE OF A FLEXIBLE MATERIAL, WHICH CAN BE PLACED IN ABUTMENT WITH THE WINDSCREEN TO BE WIPED

FIG. 2

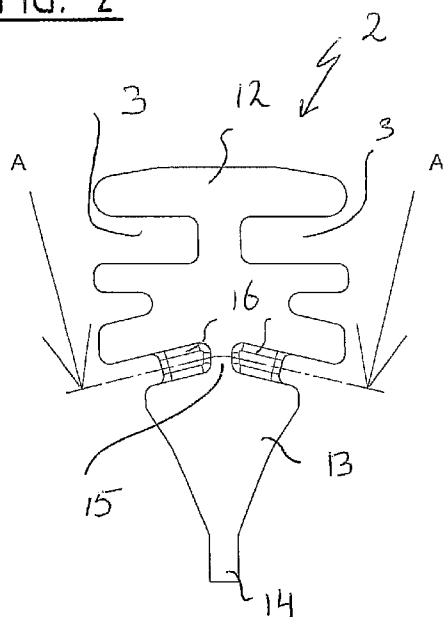

(57) Abstract: A windscreen wiper device (1) comprising carrier element, as well as wiper blade (2), including at least one longitudinal groove (3), in which groove a longitudinal strip (4) of the carrier element is disposed, said windscreen wiper device (1) comprises a connecting device (7) for an oscillating arm (8), wherein said wiper blade (2) comprises an elongated upper holding part (12) and an elongated lower wiping part (13) of a flexible material, wherein said holding part (12) holds said longitudinal strip (4), wherein said wiping part (13) comprises a wiping lip (14), and wherein said holding part (12) and said wiping part (13) are interconnected by means of a tilting web (15), with the special feature that a noise dampening profile (17) is provided in slits (16) formed between said holding part (12), said wiping part (13) and said tilting web (15), wherein a width of said noise dampening profile (17) extending in a direction transverse to the longitudinal direction of said wiper blade (2) varies along said longitudinal direction.

WO 2009/118279 A1

**WINDSCREEN WIPER DEVICE COMPRISING AN ELASTIC, ELONGATED
CARRIER ELEMENT, AS WELL AS AN ELONGATED WIPER BLADE OF A
5 FLEXIBLE MATERIAL, WHICH CAN BE PLACED IN ABUTMENT WITH THE
WINDSCREEN TO BE WIPED**

The invention relates to a windscreen wiper device
comprising an elastic, elongated carrier element, as well as
10 an elongated wiper blade, which can be placed in abutment
with a windscreen to be wiped, which wiper blade includes at
least one longitudinal groove, in which groove a
longitudinal strip of the carrier element is disposed,
wherein ends of said longitudinal strip are connected to a
15 respective connecting piece, which windscreen wiper device
comprises a connecting device for an oscillating arm,
wherein said wiper blade comprises an elongated upper
holding part and an elongated lower wiping part of a
flexible material, wherein said holding part holds said
20 longitudinal strip, wherein said wiping part comprises a
wiping lip, and wherein said holding part and said wiping
part are interconnected by means of a tilting web.

Such a windscreen wiper device is generally known. The prior
25 art windscreen wiper device is in particular designed as a
"yokeless" wiper device or "flat blade", wherein use is no
longer made of several yokes pivotally connected to each
other, but wherein the wiper blade is biased by the carrier
element, as a result of which it exhibits a specific
30 curvature. The holding part, the wiping part and the tilting
web of the known windscreen wiper device are made in one
piece.

A disadvantage of the known windscreen wiper device is the following. In practice said oscillating arm is connected to a mounting head fixed for rotation to a shaft driven by a small motor. In use, the shaft rotates alternately in a clockwise and in a counter-clockwise sense carrying the mounting head into rotation also, which in turn draws said oscillating arm into rotation and by means of said connecting device moves said wiper blade. The tilting web acts as an intermediate part subjected to a force in accordance with the wiping direction. Said force acts solely on said tilting web, so that the wiping lip attached to said wiping part is guided in opposite direction to the wiping direction. Particularly, said tilting web is strip-shaped, whereas said wiping lip is triangular in shape. However, the oscillatory movement of said wiping lip along the windscreen to be wiped results in a significant "rattling" noise or reversal noise, particularly as a consequence of said wiping lip being tumbled over at each turning point of its oscillatory movement.

It is an object of the invention to improve the prior art, that is to provide a windscreen wiper device wherein the above disadvantage is obviated at minimum costs.

It is noted that the present invention is not restricted to windscreen wiper devices for cars, but that it also relates to windscreen wiper devices for rail coaches and all other (fast) vehicles.

In order to accomplish that objective, a windscreen wiper device of the kind referred to in the introduction according

to the invention is characterized in that a noise dampening profile is provided in slits formed between said holding part, said wiping part and said tilting web, wherein a width of said noise dampening profile extending in a direction
5 transverse to the longitudinal direction of said wiper blade varies along said longitudinal direction. Particularly, said width at the location of said connecting device is larger than said width at the location of said connecting pieces. The present invention is particularly based on the awareness
10 that variation of said width of said noise dampening profile may compensate the variation of the pressure as exerted on said wiper blade by said oscillating arm. Dependent on the actual construction of the present windscreen wiper device, said pressure may be larger at the location of the
15 connection of said oscillating arm onto said wiper blade (that is at the location of said connecting device), all compared to said pressure at the ends of said longitudinal strip (that is at the location of the respective connecting pieces). By varying the width of the noise dampening profile
20 in accordance with the normal variation in pressure exerted on the wiper blade, the actual pressure exerted on the wiper blade by the oscillating arm is more or less constant, seen along the length of the wiper blade, resulting in less noise.

25

In one preferred embodiment of a windscreen wiper device according to the invention, said width gradually decreases from the location of said connecting device to the location of said connecting pieces.

30

In another preferred embodiment of a windscreen wiper device in accordance with the invention, said noise dampening profile in each slit is formed by spaced-apart protrusions

extending outwardly from said tilting web. Preferably, said protrusions extend outwardly from said tilting web to the middle of each slit. Experiments have shown that the noise caused by said wiping lip being swung over at each turning point of its oscillatory movement, is then minimal.

In another preferred embodiment of a windscreen wiper device according to the invention, said protrusions on opposite sides of said tilting web are located opposite one another in said slits. In the alternative, said protrusions are located on opposite sides of said tilting web in a staggered manner in said slits.

In another preferred embodiment of a windscreen wiper device in accordance with the invention, the width of said protrusions at the location of said connecting device is chosen within the range of 0,7 mm and 2,2 mm. Preferably, the width of said protrusions at the location of said connecting pieces is chosen within the range of 0,1 mm and 1,2 mm.

In another preferred embodiment of a windscreen wiper device according to the invention, said tilting web and said noise dampening profile are made in one piece. Particularly, said wiper blade is made in one piece of elastomer material, that is that said holding part, said wiping part, said tilting web and said noise dampening profile are integral.

The invention will now be explained in more detail with reference to figures illustrated in a drawing, wherein:

- figure 1 is a total perspective, schematic view of a windscreen wiper device according to the invention;

- 5 - figure 2a is a cross-sectional view of a wiper blade as used in the windscreen wiper device of figure 1, while figure 2b is a longitudinal view along the lines A, B, C, D, E, F of figure 2a;
- 10 - figure 3 corresponds to figure 2, but now referring to another preferred embodiment; and
- 15 - figure 4 shows a relationship between the width of a noise dampening profile measured along the y-axis and the length of a wiper blade along the x-axis according to the invention.

15

Figure 1 shows a preferred variant of a windscreen wiper device 1 according to the invention. Said windscreen wiper device is built up of an elastomeric wiper blade 2, in the longitudinal sides of which opposing longitudinal grooves 3 are formed, and of longitudinal strips 4 made of spring band steel, which are fitted in said longitudinal grooves 3. Said strips 4 form a flexible carrier element for the rubber wiper blade 2, as it were, which is thus biased in a curved position (the curvature in operative position being that of a windscreen to be wiped). Neighbouring ends 5 of strips 4 are interconnected on either side of the windscreen wiper device 1 by means of connecting pieces 6 functioning as clamping members. In this embodiment, the connecting pieces 6 are separate constructional elements, which may be form-locked as well as force-locked to the ends 5 of strips 4. In another preferred variant, said connecting pieces 6 are in one piece with the strips 4 made of spring band steel. In

the latter case said connecting pieces form transverse bridges for the strips 4, as it were. The windscreen wiper device 1 is furthermore built up of a connecting device 7 of plastic or metallic material for an oscillating wiper arm 8.

5 Connecting device 7 comprises clamping members 9 that are integral therewith, which engage round longitudinal sides of the strips 4 that face away from each other, as a result of which the connecting device 7 is firmly attached to the unit consisting of wiper blade 2 and strips 4. The oscillating

10 wiper arm 8 is pivotally connected to the connecting device 7 about a pivot axis near one end. The preferred embodiment of figure 5 according to the invention comprises a spoiler or "air deflector" 10 including two separate sub-spoilers 11. Each sub-spoiler 11 is detachably connected in its

15 entirety to the wiper blade 2 on opposite sides of the connecting device 7.

In figure 2a a cross-sectional view of the wiper blade of figure 1 is shown, wherein corresponding parts have been

20 designated with the same reference numerals. As can be seen from figure 2a, said rubber wiper blade 2 consists of an elongated upper holding part 12 holding said longitudinal strips 4 in said grooves 3 formed therein, an elongated lower wiping part 13 having a wiping lip 14, as well as an

25 intermediate "strip-like" titling web 15 interconnecting said holding part 12 and said wiping part 13. Again, said holding part 12, said wiping part 13 and said tilting web 15 are in one piece of rubber. Said tilting web 15 defines slits or grooves 16 on opposite sides thereof.

Although not shown in figures 1 and 2, but fully understood by a skilled person, said oscillating arm 8 is connected to a mounting head fixed for rotation to a shaft driven by a small motor. In use, the shaft rotates alternately in a clockwise and in a counter-clockwise sense carrying the mounting head into rotation also, which in turn draws said oscillating arm 8 into rotation and by means of said connecting device 7 moves said wiper blade 2. The tilting web 15 then acts as an intermediate part subjected to a force in accordance with the wiping direction. Said force acts solely on said tilting web 15, so that the wiping lip 14 attached to said wiping part 13 is guided in opposite direction to the wiping direction. As already explained above, the oscillatory movement of said wiping lip 14 along the windscreen to be wiped results in a "rattling" noise (that is a so-called "reversal noise"), particularly as a consequence of said wiping lip 14 being tumbled over at each turning point of its oscillatory movement. In order to reduce said noise a noise dampening profile is provided in said slits 16, wherein said noise dampening profile in each slit is formed by spaced-apart protrusions 17 extending outwardly from said tilting web 15. The width of said protrusions 17 extending in a direction transverse to the longitudinal direction of said wiper blade 2 varies along said longitudinal direction, in the sense that the width of said protrusions 17 at the location of said connecting device 7 is larger than the width of the protrusions 17 at the location of said connecting pieces 6. More precisely, with reference to figure 2b, the width of said protrusion 17 at the location A (for example, at the ends 5 of the strips 4) is smaller than the width of said protrusion 17 at the location B; the width of said protrusion 17 at the location B is smaller than the width of said protrusion 17 at the

location C; the width of said protrusion 17 at the location C is smaller than the width of said protrusion 17 at the location D; the width of said protrusion 17 at the location D is smaller than the width of said protrusion 17 at the location E; the width of said protrusion 17 at the location E is smaller than the width of said protrusion 17 at the location F. In other words, $A > B > C > D > E > F$. Thus, the width of the protrusions 17 decreases along the length of the wiper blade 2, seen from the connecting device 7 to the opposite connecting pieces 6. As seen from figure 2b, said protrusions 17 on opposite sides of said tilting web 15 are located in a staggered manner in said slits 16.

Figures 3a and 3b correspond to figures 6a and 7a, respectively, with the difference that a corresponding noise dampening profile has been provided in upper slits 18 on opposite sides of an upper tilting web 19. The tilting web 15 and the slits 16 may then be called lower tilting web 15 and lower slits 16, respectively. As can be seen from figure 3b at the bottom, this extra noise dampening profile consists of corresponding protrusions 20 extending outwardly from said tilting web 19 on opposite sides thereof in a staggered manner. As far as the width of the protrusions 18 is concerned, again applies $A > B > C > D > E > F$. The width of the protrusions 18 thus again decreases along the length of the wiper blade 2, seen from the connecting device 7 to the opposite connecting pieces 6.

As can be seen in figure 4, the width of the protrusions 17, 20 (plotted along the y-axis) may vary along the length of the wiper blade 2 measured along the x-axis in several ways: for example, said width gradually decreases from the location x of said connecting device 7 to the location y of

said connecting pieces 6 (see curve 21) or said width varies along curve 22 in the sense that said width at the location x of said connecting device 7 is larger than said width at the location y of said connecting pieces 6, but said width is smallest inbetween.

The invention is not restricted to the embodiments shown, but also extends to other preferred embodiments falling within the scope of the appended claims.

CLAIMS

1. A windscreen wiper device comprising an elastic,
elongated carrier element, as well as an elongated
5 wiper blade, which can be placed in abutment with a
windscreen to be wiped, which wiper blade includes at
least one longitudinal groove, in which groove a
longitudinal strip of the carrier element is disposed,
wherein ends of said longitudinal strip are connected
10 to a respective connecting piece, which windscreen
wiper device comprises a connecting device for an
oscillating arm, wherein said wiper blade comprises an
elongated upper holding part and an elongated lower
wiping part of a flexible material, wherein said
15 holding part holds said longitudinal strip, wherein
said wiping part comprises a wiping lip, and wherein
said holding part and said wiping part are
interconnected by means of a tilting web, characterized
in that a noise dampening profile is provided in slits
20 formed between said holding part, said wiping part and
said tilting web, wherein a width of said noise
dampening profile extending in a direction transverse
to the longitudinal direction of said wiper blade
varies along said longitudinal direction.
- 25
2. A windscreen wiper device according to claim 1, wherein
said width at the location of said connecting device is
larger than said width at the location of said
connecting pieces.
- 30
3. A windscreen wiper device according to claim 2, wherein
said width gradually decreases from the location of

said connecting device to the location of said connecting pieces.

- 5 4. A windscreen wiper device according to claim 1, 2 or 3, wherein said noise dampening profile in each slit is formed by spaced-apart protrusions extending outwardly from said tilting web.
- 10 5. A windscreen wiper device according to claim 4, wherein said protrusions extend outwardly from said tilting web to the middle of each slit.
- 15 6. A windscreen wiper device according to claim 4 or 5, wherein said protrusions on opposite sides of said tilting web are located opposite one another in said slits.
- 20 7. A windscreen wiper device according to claim 4 or 5, wherein said protrusions on opposite sides of said tilting web are located in a staggered manner in said slits.
- 25 8. A windscreen wiper device according to any of the preceding claims 4 through 7, wherein the width of said protrusions at the location of said connecting device is chosen within the range of 0,7 mm and 2,2 mm.
- 30 9. A windscreen wiper device according to any of the preceding claims 4 through 8, wherein the width of said protrusions at the location of said connecting pieces is chosen within the range of 0,1 mm and 1,2 mm.

- 10 A windshield wiper device according to any of the preceding claims 1 through 9, wherein said tilting web and said noise dampening profile are made in one piece.
- 5 11 A windshield wiper device according to any of the preceding claims 1 through 10, wherein said dampening profile is provided in upper slits on opposite sides of an upper tilting web of said wiper blade, as well as in lower slits on opposite sides of a lower tilting web of
- 10 said wiper blade.

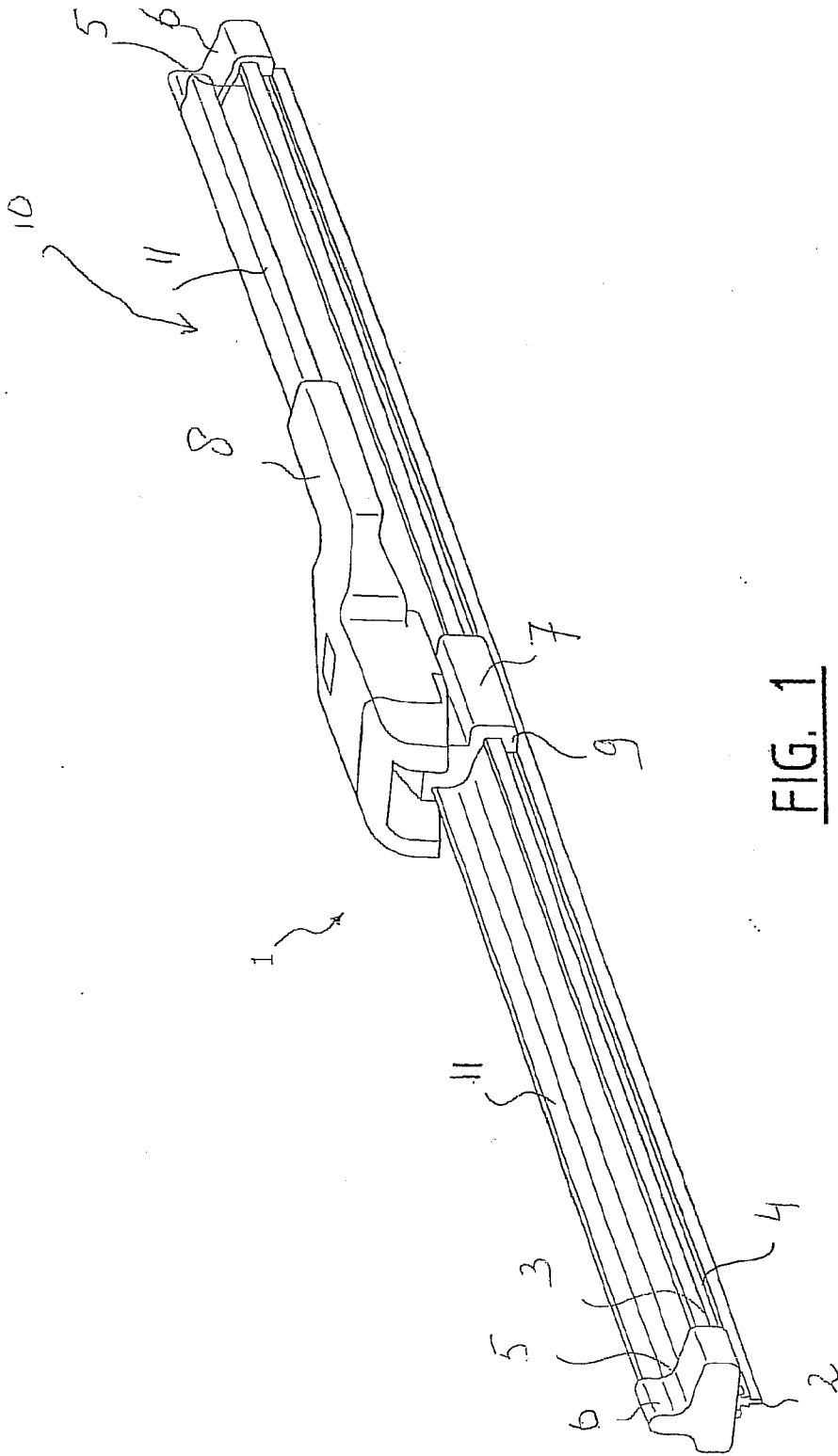
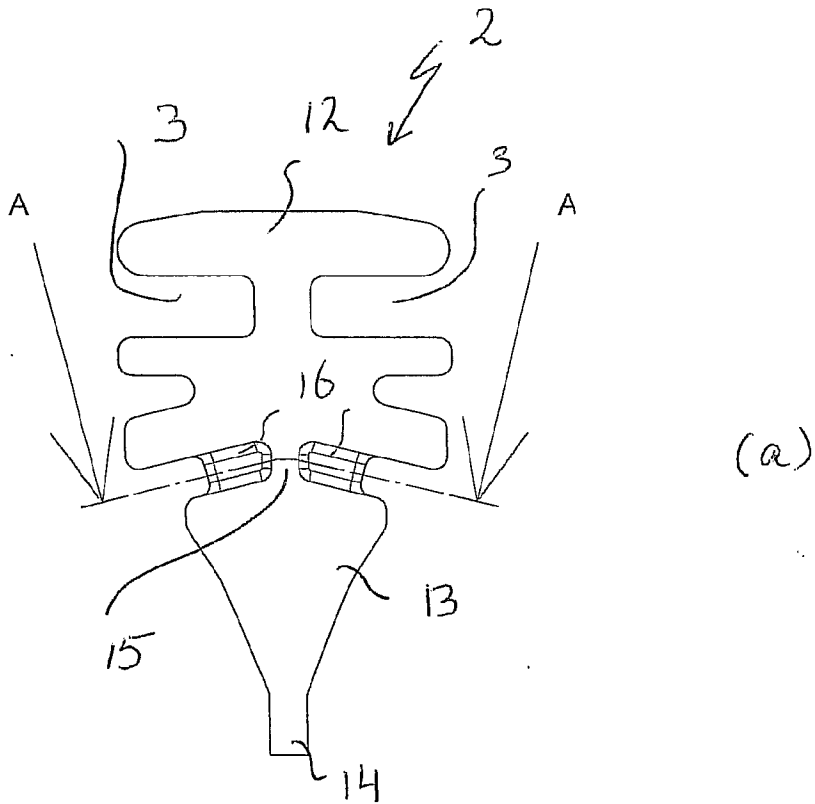

FIG. 1



(a)

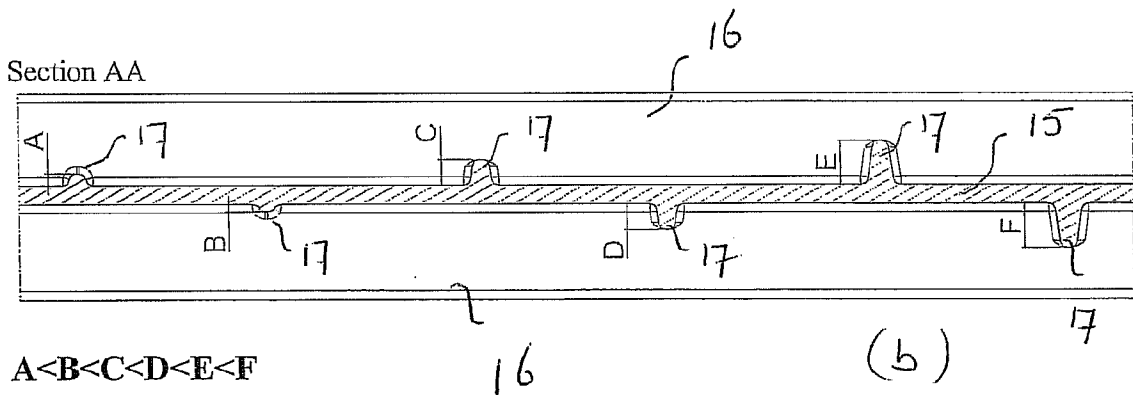

FIG. 2

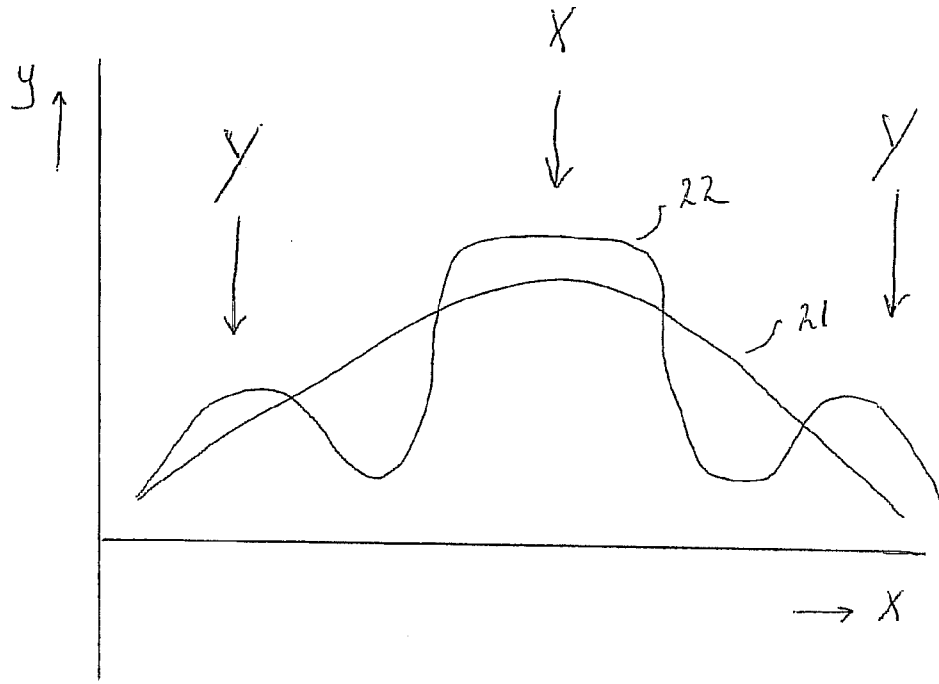

FIG. 4

INTERNATIONAL SEARCH REPORT

International application No
PCT/EP2009/053350

A. CLASSIFICATION OF SUBJECT MATTER
INV. B60S1/38

According to International Patent Classification (IPC) or to both national classification and IPC

B. FIELDS SEARCHED

Minimum documentation searched (classification system followed by classification symbols)
B60S

Documentation searched other than minimum documentation to the extent that such documents are included in the fields searched

Electronic data base consulted during the international search (name of data base and, where practical, search terms used)

EPO-Internal

C. DOCUMENTS CONSIDERED TO BE RELEVANT

| Category* | Citation of document, with indication, where appropriate, of the relevant passages | Relevant to claim No. |
|-----------|---|-----------------------|
| X | FR 2 867 738 A (VOLKSWAGEN AG [DE]) 23 September 2005 (2005-09-23) page 7, line 23 - page 10, line 8; figures | 1,4,5, 7-11 |
| Y | ----- | 6 |
| Y | DE 10 2004 050163 A1 (VOLKSWAGEN AG [DE]; BOSCH GMBH ROBERT [DE]) 27 April 2006 (2006-04-27) paragraph [0021] - paragraph [0032]; figures | 6 |
| A | ----- | 7-9 |
| A | US 3 414 930 A (MITSURU KODAMA) 10 December 1968 (1968-12-10) column 2, line 14 - column 6, line 11; figures | 1,2 |

Further documents are listed in the continuation of Box C. See patent family annex.

* Special categories of cited documents :

| | |
|---|---|
| *A* document defining the general state of the art which is not considered to be of particular relevance | *T* later document published after the international filing date or priority date and not in conflict with the application but cited to understand the principle or theory underlying the invention |
| *E* earlier document but published on or after the international filing date | *X* document of particular relevance; the claimed invention cannot be considered novel or cannot be considered to involve an inventive step when the document is taken alone |
| *L* document which may throw doubts on priority claim(s) or which is cited to establish the publication date of another citation or other special reason (as specified) | *Y* document of particular relevance; the claimed invention cannot be considered to involve an inventive step when the document is combined with one or more other such documents, such combination being obvious to a person skilled in the art. |
| *O* document referring to an oral disclosure, use, exhibition or other means | *Z* document member of the same patent family |
| *P* document published prior to the international filing date but later than the priority date claimed | |

| | |
|---|--|
| Date of the actual completion of the international search | Date of mailing of the international search report |
| 7 May 2009 | 18/05/2009 |

| | |
|--|---|
| Name and mailing address of the ISA/ European Patent Office, P.B. 5818 Patentlaan 2 NL - 2280 HV Rijswijk Tel. (+31-70) 340-2040, Fax: (+31-70) 340-3016 | Authorized officer Sangiorgi, Massimo |
|--|---|

INTERNATIONAL SEARCH REPORT

Information on patent family members

| |
|--|
| International application No PCT/EP2009/053350 |
|--|

| Patent document cited in search report | | Publication date | Patent family member(s) | Publication date |
|--|----|------------------|---|--|
| FR 2867738 | A | 23-09-2005 | NONE | |
| DE 102004050163 | A1 | 27-04-2006 | AT 426531 T CN 101039825 A EP 1802497 A1 WO 2006040259 A1 JP 2008516828 T US 2008178409 A1 | 15-04-2009 19-09-2007 04-07-2007 20-04-2006 22-05-2008 31-07-2008 |
| US 3414930 | A | 10-12-1968 | NONE | |