



- (51) International Patent Classification:
B64C 39/00 (2006.01) *B64D 1/12* (2006.01)
B64C 35/02 (2006.01)
- (21) International Application Number:
PCT/IL2018/050614
- (22) International Filing Date:
06 June 2018 (06.06.2018)
- (25) Filing Language: English
- (26) Publication Language: English
- (30) Priority Data:
252808 11 June 2017 (11.06.2017) IL
- (71) Applicant: SPEAR U.A.V LTD [IL/IL]; 5 HATET ZAYIN ST., 6927605 TEL AVIV (IL).
- (72) Inventor: KUPERMAN, Gedalia; 5 HATET ZAYIN ST., 6927605 TEL AVIV (IL).
- (74) Agent: BACHAR, Almog; 5 HAYARKON ST., 4032137 KFAR YONA (IL).
- (81) Designated States (*unless otherwise indicated, for every kind of national protection available*): AE, AG, AL, AM, AO, AT, AU, AZ, BA, BB, BG, BH, BN, BR, BW, BY, BZ, CA, CH, CL, CN, CO, CR, CU, CZ, DE, DJ, DK, DM, DO, DZ, EC, EE, EG, ES, FI, GB, GD, GE, GH, GM, GT, HN, HR, HU, ID, IL, IN, IR, IS, JO, JP, KE, KG, KH, KN, KP, KR, KW, KZ, LA, LC, LK, LR, LS, LU, LY, MA, MD, ME, MG, MK, MN, MW, MX, MY, MZ, NA, NG, NI, NO, NZ, OM, PA, PE, PG, PH, PL, PT, QA, RO, RS, RU, RW, SA, SC, SD, SE, SG, SK, SL, SM, ST, SV, SY, TH, TJ, TM, TN, TR, TT, TZ, UA, UG, US, UZ, VC, VN, ZA, ZM, ZW.
- (84) Designated States (*unless otherwise indicated, for every kind of regional protection available*): ARIPO (BW, GH, GM, KE, LR, LS, MW, MZ, NA, RW, SD, SL, ST, SZ, TZ, UG, ZM, ZW), Eurasian (AM, AZ, BY, KG, KZ, RU, TJ, TM), European (AL, AT, BE, BG, CH, CY, CZ, DE, DK, EE, ES, FI, FR, GB, GR, HR, HU, IE, IS, IT, LT, LU, LV,

(54) Title: LAUNCHED UNMANNED AERIAL VEHICLE

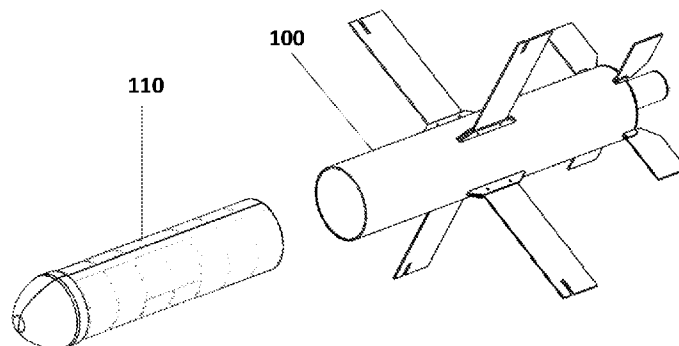

Fig. 2

(57) Abstract: A system for launching an Unmanned Aerial Vehicle (UAV), comprising: a capsule comprising at least two parts; a UAV configured to be encapsulated inside the capsule in a folded configuration; and an aerial carrier comprising a release mechanism, the carrier configured to carry the capsule; the carrier further configured to be launched and eject the capsule upon arrival at a desired aerial location, using the release mechanism; wherein prior to the ejection, the carrier is further configured to execute vertical maneuvers in order to reduce the carrier's speed and change the carrier's angle thereby creating suitable conditions for the capsule's ejection; the capsule configured to split and release the UAV upon being ejected; and the ejected UAV further configured to unfold upon release from the capsule.



MC, MK, MT, NL, NO, PL, PT, RO, RS, SE, SI, SK, SM,
TR), OAPI (BF, BJ, CF, CG, CI, CM, GA, GN, GQ, GW,
KM, ML, MR, NE, SN, TD, TG).

Published:

— *with international search report (Art. 21(3))*

LAUNCHED UNMANNED AERIAL VEHICLE

FIELD OF THE INVENTION

The present invention generally relates to Unmanned Aerial Vehicles (UAV) and specifically to long distance launched UAVs.

5 CROSS-REFERENCE TO RELATED PATENT APPLICATIONS

This patent application claims priority from and is related to IL Patent Application Serial Number 252808, filed 11/Jun/2017, this IL Patent Application incorporated by reference in its entirety herein.

BACKGROUND

10 Conventional land-launched Unmanned Aerial Vehicles (UAVs) are used for various purposes, as a hobby or for operational missions such as delivery, surveillance, observation, etc. The everlasting problem with existing UAVs such as multi rotor copters or drones is that they have a limited range of operation due to their limited power capacities leading to a relatively short flight time thus, when a UAV is intended to
15 perform a long distance operation, the UAV's battery cannot provide the necessary flight time.

Conventional, land-launched UAVs have limited endurance capabilities in accordance with their limited power capacities.

Arrival time for distant targets (at a range of several kilometers) using conventional
20 UAVs may be very long, while the usage of a UAV that is launched from a "carrier" significantly reduces the arrival time.

Therefore, there is a need for a UAV that can be launched to a long distance location whereby it is released to perform its mission.

SUMMARY

According to an aspect of the present invention there is provided a system for launching an Unmanned Aerial Vehicle (UAV), comprising: a capsule comprising at least two parts; a UAV configured to be encapsulated inside the capsule in a folded configuration; and an aerial carrier comprising a release mechanism, the carrier configured to carry the capsule; the carrier further configured to be launched and eject the capsule upon arrival at a desired aerial location, using the release mechanism; wherein prior to the ejection, the carrier is further configured to execute vertical maneuvers in order to reduce the carrier's speed and change the carrier's angle thereby creating suitable conditions for the capsule's ejection; the capsule configured to split and release the UAV upon being ejected; and the ejected UAV further configured to unfold upon release from the capsule.

The carrier may be selected from the group consisting of glider bombs, rockets, RPV (remote-piloted vehicle), UAVs and mortar shells.

The capsule may be shaped according to the UAV's contour.

The inner side of the capsule may further comprise supports configured to tightly hold the UAV.

The carrier's speed may be substantially zero and the carrier's angle may be between 70 to 90 degrees relative to the ground.

The release mechanism may be one of a pneumatic mechanism and at least one spring.

The release mechanism may be a pyrotechnic mechanism; and wherein the capsule may further comprise a sealing layer configured to create a sealed cavity between the pyrotechnic mechanism and the capsule thereby enabling pressure created by the pyrotechnic mechanism to eject the capsule.

The capsule may further comprise springs mounted between the at least two capsule's parts; the springs configured to assist the capsule to split.

The UAV may be a drone comprising at least two arms.

Each arm may comprise an engine controller and a propeller.

Each arm may comprise at least one spring configured to unfold its respective arm upon release from the capsule.

- 5 The at least one spring may be disposable and configured to be discarded upon unfolding of its respective arm.

The UAV may comprise at least one battery; wherein at least one of the at least one battery may be a detachable battery.

- 10 The detachable battery may comprise a physical connector and electrical connectors; and wherein the UAV may further comprise a battery release mechanism and electrical connectors; the battery's electrical connectors configured to be connected to the UAV's electrical connectors; the physical connector configured to be connected to the battery release mechanism; and wherein the battery release mechanism may be configured to release the physical connector upon a signal indicating that the detachable battery
15 should be discarded.

The physical connector may be a screw and the battery release mechanism may be a servo motor; and wherein the servo motor may be configured to rotate and release the screw.

- 20 The battery may further comprise at least one socket configured to press at least one spring against the UAV; the at least one spring may be configured to assist in releasing of the battery.

The battery release mechanism may be one of a pyrotechnic mechanism and a mechanical mechanism.

- 25 According to another aspect of the present invention there is provided a method of launching an Unmanned Aerial Vehicle (UAV), comprising: launching an aerial carrier

comprising a capsule and a release mechanism; the capsule comprises at least two parts and configured to encapsulate a UAV in a folded configuration; executing, by the carrier, vertical maneuvers in order to reduce the carrier's speed and change the carrier's angle thereby creating suitable conditions for ejecting the capsule; ejecting the capsule upon arrival at a desired aerial location, using the release mechanism; splitting the capsule and releasing the UAV upon the ejecting; and unfolding the folded UAV upon the releasing.

The carrier may be selected from the group consisting of glider bombs, rockets, RPV (remote-piloted vehicle), UAVs and mortar shells.

10 The capsule may be shaped according to the UAV's contour.

The inner side of the capsule may further comprise supports configured to tightly hold the UAV.

The carrier's speed may be substantially zero and the carrier's angle may be between 70 to 90 degrees relative to the ground.

15 The release mechanism may be one of a pneumatic mechanism and at least one spring.

The release mechanism may be a pyrotechnic mechanism; and wherein the capsule may further comprise a sealing layer configured to create a sealed cavity between the pyrotechnic mechanism and the capsule thereby enabling pressure created by the pyrotechnic mechanism to eject the capsule.

20 The capsule may further comprise springs mounted between the at least two capsule's parts; the springs configured to assist the capsule to split.

The UAV may be a drone comprising at least two arms.

Each arm may comprise an engine controller and a propeller.

Each arm may comprise at least one spring and wherein the unfolding comprises using the at least one spring for unfolding the respective arm upon the releasing from the capsule.

5 The at least one spring may be disposable and the method may further comprise discarding the at least one spring upon unfolding of its respective arm.

The UAV may comprise at least one battery; wherein at least one of the at least one battery may be a detachable battery.

10 The detachable battery may comprise a physical connector and electrical connectors; and wherein the UAV may further comprise a battery release mechanism and electrical connectors; the battery's electrical connectors are connected to the UAV's electrical connectors; the physical connector is connected to the battery release mechanism; and wherein the method may further comprise releasing, by the battery release mechanism, the physical connector upon a signal indicating that the detachable battery should be discarded.

15 The physical connector may be a screw and the battery release mechanism may be a servo motor; and wherein the releasing may comprise rotating the servo motor and releasing the screw.

20 The battery may further comprise at least one socket configured to press at least one spring against the UAV; the method may further comprise assisting, by the at least one spring, in the releasing of the battery.

The battery release mechanism may be one of a pyrotechnic mechanism and a mechanical mechanism.

25 According to another aspect of the present invention there is provided a system for launching an Unmanned Aerial Vehicle (UAV), comprising: an aerial carrier comprising a release mechanism, the carrier configured to carry a UAV in a folded configuration; the carrier further configured to be launched and eject the folded UAV upon arrival at a

desired aerial location, using the release mechanism; wherein prior to the ejection, the carrier is further configured to execute vertical maneuvers in order to reduce the carrier's speed and change the carrier's angle thereby creating suitable conditions for the UAV's ejection; and the ejected UAV further configured to unfold upon release from the carrier.

The carrier may be selected from the group consisting of glider bombs, rockets, RPV (remote-piloted vehicle), UAVs and mortar shells.

The carrier's speed may be substantially zero and the carrier's angle may be between 70 to 90 degrees relative to the ground.

10 The release mechanism may be one of a pneumatic mechanism and at least one spring.

The UAV may be a drone comprising at least two arms.

Each arm may comprise an engine controller and a propeller.

15 Each arm may comprise at least one spring configured to unfold its respective arm upon release from the carrier.

The at least one spring may be disposable and configured to be discarded upon unfolding of its respective arm.

The UAV may comprise at least one battery; wherein at least one of the at least one battery may be a detachable battery.

20 The detachable battery may comprise a physical connector and electrical connectors; and wherein the UAV may further comprise a battery release mechanism and electrical connectors; the battery's electrical connectors configured to be connected to the UAV's electrical connectors; the physical connector configured to be connected to the battery release mechanism; and wherein the battery release mechanism may be configured to

release the physical connector upon a signal indicating that the detachable battery should be discarded.

The physical connector may be a screw and the battery release mechanism may be a servo motor; and wherein the servo motor may be configured to rotate and release the screw.

The battery may further comprise at least one socket configured to press at least one spring against the UAV; the at least one spring may be configured to assist in releasing of the battery.

The battery release mechanism may be one of a pyrotechnic mechanism and a mechanical mechanism.

BRIEF DESCRIPTION OF THE DRAWINGS

For better understanding of the invention and to show how the same may be carried into effect, reference will now be made, purely by way of example, to the accompanying drawings.

With specific reference now to the drawings in detail, it is stressed that the particulars shown are by way of example and for purposes of illustrative discussion of the preferred embodiments of the present invention only, and are presented in the cause of providing what is believed to be the most useful and readily understood description of the principles and conceptual aspects of the invention. In this regard, no attempt is made to show structural details of the invention in more detail than is necessary for a fundamental understanding of the invention, the description taken with the drawings making apparent to those skilled in the art how the several forms of the invention may be embodied in practice. In the accompanying drawings:

Fig. 1 is a schematic view of an exemplary carrier encompassing the UAV's capsule according to embodiments of the present invention;

Fig. 2 is an exploded view of **Fig. 1**;

Fig. 3 is an exploded view of the capsule encompassing the UAV according to embodiments of the present invention;

Fig. 4 is a schematic view of the UAV's deployment process according to embodiments of the present invention;

Figs. 5A and **5B** are schematic top and bottom perspective views of an exemplary UAV according to embodiments of the present invention;

Fig. 5C is a side view of the exemplary UAV of **Figs. 5A** and **5B** according to embodiments of the present invention;

Fig. 6 is an enlargement of the front end of the UAV of **Figs. 5A** and **5B** according to embodiments of the present invention; and

Fig. 7 is a schematic view of an exemplary detachable battery according to embodiments of the present invention.

15 DETAILED DESCRIPTION OF PREFERRED EMBODIMENTS

Before explaining at least one embodiment of the invention in detail, it is to be understood that the invention is not limited in its application to the details of construction and the arrangement of the components set forth in the following description or illustrated in the drawings. The invention is applicable to other embodiments or of being practiced or carried out in various ways. Also, it is to be understood that the
20 phraseology and terminology employed herein is for the purpose of description and should not be regarded as limiting.

The present invention provides a UAV (Unmanned Aerial Vehicles) that can be launched for long-distance missions from land, sea and air, using an aerial carrier such
25 as standardized launchers, glider bombs, UAVs, rockets, RPV (remote-piloted vehicle), mortar shells, etc. The UAV's dimensions allow for it to be contained, in a folded state, within the inner chamber of the carrier that can be launched to a point of interest in far-off airspace. When the carrier reaches optimal release conditions, the UAV is released, separates from its carrier, unfolds and executes its mission. Upon the conclusion of its

mission, the UAV may either destroy itself, land at a predefined rendezvous point or be directed by an operator.

The present invention's UAVs may be intended to carry out a variety of missions, such as tracking moving targets, night reconnaissance, relaying communications and data,
5 laser designation, measuring atmospheric conditions, search and rescue and more.

Since time is saved on the flight to targets, the UAVs provide a tactical solution for executing long range missions in minimal time, with maximum endurance and payload capabilities.

10 According to embodiments of the present invention, the UAV may be preprogrammed to perform a mission, guided from a distance or a combination of these two methods.

According to embodiments of the present invention, the UAV and all of its components are folded into a shape similar to a cylinder or a rectangle and may be covered by a hard enveloping "capsule" that is loaded into the carrier. The capsule may be shaped as a cylinder or a rectangle or may be shaped according to the UAV's contour. The capsule
15 may be made from light and durable materials (e.g., PVC). The folded UAV is mounted inside the capsule which is loaded into the internal cavity of the carrier. The use of the capsule is intended to minimize environmental factors such as shocks, acceleration and vibration, and allow for smooth release of the UAV from the carrier.

20 It will be appreciated that the folded UAV's shape is not limited to a cylinder or a rectangle.

It will be appreciated that the capsule's shape is not limited to a cylinder or a rectangle.

The carrier is launched to a desired aerial point, using the carrier's own navigational system. According to embodiments of the present invention, while the carrier is in flight,
25 the UAV inside it activates its control and navigational system in order to reduce the awakening period following deployment, and in order to track navigational data prior to deployment. When the carrier reaches the desired aerial point, it may execute vertical maneuvers in order to reduce its speed and create suitable conditions for the release of

the capsule. According to embodiments of the present invention, the order to release the capsule from the carrier is given by the carrier's computer. Alternatively, the order to release the capsule may be given from the UAV to the carrier via communication means between the UAV and the carrier. The order may be given, for example, in a
5 predetermined location, altitude, etc. or by an operator from a distance.

According to embodiments of the present invention, the capsule may be ejected using a pyrotechnic mechanism, pneumatic mechanism, spring(s), etc. installed in the carrier. Following the ejection of the capsule from the carrier, the capsule splits into at least two
10 parts, allowing the UAV to exit into the air. When deployed, the UAV unfolds and immediately activates its engines to avoid loss of altitude and vertical speed.

In a case where the capsule should be ejected using a spring(s), the spring(s) may be loaded when the capsule is inserted into the carrier.

15 In a case where a pyrotechnic mechanism is used to eject the capsule, according to embodiments of the present invention, the capsule may further include a sealing layer (preferably at the rear end of the capsule) in order to create a sealed cavity between the pyrotechnic mechanism and the capsule, thus enabling the pressure created by the pyrotechnic mechanism to eject the capsule.

20 It will be appreciated that other mechanisms may be used for ejecting the capsule and the present invention is not limited to those described above.

Fig. 1 is a schematic view of an exemplary carrier **100** encompassing the UAV's capsule **110** according to embodiments of the present invention.

25 It will be appreciated that the carrier of the present invention is not limited to the carrier shown in **Figs. 1, 2** and **4**.

Fig. 2 is an exploded view of **Fig. 1**.

30 **Fig. 3** is an exploded view of the capsule **110** encompassing the UAV **300**.

For the purpose of explanation and demonstration the UAV hereinafter is presented as a quadcopter or a drone. It will be appreciated that the present invention is not limited to a quadcopter or a drone. According to embodiments of the present invention, the UAV may be any drone having at least two arms, a multi rotor copter, a counter rotor copter
5 or any other aerial vehicle capable of being folded into a capsule.

According to embodiments of the present invention, the capsule **110** may include an inner shape or supports (such as supports **310**) for tightly holding the UAV **300** in order to minimize environmental factors such as shocks, acceleration, vibration, etc.
10

According to embodiments of the present invention, springs may be mounted between the capsule parts for assisting the capsule to split.

Fig. 4 is a schematic view of the UAV's deployment process according to embodiments of the present invention. According to embodiments of the present invention, in order to release the UAV at optimal conditions, when the carrier reaches the deployment destination point, the carrier maneuvers upwards in order to reduce speed and change its angle relative to the ground. The UAV is deployed according to predetermined values of speed and angle. For example, at low speed (substantially zero) and when the carrier
15 is in 70-90 degrees relative to the ground.
20

Figs. 5A and **5B** are schematic top and bottom perspective views of an exemplary UAV **500** according to embodiments of the present invention. The UAV **500** comprises four arms **505A-505D**, each intended to be opened in the direction of the respective arrow **510A-510D**; each arm has an engine controller **515A-515D** for controlling the respective engine **517A-517D** and its propeller **516A-516D**. The UAV **500** further comprises a GPS antenna **520**; a capturing device **530** mounted on a support allowing stable movement of the capturing device (e.g., a camera mounted on a gimbal); at least one battery **540A**; a transceiver **560** and a flight controller (shown in **Fig. 5C**).
25
30

According to embodiments of the present invention, the UAV **500** is surrounded by a frame **580**.

Fig. 5C is a side view of the exemplary UAV **500** (without the frame **580**) showing the transceiver **560**, the flight controller **570**, batteries **540A-540C** (in this exemplary embodiment three are used) where, according to embodiments of the present invention, batteries **540B** and **540C** are fixed and battery **540A** is detachable as will be detailed below. It will be appreciated that battery **540A** may be fixed and batteries **540B** and **540C** may be detachable.

The flight controller of the present invention may be for example, Pixhawk, provided by PX4.

According to embodiments of the present invention, the arms **505A-505D** may be opened by an actuator, by disposable springs or by springs such as springs **550** of **Fig. 5B**. In a case where springs are used, as long as the UAV is in the capsule, the arms are folded under the pressure of the capsule. When the capsule splits and the UAV is released, the springs open the arms. If the springs are disposable springs, they may be discarded as the arms open.

Fig.6 is an enlargement of the front end of the UAV **500** showing springs **550**.

According to embodiments of the present invention, the UAV (**300, 500**) starts its flight at hovering, until the GPS reception signal stabilizes.

Once the GPS signal stabilizes, the UAV begins executing its mission. There are three operational settings: autonomous (for a preloaded mission), real-time remote control, and a combination of the two.

As mentioned above, the UAV (**300, 500**) may include at least one battery. According to embodiments of the present invention, in order to extend the operating time of the UAV (**300, 500**), it may carry several batteries. Once the first battery's capacity is depleted, an additional battery is connected and the first battery may be ejected and discarded. In

such a case, the UAV of the present invention further includes at least one power connection mechanism (equal to the number of the additional batteries) intended to electrically connect the next battery to be used before the depleted battery is discarded and maintain a continuous power supply to the UAV. The connection mechanism may
5 be a mechanical mechanism which physically connects the next battery to be used upon a signal indicating that the currently used battery is about to be depleted; an electrical mechanism which enables an electrical connection of the UAV to the next battery to be used upon a signal indicating that the currently used battery is about to be depleted or any other mechanism capable of ensuring the electrical connection of the
10 UAV to the next battery to be used before discarding the depleted battery.

Fig. 7 is a schematic view of an exemplary detachable battery **700** comprising a physical connector **710**, electric connectors **720A** and **720B** and according to embodiment of the present invention, springs sockets **730** (two are shown). At least one spring (not shown)
15 is intended to be held by the at least one socket **730** (two are shown) and pressed against the UAV body for quick release of the detachable battery **700**. It will be appreciated that the battery **700** is not limited to include the sockets and springs.

A battery release mechanism e.g., a servo motor (not shown) connected to the UAV's body is intended to rotate and release the physical connector **710** (e.g., a screw) upon a
20 signal indicating that the detachable battery should be discarded. When the screw **710** is released the battery **700** is detached and discarded. It will be appreciated that this mechanism may be used for discarding other items such as a package for example. It will be appreciated that more than one or none of the batteries may be detachable batteries. It will be appreciated that other release mechanisms may be used, such as,
25 pyrotechnic mechanisms, mechanical mechanisms, etc.

It is important to maintain the center of gravity of the UAV thus, according to embodiments of the present invention, the detachable battery is located such that the center of gravity will be maintained when the depleted battery is discarded.

According to embodiments of the present invention, in a case where the detachable battery is not located in the center of gravity of the UAV, the UAV may further include at least one weight located such that the center of gravity is maintained thus, when the detachable battery is discarded, the respective weight(s) is discarded as well thus
5 maintaining the center of gravity.

It will be appreciated that the carrier is presented as ejecting the capsule from its front end but the present invention is not limited to carriers that eject the capsule from their front end. According to embodiments of the invention, the capsule may be ejected from the bottom of the carrier, the rear end of the carrier, etc. depending on the carrier's type.

10 It will be appreciated that the UAV of the present invention is not limited to be encapsulated inside the capsule described above. Alternatively, the UAV may be carried (or encompassed) inside the aerial carrier and ejected/released therefrom from the bottom of the carrier, the rear end of the carrier, etc. depending on the carrier's type.

15 It will be appreciated that the carrier of the present invention may carry a plurality of UAVs and release them separately or all together. According to embodiments of the present invention, the carrier may comprise a plurality of release mechanisms, less or as the number of the UAVs.

20 It will be appreciated that the UAV of the present invention may be any drone having at least two arms, a multi rotor copter, a counter rotor copter or any other unmanned aerial vehicle capable of being folded and/or encapsulated and/or carried inside a carrier and/or connected to a carrier.

25 It will be appreciated by persons skilled in the art that the present invention is not limited to what has been particularly shown and described hereinabove. Rather the scope of the present invention is defined by the appended claims and includes combinations and sub-combinations of the various features described hereinabove as well as variations and modifications thereof which would occur to persons skilled in the art upon reading the foregoing description.

CLAIMS

1. A system for launching an Unmanned Aerial Vehicle (UAV), comprising:

a capsule comprising at least two parts;

a UAV configured to be encapsulated inside said capsule in a folded configuration; and

an aerial carrier comprising a release mechanism, said carrier configured to carry said capsule;

said carrier further configured to be launched and eject said capsule upon arrival at a desired aerial location, using said release mechanism;

wherein prior to said ejection, said carrier is further configured to execute vertical maneuvers in order to reduce said carrier's speed and change said carrier's angle thereby creating suitable conditions for said capsule's ejection;

said capsule configured to split and release said UAV upon being ejected; and

said ejected UAV further configured to unfold upon release from said capsule.

2. The system of claim 1, wherein said carrier is selected from the group consisting of glider bombs, rockets, RPV (remote-piloted vehicle), UAVs and mortar shells.

3. The system of claim 1, wherein said capsule is shaped according to said UAV's contour.

4. The system of claim 1, wherein the inner side of said capsule further comprises supports configured to tightly hold said UAV.

5. The system of claim 1, wherein said carrier's speed is substantially zero and said carrier's angle is between 70 to 90 degrees relative to the ground.

6. The system of claim 1, wherein said release mechanism is one of a pneumatic mechanism and at least one spring.

7. The system of claim 1, wherein said release mechanism is a pyrotechnic mechanism; and

wherein said capsule further comprises a sealing layer configured to create a sealed cavity between said pyrotechnic mechanism and said capsule thereby enabling pressure created by said pyrotechnic mechanism to eject said capsule.

8. The system of claim 1, wherein said capsule further comprises springs mounted between said at least two capsule's parts; said springs configured to assist said capsule to split.

9. The system of claim 1, wherein said UAV is a drone comprising at least two arms.

10. The system of claim 9, wherein each arm comprises an engine controller and a propeller.

11. The system of claim 9, wherein each arm comprises at least one spring configured to unfold its respective arm upon release from said capsule.

12. The system of claim 11, wherein said at least one spring is disposable and configured to be discarded upon unfolding of its respective arm.

13. The system of claim 1, wherein said UAV comprises at least one battery; wherein at least one of said at least one battery is a detachable battery.

14. The system of claim 13, wherein said detachable battery comprises a physical connector and electrical connectors; and wherein said UAV further comprises a battery release mechanism and electrical connectors;

said battery's electrical connectors configured to be connected to said UAV's electrical connectors;

said physical connector configured to be connected to said battery release mechanism; and

wherein said battery release mechanism is configured to release said physical connector upon a signal indicating that the detachable battery should be discarded.

15. The system of claim 14, wherein said physical connector is a screw and said battery release mechanism is a servo motor; and

wherein said servo motor is configured to rotate and release said screw.

16. The system of claim 14, wherein said battery further comprises at least one socket configured to press at least one spring against said UAV; said at least one spring is configured to assist in releasing of said battery.

17. The system of claim 14, wherein said battery release mechanism is one of a pyrotechnic mechanism and a mechanical mechanism.

18. A method of launching an Unmanned Aerial Vehicle (UAV), comprising:

launching an aerial carrier comprising a capsule and a release mechanism;

said capsule comprises at least two parts and configured to encapsulate a UAV in a folded configuration;

executing, by said carrier, vertical maneuvers in order to reduce said carrier's speed and change said carrier's angle thereby creating suitable conditions for ejecting said capsule;

ejecting said capsule upon arrival at a desired aerial location, using said release mechanism;

splitting said capsule and releasing said UAV upon said ejecting; and

unfolding said folded UAV upon said releasing.

19. The method of claim 18, wherein said carrier is selected from the group consisting of glider bombs, rockets, RPV (remote-piloted vehicle), UAVs and mortar shells.

20. The method of claim 18, wherein said capsule is shaped according to said UAV's contour.

21. The method of claim 18, wherein the inner side of said capsule further comprises supports configured to tightly hold said UAV.
22. The method of claim 18, wherein said carrier's speed is substantially zero and said carrier's angle is between 70 to 90 degrees relative to the ground.
- 5 23. The method of claim 18, wherein said release mechanism is one of a pneumatic mechanism and at least one spring.
24. The method of claim 18, wherein said release mechanism is a pyrotechnic mechanism; and
- 10 wherein said capsule further comprises a sealing layer configured to create a sealed cavity between said pyrotechnic mechanism and said capsule thereby enabling pressure created by said pyrotechnic mechanism to eject said capsule.
25. The method of claim 18, wherein said capsule further comprises springs mounted between said at least two capsule's parts; said springs configured to assist said capsule to split.
- 15 26. The method of claim 18, wherein said UAV is a drone comprising at least two arms.
27. The method of claim 26, wherein each arm comprises an engine controller and a propeller.
28. The method of claim 26, wherein each arm comprises at least one spring and
- 20 wherein said unfolding comprises using said at least one spring for unfolding the respective arm upon said releasing from said capsule.
29. The method of claim 28, wherein said at least one spring is disposable and the method further comprises discarding said at least one spring upon unfolding of its respective arm.
- 25 30. The method of claim 18, wherein said UAV comprises at least one battery; wherein at least one of said at least one battery is a detachable battery.
31. The method of claim 30, wherein said detachable battery comprises a physical connector and electrical connectors; and wherein said UAV further comprises a battery release mechanism and electrical connectors;

said battery's electrical connectors are connected to said UAV's electrical connectors;

said physical connector is connected to said battery release mechanism; and

5 wherein said method further comprises releasing, by said battery release mechanism, said physical connector upon a signal indicating that the detachable battery should be discarded.

32. The method of claim 31, wherein said physical connector is a screw and said battery release mechanism is a servo motor; and

10 wherein said releasing comprises rotating said servo motor and releasing said screw.

33. The method of claim 31, wherein said battery further comprises at least one socket configured to press at least one spring against said UAV;

said method further comprises assisting, by said at least one spring, in the releasing of said battery.

15 34. The method of claim 31, wherein said battery release mechanism is one of a pyrotechnic mechanism and a mechanical mechanism.

35. A system for launching an Unmanned Aerial Vehicle (UAV), comprising:

an aerial carrier comprising a release mechanism, said carrier configured to carry a UAV in a folded configuration;

20 said carrier further configured to be launched and eject said folded UAV upon arrival at a desired aerial location, using said release mechanism;

wherein prior to said ejection, said carrier is further configured to execute vertical maneuvers in order to reduce said carrier's speed and change said carrier's angle thereby creating suitable conditions for said UAV's ejection; and

said ejected UAV further configured to unfold upon release from said carrier.

36. The system of claim 35, wherein said carrier is selected from the group consisting of glider bombs, rockets, RPV (remote-piloted vehicle), UAVs and mortar shells.
37. The system of claim 35, wherein said carrier's speed is substantially zero and said carrier's angle is between 70 to 90 degrees relative to the ground.
38. The system of claim 35, wherein said release mechanism is one of a pneumatic mechanism and at least one spring.
39. The system of claim 35, wherein said UAV is a drone comprising at least two arms.
40. The system of claim 39, wherein each arm comprises an engine controller and a propeller.
41. The system of claim 39, wherein each arm comprises at least one spring configured to unfold its respective arm upon release from said carrier.
42. The system of claim 41, wherein said at least one spring is disposable and configured to be discarded upon unfolding of its respective arm.
43. The system of claim 35, wherein said UAV comprises at least one battery; wherein at least one of said at least one battery is a detachable battery.
44. The system of claim 43, wherein said detachable battery comprises a physical connector and electrical connectors; and wherein said UAV further comprises a battery release mechanism and electrical connectors;
- said battery's electrical connectors configured to be connected to said UAV's electrical connectors;
- said physical connector configured to be connected to said battery release mechanism; and

wherein said battery release mechanism is configured to release said physical connector upon a signal indicating that the detachable battery should be discarded.

5 45. The system of claim 44, wherein said physical connector is a screw and said battery release mechanism is a servo motor; and

wherein said servo motor is configured to rotate and release said screw.

46. The system of claim 44, wherein said battery further comprises at least one socket configured to press at least one spring against said UAV; said at least one spring is configured to assist in releasing of said battery.

10 47. The system of claim 44, wherein said battery release mechanism is one of a pyrotechnic mechanism and a mechanical mechanism.

1/8

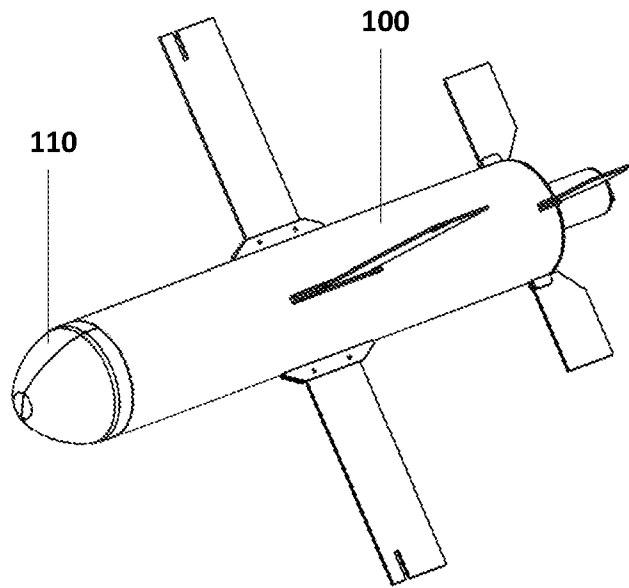

Fig. 1

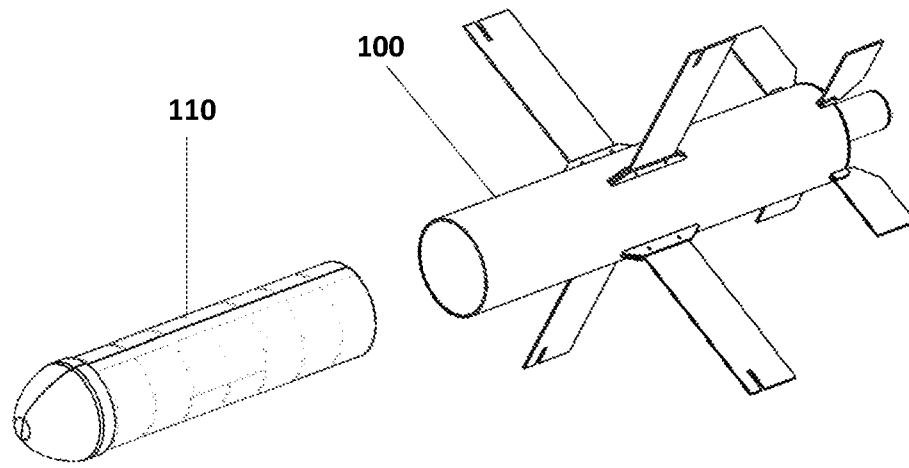

Fig. 2

3/8

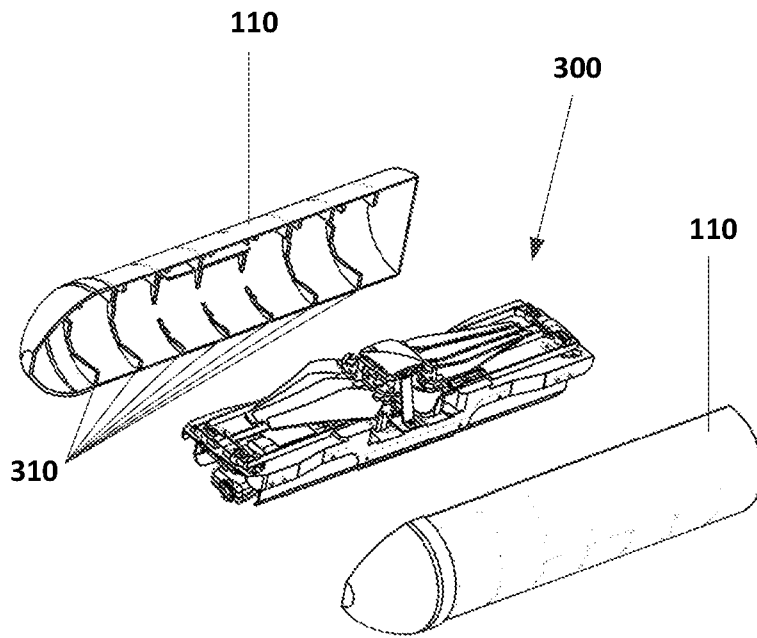

Fig. 3

4/8

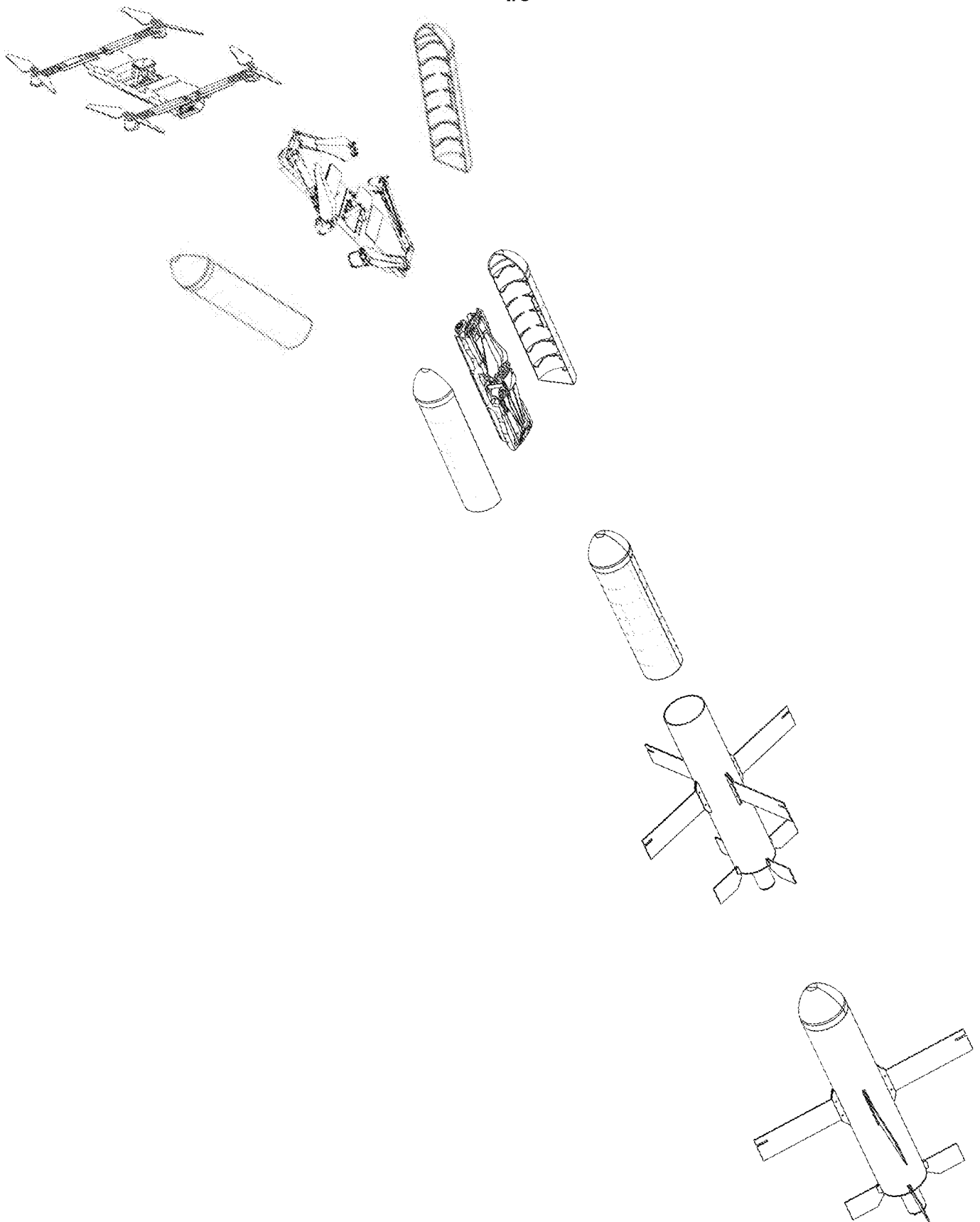

Fig. 4

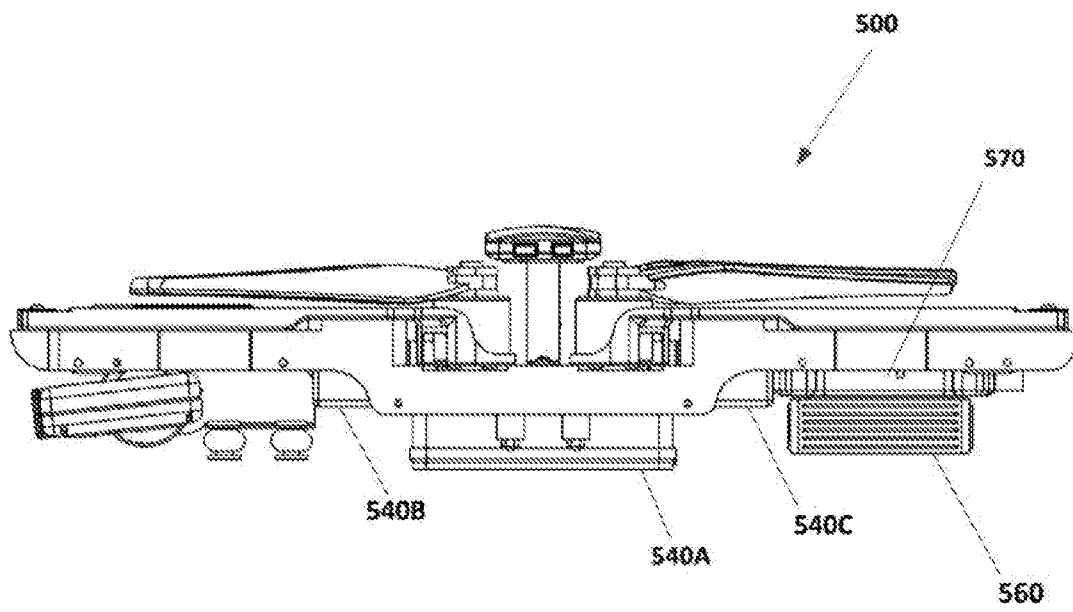

Fig. 5C

7/8

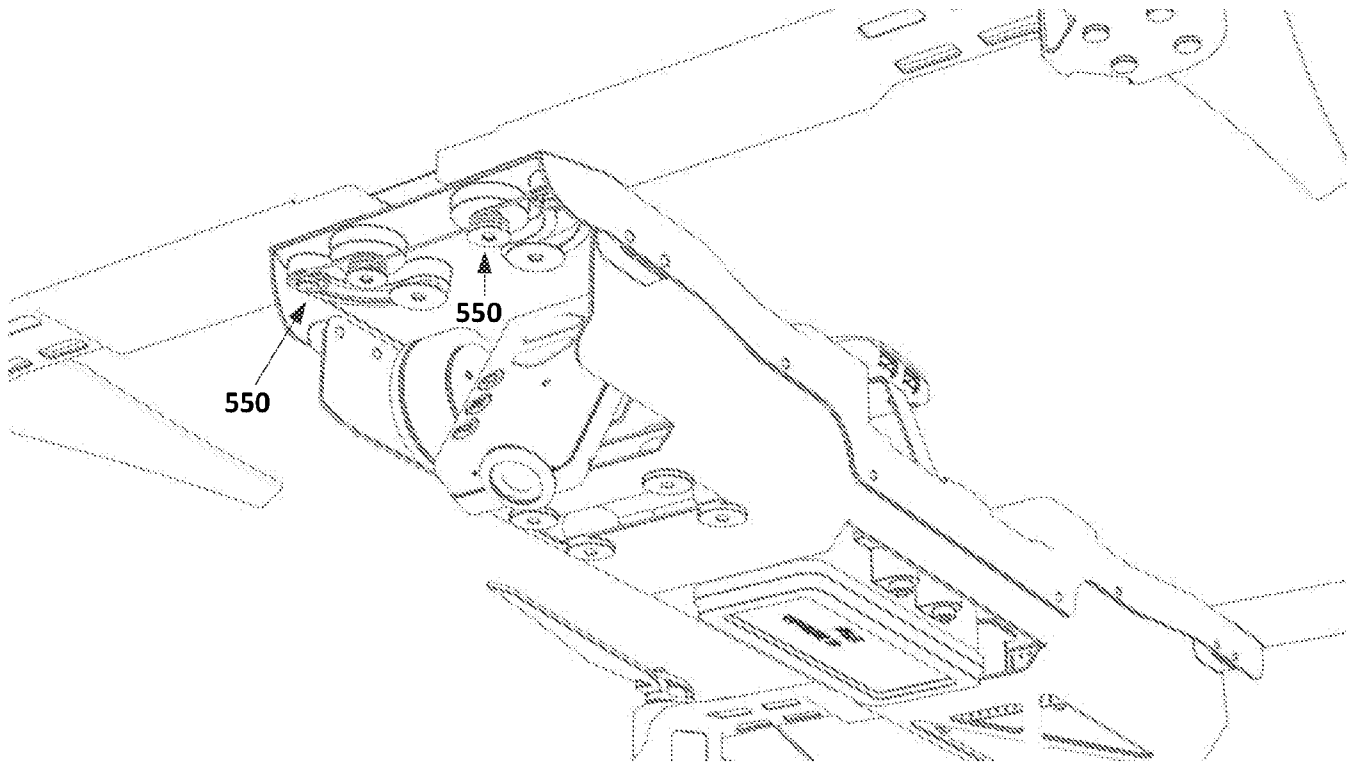

Fig. 6

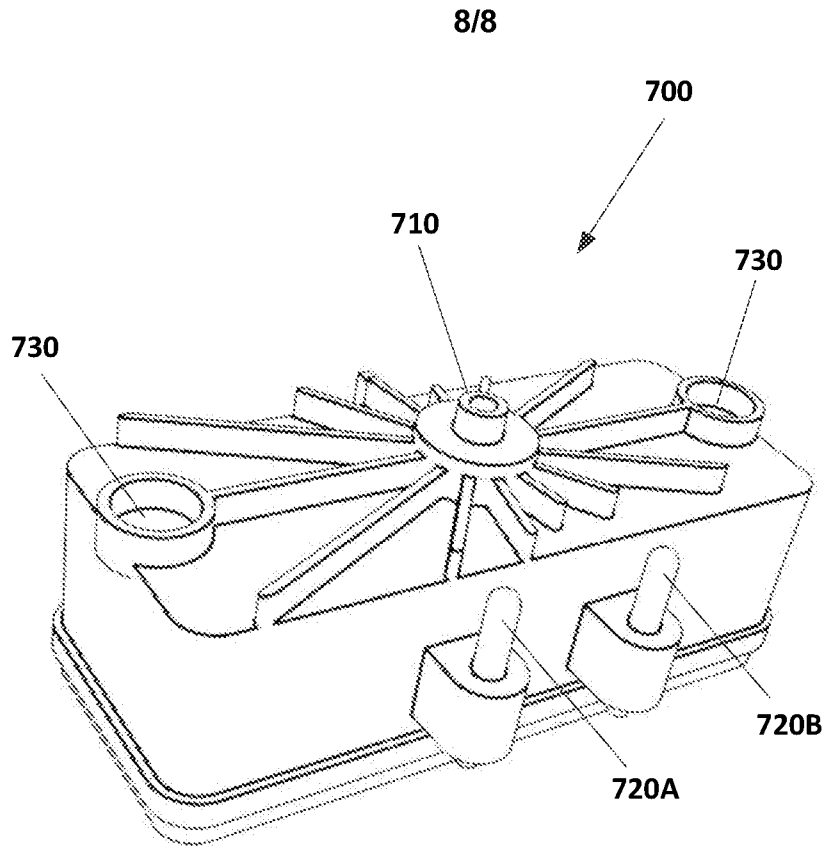

Fig. 7

INTERNATIONAL SEARCH REPORT

International application No.

PCT/IL2018/050614

A. CLASSIFICATION OF SUBJECT MATTER IPC (2018.01) B64C 39/00, B64C 35/02, B64D 1/12		
According to International Patent Classification (IPC) or to both national classification and IPC		
B. FIELDS SEARCHED		
Minimum documentation searched (classification system followed by classification symbols) IPC (2018.01) B64C 39/00, B64C 35/02, B64D 1/12		
Documentation searched other than minimum documentation to the extent that such documents are included in the fields searched		
Electronic data base consulted during the international search (name of data base and, where practicable, search terms used) Databases consulted: Esp@cenet, Google Patents, PatBase, Orbit		
C. DOCUMENTS CONSIDERED TO BE RELEVANT		
Category*	Citation of document, with indication, where appropriate, of the relevant passages	Relevant to claim No.
X	US 2015266578 A ELKINS 24 Sep 2015 (2015/09/24) whole	35-39
Y	whole	1-13,18-30,40-43
A	whole	14-17,31-34,44-47
Y	US 2017057635 A STRAYER 02 Mar 2017 (2017/03/02) whole	1-30,40-43
A	whole	14-17,31-34,44-47
A	US 20160347476 A ANDRYUOKOV 01 Dec 2016 (2016/12/01) whole	1-44
<input type="checkbox"/> Further documents are listed in the continuation of Box C. <input checked="" type="checkbox"/> See patent family annex.		
* Special categories of cited documents: "A" document defining the general state of the art which is not considered to be of particular relevance "E" earlier application or patent but published on or after the international filing date "L" document which may throw doubts on priority claim(s) or which is cited to establish the publication date of another citation or other special reason (as specified) "O" document referring to an oral disclosure, use, exhibition or other means "P" document published prior to the international filing date but later than the priority date claimed "T" later document published after the international filing date or priority date and not in conflict with the application but cited to understand the principle or theory underlying the invention "X" document of particular relevance; the claimed invention cannot be considered novel or cannot be considered to involve an inventive step when the document is taken alone "Y" document of particular relevance; the claimed invention cannot be considered to involve an inventive step when the document is combined with one or more other such documents, such combination being obvious to a person skilled in the art "&" document member of the same patent family		
Date of the actual completion of the international search 02 Sep 2018		Date of mailing of the international search report 03 Sep 2018
Name and mailing address of the ISA: Israel Patent Office Technology Park, Bldg.5, Malcha, Jerusalem, 9695101, Israel Facsimile No. 972-2-5651616		Authorized officer GUTKIN Solomon Telephone No. 972-2-5651763

INTERNATIONAL SEARCH REPORT
Information on patent family members

International application No.
PCT/IL2018/050614

Patent document cited search report	Publication date	Patent family member(s)	Publication Date
US 2015266578 A	24 Sep 2015	NONE	
US 2017057635 A	02 Mar 2017	NONE	
US 20160347476 A	01 Dec 2016	NONE	