

F. A. CURTIS.  
LAMP.  
APPLICATION FILED AUG. 6, 1908.

917,262.

Patented Apr. 6, 1909.

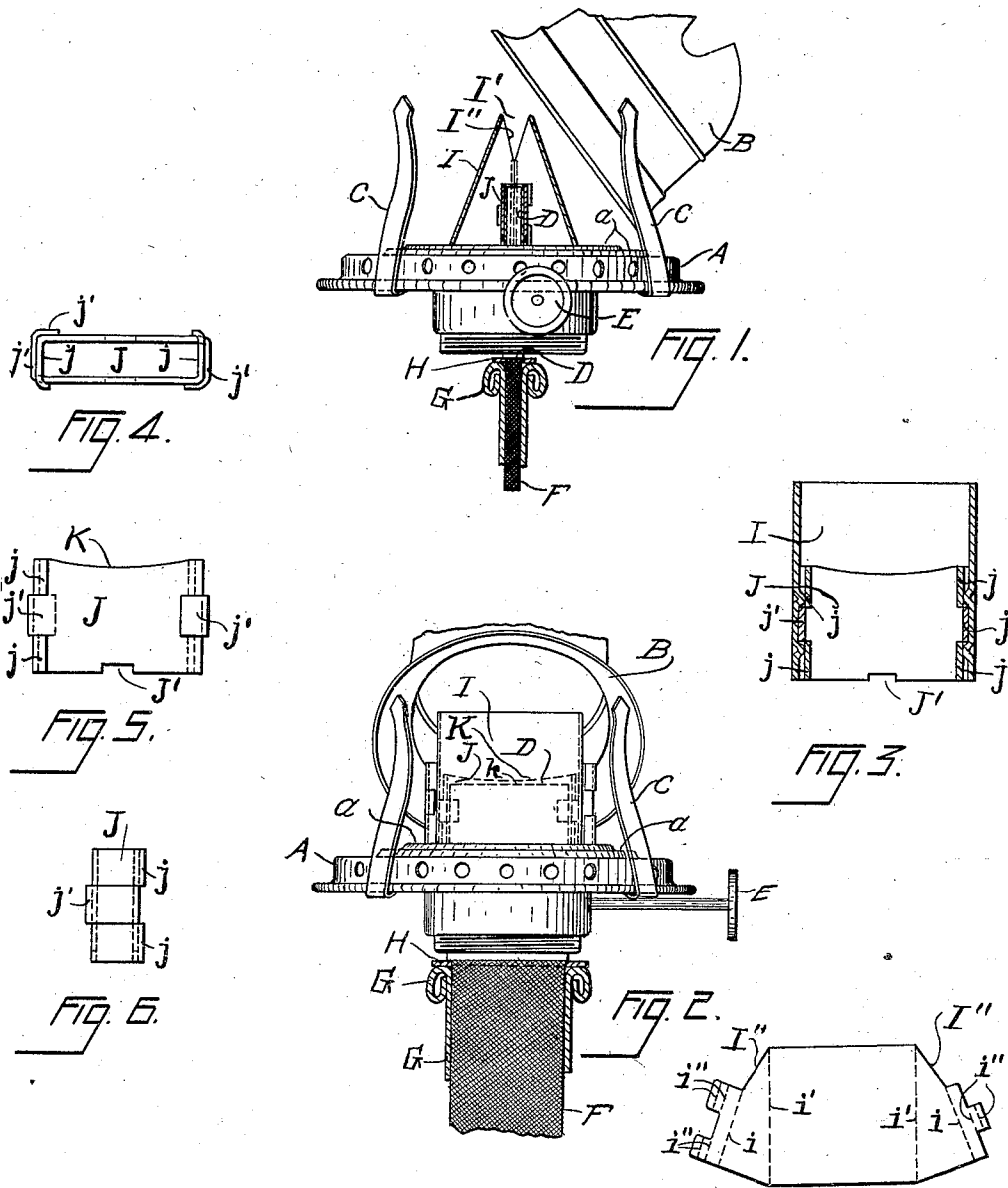

WITNESSES:  
*D. Owen*  
*E. N. Bowles*

INVENTOR  
*Frederic A. Curtis;*  
By *Charles Sumner Brown,*  
ATTORNEY

# UNITED STATES PATENT OFFICE.

FREDERIC A. CURTIS, OF CHICAGO, ILLINOIS, ASSIGNOR TO STANDARD WICK AND BURNER CO., OF CHICAGO, ILLINOIS, A CORPORATION.

## LAMP.

No. 917,262.

Specification of Letters Patent.

Patented April 6, 1909.

Application filed August 6, 1908. Serial No. 447,236.

*To all whom it may concern:*

Be it known that I, FREDERIC A. CURTIS, a citizen of the United States, and a resident of Chicago, in the county of Cook and State of Illinois, have invented certain new and useful Improvements in Lamps, of which the following, when taken in connection with the drawing accompanying and forming a part hereof, is a full and complete description, sufficient to enable those skilled in the art to which it pertains to understand, make, and use the same.

This invention relates to kerosene lamps using chimneys; and the principal objects of the invention are to obtain a lamp by means of which a large flame and one of great candle power may be produced, reference being had to the size of the wick employed.

A further object of the invention is to obtain a lamp the burner whereof is simple in construction, easily cleaned, readily trimmed, and not liable to get out of order.

A further object of the invention is to obtain a lamp the burner whereof is durable, uniform in operation, and economical in construction.

Other objects sought by me are disclosed in this description.

In the drawing referred to, Figure 1 is a side elevation of a lamp, with the chimney and oil receptacle removed, embodying the invention, with the dome of the burner turned back to expose the parts thereunder, which are shown in vertical section, to view.

Fig. 2 is a front elevation of the parts illustrated in Fig. 1, with the dome turned back. Fig. 3 is a vertical sectional view of the wick tube guard, and air deflector, which form essential elements in a device embodying the invention. Fig. 4 is a top plan view of the wick tube guard of the device. Fig. 5 is a side elevation of a wick tube guard.

Fig. 6 is an end elevation of a wick tube guard. Fig. 7 is a plan view of a blank from which the wick tube guard is obtained; and Fig. 8 is a plan view of a blank from which the air deflector of the device is obtained.

A reference letter applied to designate a

given part is used to indicate such part 50 throughout the several figures of the drawing, wherever the same appears.

A is the base of the burner of the device, and *a* is a foraminated table to base A.

B is a dome, and C, C, are springs by means 55 of which a chimney is held in position on the burner.

D is a wick tube.

E is a wick raising thumb wheel.

F is an ordinary flat lamp wick. G, 60 (shown in vertical section in Figs. 1 and 2), is an additional lamp wick, of the kind known as round lamp wicks. Wick F is drawn through wick G.

H is a washer on wick F, to prevent wick 65 G, or any part thereof, from being drawn into the wick tube D when wick F is raised by the turning of the thumb wheel E.

I is an air deflector which is placed on the foraminated table *a* so that some of the air 70 which flows up through the foraminations in such table will be thereby deflected into the flame from the wick F, or into the vapor or gas from which the flame is obtained. Air deflector I is illustrated as made from a 75 blank cut out of sheet metal, (see Fig. 8), and is obtained by taking two of such blanks and bending them up on lines *i*, *i'*, and *i''* to shape them and to join them together. Air deflector I is provided with aperture I' 80 for the passage of gas or vapor and air to the flame of the lamp; and the blank is cut away on line I'' to obtain a V shaped aperture at the ends of the air deflector.

J is a guard interposed between the wick 85 tube D, (to which it fits reasonably close) and the air deflector I. Guard J may be made from the blank illustrated in Fig. 7, and of sheet metal.

*j*, *j*, *j'*, are ears on the blank illustrated in 90 Fig. 7; and to obtain such guard it is simply necessary to take two of the blanks and bend up the ears so that the ear *j'* on one blank will come between the ears *j*, *j*, on the other blank; and also to bend such ears so as to 95 come a short distance along the sides of the guard. When such ears are thus bent the ears *j'* extend outside of ears *j*, *j*, at the ends

of the guard, and the guard, when thus made, is of the right length to come into close contact with the ends of the air deflector I. The ends of deflector I are indented, both above and below the ears  $j'$ , to hold the guard and the deflector closely and firmly together, as one piece. When thus made the heat of the deflector I will be conveyed by conduction to the guard J.

$j''$ ,  $j''$  are broken lines indicating the lines on which the blanks (illustrated in Fig. 8), are bent up to obtain the wick tube guard J.

$J'$  is a recess in the blank which is made to provide a passage through which vapor or gas from the oil receptacle may flow.

K is the top edge of the wick tube guard J.  $k$  is the top edge of the wick tube D. The edge K is above the edge  $k$ , and such edge K is cut away to make the upper end thereof concave. By this means a small generating chamber is obtained adjacent to the wick F, and more of the wick is exposed midway between the edges thereof than is exposed at such edges.

Some of the functions of the additional wick are, to supply oil to wick F, at the upper end of such wick, in larger quantity than can be supplied by a single flat wick; particularly after a portion of the oil in the receptacle has been used. And to permit the use of a short wick F.

Some of the functions of the air deflector I and guard J are;—to deflect air into the vapor or gas which is about to be consumed at a determined point below the aperture in the dome; to convey by conduction heat from the air deflector to the guard and from the guard to the wick tube; to obtain a gas generating chamber between the wick and the guard, above the wick tube and adjacent to the wick; to maintain a determined relation between the air deflector and the wick tube guard; and to provide means to hold both devices in place on the wick tube, by friction.

In constructing a lamp with the air deflector and the wick tube guard arranged to form elements thereof, the wick tube is not made as long above the table  $a$  as wick tubes are generally made, and hence, where a burner is to be made over, or made to form a part of a device embodying this invention, among other things to be done the wick tube is cut off. In a one inch wick tube there may be as much as three eighths of an inch cut off the upper end of such tube. By cutting the top of the wick tube guard away as shown, that is, concave on the upper end thereof, a considerably greater area of the wick is exposed near the middle thereof than is exposed at the edges, and greater body is thereby given to the flame of the lamp. By arranging the air deflector and wick tube guard as described kerosene supplied to the

flame is heated and vaporized and oxygen in sufficient quantity to support combustion is supplied.

To trim the wick the air deflector and the wick tube guard may be removed and the wick trimmed squarely across, near to the upper end of the wick tube (D), and the air deflector and guard then replaced by sliding the guard over the wick tube. The guard fits to the wick tube so closely that it is maintained in place by friction, and the heat thereof is conveyed to the tube by conduction. By arranging the wick tube lower than the guard, at the upper ends thereof, and obtaining the generating chamber hereinbefore referred to between the wick and the guard, the vapor or gas presented to the flame of the burner is in a highly heated condition; and the combined action of such chamber and of the air deflector and guard produces a flame of considerable size having a depth in the central portion thereof which produces a good light, not easily made to flicker or tremble.

Having thus described my invention, the construction of a device embodying the same, and the operation thereof, what I claim as new and desire to secure by Letters Patent is:—

1. The combination of a base provided with a foraminated table, a dome on the base, such dome provided with an aperture for the flame of the device, and arranged to form an air deflector, an additional air deflector provided with an aperture for the flame, and a wick tube guard, a wick tube, such additional air deflector and guard joined together and removably attached to the tube, and such dome and air deflector arranged to respectively direct into the flame of the device the air which flows through the foraminated table thereunder, substantially as described.

2. The combination of a dome arranged to form an air deflector an additional air deflector under the dome, and a wick tube guard, such additional air deflector and the guard arranged to come into close contact at the ends thereof, and means to hold them in determined relative position; substantially as described.

3. A wick tube guard comprising duplicate pieces of sheet metal bent up and joined together, in combination with a dome arranged to form an air deflector, an additional air deflector and a wick tube provided with a concave upper edge, such guard arranged to fit closely to the tube, with the upper end of the guard made concave and above the upper end of the tube, and to fit closely at the ends thereof to the additional air deflector, substantially as described.

4. The combination of a wick tube guard, a wick tube and a dome, arranged to form an

air deflector, an additional air deflector, such guard provided with a concave upper edge and arranged to slide over the tube and to come in close contact therewith, with the upper edge of the guard above the upper edge of the tube, and the guard arranged so that the ends thereof come in close contact with the ends of the additional air deflector, and such guard and additional air deflector joined together in a determined relation; substantially as described.

FREDERIC A. CURTIS.

In the presence of—

ERNEST W. BOWLES,  
CHARLES TURNER BROWN.