

I. L. ROBBLEE.
FUNNEL.

APPLICATION FILED MAY 10, 1911. RENEWED MAR. 28, 1913.

1,069,579.

Patented Aug. 5, 1913.

2 SHEETS—SHEET 1.

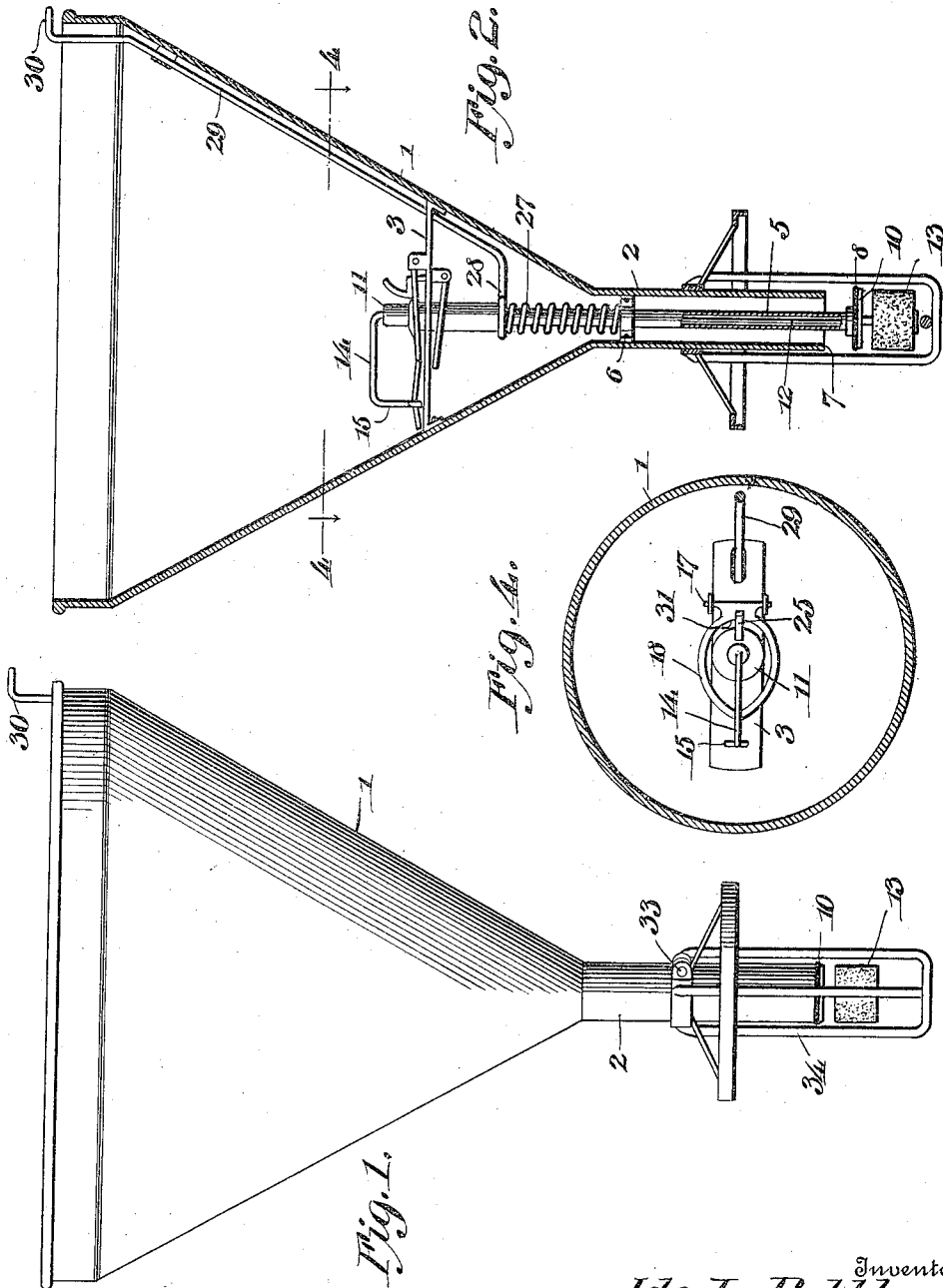

Witnesses
V. D. Palm
James D. ...

Inventor
Ide L. Robblee.

By *Victor J. Evans.*
 Attorney

I. L. ROBBLEE.
FUNNEL.

APPLICATION FILED MAY 10, 1911. RENEWED MAR. 28, 1913.

1,069,579.

Patented Aug. 5, 1913.

2 SHEETS—SHEET 2.

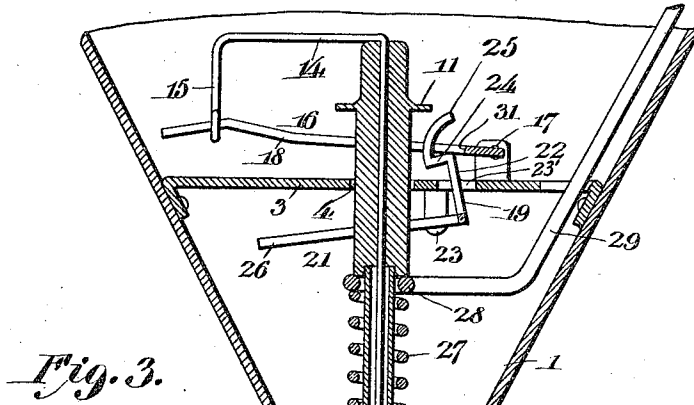

Fig. 3.

Fig. 6.

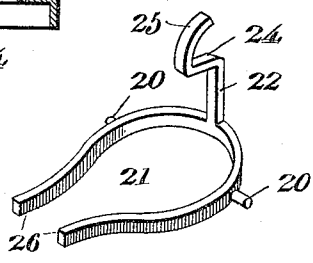
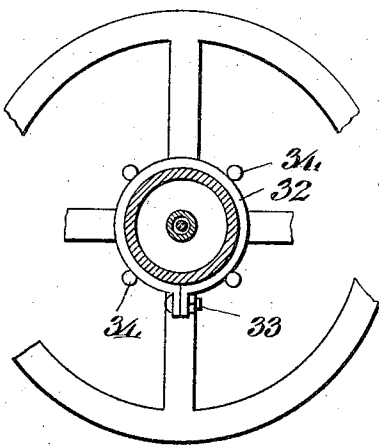

Fig. 5.

Witnesses

A. D. Smith
James D. Jones

Inventor

Ide I. Robblee.

By *Victor J. Evans*

Attorney

UNITED STATES PATENT OFFICE.

IDE L. ROBBLEE, OF SPRINGFIELD, MASSACHUSETTS.

FUNNEL.

1,069,579.

Specification of Letters Patent.

Patented Aug. 5, 1913.

Application filed May 10, 1911, Serial No. 626,212. Renewed March 28, 1913. Serial No. 757,481.

To all whom it may concern:

Be it known that I, IDE L. ROBBLEE, a subject of the King of Great Britain, residing at Springfield, in the county of Hampden and State of Massachusetts, have invented new and useful Improvements in Funnel, of which the following is a specification.

This invention relates to funnels, and has for an object to provide means whereby the liquid when the funnel is used for filling a vessel will be automatically cut off so as to avoid loss of the liquid when the receptacle is filled to its capacity.

Another object of the invention is to provide float controlled mechanism for operating the cut off, the said mechanism being mounted on the funnel so that it may be made to respond under action of the liquid on its predetermined rise in the receptacle.

In the drawings, forming a portion of this specification and in which like numerals of reference indicate similar parts in the several views:—Figure 1 is a side view of the funnel. Fig. 2 is a vertical section therethrough showing the float and the valve in their lowered positions. Fig. 3 is a similar view showing the float and the valve in their elevated positions. Fig. 4 is a horizontal section taken on line 4—4 of Fig. 2. Fig. 5 is a perspective view of the latch member. Fig. 6 is a horizontal section on line 6—6 of Fig. 3.

The funnel 1 is provided at its small end or apex with a nozzle 2 which is of the same transverse diameter throughout. Above the nozzle and suitably secured in the funnel is a guide bracket 3 in which is formed an opening 4 which is arranged in axial alignment with the nozzle and through which extends the sliding valve rod 5. This rod is also slidably mounted in a bracket 6 which extends across the nozzle and which is suitably secured thereto. The lower end of the nozzle is provided with a valve seat 7 against which the valve 8 is adapted to bear as will be hereinafter described. The lower end of the valve rod is preferably provided with a shoulder 9 and beneath the shoulder the rod is threaded to adjustably receive the washer-clamping disk 10 which is adapted to bear against the washer so as to hold the

same positioned upon the valve rod 5. The upper end of the valve rod has thereon a disk 11, the same being disposed above the guide bracket 3. The valve rod is hollow and extended therethrough is a rod 12, the lower end of the rod being disposed below the valve 8 and having mounted thereon a float 13 which is preferably constructed of cork or the like.

The valve-closing rod has its upper end provided with a horizontal arm 14 and a vertical eye portion 15. A keeper member 16 embraces the valve rod disk 11, and as illustrated, said keeper is pivoted, at 17, on the guide bracket 3. An arm 18 extends horizontally from the keeper and is slidable in the eye portion 15 of the arm 14. A gravitating latch 19 is provided with pintles 20 which are pivoted in depending ears 23 on the guide bracket 3. The latch member is provided with a substantially yoke portion 21 which embraces the valve rod. At the bite of the yoke the latch is provided with a vertical tongue 22 which extends through the slot 23' in the guide bracket 3. The upper end of the tongue is provided with an integral retaining nose 24. This nose is adapted to be extended over the disk 11 on the valve rod so as to engage the same to hold the valve normally in an open position during the filling operation. The nose 24 is provided with a deflecting or guiding surface 25 which is adapted to be disposed in the path of the downward movement of the disk 11 on movement of the valve rod to its closed position so as to cause a positive engagement of the nose 24 with the disk. As stated, the latch member 19 is adapted to gravitate to a position where the surface 25 thereof will be disposed in the path of the downward movement of the disk 11 and to insure this action on operation of the latch, I preferably provide the yoke portion 21 thereof with a pair of suitably spaced arms 26 to increase the weight of the latch at one side of its point of pivotal connection with the guide bracket 3.

A restoring spring 27 encircles the valve rod, one end of the spring being engaged against the guide bracket 6 in the nozzle of the funnel and the other end of the spring being engaged against the shoulder 28 on

the valve rod, the spring obviously exerting its tension to hold the valve rod against the action of the latch member hereinbefore described. A sliding manually operated rod 5 29 is mounted interiorly of the funnel, the lower end thereof being suitably connected with the valve rod so that the same may be moved against the tension of the spring 27. The upper end of the rod 29 is provided with a knob-forming portion 30 which may 10 be pressed downwardly by the hand when it is desired to open the valve 8. When the valve 8 is in its open position the portion 31 of the latch keeper 16 will be engaged behind the vertical tongue 22 of the latch member so as to hold the said member effectively in its set position. A clamping collar 32 embraces the nozzle 2 of the funnel, being adjustable vertically on the nozzle 20 and having thereon a retaining or clamping device 33 so as to hold the collar against sliding movement. This collar is provided with a depending float cage 34 in which the float and the valve are slidably mounted. 25 The collar 32 may be adjusted on the nozzle at the will of the operator so that the valve will respond to the action of the fluid on the rise of the latter in the receptacle, the adjustability of the collar of course serving as means whereby the adjustment of the nozzle into the receptacle can be readily determined. In this way the valve will respond to predetermined levels of the liquid. The float cage 34 is adapted to serve as a guard or protector for the nozzle and float 35 when the device is not in use.

In operation of the device, the nozzle of the funnel is inserted into the filling opening of the receptacle, after which the rod 40 29 is actuated so as to move the valve 8 to its open position. As previously described, the valve will be held open under the action of the latch member 19. On the rise of the liquid in the receptacle to a predetermined height the float will be engaged by the liquid and moved thereby in an upward direction. This causes the rocking movement to be imparted to the keeper 16 so as to release the latter from the latch member. Under the action of the spring 27 the valve 50 will then be automatically moved to its cut-off or closed position which will positively prevent the further flow of the liquid from the funnel.

55 I claim:

1. A funnel, a valve rod movable therein, a valve carried by the rod, a spring engaging the rod and adapted to normally hold the valve in a closed position, a guide for the said rod, a float located below the valve and supported by a rod extending through the said valve rod and terminating to provide an eye, a disk formed integral with the said rod, a latch member adapted to engage

the said disk to hold the said valve in an open position, and a keeper pivoted to the said guide and adapted to engage the said latch and having its free end slidably mounted in the eye of the said float supporting rod substantially as and for the purpose described. 65 70

2. A funnel, a valve rod, movable therein, a valve carried by the rod, a spring engaging the rod to normally hold the valve in a closed position, a disk formed integrally 75 with the said rod, a gravitating latch member disposed in the path of movement of the said disk and adapted to engage the same on downward movement of the said rod to hold the said valve in open position against the 80 tension of the spring, a keeper adapted to engage the said latch member, and means for releasing the said latch and operatively connected with the said keeper.

3. A funnel, a valve rod movable therein, 85 a valve carried by the rod, a disk formed integral with the rod, a spring engaging the rod, a guide member, a gravitating latch member, comprising a yoke portion and a vertically disposed latch arm, said yoke portion embracing the said rod and arranged below the said guide and adapted normally to hold the said arm disposed in the path of 90 movement of the said disk, said arm being adapted to engage the disk to hold the said valve in an open position, a keeper pivoted above the said guide and to engage the said arm in one position thereof, and means for releasing the said latch member and operatively connected to the said keeper. 100

4. A funnel having a discharge nozzle, a valve rod movable therein, a valve carried by the rod, a bracket arranged in the nozzle adjacent the upper end thereof, the said rod being provided with a shoulder, a spring 105 embracing the rod and bearing against the said bracket and shoulder respectively and exerting its tension to normally hold the valve in a closed position, a disk formed integral with the rod and disposed above 110 the said shoulder, a latch member adapted to engage the said disk to hold the valve in an open position against the tension of the spring, a keeper adapted to operatively engage the said latch, and means for releasing 115 the latch and connected to the said keeper.

5. A funnel, a valve rod movable there-through, a float located beneath the nozzle of the funnel, a rod supporting the float and extending through the valve rod, a valve 120 carried by the valve rod and disposed above the float, a spring engaging the valve rod and exerting its tension thereagainst to hold the valve normally in a closed position, a disk supported by the valve rod, a latch member located interiorly of the funnel and adapted to engage the disk to hold the rod against the tension of the said spring, a 125

keeper engaging the latch member to hold
the same in its engaged position with the
disk, and cooperating relatively movable
elements on the keeper and float rod re-
spectively, operating to move the keeper to
5 a released position on movement of the float
to elevated position.

In testimony whereof I affix my signature
in presence of two witnesses.

IDE L. ROBBLEE.

Witnesses:

WYMAN C. PARKER,
H. E. ROBBINS.

Copies of this patent may be obtained for five cents each, by addressing the "Commissioner of Patents,
Washington, D. C."