

T. S. Brown. Ship's Berth.

N^o 29,763.

Patented Aug. 28, 1860.

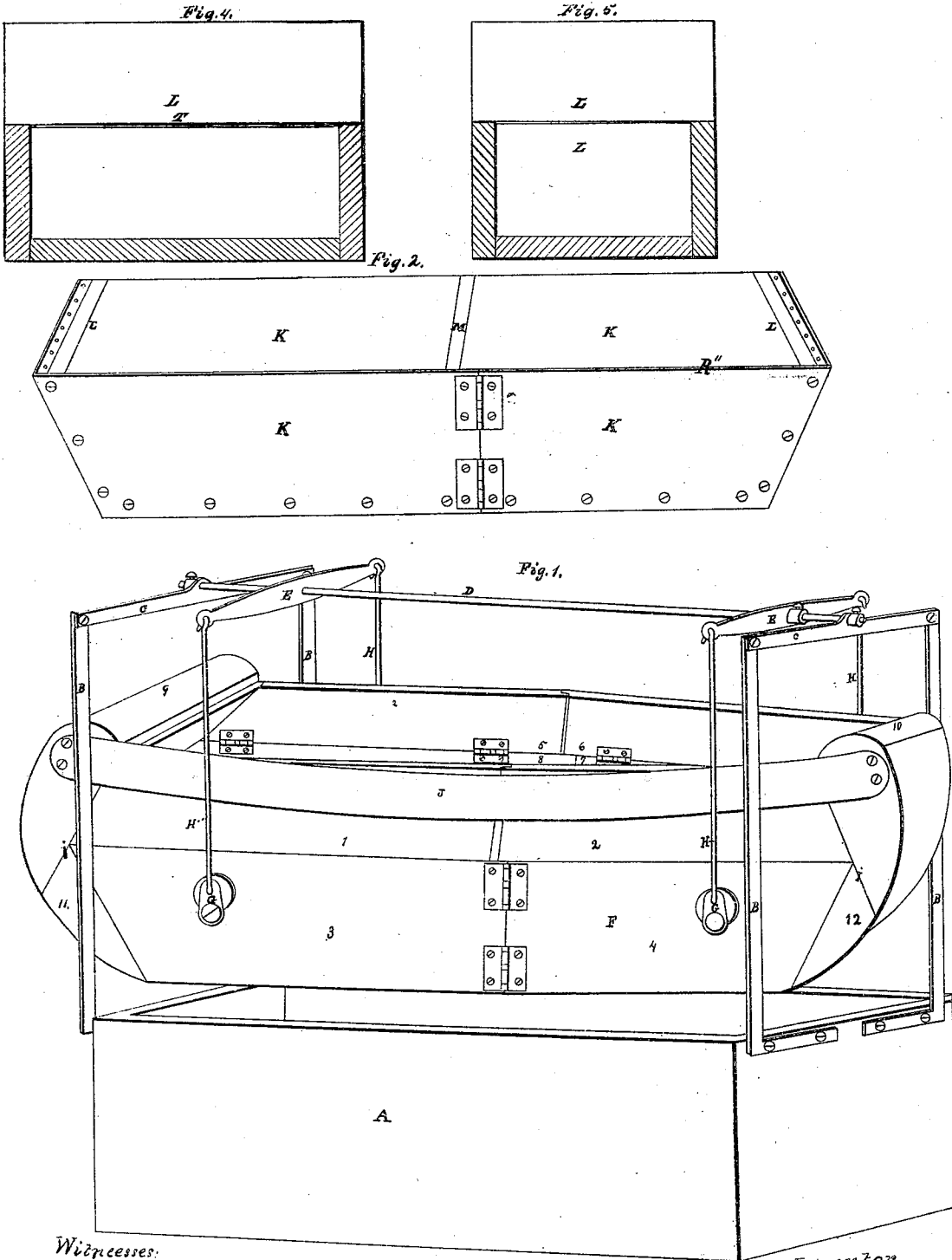

Witnesses:
Harold Schuch
Jens matorson

Inventor:
Thomas S. Brown

T. S. Brown. Ship's Berth.

N^o 29,763.

Patented Aug 28, 1860.

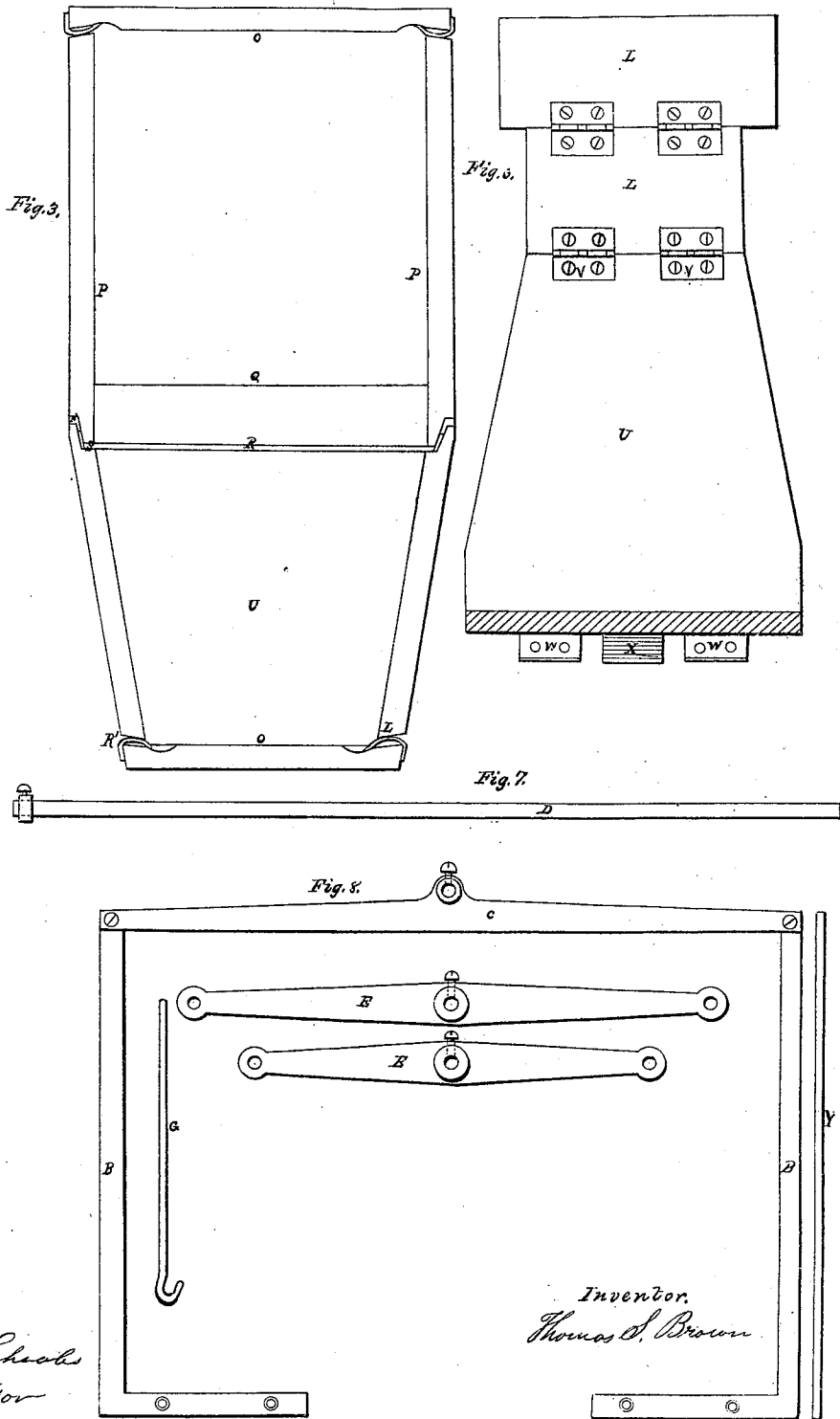

Witnesses:
Marcus Schickel
First Master

Inventor.
Thomas S. Brown

UNITED STATES PATENT OFFICE.

THOMAS S. BROWN, OF PHILADELPHIA, PENNSYLVANIA.

OSCILLATING SHIP'S BERTH.

Specification of Letters Patent No. 29,763, dated August 28, 1860.

To all whom it may concern:

Be it known that I, THOMAS S. BROWN, of the city and county of Philadelphia and State of Pennsylvania, have invented a new and useful Improvement in Marine Sleeping-Berths; and I do hereby declare that the following is a full, clear, and exact description of the same, reference being had to the accompanying drawings, forming a part of this specification, in which—

Figure 1 represents a perspective view of the combined suspended berth and life boat; Fig. 2, a side view, and Fig. 3, a top view of the upper part of the boat; Figs. 4 and 5, front and end views of the boat; Figs. 6, 7, and 8, views of detached portions of the apparatus.

Similar characters of reference in each of the several figures indicate corresponding parts.

The nature of my invention consists, 1st, in the arrangement of a rock shaft, cross bars and suspension rods, in combination with a berth for the purpose of neutralizing the motion of a ship in the manner to be described.

It consists, 2nd, in the arrangement of hinged boards, corks and air-tight tubes forming a berth and life-boat, as hereinafter described.

To enable others, skilled in the art, to make and use my invention, I will proceed to describe its construction and operation.

The lower part of this combined berth and life boat consists of side boards 3, 4, 7 and 8 (see Fig. 1) which are made in halves hinged together at the outside; also of a bottom made in two parts U, Q, hinged together at W, X, W, (see Fig. 6); and stern and bow boards. Each of the latter is made in two parts L, L, hinged together and the lower part L, hinged to the bottom at V, inside of the boat, as seen in Fig. 6. The upper part of this combined berth and life boat consists of two side boards (each made in two parts 1, 2, and 5, 6,) and of the upper parts L, of the bow and stern boards. The

parts 5, 6, and 1, 2, are hinged to lower side boards 3, 4, at the inside as seen in Fig. 1, and when turned up as represented in said figure, the upper boards L, fit between the ends of the boards 5, and 1, and between those of boards 6, and 2, so as to serve as braces for sustaining the side boards in position.

The joint between the upper side boards is made of zig-zag shape, as seen in Fig. 3. A strip of india-rubber S, is placed into the inner part of this zig-zag slot and the rest of it is filled up with a strip of wood, as seen at N, in order to make an air-tight joint. Similar strips of elastic material are placed between all the other joints, as seen at R', (Fig. 3) and R'', (Fig. 2).

It will be understood that the boat is so hinged together for the purpose of folding it up and packing it into a small space such as a traveler's trunk, if not wanted for immediate use.

Corks 9, 10, 11, and 12, are secured to the bow and stern, and air-tight tubes J, to the upper edges of the side boards of the board, in order to increase the buoyancy of the boat and secure it against being swamped.

This boat is of such dimensions that it can be used as a berth affording ample space for a person to sleep in. Its sides are provided with four pivots G, which serve to hang the boat to the outer ends of two cross bars E, E, by means of four suspension rods H, H, H, H. The two cross bars are secured to a rock shaft D, which has its bearings in two frames B, C, B, C. These frames are fastened to the ship in suitable places for hanging the berths.

It will be understood that the berth thus hung upon a rock-shaft is free to swing forward and backward as well as to either side, in relation to the frame work B, C, B, C, and to the ship. Or, if the ship moves in either of said directions, the berth will be allowed to remain level. In this manner the berth is hung so as to compensate the rolling or pitching motion of the ship, and thus the

person occupying the berth is protected from sea-sickness and rests comfortably however violent the motion of the ship may be.

In cases of danger, the berth can easily be unhooked from the suspension rods H, and is then ready to be used as a life boat.

What I claim as my invention and desire to secure by Letters Patent, is—

1. The arrangement of a rock shaft D, cross-bars E, and suspension rods H, in combination with a boat-berth for the purpose

of neutralizing the motion of a ship, substantially as set forth.

2. The arrangement of hinged boards 3, 4, 1, 2, U, L, L, corks 9, 10, 11, 12, and airtight tubes J, forming a berth and life boat, substantially as set forth.

THOMAS S. BROWN.

Witnesses:

MARCUS SCHERALE,
TERNS MASTERSON.