



(22) Date de dépôt/Filing Date: 2002/12/23
 (41) Mise à la disp. pub./Open to Public Insp.: 2003/07/07
 (45) Date de délivrance/Issue Date: 2007/11/20
 (30) Priorité/Priority: 2002/01/07 (DE10200309)

(51) Cl.Int./Int.Cl. *E21B 15/00* (2006.01),
B23B 45/14 (2006.01), *B25D 17/28* (2006.01),
E21B 19/00 (2006.01), *E21B 19/08* (2006.01),
E21B 19/086 (2006.01), *E21C 35/00* (2006.01),
F16M 11/00 (2006.01)

(72) Inventeurs/Inventors:
 RICHTER, MARTIN, DE;
 GASSER, GERHARD, AT;
 MEISENBICHLER, KARL, AT;
 NEUPER, KARL, AT

(73) Propriétaire/Owner:
 HILTI AKTIENGESELLSCHAFT, LI

(74) Agent: GIERCZAK, EUGENE J. A.

(54) Titre : DISPOSITIF DE DEPLACEMENT ET DE SUPPORT POUR OUTIL ELECTRIQUE PORTATIF
 (54) Title: DISPLACEMENT AND SUPPORT DEVICE FOR A PORTABLE POWER TOOL

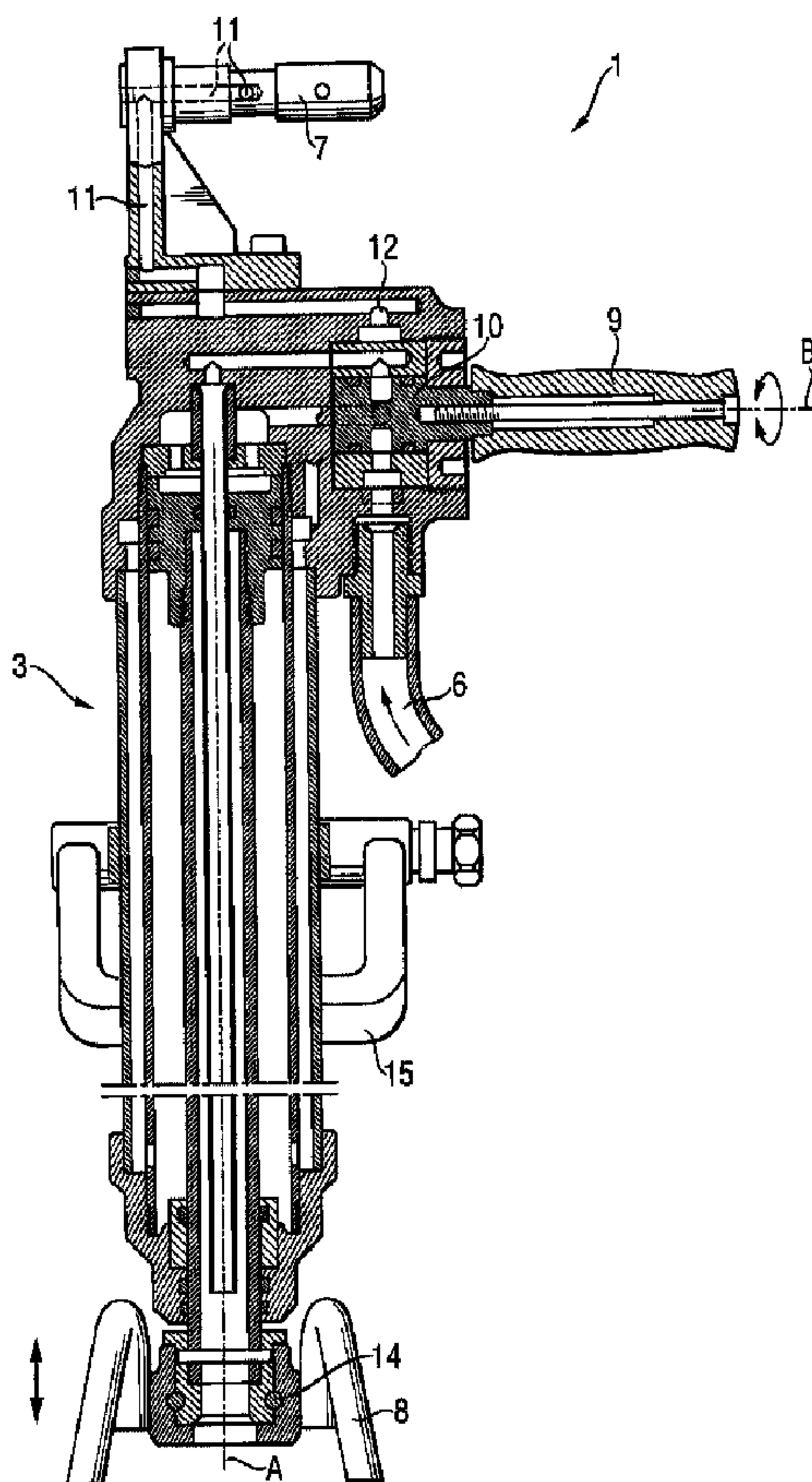

(57) Abrégé/Abstract:

A displacement and support device including a power cylinder provided at its opposite ends, respectively, with an assembly element for connecting the power cylinder with power tool and a support leg, a control valve for controlling operation of the power

(57) **Abrégé(suite)/Abstract(continued):**

cylinder , and a manually rotationally adjustable actuation member for actuating the control valve , with the actuation member being formed as a handle extending transverse to an axis of the power cylinder and rotationally adjustable about a handle axis within a rotational angle of 180° that encompasses an entire control region of the control valve.

ABSTRACT OF THE DISCLOSURE

A displacement and support device including a power cylinder provided at its opposite ends, respectively, with an assembly element for connecting the power cylinder with power tool and a support leg, a control valve for controlling operation of the power cylinder, and a manually rotationally adjustable actuation member for actuating the control valve, with the actuation member being formed as a handle extending transverse to an axis of the power cylinder and rotationally adjustable about a handle axis within a rotational angle of 180° that encompasses an entire control region of the control valve.

BACKGROUND OF THE INVENTION

1. Field of the Invention

The present invention relates to a displacement and support device for a portable power tool, in particular, a percussion power tool, preferably, for forming shot holes during underground mining works.

2. Description of the Prior Art

Such portable power tools, which are driven hydraulically, pneumatically, or electrically, weight about 15 kg and are usually equipped with an elongate, water-flushed drill rod which is rotatably and axially displaceable, within narrow limits, secured in the power tool and is provided at its free end with a drill bit made of a hard material and having a diameter of about 35 mm.

German Patent DE 74833 discloses a portable electrical rock power drill for drilling shot holes during underground mining works and provided with an elongate water-flushed drilling rod with a drill bit made of hard material, and a support device. The drill rod displacement is effected with a hydraulic cylinder of which the telescopic drill rod forms a part.

U.S. Patent No. 4,000,873 discloses a portable power tool with an easily mountable displacement and support device which is supported on the ground and simultaneously applies a controlled displacement force to the drill. For forming substantially horizontal holes, the displacement and support device is inclined rearwardly and downwardly.

U.S. Patent No. 1,464,486 discloses a rotary-percussion power tool having a one-leg support and a discretely controlled control valve rotatable about 360°. A sensitive manual control of the displacement and support device with such a valve is not possible.

U.S. Patent No. 1,151,261 discloses a fluid-driven percussion power tool with an axially arranged, one-leg support that is formed as a double-action cylinder and displacement of which is constantly controlled by a radial, rotationally adjustable worm gear valve by effecting several revolutions. For a manual control over the entire control region of the displacement and support device, turning over of the controlling head is necessary.

An object of the present invention is a displacement and support device that can be comfortably controlled manually with one hand over its entire control region.

SUMMARY OF THE INVENTION

10 This and other objects of the present invention, which will become apparently hereinafter, are achieved by providing a displacement and support device for a portable power tool and including a fluid-operated power cylinder, assembly means provided at one end of the power cylinder for connecting the power cylinder with the power tool; a support leg provided at another, opposite end of the power cylinder, a control valve for controlling operation of the power cylinder, and a manually rotationally adjustable actuation member for actuating the control valve, with the actuation member being formed as a handle extending transverse to an axis of the power cylinder and rotationally adjustable about a handle axis within a rotational angle of 180° and, preferably, 90° that encompasses the entire control region of the control valve.

20

With the entire control region of the control valve being within a rotational angle of the actuation member of 180° or 90°, a comfortable control and fixation of the displacement and support device becomes possible, without a need to turn the controlling hand over and over again.

Advantageously, the continuously controlled control valve is formed as a

rotary valve, which makes possible to continuously control, in a technological simple manner, the flow rate by adjusting the rotary position of the valve.

Advantageously, the power cylinder is formed as a double-action cylinder, which provides for an easy withdrawal of the drill rod from the bore or hole.

Advantageously, the assembly means is formed as partially torsion-free bolt connection element extending sideways on outside of the power cylinder and transverse to the drill axis and through an eyelet provided on the power tool, securing the power cylinder to the power tool. Within the bolt connection element, there is provided a fluid conduit through which fluid, which is fed through the pressure hose into the displacement and support device is fed to the power tool. The fluid, which enters the displacement and support device flows to the conduit through a junction.

Advantageously, the power cylinder is hydraulically operated in which the water, which is necessary for cooling and flushing the drill bit, is used as a pressure medium.

Advantageously, the support leg, which can be formed as an elongate member, is connected with the power cylinder by a claw member securable with a cross-pin.

Advantageously, the support device includes a stirrup-shaped handle rotatably and linearly displaceably mounted on the power cylinder, which provides for an easy transportation of the displacement and support device with two hands.

The novel features of the present invention, which are considered as characteristic for the invention, are set forth in the appended claims. The invention itself, however, both as to its construction and its mode of operation, together with

additional advantages and objects thereof, will be best understood from the following detailed description of preferred embodiment, when read with reference to the accompanying drawings.

BRIEF DESCRIPTION OF THE DRAWINGS

In the Drawings:

Fig. 1 shows a schematic view illustrating the use of a displacement and support device according to the present invention;

Fig. 2 shows a cross-sectional view of a displacement and support device according to the present invention along line II-II in Fig. 3; and

Fig. 3 shows a side view of a displacement and support device according to the present invention.

DETAILED DESCRIPTION OF THE PREFERRED EMBODIMENT

Fig. 1 shows the use of a displacement and support device with a portable power tool 1 used in underground mining and provided with a rotatably and percussion driven, water-flushed, elongate drill 2. The displacement and support device is formed as power cylinder 3 that supports the power tool 1 against a floor and, simultaneously, applies to the drill 2 an acting in the operational direction of the drill 2, controlled displacement force. The power cylinder 3, which is inclined rearwardly, is manually guided and controlled by a user 5. Water is fed to the working or power cylinder 3 through a pressure hose 6, and to the drill 2 through the power tool 1.

The power cylinder 3, which is shown in Figs. 2-3, is formed as a hydraulically driven, double-action, power cylinder and is provided, at one of its end, with an

assembly element 7 easily securable to the power tool 1 and, at another of its end, with a support leg 8. The power cylinder 3 is manually controlled by a control valve 10 which is formed as a rotary valve. The operation of the control valve 10 is controlled by a manually rotationally adjustable actuation member 9. The actuation member 9 is formed as a handle extending transverse to the axis A of the power cylinder 3 and rotatable about the handle axis B. The actuation member 9 is rotationally adjustable within a rotational angle of 180°.

10 The assembly element 7 is formed as a partially torsion-free bolt connection element extending sideways transverse to the drill axis and through an eyelet 16 provided on the power tool 1, securing the power cylinder 3 to the power tool 1. Within the bolt connection element, there is provided a fluid conduit 11 through which fluid, which is fed through the pressure hose 6 into the displacement and support device, is fed to the power tool 1. The fluid, which enters the displacement and support device, flows to the conduit 11 through a junction 12.

The support leg 8 is secured to another end of the power cylinder 3 by a claw 14 that can be tangentially withdrawn. The claw 14 is secured by a cross-pin 13. A pivotable and linearly displaceable stirrup shaped handle 15 is provided on the power cylinder 3.

20 Though the present invention was shown and described with references to the preferred embodiment, such is merely illustrative of the present invention and is not to be construed as a limitation thereof and various modifications of the present invention will be apparent to those skilled in the art. It is therefore not intended that the present invention be limited to the disclosed embodiment or details thereof, and the present invention includes all variations and/or alternative embodiments with the spirit and scope of the present invention as defined by the appended claims.

The embodiments of the invention in which an exclusive property or privilege is claimed are defined as follows:

1. A displacement and support device for a portable power tool, comprising:
 - a fluid-operated power cylinder;
 - assembly means provided at one end of the power cylinder for connecting the power cylinder with the power tool;
 - a support leg provided at another, opposite end of the power cylinder;
 - a control valve for controlling operation of the power cylinder; and
 - a manually rotationally adjustable actuation member for actuating the control valve, the actuation member being formed as a handle extending transverse to an axis of the power cylinder and rotationally adjustable about a handle axis within a rotational angle of 180° that encompasses an entire control region of the control valve;

wherein the assembly means is formed as a partially torsion-free bolt connection element extending transverse to the power tool axis, and projects sideways on one side of the one end of the power cylinder and extends through an eyelet provided on the power tool.
2. A displacement and support device according to claim 1, wherein the handle-shaped actuation member is rotationally adjustable within a rotational angle of 90° that encompass the entire adjustable region of the control valve.
3. A displacement and support device according to claim 1, wherein the control valve is formed as a continuously adjustable rotary valve.

4. A displacement and support device according to claim 1, wherein the power cylinder is formed as a double-action cylinder.
5. A displacement and support device according to claim 1, wherein a fluid conduit is formed in an interior of the bolt connection element and extends along a portion of a longitudinal extent thereof.
6. A displacement and support device according to claim 1, wherein the power cylinder is hydraulically operated.
7. A displacement and support device according to claim 1, wherein the support leg is formed as an elongate member.
8. A displacement and support device according to claim 1, comprising a claw member securable with a cross-pin for connecting the support leg with another end of the power cylinder.
9. A displacement and support device according to claim 1, comprising a stirrup-shaped handle rotatably and linearly displaceably mountable on the power cylinder.
10. A displacement and support device for a portable power tool, comprising:
 - a fluid-operated power cylinder;
 - assembly means comprising a partially torsion-free bolt connection element extending transverse to the axis of the power cylinder for connecting the power cylinder with the power tool;
 - a support leg provided at another, opposite end of the power cylinder;

a control valve for controlling operation of the power cylinder;

a manually rotationally adjustable actuation member for actuating the control valve, the actuation member being formed as a handle extending transverse to an axis of the power cylinder and rotationally adjustable about a handle axis; and

a fluid conduit disposed within said assembly means.

11. A displacement and support device according to claim 10 wherein said fluid conduit is disposed within a portion of said bolt connection element.

12. A displacement and support device according to claim 11 wherein said handle is rotatable within a rotational angle of 180°.

13. A displacement and support device according to claim 10 wherein the control valve is formed on a continuously adjustable rotary valve.

Fig. 1

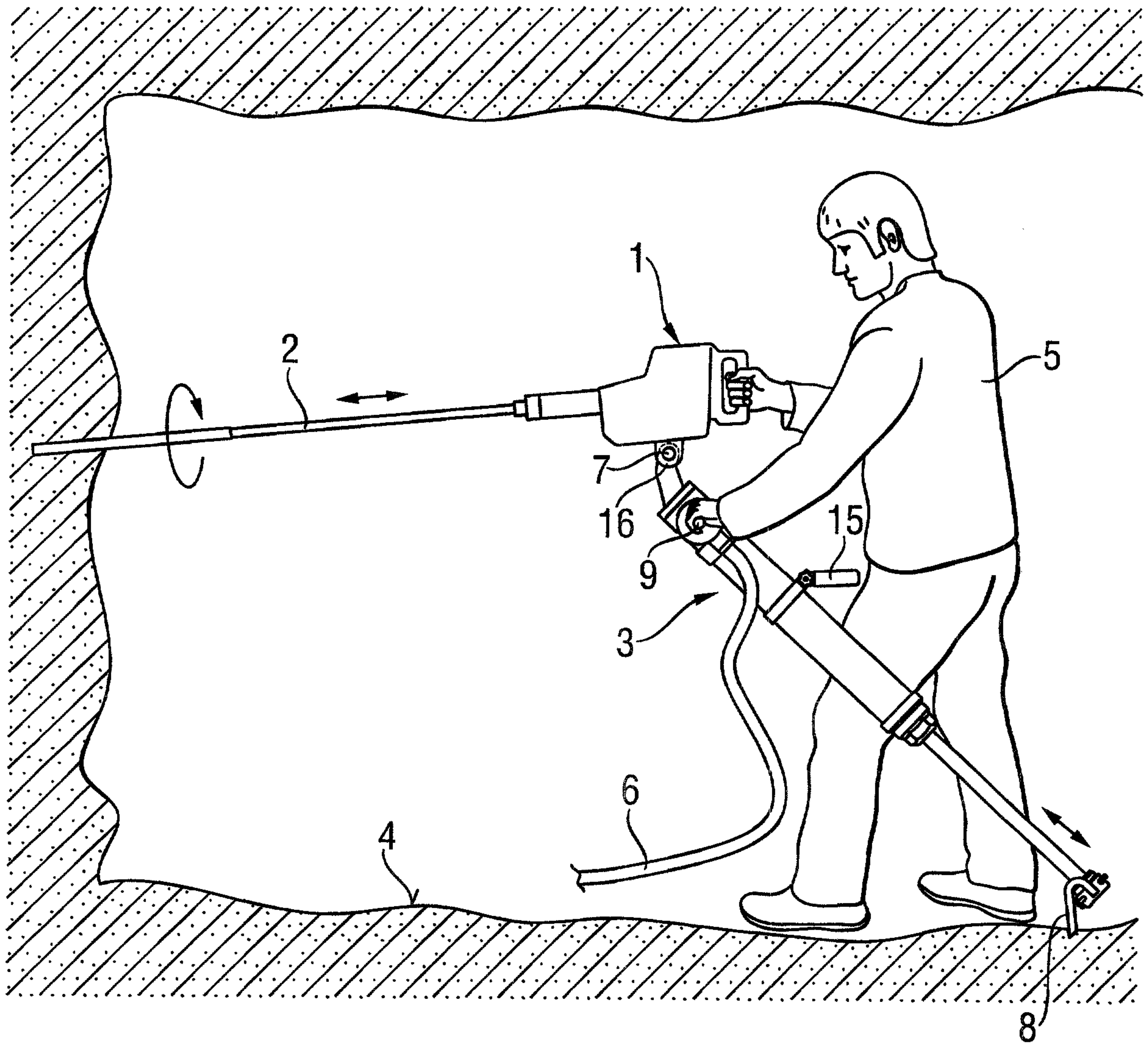

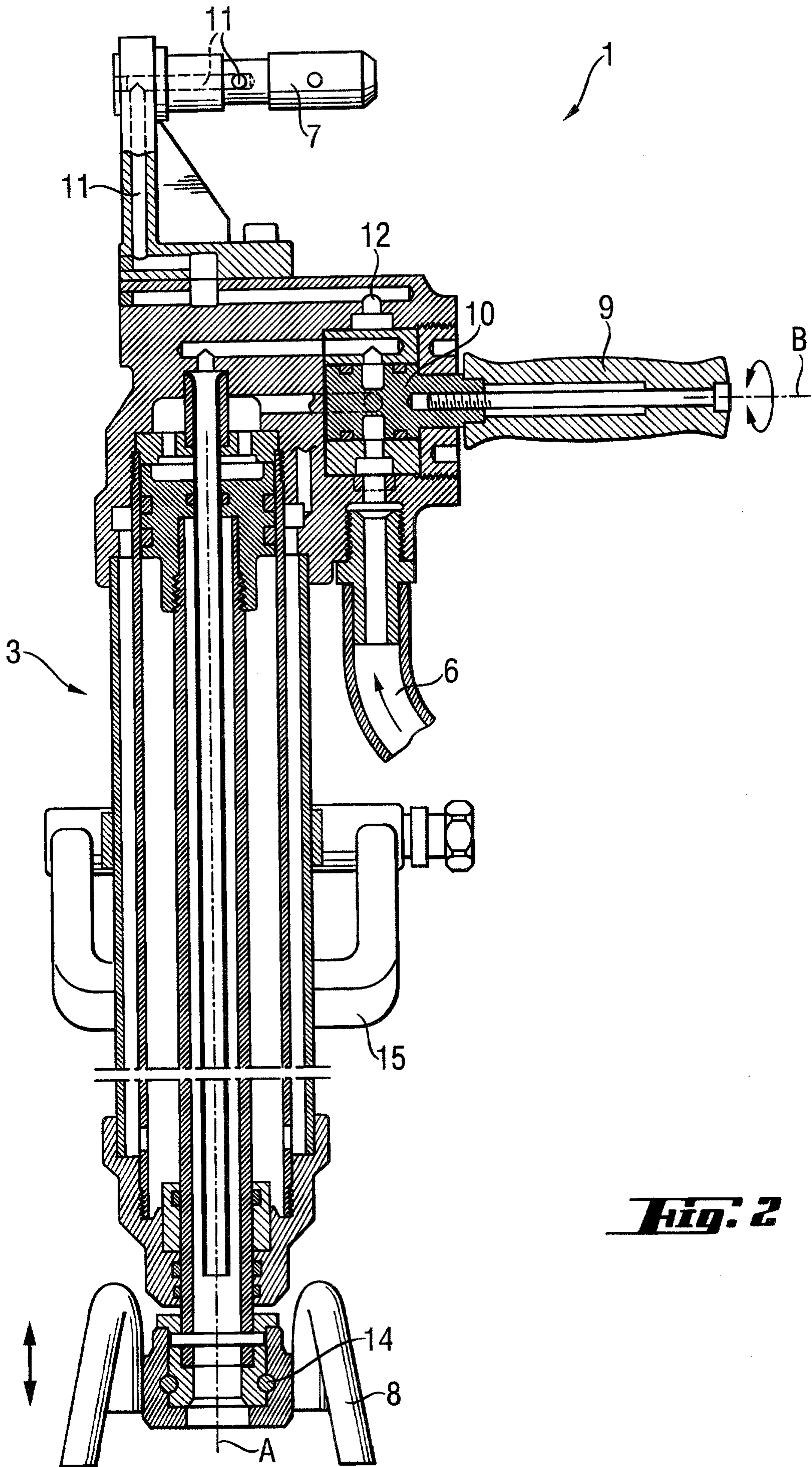

Fig. 2

Fig. 3

