

C. H. BISSELL & D. C. GIDLEY.
 CORD SUPPORT.
 APPLICATION FILED FEB. 4, 1911.

1,129,782.

Patented Feb. 23, 1915.

Fig-1-

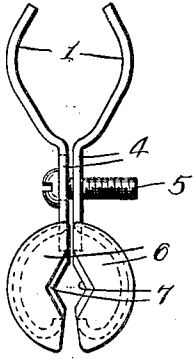

Fig-2-

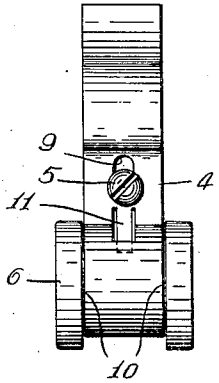

Fig-3-

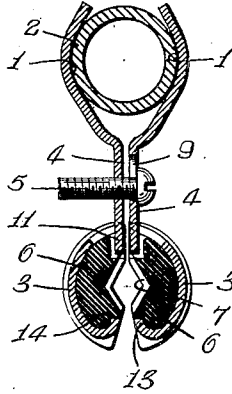

Fig-4-

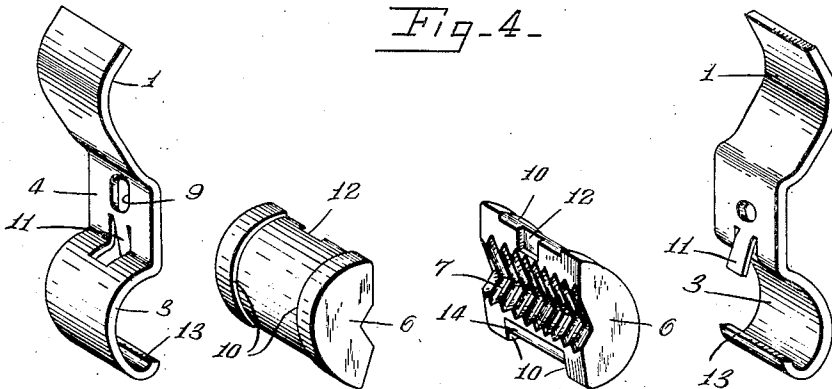
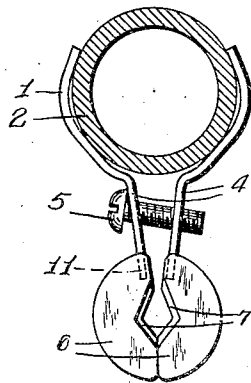

Fig-6-



Fig-5-



WITNESSES:

Chas. Young
J. B. Smith

INVENTORS
Carl H. Bissell
Daniel C. Gidley
 BY *Parsons, Hackett & Bolles*
 ATTORNEYS

UNITED STATES PATENT OFFICE.

CARL H. BISSELL, OF SYRACUSE, AND DANIEL C. GIDLEY, OF ALBANY, NEW YORK,
ASSIGNORS TO CROUSE-HINDS COMPANY, OF SYRACUSE, NEW YORK, A CORPORATION OF NEW YORK.

CORD-SUPPORT.

1,129,782.

Specification of Letters Patent.

Patented Feb. 23, 1915.

Application filed February 4, 1911. Serial No. 606,453.

To all whom it may concern:

Be it known that we, CARL H. BISSELL and DANIEL C. GIDLEY, respectively of Syracuse, in the county of Onondaga, and of Albany, in the county of Albany, State of New York, have invented a certain new and useful Cord-Support, of which the following is a specification.

This invention has for its object the production of means for supporting the insulated wires or cords to which an electrical appliance, as a lamp, is attached; and the invention consists in the combinations and constructions hereinafter set forth and claimed.

In describing this invention reference is had to the accompanying drawing in which like characters designate corresponding parts in all the views.

Figures 1 and 2 are elevations of our cord support, taken at a right angle to each other. Fig. 3 is a sectional view thereof, the conduit to which the support is secured being also shown in section. Fig. 4 is an unassembled view of parts of this cord support. Fig. 5 is a view similar to Figs. 1 and 3 illustrating the adaptability of the cord support to a conduit of a different diameter. Fig. 6 illustrates one application of our invention.

This cord support comprises, generally, means for engaging the supporting element and the cord and means for clamping the engaging means in position.

Preferably our cord support comprises two opposing separable sections duplicates of each other, each section having a jaw 1 at one end for engaging the supporting element as an electrical conduit 2, a jaw 3 at its opposite end for holding the cord, and a shank portion 4 connecting the jaws 1 and 3. A clamping member, as a screw 5, transversely through the shank portions 4. The jaws 3 carry parts 6 of insulation, each having angularly arranged working faces 7 for cooperating with the corresponding faces 7 of the other part and gripping the cord 8. The sections of our cord support are formed of sheet metal and the arms or jaws 1 are adaptable to conduits of different sizes as shown in Figs. 3 and 5.

When the jaws 1 are attached to conduits of comparatively large size, the shank portions 4 separate and the insulating parts 6

meet at their lower ends. As shown in Fig. 5. One of the shank portions is formed with a slot 9 for permitting the necessary movement of the screw 5 during the separation of the shank portions, this screw preferably threading into the other shank portion.

The jaws 3 are arcuate in form, and each part 6 is preferably semi-cylindrical in general form and fits the corresponding jaw 3 and is provided with beads or shoulders 10 at its ends which engage the side edges of the corresponding jaw 3 and prevent endwise movement of said part 6. Each part 6 is held from displacement from the jaw 3 by suitable means, here shown as comprising a tongue 11 struck from the shank portion 4 and arcuate jaw of each section, and extending into a notch 12 formed in the inner face of each part 6 above the working face 7 thereof. Such means also includes an in-turned lip 13 at the lower end of each jaw 3 and extending into a groove 14 formed in the corresponding part 6 below the working face of said part 6.

This cord support is preferably adapted to be used in connection with conduit work in which the wires are led from the conduit through an outlet box 15, the wires in the box being connected to the cord 8, and in use the jaws 1 are clamped onto the conduit 2 and the insulating parts 6 carried by the jaws 3 are clamped onto the cord 8. However, the jaws 1 when necessary may be clamped to any other suitable supporting element.

What we claim is:

An electric cord support comprising opposing separable sections formed of sheet metal, each having a jaw for cooperating with the corresponding jaw of the other section and clamping a supporting element, a jaw at its opposite end for cooperating with the corresponding jaw of the other section and holding the cord, and a shank portion connecting the jaws, parts of insulation carried by the cord holding jaws and having working faces for engaging the cord, and each section having a tongue struck therefrom for engaging one of said parts, and the end edge of each of the cord holding jaws being turned inwardly for engaging respectively the parts held by said jaws and cooperating with the tongues for holding said parts from detachment and the insulat-

ing parts having peripheral shoulders at their ends for engaging the side edges of the jaws, and a clamping member extending through the shank portions, substantially
5 as and for the purpose described.

In testimony whereof, we have hereunto signed our names in the presence of two at-
testing witnesses, at Syracuse, in the county

of Onondaga, in the State of New York,
this 24th day of January, 1911.

CARL H. BISSELL.
DANIEL C. GIDLEY.

Witnesses:

G. B. SMITH,
S. DAVIS.