

**(12) STANDARD PATENT APPLICATION (11) Application No. AU 2011205020 A1**  
**(19) AUSTRALIAN PATENT OFFICE**

(54) Title  
**Gaming machine**

(51) International Patent Classification(s)  
**A63F 9/00 (2006.01)**

(21) Application No: **2011205020** (22) Date of Filing: **2011.07.27**

(30) Priority Data

(31) Number (32) Date (33) Country  
**2010-252081 2010.11.10 JP**

(43) Publication Date: **2012.05.24**

(43) Publication Journal Date: **2012.05.24**

(71) Applicant(s)  
**Aruze Gaming America, Inc.; Universal Entertainment Corporation**

(72) Inventor(s)  
**Kido, Katsuhiro; Munakata, Hiroki**

(74) Agent / Attorney  
**Davies Collison Cave, 1 Nicholson Street, Melbourne, VIC, 3000**

ABSTRACT OF THE DISCLOSURE

A gaming machine of the present invention stores a bet area on which a bet is placed and a game value placed as the bet in each gaming terminal, rotates and stops the wheel to determine a resulting symbol from the plurality of symbols, awards a payout based on the resulting symbol and the odds set for the bet area on which the bet is placed in the gaming terminal, and then adjusts the payout rate by changing the odds set for the bet areas in the gaming terminals.

5

10

2011205020 27 Jul 2011

*Australian Patents Act 1990 – Regulation 3.2*

**ORIGINAL COMPLETE SPECIFICATION  
STANDARD PATENT**

Invention Title

Gaming machine

The following statement is a full description of this invention, including the best method of performing it known to me/us:-

BACKGROUND OF THE INVENTION

1. Field of the Invention

5 [0001]

The present invention relates to a gaming machine which awards a payout, according to a resulting symbol on a wheel which rotates on the premise a game value is bet via a gaming terminal.

10

2. Description of Related Art

[0002]

To date, there has been a gaming machine having a big wheel (roulette) which is rotated and stopped, and is visible to a plurality of players playing a game. Based on the resulting symbol on the wheel, the gaming machine awards a payout to a player.

15

[0003]

For example, Australian patent No. 2005248935 discloses a gaming machine which rotates and stops a big wheel, awards a payout to the player based on the resulting symbol on the big wheel. This gaming machine further enables additional betting for a bonus feature, and awards an additional payout based on the winning result of the bonus feature.

20

25

[0004]

Further, Australian patent No. 2005299238 discloses a gaming machine which rotates and stops a big wheel, awards a payout to the player based on the resulting symbol on the big wheel. This gaming machine further enables additional betting for a bonus feature, and displays a selection screen on the terminal of the player having placed a bet for the bonus feature upon winning the bonus feature. Then, an additional payout is awarded, based on the selection entered by the player.

[0005]

Further, U.S. Patent No. 6659866 discloses a gaming machine including a plurality of player terminals, a processor, and a dealer terminal, in which a manual roulette device is rotated and stopped and the processor directly awards a payout to a player terminal, based on the resulting symbol on the manual roulette device.

[0006]

However, in the above mentioned traditional gaming machines, the big wheel used in a game and the manual roulette device are rotated manually by an operator and is stopped naturally. Therefore, effects to the game are limited and improvement of the entertainment characteristic has been difficult.

[0007]

In view of the above problem, the present invention is made, and it is an object of the present invention to provide a gaming machine capable of achieving a high entertainment characteristic, in a game in which a wheel is rotated and stopped.

SUMMARY OF THE INVENTION

[0008]

A gaming machine of the present invention includes:  
10 a wheel having a plurality of symbol arrangement areas in which a plurality of symbols are arranged on the same plane, respectively, the wheel being capable of rotating in such a manner that the symbols are visible; a plurality of gaming terminals each having a display for displaying a  
15 plurality of bet areas corresponding to the symbols, each gaming terminal structured to receive a bet of a game value on a bet area and to award a payout based on odds set for the bet area; and a center controller which stores a bet area on which a bet is placed and a game value  
20 placed as the bet in each gaming terminal, determines a resulting symbol from the plurality of symbols through the rotation of the wheel, and awards a payout based on the resulting symbol and the odds set for the bet area on which the bet is placed in the gaming terminal, wherein  
25 the center controller adjusts a payout rate by changing

the odds set for the bet areas of the gaming terminals.

[0009]

5 With the above structure, the wheel used in the game is automatically rotated or stopped by controlling the center controller. Thus, unlike a simple roulette game, various effects can be provided to the game, and the entertainment characteristic of the game is improved. Further, the payout rate is adjustable by changing the odds. For example, by adjusting the payout rate according to the operation rate of the gaming machine, the operation rate could be effectively improved.

[0010]

15 Further, a gaming machine of the present invention includes: a wheel having a plurality of symbol arrangement areas in which a plurality of symbols are arranged on the same plane, respectively, the wheel being capable of rotating in such a manner that the symbols are visible; a plurality of gaming terminals each having a display for displaying a plurality of bet areas corresponding to the symbols, each gaming terminal structured to receive a bet of a game value on a bet area and to award a payout based on odds set for the bet area; and a center controller which stores a bet area on which a bet is placed and a game value placed as the bet in each gaming terminal, 20 determines a resulting symbol from the plurality of 25

symbols through the rotation of the wheel, and awards a payout based on the resulting symbol and the odds set for the bet area on which the bet is placed in the gaming terminal, wherein the payout rate may be adjusted by changing the number of symbols arranged in the symbol arrangement areas

[0011]

With the above structure, the wheel used in the game is automatically rotated or stopped by controlling the center controller. Thus, unlike a simple roulette game, various effects can be provided to the game, and the entertainment characteristic of the game is improved. Further, the payout rate is adjustable by changing the number of symbols. For example, by adjusting the payout rate according to the operation rate of the gaming machine, the operation rate could be effectively improved.

[0012]

Further, the gaming machine of the present invention may be adapted so that the center controller switches a form of displaying the odds set for the bet areas on the display of the gaming terminal.

[0013]

With the above structure, the form of displaying the odds on the display of the gaming terminal is switchable. Therefore, the form of displaying can be adjusted to a



form that is easiest to see for the players while playing the game.

BRIEF DESCRIPTION OF THE DRAWINGS

5 [0014]

FIG. 1 is a diagram showing the entire gaming machine related to an embodiment of the present invention.

FIG. 2 is an explanatory diagram showing a function flow of the gaming machine related to the embodiment of the present invention.  
10

FIG. 3 is an explanatory diagram showing a roulette device of the gaming machine related to the embodiment of the present invention.

FIG. 4 is an enlarged view showing a part of the wheel of the roulette device related to the embodiment of the present invention.  
15

FIG. 5A is a diagram explaining the operation of the wheel of the roulette device related to the embodiment of the present invention.

FIG. 5B is a diagram explaining the operation of the wheel of the roulette device related to the embodiment of the present invention.  
20

FIG. 5C is a diagram explaining the operation of the wheel of the roulette device related to the embodiment of the present invention.  
25

FIG. 6D is a diagram explaining the operation of the wheel of the roulette device related to the embodiment of the present invention.

5 FIG. 6E is a diagram explaining the operation of the wheel of the roulette device related to the embodiment of the present invention.

FIG. 6F is a diagram explaining the operation of the wheel of the roulette device related to the embodiment of the present invention.

10 FIG. 7A is a diagram explaining the operation of the wheel of the roulette device related to another embodiment of the present invention.

FIG. 7B is a diagram explaining the operation of the wheel of the roulette device related to the other  
15 embodiment of the present invention.

FIG. 7C is a diagram explaining the operation of the wheel of the roulette device related to the other embodiment of the present invention.

FIG. 8 is a diagram explaining a lever device of a  
20 station related to the embodiment of the present invention.

FIG. 9 is a diagram explaining a display mode of the display of the station related to the embodiment of the present invention.

FIG. 10 is an explanatory diagram showing another  
25 display mode of the display of the station related to the

embodiment of the present invention.

FIG. 11 is an explanatory diagram showing an electric structure of the gaming machine related to the embodiment of the present invention.

5 FIG. 12 is an explanatory diagram showing the internal structure of a mass controller of the gaming machine related to the embodiment of the present invention.

10 FIG. 13 is an explanatory diagram showing the internal structure of the station related to the embodiment of the present invention.

FIG. 14 is an explanatory diagram showing a bet information managing table of the station related to the embodiment of the present invention.

15 FIG. 15 is an explanatory diagram showing a lever operation time table of the station related to the embodiment of the present invention.

FIG. 16 is an explanatory diagram showing a station managing table of the mass controller related to the embodiment of the present invention.

20 FIG. 17 is an explanatory diagram showing a wheel rotation speed table of the mass controller related to the embodiment of the present invention.

25 FIG. 18 is an explanatory diagram showing a wheel stop-effect pattern table of the mass controller related to the embodiment of the present invention.

FIG. 19A is an explanatory diagram showing a payout pattern table of type A of the mass controller related to the embodiment of the present invention.

5 FIG. 19B is an explanatory diagram showing a payout pattern table of type B of the mass controller related to the embodiment of the present invention.

FIG. 19C is an explanatory diagram showing a payout pattern table of type C of the mass controller related to the embodiment of the present invention.

10 FIG. 20 is an explanatory diagram showing an exemplary rotation speed curve of the wheel related to the embodiment of the present invention.

FIG. 21 is a flowchart of the station side game process which is executed by a station controller related to the embodiment of the present invention.

15 FIG. 22 is a flowchart of the mass controller side game process which is executed by a mass controller related to the embodiment of the present invention.

20 DESCRIPTION OF THE PREFERRED EMBODIMENTS

[0015]

The following describes a preferable embodiment of the present invention, with reference to attached drawings.

[0016]

25 (Overview of the gaming machine)

As shown in FIG. 1 to FIG. 3, a gaming machine 1 of the present embodiment includes: a wheel 51 having a plurality of spots 52 in which a plurality of symbols 21 are arranged on the same plane, respectively, the wheel being capable of rotating in such a manner that the symbols 21 are visible; a pointer 53 fixed apart from the rotatable wheel 51, which points one of the spots 52; a plurality of stations 10 (10a, 10b, 10c, 10d, 10e) each having a lever device 40 for starting rotation of the wheel 51, and a display 20 for displaying a plurality of bet areas 36 corresponding to the symbols 21, each station structured to receive a bet of a game value on a bet area 36 and to award a payout based on odds set for the bet area 36; lever activating units 109 and 712 which activate the lever device 40 of any of the stations 10, based on a predetermined condition; and a mass controller 70, wherein the mass controller 70 is programmed to execute the processes of: (a1) storing a bet area 36 on which a bet is placed and a game value placed as the bet in each station 10, (a2) determining a resulting symbol from the plurality of symbols 21, (a3) rotating the wheel 51 based on an operation of the lever device 40 in one of the plurality of stations 10, whose lever device 40 has been activated by the lever activating units 109 and 712, (a4) stopping the wheel 51 being rotated so that the pointer 53 points

at one of the spots 52 with the resulting symbol 21, and (a5) awarding a payout based on the resulting symbol 21 and the odds set for the bet area 36 on which the bet is placed in the station 10.

5 [0017]

Further, the mass controller 70 compares the game values bet by the stations 10 (10a, 10b, 10c, 10d, 10e), respectively; controls the lever activating units 109 and 712 to activate the lever of the station 10 having bet the greatest game value among the plurality of gaming terminals; and rotates the wheel 51 based on the operation of the lever device 40 having been activated.

[0018]

15 Further, the mass controller 70 controls the lever activating units 109 and 712 to activate the lever device 40 of a station 10 determined among the plurality of the stations 10, according to a predetermined sequence; and rotates the wheel 51 based on the operation of the lever device 40 having been activated.

20 [0019]

Further, the lever activating units 109 and 712 prohibit activation of the lever device 40 in a station 10 if the amount of game value bet from the station 10 falls short of a predetermined amount.

25 [0020]

Further, each of the stations 10 has a lever speed measurement/determination unit 103 which measures the operation period of the lever device 40; and the mass controller 70 stores the operation period of the lever device 40 measured by the lever speed measurement/determination unit 103, and rotates the wheel 51 at a rotation speed corresponding to the operation period, based on an operation of the lever device 40 in one of the plurality of stations, whose lever has been activated by the lever activating units 109 and 712.

[0021]

Further, the gaming machine 1 of the present embodiment includes: a wheel 51 having a plurality of spots 52 in which a plurality of symbols 21 are arranged on the same plane, respectively, the wheel being capable of rotating in such a manner that the symbols 21 are visible; a pointer 53 fixed apart from the rotatable wheel 51, which points one of the spots 52; a motor 61 which rotates the wheel 51; a plurality of stations 10 (10a, 10b, 10c, 10d, 10e) each having a lever device 40 for starting rotation of the wheel 51, and a display 20 for displaying a plurality of bet areas 36 corresponding to the symbols 21, each station structured to receive a bet of a game value on a bet area 36 and to award a payout based on odds set for the bet area 36; lever activating units 109 and

712 which activate the lever device 40 of any of the stations 10, based on a predetermined condition; and a rotation speed data storage 713 which stores rotation speed data regulating the rotation speed for the rotation angle of the wheel 51; and a mass controller 70 wherein the mass controller 70 is programmed to execute the processes of: (b1) storing a bet area 36 on which a bet is placed and a game value placed as the bet in each station 10, (b2) determining a resulting symbol from the plurality of symbols 21, (b3) rotating the wheel 51 based on an operation of the lever device 40 in one of the plurality of stations 10, whose lever device 40 has been activated by the lever activating units 109 and 712, (b4) controlling the motor 61 to change the rotation speed of the wheel 51 based on the rotation speed data stored in the rotation speed data storage 713, (b5) stopping the wheel 51 being rotated so that the pointer 53 points at one of the spots 52 with the resulting symbol 21, and (b6) awarding a payout based on the resulting symbol and the odds set for the bet area 36 on which the bet is placed in the station 10.

[0022]

The rotation speed data regulates the rotation speed so that the rotation is accelerated or decelerated relative to the rotation angle within a predetermined



period; and the mass controller 70 controls the motor 61 to accelerate or decelerate the rotation of the wheel based on the rotation speed data stored in the rotation speed data storage 713.

5 [0023]

The mass controller 70 controls the motor 61 to rapidly decelerate the rotation of the wheel 51 and then gradually decelerate the rotation of the wheel 51 to stop the wheel 51, based on the rotation speed data stored in  
10 the rotation speed data storage 713.

[0024]

Further, the gaming machine 1 of the present embodiment includes: a wheel 51 having a plurality of spots 52 in which a plurality of symbols 21 are arranged  
15 on the same plane, respectively, the wheel being capable of rotating in such a manner that the symbols 21 are visible; a pointer 53 fixed apart from the rotatable wheel 51, which points one of the spots 52; symbol LEDs 37 which light up the symbols 21; a plurality of stations 10 (10a,  
20 10b, 10c, 10d, 10e) each having a lever device 40 for starting rotation of the wheel 51, and a display 20 for displaying a plurality of bet areas 36 corresponding to the symbols 21, each station structured to receive a bet of a game value on a bet area 36 and to award a payout  
25 based on odds set for the bet area 36; lever activating

units 109 and 712 which activate the lever device 40 of any of the stations 10, based on a predetermined condition; and a mass controller 70, wherein the mass controller 70 is programmed to execute the processes of:

5 (c1) storing a bet area 36 on which a bet is placed and a game value placed as the bet in each station 10, (c2) determining a resulting symbol from the plurality of symbols 21, (c3) rotating the wheel 51 based on an operation of the lever device 40 in one on of the

10 plurality of stations 10, whose lever device 40 has been activated by the lever activating units 109 and 712, and lighting up all the symbols 21 by the symbol LEDs 37; (c4) stopping the wheel 51 being rotated so that the pointer 53 points at the spot 52 with the resulting symbol, and

15 lighting up only the resulting symbol by the corresponding one of symbol LEDs 37; and (c5) awarding a payout based on the resulting symbol 21 and the odds set for the bet area 36 on which the bet is placed in the station 10.

[0025]

20 Further, the gaming machine 1 of the present embodiment includes: a wheel 51 having a plurality of spots 52 in which a plurality of symbols 21 are arranged on the same plane, respectively, the wheel being capable of rotating in such a manner that the symbols 21 are

25 visible; a pointer 53 fixed apart from the rotatable wheel

51, which points one of the spots 52; a plurality of stations 10 (10a, 10b, 10c, 10d, 10e) each having a lever device 40 for starting rotation of the wheel 51, and a display 20 for displaying a plurality of bet areas 36  
5 corresponding to the symbols 21, each station structured to receive a bet of a game value on a bet area 36 and to award a payout based on odds set for the bet area 36; lever activating units 109 and 712 which activate the lever device 40 of any of the stations 10, based on a  
10 predetermined condition; and a rotation count table storage 714 which stores a rotation count table regulating the number of rotations of the wheel 51; and a mass controller 70, wherein the mass controller 70 is programmed to execute the processes of: (d1) storing a bet  
15 area 36 on which a bet is placed and a game value placed as the bet in each station 10, (d2) determining a resulting symbol from the plurality of symbols 21, (d3) rotating the wheel 51 the number of times according to the rotation count table stored in the rotation count table  
20 storage 714, based on an operation of the lever device 40 in one of the stations 10, whose lever device 40 is activated by the lever activating units 109 and 712; (d4) stopping the wheel 51 being rotated so that the pointer 53 points at one of the spots 52 with the resulting symbol 21,  
25 and (d5) awarding a payout based on the resulting symbol

21 and the odds set for the bet area 36 on which the bet is placed in the station 10.

[0026]

Further, the gaming machine 1 of the present embodiment includes: a wheel 51 having a plurality of spots 52 in which a plurality of symbols 21 are arranged on the same plane, respectively, the wheel being capable of rotating in such a manner that the symbols 21 are visible; a pin 54 provided between spots 52 adjacent to each other; a pointer 53 fixed apart from the rotatable wheel 51, which points one of the spots 52; a speaker 59 which outputs a sound effect; a plurality of stations 10 (10a, 10b, 10c, 10d, 10e) each having a lever device 40 for starting rotation of the wheel 51, and a display 20 for displaying a plurality of bet areas 36 corresponding to the symbols 21, each station structured to receive a bet of a game value on a bet area 36 and to award a payout based on odds set for the bet area 36; lever activating units 109 and 712 which activate the lever device 40 of any of the stations 10, based on a predetermined condition; and a mass controller 70, wherein the mass controller 70 is programmed to execute the processes of: (e1) storing a bet area 36 on which a bet is placed and a game value placed as the bet in each station 10, (e2) determining a resulting symbol from the plurality of

symbols 21, (e3) rotating the wheel 51 based on an operation of the lever device 40 in one of the plurality of stations 10, whose lever device 40 has been activated by the lever activating units 109 and 712, (e4) when the pointer 53 passes the pin 54, outputting a sound effect from the speaker 59 based on the rotation angle of the wheel 51, (e5) stopping the wheel 51 being rotated so that the pointer 53 points at one of the spots 52 with the resulting symbol 21, (e5) awarding a payout based on the resulting symbol 21 and the odds set for the bet area 36 on which the bet is placed in the station 10.

[0027]

Further, the gaming machine 1 of the present embodiment includes: a wheel 51 having a plurality of spots 52 in which a plurality of symbols 21 are arranged on the same plane, respectively, the wheel being capable of rotating in such a manner that the symbols 21 are visible; a pointer 53 fixed apart from the rotatable wheel 51, which points one of the spots 52; a pointer LED 55 which lights up the pointer 53; a plurality of stations 10 (10a, 10b, 10c, 10d, 10e) each having a lever device 40 for starting rotation of the wheel 51, and a display 20 for displaying a plurality of bet areas 36 corresponding to the symbols 21, each station structured to receive a bet of a game value on a bet area 36 and to award a payout

based on odds set for the bet area 36; lever activating units 109 and 712 which activate the lever device 40 of any of the stations 10, based on a predetermined condition; and a mass controller 70, wherein the mass controller 70 is programmed to execute the processes of:

5 (f1) storing a bet area 36 on which a bet is placed and a game value placed as the bet in each station 10, (f2) determining a resulting symbol from the plurality of symbols 21, (f3) rotating the wheel 51 and lighting up the pointer 53 by the pointer LED 55, based on an operation of

10 the lever device 40 in one of the plurality of stations 10, whose lever device 40 has been activated by the lever activating units 109 and 712; (b5) stopping the wheel 51 being rotated so that the pointer 53 points at one of the

15 spots 52 with the resulting symbol 21, and (f5) awarding a payout based on the resulting symbol 21 and the odds set for the bet area 36 on which the bet is placed in the station 10.

[0028]

20 Further, the gaming machine 1 of the present embodiment includes: a wheel 51 having a plurality of spots 52 in which a plurality of symbols 21 are arranged on the same plane, respectively, the wheel being capable of rotating in such a manner that the symbols 21 are

25 visible; a plurality of stations 10 (10a, 10b, 10c, 10d,

10e) each of which has a display 20 for displaying a plurality of bet areas 36 corresponding to the symbols 21, and is structured to receive a bet of a game value on a bet area 36 and to award a payout based on odds set for the bet area 36; a mass controller 70 which stores a bet area 36 on which a bet is placed and a game value placed as the bet in each station 10, determines a resulting symbol from the plurality of symbols 21 through the rotation of the wheel 51, and awards a payout based on the resulting symbol 21 and the odds set for the bet area 36 on which the bet is placed in the station 10; wherein the mass controller 70 adjusts the payout rate by varying the odds set for the bet areas 36 in the plurality of stations 10.

15 [0029]

Further, the gaming machine 1 of the present embodiment includes: a wheel 51 having a plurality of spots 52 in which a plurality of symbols 21 are arranged on the same plane, respectively, the wheel being capable of rotating in such a manner that the symbols 21 are visible; a plurality of stations 10 (10a, 10b, 10c, 10d, 10e) each of which has a display 20 for displaying a plurality of bet areas 36 corresponding to the symbols 21, and is structured to receive a bet of a game value on a bet area 36 and to award a payout based on odds set for

the bet area 36; a mass controller 70 which stores a bet area 36 on which a bet is placed and a game value placed as the bet in each station 10, determines a resulting symbol from the plurality of symbols 21 through the rotation of the wheel 51, and awards a payout based on the resulting symbol 21 and the odds set for the bet area 36 on which the bet is placed in the station 10; wherein the payout rate is adjusted by changing the number of symbols 21 arranged in the spots 52.

10 [0030]

Further, the mass controller 70 switches the form of displaying the odds set for the bet areas 36 on the display 20 of the station 10.

[0031]

15 Note that the "operation of the lever device 40" in the present embodiment means pulling the lever device 40 provided to each station 10 towards the player. In the present embodiment, the wheel 51 is rotated by pulling the lever device 40. Note that the operation of the lever device 40 is not limited to pulling of the same towards the player. For example, the operation may be pushing of the lever device 40 in a direction away from the player or pressing of a button.

[0032]

25 Further, the "activating the lever device 40" means



to shift the state of the lever device 40 from the state in which the operation is disabled to the state in which the operation is possible. That is, the lever device 40 cannot be operated while it is inactive, and can be operated when it is active.

[0033]

Note that, in the present embodiment, the "game medium" uses medals; however, a game medium such as bills or the like may be adopted.

10 [0034]

(Function flow of gaming machine)

The following describes functions of the gaming machine 1 of the present embodiment, with reference to FIG. 2. As shown in FIG. 2, the station 10 waits for a bet by a player on a bet area 36 displayed on the display 20. The bet area 36 on which the bet is placed and the bet amount thereon are received by the bet information receiving unit 101 as bet information, and stored in the bet information storage 102 in the form of a bet information managing table shown FIG. 14. The bet information thus stored is transmitted in the form of a bet information signal, from the transmission/reception unit 110 to the transmission/reception unit 710 on the mass controller 70 side. On the mass controller 70 side, the bet information received is stored in the bet

information storage 701 in the form of station managing table shown in FIG. 16. Then, based on the bet information thus stored, a lever operator determination unit 702 executes lever operator determination process.

5 The lever operator determination process is a process for determining which station 10 can rotate the wheel 51 when starting the game. Such a station 10 which can rotate the wheel 51 is determined based on a predetermined condition referring to the bet information; e.g., a station 10

10 through which a greatest amount of bet has been placed among the plurality of the stations 10. When the lever operator determination process is executed by the lever operator determination unit 702, a lever operator signal which causes the lever device 40 to be active is

15 transmitted to a station 10 from the lever activating unit 712 via the transmission/reception unit 710, so as to enable the station 10 to rotate the wheel 51.

[0035]

The lever operator signal having been transmitted

20 from the mass controller 70 side is receive by the lever activating unit 109 on the station 10 side, and the lever device 40 is activated by the lever activating unit 109. Note that, instead of determining a station 10 through which a greatest amount of bet has been entered as the

25 station 10 to rotate the wheel 51, a station 10 to rotate

the wheel 51 can be determine according to a predetermined sequence. Further, the lever activating units 109 and 712 prohibit activation of the lever device 40 in a station 10 if the amount of bet from that station 10 falls short of a predetermined amount of game value. Note that the lever activating units 109 and 712 are provided to the station 10 and the mass controller 70, respectively, in the present embodiment. However, it is possible that one of the station 10 and the mass controller 70 has a lever activating unit. In other words, the lever device 40 may be activated by the lever activating unit 109 of the station in response to the lever operator signal directly received from the lever operator determination unit 702, or activated directly by the lever activating unit 712 of the mass controller 70.

[0036]

In the station 10 whose lever device 40 is activated, the lever device 40 is operated by the player. At this point, the lever speed measurement/determination unit 103 measures an operation period of the lever device 40 having been operated, and determines which one of three speed levels (Slow, Normal, Fast) the measured speed falls under by referring to the lever operation time table shown in FIG. 15. The speed level thus determined is stored in a lever speed information storage 104 and is transmitted as

the lever speed signal from the transmission/reception unit 110 to the mass controller 70. On the mass controller 70 side, a wheel rotation speed random determination unit 703 randomly determines the rotation speed of the wheel 51 based on the lever speed information having been received. For example, when the speed level is determined as to be Slow, referring to the wheel rotation speed table shown in FIG. 17, the wheel rotation speed random determination unit 703 randomly determines one of the 8 rpm and 9 rpm as the initial velocity. Thus, the initial rotation speed of the wheel 51 is determined. After that, the resulting symbol is determined from the plurality of symbols 21 by the resulting symbol random determination unit 715.

15 [0037]

Then, a wheel stop-effect pattern random determination unit 705 determines a stop effect of the wheel 51, referring to the wheel stop-effect pattern table shown in FIG. 18. Through this process, a point position of the pointer 53 pointing the spot 52 with the resulting symbol, i.e., the stop position of the wheel 51 is determined, and the rotation angle of the wheel 51 up to the next stop position is determined. Next, the motion controller 66 is controlled by the wheel rotation speed curve adjusting unit 704, so that the rotation speed curve

of the wheel 51 within a predetermined period is determined based on rotation speed data stored in the rotation speed data storage 713. The rotation speed curve of the wheel 51 is a curve showing the transition of the rotation of the wheel 51 from the start to the stop, in relation to the rotation angle of the wheel 51, as shown in FIG. 21. Thus, the rotation angle of the wheel 51 and the rotation speed in relation to the rotation angle are determined through calculation. Note that, it is a characteristic of the present embodiment that, when the wheel 51 is stopped, the rotation of the wheel 51 is rapidly decelerated (first deceleration period) and then gradually decelerated (second decelerate period), so that the wheel 51 is stopped in a short period.

15 [0038]

After that, the game running unit 708 runs the game by rotating the wheel 51. At this time, the game running unit 708 controls the motor 61 provided to the roulette device 50 so as to rotate the wheel 51 while varying the speed of the rotation. Note that there are cases in which the game running unit 708 stops the wheel 51 after rotating the wheel 51 twice or three times, based on the rotation count table regulating the number of rotations of the wheel 51, the rotation count table being stored in the rotation count table storage 714. Further, a pointer

position determination unit 706 accurately determines whether or not the pointer 53 has passed a pin 54, based on the tilt of the pointer 53 of the roulette device 50 detected by a later mentioned pointer position detection sensor 56. Further, a pin position determination unit 707 accurately determines the rotation angle of the wheel 51, based on the position information of the pin 54 of the roulette device 50 detected by a later mentioned pin position detection sensor 57.

10 [0039]

When rotating the wheel 51, the game running unit 708 controls the symbol LEDs 37 provided in the roulette device 50 to light up all the symbols 21 being rotated. When stopping the wheel 51, the game running unit 708 controls the symbol LEDs 37, so that only the symbol resulted is lighted up. When rotating the wheel 51, the game running unit 708 controls the pointer LED 55 provided to the roulette device 50 to light up the pointer 53 while the wheel 51 is rotating. Further, when rotating the wheel 51, the game running unit 708 causes output of a sound effect from the speaker 59 of the roulette device 50 based on the rotation angle of the wheel 51 when the pointer 53 passes the pin 54 between two adjacent spots 52.

20 [0040]

25 When the resulting symbol is determined in the game

run as described above, result information is transmitted as a result signal to the transmission/reception unit 110 of the station 10. The result information at least contains: information of the symbol 21 having been  
5 resulted; and information on a payout which is determined referring to a payout pattern table shown in FIG. 19, based on the bet information of the bet having been entered from the station 10. Note that FIG. 19 shows payout pattern tables, in each of which the odds is  
10 changed to adjust the payout rates. The payout rate is freely adjustable by selecting a desirable payout pattern table. The payout rate may be adjusted by changing the number of symbols 21 on the wheel 51, instead of changing the odds in the payout pattern table. Next, the an effect  
15 for the result is determined by the resulting number effect determination unit 106, based on the result information received by the transmission/reception unit 110, and the effect for the result is given by using the speaker 18 or a liquid crystal display device 19. Further,  
20 based on the result information, the payout is determined by the payout determination unit 107 and is awarded by the payout unit 108.

[0041]

Note that a bet period measurement unit 711 in the  
25 mass controller 70 measures a bet period which is a period

for receiving a bet from any of the plurality of stations  
10. When the bet period is elapsed, the bet period  
measurement unit 711 transmits a bet period end signal  
from the transmission/reception unit 710 to the stations  
5 10 to end reception of a bet. When a payout display  
changing button 12 of the station 10 is pressed by a  
player, the payout display content changing unit 105  
outputs a signal to change the form of displaying the odds  
set for the bet areas 36. Based on this signal, the form  
10 of displaying on the display 20 of the liquid crystal  
display device 19 is changed.

[0042]

As described, with the gaming machine 1 of the  
present embodiment, the wheel 51 used in the game is  
15 automatically rotated or stopped by controlling the mass  
controller 70. Thus, unlike a simple roulette game,  
various effects can be provided to the game, and the  
entertainment characteristic of the game is improved. The  
wheel 51 used in the game is also rotatable by having the  
20 player operate the lever device 40 provided to the station  
10. Since the game can be started by a hand of the player,  
the player may feel more involved in the game and become  
more enthusiastic about the game. Further, since the  
player of only one station 10 among the plurality of  
25 stations 10 is able to operate the lever device 40, the



player who can operate the lever device 40 feels he/she is more advantaged than the other players. This makes the operation of the lever device 40 very attractive to the players, and as a result, the entertainment characteristic of the game is improved.

[0043]

Further, with the gaming machine 1 of the present embodiment, the player tries to bet more than the others to operate the lever device 40 which rotates the wheel 51. This contributes to heating up the game, and further improves the entertainment characteristic of the game.

[0044]

Further, with the gaming machine 1 of the present embodiment, the right to operate the lever device 40 for rotating the wheel 51 is rotated to each station 10. This contributes to the reduction of the possibility that the player trying to operate the lever device 40 while it is not his/her turn and consequently damaging or deteriorating the lever device 40.

[0045]

Further, with the gaming machine 1 of the present embodiment, the lever device 40 cannot be operated if the amount of bet entered falls short of a predetermined amount of game value. This motivates the player to bet at least the predetermined amount of game value to operate

the lever device 40. As the result, the gaming machine 1 has an improved cost performance. Further, since the player who has not yet bet the predetermined amount of game value is not able to operate the lever device 40, the right for operating the lever device 40 will not be given to a vacant station 10, nor will it be given to the player who not yet participated into the game.

[0046]

Further, with the gaming machine 1 of the present embodiment, the wheel 51 rotates at a rotation speed corresponding to the operation period of the lever device 40 for rotating the wheel 51. Therefore, the rotation speed of the wheel 51 is not the same every time the wheel 51 is rotated. When compared with a gaming machine 1 in which the wheel 51 rotates in the same manner all the time, the above gaming machine 1 provides an improved entertainment characteristic which more likely keeps the enthusiasm of the players to the game, without causing them to get board of the game.

[0047]

Further, with the gaming machine 1 of the present embodiment, the rotation speed of the wheel 51 can be varied by controlling the motor 61 with the mass controller 70. Therefore, for example, the wheel 51 can be rotated at a desirable rotation speed, and stopped at a

desirable position. This enables wider variation of the game, and further improves the entertainment characteristic.

[0048]

5 Further, with the gaming machine 1 of the present embodiment, the rotation speed of the wheel 51 is accelerated and decelerated within a predetermined period. When compared with a gaming machine 1 in which the wheel 51 rotates at a constant speed, the above gaming machine 1  
10 provides an improved entertainment characteristic that more likely keeps the enthusiasm of the players to the game, without causing them to get board of the game.

[0049]

15 Further, with the gaming machine 1 of the present embodiment, the rotating wheel 51 is rapidly decelerated once, and then is gradually decelerated and stopped. Thus, even when a large wheel 51 which generates a large inertia is adopted, the wheel 51 is gradually stopped in a short period. This improves the operation rate of the gaming  
20 machine 1.

[0050]

25 Further, with the gaming machine 1 of the present embodiment, it is possible to provide an effect that all the symbols 21 are lighted up during the rotation of the wheel 51, and when the wheel 51 stops and the resulting

symbol is determined, only the resulting symbol is lighted up. This lighting effect enables the players to feel the excitement of the scene, and further improves the entertainment characteristic of the game.

5 [0051]

Further, with the gaming machine 1 of the present embodiment, it is possible to rotate the wheel 51 a predetermined number of times. Therefore, for example, if the wheel 51 needs to be rotated at least three times according to a national regulation, the wheel 51 is stopped after the rotating at least three times, and if the wheel 51 needs to be rotated at least twice, according to a national regulation, the wheel 51 is stopped after rotating at least twice. As is understood from this, the number of rotations of the wheel 51 is freely adjustable. Therefore, it is possible to speed up the game in some countries.

15 [0052]

Further, with the gaming machine 1 of the present embodiment, a sound effect is output from the speaker 59, based on the rotation angle of the wheel 51 when the pointer 53 passes a pin 54. It is therefore possible to, for example, output a sound effect only when the pointer 53 completely passes the pin 54. This sound effect enables the players to feel the excitement of the scene,

and further improves the entertainment characteristic of the game.

[0053]

Further, with the gaming machine 1 of the present embodiment, the pointer 53 is lighted up during the rotation of the wheel 51. It is therefore possible to provide the player with this light up effect, and the entertainment characteristic of the game is further improved. This light up effect further yields an advantageous effect that people can grasp the progression of the game from a far distance.

[0054]

With the gaming machine 1 of the present embodiment, the wheel 51 used in the game is automatically rotated or stopped by controlling the mass controller 70. Thus, unlike a simple roulette game, various effects can be provided to the game, and the entertainment characteristic of the game is improved. Further, the payout rate is adjustable by changing the odds. Therefore, for example, the gaming machine 1 can be efficiently operated by adjusting the payout rate according to the operation rate of the gaming machine 1.

[0055]

Further, with the gaming machine 1 of the present embodiment, the payout rate is adjustable by changing the

number of symbols 21. Therefore, for example, the gaming machine 1 can be efficiently operated by adjusting the payout rate according to the operation rate of the gaming machine 1.

5 [0056]

Further, with the gaming machine 1 of the present embodiment, the form of displaying the odds on the display 20 of the station 10 is switchable. Therefore, the form of displaying can be adjusted to a form that is easiest to see for the players while playing the game.

[0057]

(Mechanical structure of gaming machine)

Next, the following more specifically describes mechanical structure of the gaming machine 1 of the present embodiment. As shown in FIG. 1, the gaming machine 1 includes: a roulette device 50, a plurality of stations 10(10a, 10b, 10c, 10d, 10e) each having a lever device 40 and a display 20. The plurality of stations 10 are arranged adjacent to one another and in front of the roulette device 50 so that the player playing a game on any station 10 can see the plurality of symbols 21 on the wheel 51 of the roulette device 50.

[0058]

As shown in FIG. 3, the roulette device 50 has a large circular wheel 51 which is supported to be rotatable

about the center thereof. The wheel 51 has a plurality of spots 52 arranged on the same plane along the perimeter of the wheel 51, and each spot 52 has one symbol 21. At a border between two spots 52 adjacent to each other is provided a pin 54. Thus, with the rotation of the wheel 51, the spot 52, the symbol 21, and the pin 54 are rotated. Further, as shown in FIG. 4, on top of the wheel 51 is provided a pointer 53 which is separately fixed from the wheel 51. The pointer 53 has therein an elastic core member 53a, which is surrounded by a light-transmissive resin such as urethane so as to enable the light to pass. Further, pointer 53 is fixed only at the top part thereof, and the lower part is movable to the left and right. When the wheel 51 is rotated, the lower part of the pointer 53 contacts the pins 54 which are rotating with the wheel 51 and moves to the left and right in a manner similar to a pendulum. When the rotation of the wheel 51 stops, the wheel 51 is completely stopped by the contact resistance between the lower part of the pointer 53 and the pins 54. At this time, the lower part of the pointer 53 points at the spot 52 with the resulting symbol 21. Note that the elasticity of the core member 53a of the pointer 53 brings back the pointer 53 to the original position despite the movement of the pointer 53 to the left and right. Further, the plurality of symbols 21 on the wheel 51 can be set by

fitting them from the back side of the wheel 51. Therefore, it is possible to adjust the number of symbols 21. For example, it is possible to increase the number of a certain type of symbols. The symbols 21 on the wheel 51 may be displayed using a liquid crystal display device, and the number of symbols 21 may be adjusted by changing the displaying through the mass controller 70.

[0059]

Further, in the roulette device 50 of the present embodiment, the rotation angle of the wheel 51 between one stop position to the subsequent stop position is randomly determined in advance. The wheel 51 is stopped upon rotating up to the rotation angle determined in advance. Further, in the present embodiment, there has been randomly determined which position of a spot 52 the pointer 53 points when the wheel 51 is stopped. For example, in FIG. 4, each of the spot 52 on the wheel 51 is parted by imaginary lines, into 10 segments: stop positions 1 to 10. Thus, when the wheel 51 is stopped at a predetermined rotation angle, the pointer 53 points any of the stop positions within the spot 52 with the resulting symbol. For example, when the wheel 51 is stopped so that the pointer 53 points at the stop position 10 of the spot 52 with the resulting symbol, the player may have an impression that the pointer 53 almost reached



the symbol 21 next to the resulting symbol but did not make it. Further, for example, when the wheel 51 is stopped so that the pointer 53 points at the stop position 1 of the spot 52 with the resulting symbol, the player may have an impression that the pointer 53 somehow managed to pass the symbol before the resulting symbol 21. In the present embodiment, the pointer 53 is controlled so that the pointer 53 more likely points one of the two ends of the spot 52 (i.e., stop position 1 or stop position 10), when the resulting symbol 21 is a later described "JOKER" or "LOGO" which awards a high payout. This provides an extra thrill to the player, when a high payout is to be awarded.

[0060]

Next, with reference to FIG. 5 and FIG. 6, the following details how the wheel 51 is rotated. As shown in FIG. 5, the pointer 53 has, at its top part, a pointer LED 55 which lights up the pointer 53 while the wheel 51 is rotating. This provides the player with a light up effect of the pointer 53, and improves the entertainment characteristic of the game. This light up effect further yields an advantageous effect that people can grasp the progression of the game from a far distance. On the right side of the pointer 53 is a pointer position detection sensor 56. When the wheel 51 is rotated clockwise, a

laser beam 56a emitted from the pointer position detection sensor 56 is reflected at the center of the pointer 53 and returns to the pointer position detection sensor 56. Based on the period from the point of emitting the laser beam 56a to the point of receiving the returning beam, the pointer position detection sensor 56 detects the tilt angle of the pointer 53. Thus, the mass controller 70 is able to accurately determine whether the pointer 53 has passed a pin 54, based on this information, and is able to accurately control the rotation angle of the wheel 51. Note that the pointer position detection sensor 56 is set obliquely to the wheel 51 so that the rotating wheel 51 or the pins 54 do not disturb the detection using the laser beam 56a. The setting positions and the number of pointer position detection sensors 56 are not limited, and are suitably settable. Further, the means for the pointer position detection sensor 56 to detect the pointer 53 is not limited to a laser beam 56a, and other means may be adopted. On the other hand, on the left side of the wheel 51 is provided a pin position detection sensor 57. The pin position detection sensor 57 is capable of detecting the position of the pin 54 by emitting a laser beam 57a to the wheel 51 and receiving the returning laser beam 57a. For example, the pin position detection sensor 57 detects a pin 54 and detects a subsequent pin 54 with the rotation

of the wheel 51. Based on a period between the detection  
of one pin 54 and detection of the subsequent pin 54, the  
mass controller 70 accurately detects the rotation angle  
of the wheel 51. This way, the mass controller 70 is able  
5 to accurately control the rotation angle of the rotating  
wheel 51. Note that the setting positions and the number  
of the pin position detection sensors 57 are not limited  
and are suitably settable. Further, the means for the pin  
position detection sensor 57 to detect the pin 54 is not  
10 limited to a laser beam 57a, and other means may be  
adopted.

[0061]

As shown in FIG. 5, when the wheel 51 rotates  
clockwise, a laser beam 56a is emitted from the pointer  
15 position detection sensor 56, and detection of the  
position of the pointer 53 is started. At the same time,  
a laser beam 57a is emitted from the pin position  
detection sensor 57 and detection of the position of the  
pin 54 is started. (see FIG. 5A). While the wheel 51 is  
20 rotating, the symbols 21 are lighted up by the symbol LEDs  
37. This lighting effect of the symbols 21 enables the  
players to feel the excitement of the scene, and further  
improves the entertainment characteristic of the game.

[0062]

25 When the wheel 51 continues to rotate, the pointer

53 eventually contacts a pin 54 (see FIG. 5B ). Then, the pin 54 pushes only the lower part of the pointer 53 which is moveable to the left and right, with the rotation of the wheel 51. This tilts the pointer 53 (see FIG. 5C).  
5 When the wheel 51 further rotates, the pointer 53 is further tilted (see FIG. 6D). Eventually, at the moment where the pointer 53 passes the pin 54 with the rotation of the wheel 51, a sound effect is output from the speaker 59 of the roulette device 50 (see FIG. 6E). Note that the  
10 timing of outputting the sound effect from the speaker 59 is based on the rotation angle of the wheel 51 when the pointer 53 passes the pin 54. In other words, in the present embodiment, the rotation angle of the wheel 51 is determined based on the stop position of the wheel 51  
15 before the rotation and the stop position within the spot 52 with the resulting symbol. However, the rotation angle of the wheel 51 for the pointer 53 to pass each of the pins 54 is also determined through calculation. Every time the wheel 51 reaches the calculated rotation angle, a  
20 sound effect is output from the speaker 59. There are two volume levels for the sound effect output from the speaker 59 which are set so that the sound effect to be output before the wheel 51 stops is output at a higher volume level. The number of volume levels of the sound effect to  
25 be output from the speaker 59 is not limited to two levels,

and is suitably settable. As described, a sound effect is output from the speaker 59, based on the rotation angle of the wheel 51 when the pointer 53 passes a pin 54. It is therefore possible to, for example, output a sound effect  
5 only when the pointer 53 completely passes the pin 54. This sound effect enables the players to feel the excitement of the scene, and further improves the entertainment characteristic of the game. Further, since the volume level of the sound effect from the speaker 59  
10 is varied according to the state of the rotation of the wheel 51, the sound effect causes the players to feel more excitement of the scene.

[0063]

Next, if the resulting symbol 21 is "12", the  
15 rotation of the wheel 51 is stopped so that the pointer 53 points a predetermined stop position of the spot 52 with the symbol 21 of "12" (see FIG. 6F). Note that, when the rotation of the wheel 51 is completely stopped and when the pointer 53 points at the resulting symbol, the  
20 resulting symbol which is the symbol 21 of "12" is further lighted up, and while the lighting of the other symbols 21 is shut down.

[0064]

Further, the pointer position detection sensor 56  
25 transmits an error signal to the mass controller 70, when

the pointer 53 is kept tilted for a predetermined period after the wheel 51 is stopped. Then, through the mass controller 70, an error message is displayed on a not-shown display unit provided to the roulette device 50.

5 Note that an alarm sound may be output from the speaker 59, in addition to the error message displayed on the display unit.

[0065]

Further, in the present embodiment, a sound effect  
10 is output from the speaker 59 based on the predetermined rotation angle of the wheel 51; however, the method shown in FIG. 7 is also possible. For example, the roulette device 50 may have means for detecting an angle between the pointer 53 in a state in which the wheel 51 is stopped  
15 and the pointer 53 is vertical (see FIG. 7A) and the pointer 53 which is tilted by the clockwise rotation of the wheel 51 (see FIG. 7B). Then, the pointer 53 may be determined as to have passed the pin 54, when the angle of the pointer 53 with respect to the vertical direction  
20 exceeds a predetermined angle  $\alpha$  (see FIG. 7C), and a sound effect may be then output from the speaker 59.

[0066]

Next, the following describes the lever device 40 of the station 10 with reference to FIG. 8. The lever device  
25 40 has a player-operable lever 41, a cabinet 42 supporting

the lever 41, a lever moving part 44 which makes the lever 41 movable, a start point sensor 45, a midpoint sensor 46, and an end point sensor 47.

[0067]

5           The lever 41 projects from a groove 43 of the cabinet 42 and is movable along the groove. Further, the lower end portion of the lever 41 is connected to the lever moving part 44 which controls the movement of the lever 41. The lever moving part 44 has a projection 48  
10           which is moved with the movement of the lever 41. For example, when the lever 41 is not moved (on the right side of the figure), the projection 48 abuts the start point sensor. When the lever 41 moves to approximately the middle of the groove 43, the projection 48 abuts the  
15           midpoint sensor 46. When the lever 41 moves to the end (on the left side of the figure), the projection 48 abuts the end point sensor 47. As described, when the player operates the lever device 40 to move the lever 41, the projection 48 moves between the start point sensor 45 and  
20           the end point sensor 47.

[0068]

          The start point sensor 45 senses an operation of the lever device 40, when the projection 48 separates from the start point sensor 45. The midpoint sensor 46 senses the  
25           time point where the projection 48 abuts thereto. Then,

the station controller 100 measures the time taken for the projection 48 to move from the start point sensor 45 to the midpoint sensor 46. This measured time is used for determining the rotation speed of the wheel 51. The end point sensor 47 senses abutting of the projection 48 thereto. Note that, if the projection 48 is abutted to the end point sensor 47 for a predetermined period, an alarm is output from the speaker 18. In this case, the wheel 51 does not start rotating, until the player puts back the lever 41. It is possible to adopt a structure in which the station controller 100 controls the lever moving part 44 to automatically bring back the lever 41 to the original state, if the projection 48 is abutted to the end point sensor 47 for a predetermined period. Note that the reason for determining the operation period of the lever device 40 by the operation of the lever device 40 from the start point sensor 45 to the midpoint sensor 46 is that, if the operation period is determined at the end point sensor 47, the player may operate the lever 41 up to the end point sensor 47 with a great force. If the player pulls the lever 41 to the end point sensor 47, the lever 41 may hit the end portion of the groove 43 with a great force thus damaging the lever device 40. In the present embodiment, the operation period is determined at the midpoint sensor 46. Therefore, the force of operating the



lever 41 from the midpoint sensor to the end point sensor is restrained.

[0069]

(Display mode of display of station)

5 Next, the following describes a display mode of the display 20 provided to the station 10, with reference to FIG. 9. On the front surface of the display 20 is pasted a touch panel 35. Pressing the surface of the touch panel 35 by a finger or the like will operate various buttons.

10 [0070]

At the center of the display 20 is displayed a bet screen 22. The bet screen 22 displays bet areas 36 which correspond to the plurality of symbols 21 on the wheel 51, respectively. In the present embodiment, the bet areas 36 with the marks of "1", "3", "6", "12", "25", "JOKER", and "LOGO" are displayed. Further, each of the bet areas 36 has an odds display area 33. For example, in the present embodiment, a bet area 36 corresponding to the symbol of "1" displays its odds of "1", and a bet area 36 corresponding to the symbol of "JOKER" displays its odds of "52". The wording "odds" means the probability of winning the game. The smaller number means a higher possibility of winning the game. Further, the odds also relates to the payout awarded for a game value placed as the bet. For example, when one medal is bet on a symbol

15

20

25

"3" whose odds is "3", the player will gain three medals and have four metals all together, if the player wins the game. The amount paid out will be a quadruple of the bet amount. Further, if one medal is bet on a symbol of "JOKER" whose odds is "52", the player will gain 52 medals and will have all together 53 medals if the player wins the game. That is, 53 times of the amount bet will be paid out. Further, in the bet area 36, a popup image 33a indicating the amount of payout in case of winning the game is displayed. The popup image 33a is displayed at the bet area 36 on which a bet is place, when the player places his/her bet. For example, in the case shown in FIG. 9, five medals are bet on a symbol of "6" whose odds is "6". If the player wins the game, 30 medals are gained. In total, 35 metals, i.e., a seven times of the amount bet, are paid out as a credit. This is notified by the popup image 33a. Thus, the player is able to instantly confirm the amount of payout he/she will get upon winning.

[0071]

Further, below the bet screen 22 are displayed unit bet buttons 32, an acceptable bet amount display area 31, selection buttons 34, a country setting button 30, a rule button 29, and a lever operator notification area 38.

[0072]

Each of the unit bet button 32 displays the number

of medals as a unit to be bet. By dragging to a bet area 36 any of the unit bet buttons 32 while referring to the number shown thereon, the player is able to bet a desirable number of medals on a desirable bet area 36.

5 For example, when the player wishes to bet 35 medals, the player simply has to drag the unit bet button 32 displaying "25" to the bet area 36, and further drag the unit bet button 32 displaying "10" to the same bet area 36. Alternatively, the player may drag seven times the button  
10 showing "5" to the bet area 36.

[0073]

The acceptable bet amount display area 31 displays the minimum and maximum numbers of medals which can be placed as a bet in each game. The selection buttons 34  
15 are buttons for executing various functions. The "REPEAT BET" is a button for placing the same bet placed in the previous game. The "DOUBLE BET" is a button for doubling the number of medals already placed as a bet. "ALL CANCEL" is a button for canceling the bet of medals. The  
20 country setting button 30 is a button for changing the language displayed on the display to the language of the set country, and for changing the currency unit being displayed. The rule button 29 is a button for displaying a guidance of the game. The lever operator notification  
25 area 38 is displayed only when the lever device 40 of the

station 10 is activated so as to notify the player that the player is able to operate the lever device 40.

[0074]

5 Above the bet screen 22 are displayed a gaming result display area 23, a bet timer display area 24, a payout amount display area 25, a bet amount display area 26, a currency display area 27, and a credit amount display area 28. The gaming result display area 23 displays the results of the past games. The bet timer display area 24 displays the time for accepting the bet for the next game. The payout amount display area 25 displays the amount of payout awarded to the player in the previous games. The bet amount display area 26 displays an amount of bet entered for a game. The currency display area 27 displays the currency unit. The credit amount display area 28 displays the current credit amount owned by the player. This credit amount is reduced according to the bet amount, and increases according the amount of payout when there is a payout.

20 [0075]

In the present embodiment, the form of displaying the odds on in the odds display area 33 is changed, by pressing the payout display changing button 12 provided to the station 10. For example, as shown in FIG. 10, the odds displayed in the odds display area 33 may be changed

to the form of displaying using "to". In other words, when the odds is "3", "3 to 1" is displayed. When the odds is "6", "6 to 1" is displayed. When the odds is "52", "52 to 1" is displayed. For example, when one medal is bet on a symbol of "3" whose odds is "3 to 1", the player will gain three medals and will have in total four medals in total, upon winning. Further, when one medal is bet on a symbol of "JOKER" whose odds is "52 to 1", the player will gain 52 medals and will have 53 medals in total upon winning. As described, the form of displaying the odds on the display 20 of the station 10 is switchable. Therefore, the form of displaying can be adjusted to a form that is easiest to see for the players while playing the game.

[0076]

(Internal structure of gaming machine)

Next the following describes an internal structure of the gaming machine 1 of the present embodiment. As shown in FIG. 11, the gaming machine 1 has the roulette device 50, the mass controller 70, and the plurality of stations 10 (10a, 10b, 10c, 10d, 10e). The roulette device 50 and the mass controller 70 are connected to each other and are in communication with via a LAN 68 and USB 67. The plurality of stations 10 are connected to and in communication with the mass controller 70 via the LAN 69 and the HUB 11.

[0077]

The roulette device 50 has a door switch 62 and a door LED 63, and is connected to the mass controller 70 via the interface substrate 64 and the USB 67. Through the control performed by the mass controller 70, the door switch 62 is unlocked, and the door LED 63 is turned on and off.

[0078]

Further, the roulette device 50 has the motion controller 66, a servo pack 65, the motor 61, the pointer position detection sensor 56, and the pin position detection sensor 57. The motion controller 66 determines the rotation speed of the wheel 51, under the control of the mass controller 70, and controls the servo pack 65 to drive the motor 61. Specifically, the motion controller 66 controls the rotation of the wheel 51, by calculating and determining a later-mentioned speed curve of the wheel 51 shown in FIG. 20 which includes an acceleration period, a constant speed period, a first deceleration period, a second decelerate period, based on the maximum rotation speed of the wheel 51 determined by the mass controller 70 and the rotation angle to the winning position. The motor 61 is connected to the wheel 51, and is driven to rotate the wheel 51. By changing the rotation count of the motor 61, the rotation speed of the wheel 51 is varied. By

changing the rotation direction of the motor 61, the rotation direction of the wheel 51 is changed. The pointer position detection sensor 56 detects the period between the emission of the laser beam 56a to the pointer 53 of the wheel 51 and the point when the laser beam 56a returns. The detected information is transmitted to the mass controller 70 via the motion controller 66, to determine the tilt of the pointer 53. The pin position detection sensor 57 emits a laser beam 57a to the pin 54 of the wheel 51 to detect the position of the pin 54. The detected information is transmitted to the mass controller 70 via the motion controller 66 to determine the rotation angle or the like of the wheel 51.

[0079]

Further, the roulette device 50 has the pointer LED 55, the symbol LEDs 37, and a speaker 59. The pointer LED 55 lights up the pointer 53, under the control of the mass controller 70. The symbol LED 37 lights up the symbols 21, under the control of the mass controller 70. The speaker 59 outputs a sound effect, under the control of the mass controller 70.

[0080]

As shown in FIG. 12, the mass controller 70 has a server control CPU 75, a server ROM 71, a server RAM 72, and a timer 73. The server control CPU 75 has at least

the functions of the lever operator determination unit 702 of FIG. 2, the wheel rotation speed random determination unit 703, the resulting symbol random determination unit 715, the wheel rotation speed curve adjusting unit 704, the wheel stop-effect pattern random determination unit 705, the game running unit 708, the pin position determination unit 707, the pointer position determination unit 706, a winning determination unit 709, and lever activating unit 712. The server ROM 71 stores programs of various functions to be executed by the server control CPU. The server RAM 72 has at least the functions of the bet information storage 701 of FIG. 2, the rotation speed data storage 713, and the rotation count table storage 714, and stores a station managing table of FIG. 16, a wheel rotation speed table of FIG. 17, a wheel stop-effect pattern table of FIG. 18, a payout pattern table of FIG. 19, rotation speed data, or the like. The timer 73 has a function of the bet period measurement unit 711 of FIG. 2, and measures the bet period of each station 10.

20 [0081]

As shown in FIG. 13, the station 10 has the station controller 100, the liquid crystal display device 19, the payout display changing button 12, a payout button 14, a hopper 15, a medal sensor 16, the lever device 40, and the speaker 18.

25



[0082]

The station controller 100 has a station control CPU 115, a station ROM 111, and a station RAM 112. The station control CPU 115 has at least the functions of the bet information receiving unit 101 of FIG. 2, the lever activating unit 109, the lever speed measurement/determination unit 103, the payout determination unit 107, the resulting number effect determination unit 106, and the payout display content changing unit 105. The station ROM 111 stores programs of various functions to be executed by the station control CPU 115. The station RAM 112 has at least the functions of the bet information storage 102 of FIG. 2, and the lever speed information storage 104, and stores bet information managing table of FIG. 14 and the lever operation time table of FIG. 15.

[0083]

The liquid crystal display device 19 is connected to the station control CPU 115 via a liquid crystal driving circuit 17, and displays an image under control of the station control CPU 115. Further, the liquid crystal display device 19 has the display 20, and the display 20 has on its front surface the touch panel 35. The information of operating the touch panel 35 is processed by the station control CPU 115.

[0084]

The payout display changing button 12 is a button which changes the form of displaying the odds displayed in the odds display area 33 on the display 20, when pressed by the player. The payout button 14 is a button for paying out the game medium such as medals, when pressed by the player. The hopper 15 pays out, from a payout port, a predetermined number of medals, under control of the station control CPU 115. The medal sensor 16 detects the medals input from the medal insertion slot, and calculates the medals input. The result of calculation is transmitted to the station control CPU 115. The lever device 40 is a device which rotates the wheel 51 upon operation by the player. The speaker 18 outputs a sound effect related to the game under control by the station control CPU 115.

[0085]

(Bet information managing table)

Next, the following describes a bet information managing table provided to the station 10 of the present embodiment, with reference to FIG. 14. The bet information managing table is stored in the station RAM 112 and stores therein the bet information of a bet entered by the player. The bet information managing table has a bet type column and a bet amount column, and a bet

amount is stored for each bet type. The table also stores, for each bet type, a total bet amount which is a total of the bet amounts. Note that bet type correspond to the type of bet area 36 displayed 20, which corresponds to the symbol 21. That is, as the bet type, there are "1", "3", "6", "12", "25", "JOKER", and "LOGO". For example, in cases of FIG. 14, a bet amount "5" is stored in the row of bet type "1" , a bet amount "25" is stored in the row of bet type "3", and a bet amount "10" is stored in the row of bet type "JOKER". Then, in the row of total bet amount, a bet amount "40" which is the total of all the bet amounts is stored. As described, the bet information on a game is managed for each station 10.

[0086]

(Lever operation time table)

Next, the following describes a lever operation time table provided to the station 10 of the present embodiment, with reference to FIG. 15. The lever operation time table includes a lever operation period column and a speed level column. The lever operation period column stores an operation period of the lever device 40. In other words, the lever operation period column stores therein the time taken for the projection 48 to move from the start point sensor 45 to the midpoint sensor 46, when the lever 41 of the lever device 40 is operated. The speed level column

on the other hand stores a speed level corresponding to the lever operation period. For example, in the case of FIG. 15, the speed level "Slow" is stored for the lever operation period "- 5 msec". Similarly, the speed level "Normal" is stored for the lever operation period "6 - 9 msec". The speed level "Fast" is stored for the lever operation period "10 msec -". Note that the speed levels for the lever operation period are not limited to those described above, and are suitably settable.

10 [0087]

(Station managing table)

Next, the following describes a station managing table provided in the mass controller 70 of the present embodiment, with reference to FIG. 16. The station managing table includes a station column, a bet type column, a total bet amount column, and a lever operator column. The station column stores therein the names of the stations 10 (10a, 10b, 10c, 10d, 10e) connected to the mass controller 70. The bet type column stores, for each bet type, a bet amount received from each station 10. The total bet amount column stores the total value of the bet amount received from each station 10. The lever operator column stores information indicating whether the lever device 40 is active or inactive. For example the bet information stored in the bet information managing table

of FIG. 14 is stored, in the row of station a in FIG. 16. As described, the station managing table collectively stores the bet information stored in the bet information managing table of each station 10. In the row of station  
5 c whose total bet amount is "55", a flag"1" is stored in the lever operator column. The station 10 with the flag"1" in its lever operator column has its the lever device 40 activated. On the other hand, the lever devices  
10 40 of the other stations 10 whose lever operator columns stores a flag"0" are inactive. As described, the lever device 40 of the station 10 through which the largest amount of bet is placed is activated. This motivates the player to bet more than the others to win the right to operate the lever device 40 for rotating the wheel. This  
15 contributes to heating up the game, and further improves the entertainment characteristic of the game.

[0088]

As the condition for having the flag "1" stored in the lever operator column, a predetermined sequence may be  
20 determined, and the flag "1" may be stored in the lever operator column of each station 10 according to the predetermined sequence. With this, the right to operate the lever device 40 for rotating the wheel 51 is rotated to each station 10. This contributes to the reduction of  
25 the possibility that the player trying to operate the

lever device 40 while it is not his/her turn and consequently damaging or deteriorating the lever device 40.

[0089]

5           Additionally, the conditions for storing the flag"1" in the lever operator column may include a condition that the flag "1" will not be stored in the lever operator column of a station 10 whose bet amount falls short of a predetermined amount. With this, the lever device 40 cannot be operated if the amount of bet entered falls  
10           short of a predetermined amount of game value. This motivates the player to bet at least the predetermined amount of game value to operate the lever device 40. As the result, the gaming machine 1 has an improved cost performance. Further, since the player who has not yet  
15           bet the predetermined amount of game value is not able to operate the lever device 40, the right for operating the lever device 40 will not be given to a vacant station 10, nor will it be given to the player who not yet participated into the game.

20           [0090]

(Wheel rotation speed table)

          Next, the following describes a wheel rotation speed table provided in the mass controller 70 of the present embodiment, with reference to FIG. 17. The wheel rotation  
25           speed table includes a speed level column and an initial

rotation speed column. The speed level column stores the same information as the information of the speed level column in the lever operation time table of FIG. 15. The initial rotation speed column stores an initial rotation speed of the wheel 51 for each speed level. For example, in case of FIG. 17, two initial rotation speeds "8 rpm" and "9 rpm" are stored for the speed level of "Slow". Further, initial rotation speeds "10 rpm" and "11 rpm" are stored in the speed level of the "Normal". The initial rotation speeds "12 rpm" and "13 rpm" are stored in the speed level of "Fast". These pieces of information are used for randomly determining the initial rotation speed of the wheel 51 for the operation period of the lever device 40 having been operated at the station 10. Note that the initial rotation speeds for the above mentioned speed levels are not limited to those, and are suitably settable.

[0091]

As described, the wheel 51 rotates at a rotation speed corresponding to the operation period of the lever device 40 for rotating the wheel 51. Therefore, the rotation speed of the wheel 51 is not the same every time the wheel 51 is rotated. When compared with a gaming machine 1 in which the wheel 51 rotates in the same manner all the time, the above gaming machine 1 provides an

improved entertainment characteristic which more likely keeps the enthusiasm of the players to the game, without causing them to get board of the game.

[0092]

5 (Wheel stop-effect pattern table)

Next, the following describes the wheel stop-effect pattern table provided to the mass controller 70 of the present embodiment, with reference to FIG. 18. The wheel stop-effect pattern table includes a stop position column and a wheel-stop determination column. The stop position column stores the ten stop positions from "1" to "10". In other words, as shown in FIG. 4, the stop position column stores the ten stop positions of the spot 52 with the resulting symbol. The wheel-stop determination column stores a flag indicating "1" or " 0". When the flag in the wheel-stop determination column indicates " 1", the rotation of the wheel 51 is stopped so that the pointer 53 points at the stop position with the flag indicating "1". Whether or not the flag indicating "1" is stored in the wheel-stop determination column is randomly determined by the mass controller 70. For example, in the case of FIG. 18, the flag"1" is stored in the wheel-stop determination column of the stop position "10". In this case, there is provided an effect which makes it look as if the pointer 53 will reach the symbol 21 subsequent to the resulting

10  
15  
20  
25



symbol. The number of stop positions is not limited to ten, and is suitably settable.

[0093]

(Payout pattern table)

5           Next, the following describes a payout pattern table provided in the mass controller 70 of the present embodiment, with reference to FIG. 19. The payout pattern table includes a symbol column, a spot number column, a probability column, an odds column, a payout rate column.

10           The symbol column stores the names of various symbols. The spot number column stores, for each type of symbols 21, the number of spots on the wheel 51 with the symbol 21. The probability column stores the probability of having the corresponding symbol selected as a resulting symbol

15           through a random determination. The odds column stores the odds for each symbol 21. The payout rate column stores a payout rate for each symbol 21. The payout rate is an amount of payout awarded for the amount invested by a player, which is expressed in a percentage. Higher the

20           payout rate, the higher the amount of the payout to the player, which is more advantageous to the player. In the present embodiment, there are three types of payout pattern tables: type A to type C. The payout rates in these tables are changed by changing the odds. For

25           example, in type A of FIG. 19A, the odds for the symbols

of "JOKER" and "LOGO" are "53", and the total payout rate is 96.032%. On the other hand in type B of FIG. 19B, for example, the odds for the symbols of "JOKER" and "LOGO" are "52", and the total payout rate is 95.503%. As is understood from this, the total payout rate is smaller in type B than type A. As described, the payout rate is suitably settable from the highest rate of 96.032% in the payout pattern table of type A to the lowest rate of 94.974% in the payout pattern table of type C, by changing the odds for the symbols 21. These payout pattern tables may be set by an operator or changed and set as needed by the mass controller 70 every time the game is run a predetermined number of times. In the present embodiment, the payout rate is adjusted by changing the odds for "JOKER" and "LOGO". The payout rate may be adjusted by changing the odds for the other symbols 21. As described, the payout rate is adjustable by changing the odds. For example, by adjusting the payout rate according to the operation rate of the gaming machine 1, the operation rate could be effectively improved..

[0094]

Further, in the present embodiment, the payout rate is changed by changing the odds as in the case of the payout pattern table of FIG. 19. The payout rate however may be changed by changing the number of symbols 21. For

example, in the present embodiment, the number of symbols "1" is 26, the number of symbols "3" is 13, the number of symbols "6" is 7, and the number of symbols "12" is 4, the number of symbols "25" is 2, and the number of symbols "JOKER" is 1 and the number of "LOGO" is 1. Although these numbers are fixed, the payout rate may be adjusted by changing these numbers. As described, with the gaming machine 1 of the present embodiment, the payout rate is adjustable by changing the number of symbols 21. For example, by adjusting the payout rate according to the operation rate of the gaming machine 1, the operation rate could be effectively improved..

[0095]

(Exemplary rotation speed curve)

Next, the following describes, with reference to FIG. 20, an exemplary rotation speed curve of the wheel 51 which is determined by the motion controller 66 under control of the mass controller 70 of the present embodiment. In FIG. 20 showing the rotation speed curve, the horizontal axis represents the rotation angle of the wheel 51, while the vertical axis represents the rotation speed of the wheel 51. The rotation angle of the wheel 51 means an angle by which the wheel 51 rotates. When the wheel 51 makes one rotation, the rotation angle is 360. As shown in FIG. 21, when the wheel 51 of the present

embodiment starts rotating, the rotation of the wheel 51 reaches the maximum speed B in 1 msec of an acceleration period. The initial rotation speed during the acceleration period is a speed corresponding to the operation period of the lever device 40 of the station 10 which is determined from the plurality of the stations 10 based on the bet information or the like. In short, the initial rotation speed is a speed determined by referring to the wheel rotation speed table of FIG. 17 or the like. Since the time (1 msec) to reach the maximum speed B = S-shaped control time (set to 500 msec) + acceleration time, the acceleration C in the acceleration period is as shown in the following (Equation 1).

[0096]

(Equation 1)

$$C = B * 2$$

where C is the acceleration in the acceleration period, B is the maximum speed.

[0097]

Note that the maximum speed B = 8 rpm to 13 rpm. This maximum speed is set in consideration of the initial rotation speed. The rotation of the wheel 51 having reached the maximum speed B enters the constant speed period of 1 msec, and then transits to the first deceleration period to be rapidly decelerated. Note that

the rotation angle D by which the wheel 51 rotates in the acceleration period and the constant speed period is found by the following (Equation 2) using the formula for linear motion of acceleration.

5 [0098]

(Equation 2)

$$D = 1/2 * C + B$$

where D is the rotation angle in the acceleration period and the constant speed period, C is acceleration in the acceleration period, and B is the maximum speed.

10 [0099]

The first deceleration period is a period in which the wheel 51 is rapidly decelerated when there is only a half round left before reaching the stop position. The rotation angle Y by which the wheel 51 rotates during this period is found by the following (Equation 3) using the formula for linear motion of acceleration.

15 [0100]

(Equation 3)

20  $Y = A - D$  - the distance of a half round

where A is the rotation angle from the start of the rotation of the wheel 51 to the point where the wheel 51 stops, D is a rotation angle in the acceleration period and the constant speed period, and Y is the rotation angle of the first deceleration period.

[0101]

The deceleration 1 in the first deceleration period is found by the following (Equation 4) using the formula for linear motion of acceleration.

5 [0102]

(Equation 4)

$$\text{Deceleration 1} = (X^2 - B^2) / (2 * Y)$$

where X is the rotation speed at the end of the first deceleration period, B is the maximum speed, and Y is the rotation angle in the first deceleration period.

10 [0103]

When the first deceleration period ends, the rotation of the wheel 51 enters the second decelerate period during the remaining half round. The wheel 51 is decelerated more gradually than the deceleration 1 in the first deceleration period, and then stopped at a predetermined stop position. The deceleration 2 in the second decelerate period is found by the following (Equation 5) using the formula for linear motion of acceleration.

20 [0104]

(Equation 5)

$$\text{Deceleration 2} = X^2 / (2 * 360 * 3)$$

where X is the rotation speed at the end of the first deceleration period.

[0105]

The above equation is calculated by a formula for linear motion of acceleration shown in the following (Equation 6).

5 [0106]

(Equation 6)

$$v = v_0 + a * t$$

$$s = v_0 * t + (1/2) * a * t^2$$

$$v^2 - v_0^2 = 2 * a * s$$

10 where v is the velocity,  $v_0$  is the initial velocity, a is the acceleration, t is the time, and s is the distance.

[0107]

The rotation speed of the wheel 51 is controlled and  
15 adjusted by the mass controller 70 as described hereinabove. Thus, the rotation speed of the wheel 51 is accelerated and decelerated within a predetermined period. Therefore, when compared with a gaming machine 1 in which the wheel 51 rotates at a constant speed, the above gaming  
20 machine 1 provides an improved entertainment characteristic that more likely keeps the enthusiasm of the players to the game, without causing them to get board of the game. Further, the rotating wheel 51 is rapidly decelerated once, and then is gradually decelerated and  
25 stopped. Thus, even when a large wheel 51 which generates

a large inertia is adopted, the wheel 51 is gradually stopped in a short period. This improves the operation rate of the gaming machine 1.

[0108]

5           The number of rotations of the wheel 51 can be set in advance. For example, the wheel 51 is stopped after rotating at least the number of times provided by each nation; stopping after rotating at least two times, or the like. Further, it is possible to rotate the wheel 51 a  
10           predetermined number of times. Therefore, for example, if the wheel 51 needs to be rotated at least three times according to a national regulation, the wheel 51 is stopped after the rotating at least three times, and if  
15           the wheel 51 needs to be rotated at least twice, according to a national regulation, the wheel 51 is stopped after rotating at least twice. As is understood from this, the number of rotations of the wheel 51 is freely adjustable. Therefore, it is possible to speed up the game in some countries.

20           [0109]

(Station side game process)

          Next, the following describes a station side game process executed in the station controller 100, with reference to FIG. 21. As shown in FIG. 21, first the  
25           station controller 100 determines whether or not a game



medium such as a medal has been input from the medal  
insertion slot or the like of the station 10 (S11). When  
it is determined that no medal has been input, the station  
controller 100 waits for an input of a medal. On the  
5 other hand, if it is determined that a medal has been  
input, the station controller 100 adds the amount of  
credit corresponding to the medal (S12). Then, the  
station controller 100 transmits to the mass controller 70  
a medal detection signal indicating an input of a medal  
10 (S13).

[0110]

Then, the station controller 100 displays a bet  
screen 22 as shown in FIG. 9 on a display 20 of the  
station 10, and displays a bet time for accepting player's  
15 bet in the bet timer display area 24 (S14). The station  
controller 100 then executes a bet operation receiving  
process for receiving a bet operation from the player  
(S15). Thus, the player participating in the game is able  
to place a bet during the bet time for accepting the bet.  
20 When a bet from the player is received, the station  
controller 100 transmits, to the mass controller 70, bet  
information related to the bet area 36 on which the bet is  
placed and the bet amount placed thereon as the bet  
information signal (S16). After that, the station  
25 controller 100 determines whether or not a bet period end

signal notifying the end of the bet period is received from the mass controller 70 (S17). When it is determined that no bet period end signal is received, the station controller 100 waits for a bet operation by the player.

5 On the other hand, if it is determined that the bet period end signal has been received, the station controller 100 sets the bet time displayed in the bet timer display area 24 to zero, and ends the reception of a bet operation by the player.

10 [0111]

Next, the station controller 100 determines whether or not a lever operator signal has been received from the mass controller 70 (S19). When it is determined that no lever operator signal is received from the mass controller  
15 70, the station controller 100 shifts the process to S23. On the other hand, if it is determined that the lever operator signal is received, the station controller 100 unlocks the lever device 40. That is, the lever device 40 is activated (S20). After that, the station controller  
20 100 determines whether or not the player has operated the lever device 40 (S21). When it is determined that the lever device 40 has not been operated, the station controller 100 waits for the operation of the lever device 40. On the other hand, when it is determined that the  
25 player has operated the lever device 40, the station

controller 100 measures the operation period of the lever device 40. That is, the station controller 100 measures the time taken for the projection 48 of the lever device 40 to move from the start point sensor 45 to the midpoint sensor 46, when the lever device 40 is operated by the player. Then, based on the operation period measured, the station controller 100 determines the speed level referring to the lever operation time table of FIG. 15, and transmits the lever speed signal including information related to the speed level to the mass controller 70 (S22).

[0112]

After that, the station controller 100 determines whether or not a result signal including information related to the result is received from the mass controller 70 (S23). When it is determined that no result signal is received from the mass controller 70, the station controller 100 waits for the result signal. On the other hand, when it is determined that the result signal is received, the station controller 100 determines an effect for notifying the resulting number or the like based on the result information included in the result signal, and notifies the resulting number or the like to the player through the liquid crystal display device 19 and the speaker 18 (S24). Then, the station controller 100 pays out the credit based on the result information (S25),

waits for the end of the unit game (S26). Then, when a unit game end signal is received from the mass controller 70, this routine is ended.

[0113]

5 (Mass Controller side game process)

Next, the following describes a mass controller side game process executed in the mass controller 70, with reference to FIG. 22. As shown in FIG. 22, first, the mass controller 70 determines whether or not a medal  
10 detection signal is received from any of the stations 10 (10a, 10b, 10c, 10d, 10e) (S51). When it is determined that no medal detection signal is received, the mass controller 70 waits for reception of the medal detection signal. On the other hand, when it is determined that the  
15 medal detection signal is received, the mass controller 70 starts measurement of the bet period (S52).

[0114]

Next, the mass controller 70 executes the bet information signal reception process for receiving a bet  
20 information signal from the station 10 (S53). Then, the mass controller 70 stores the bet information in the station managing table of FIG. 16 based on the bet information signal received (S54). After that, the mass controller 70 determines whether or not the bet period has  
25 ended (S55). When it is determined that the bet period is

not ended, the mass controller 70 executes again the bet information signal reception process. On the other hand, when it is determined that the bet period is ended, the mass controller 70 transmits a bet period end signal to the station 10 (S56).

[0115]

Next, the mass controller 70 executes the lever operator determination process (S57). Through the process, the mass controller 70 determines the station 10 to be the lever operator, referring to the bet information stored in the station managing table of FIG. 16. Then, the mass controller 70 transmits the lever operator signal to the station 10 to be the lever operator (S58).

[0116]

Next, the mass controller 70 determines whether or not a lever speed signal is received (S59). When it is determined that no lever speed signal is received, the mass controller 70 waits for the lever speed signal. On the other hand, when the it is determined that the lever speed signal is received, the mass controller 70 executes a wheel rotation speed random determination process (S60). Through this process, the mass controller 70 determines the initial rotation speed of the wheel 51 by referring to the wheel rotation speed table of FIG. 17. That is, the mass controller 70 randomly determines the initial

rotation speed, based on the lever speed signal received from the station 10 in which the lever device 40 has been operated. Next, the mass controller 70 executes a resulting symbol random determination process to randomly determine a resulting symbol from the plurality of symbols 21 (S61).

[0117]

Next, the mass controller 70 executes a wheel stop-effect pattern random determination process (S62).

Through this process, the mass controller 70 determines the stop effect of the wheel 51, by referring to the wheel stop-effect pattern table of FIG. 18. That is, the mass controller 70 randomly determines the point position (i.e., stop position) of the pointer 53 in the spot 52 with the resulting symbol, and determines the rotation angle of the wheel 51 based on the pointing position thus determined. Further, at the same time, the mass controller 70 also determines the rotation angles for the pins 54 which contact the pointer 53, before the wheel 51 stops. Then, the mass controller 70 executes a wheel rotation speed curve adjustment process (S63). Through this process, the mass controller 70 controls the motion controller 66, and determines the rotation speed curve of the wheel 51 within a predetermined period, based on the rotation speed data.

[0118]

After that, the mass controller 70 executes a game running process, to rotate and stop the wheel 51 (S64). Then, the mass controller 70 executes a winning determine process based on the resulting symbol (S65), and transmits a result signal including the result information to the station 10 (S66). After that, the mass controller 70 ends the unit game, transmits the unit game end signal to each station 10 (S67), and ends the routine.

[0119]

10 Through the above described operation of the gaming machine 1, the wheel 51 used in the game is automatically rotated or stopped by controlling the mass controller 70. Thus, unlike a simple roulette game, various effects can be provided to the game, and the entertainment  
15 characteristic of the game is improved. The wheel 51 used in the game is also rotatable by having the player operate the lever device 40 provided to the station 10. Since the game can be started by a hand of the player, the player may feel more involved in the game and become more  
20 enthusiastic about the game. Further, since the player of only one station 10 among the plurality of stations 10 is able to operate the lever device 40, the player who can operate the lever device 40 feels he/she is more advantaged than the other players. This makes the  
25 operation of the lever device 40 very attractive to the

players, and as a result, the entertainment characteristic of the game is improved.

[0120]

The embodiment of the present invention, described hereinabove, is solely to serve as an example of the present invention, and is not at all intended to limit the present invention. It is obvious for a person with ordinary skill in the art that the specific structures of the means may be suitably designed and altered as needed. Further, the effects described in the embodiment of the present invention are no more than examples of most preferable effects yielded by the present invention, and the effects of the present invention are not limited to those described in the embodiment of the present invention.

[0121]

For example, in the gaming machine 1 of the present embodiment, the wheel 51 of the roulette device 50 is set upright. The wheel 51 however may be set horizontally, as long as the players playing the game on the plurality of stations 10 are able to see the symbols 21 on the wheel 51.

[0122]

Further, in the gaming machine 1 of the present embodiment, the form of displaying the odds in the odds display area 33 is changed by pressing the payout display changing button 12 provided to the station 10. The



present invention however is not limited to this. For example, the form of displaying the odds may be changed by controlling the operation of the mass controller 70 and the station controller 100. Further, the form of displaying is not limited to the form using "to"; i.e., "2 to 1", "51 to 1". Other forms of displaying are also possible.

[0123]

Further, the detailed description above is mainly focused on characteristics of the present invention to fore the sake of easier understanding. The present invention is not limited to the above embodiments, and is applicable to diversity of other embodiments. Further, the terms and phraseology used in the present specification are adopted solely to provide specific illustration of the present invention, and in no case should the scope of the present invention be limited by such terms and phraseology. Further, it will be obvious for those skilled in the art that the other structures, systems, methods or the like are possible, within the spirit of the present invention described in the present specification. The description of claims therefore shall encompass structures equivalent to the present invention, unless otherwise such structures are regarded as to depart from the spirit and scope of the present invention.

Further, the abstract is provided to allow, through a simple investigation, quick analysis of the technical features and essences of the present invention by an intellectual property office, a general public institution, or one skilled in the art who is not fully familiarized with patent and legal or professional terminology. It is therefore not an intention of the abstract to limit the scope of the present invention which shall be construed on the basis of the description of the claims. To fully understand the object and effects of the present invention, it is strongly encouraged to sufficiently refer to disclosures of documents already made available.

[0124]

The detailed description of the present invention provided hereinabove includes a process executed on a computer. The above descriptions and expressions are provided to allow the one skilled in the art to most efficiently understand the present invention. A process performed in or by respective steps yielding one result or blocks with a predetermined processing function described in the present specification shall be understood as a process with no self-contradiction. Further, the electrical or magnetic signal is transmitted/received and written in the respective steps or blocks. It should be noted that such a signal is expressed in the form of bit,

value, symbol, text, terms, number, or the like solely for the sake of convenience. Although the present specification occasionally personifies the processes carried out in the steps or blocks, these processes are essentially executed by various devices. Further, the other structures necessary for the steps or blocks are obvious from the above descriptions.

[0125]

The present invention is applicable to a gaming machine which awards a payout according to the resulting symbol on a wheel which rotates on the premise of betting a game value from a gaming terminal.

[0126]

Throughout this specification and the claims which follow, unless the context requires otherwise, the word "comprise", and variations such as "comprises" or "comprising", will be understood to imply the inclusion of a stated integer or step or group of integers or steps but not the exclusion of any other integer or step or group of integers or steps.

[0127]

The reference in this specification to any prior publication (or information derived from it), or to any matter which is known, is not, and should not be taken as an acknowledgment or admission or any form of suggestion

that that prior publication (or information derived from it) or known matter forms part of the common general knowledge in the field of endeavour to which this specification relates.

5

THE CLAIMS DEFINING THE INVENTION ARE AS FOLLOWS:

1. A gaming machine, comprising:

a wheel having a plurality of symbol arrangement areas in which a plurality of symbols are arranged on the same plane, respectively, the wheel being capable of rotating in such a manner that the symbols are visible;

a plurality of gaming terminals each having a display for displaying a plurality of bet areas corresponding to the symbols, each gaming terminal structured to receive a bet of a game value on a bet area and to award a payout based on odds set for the bet area; and

a center controller which stores a bet area on which a bet is placed and a game value placed as the bet in each gaming terminal, determines a resulting symbol from the plurality of symbols through the rotation of the wheel, and awards a payout based on the resulting symbol and the odds set for the bet area on which the bet is placed in the gaming terminal,

wherein the center controller adjusts a payout rate by changing the odds set for the bet areas of the gaming terminals.

2. A gaming machine, comprising:

a wheel having a plurality of symbol arrangement areas in which a plurality of symbols are arranged on the

same plane, respectively, the wheel being capable of rotating in such a manner that the symbols are visible;

5 a plurality of gaming terminals each having a display for displaying a plurality of bet areas corresponding to the symbols, each gaming terminal structured to receive a bet of a game value on a bet area and to award a payout based on odds set for the bet area; and

10 a center controller which stores a bet area on which a bet is placed and a game value placed as the bet in each gaming terminal, determines a resulting symbol from the plurality of symbols through the rotation of the wheel, and awards a payout based on the resulting symbol and the odds set for the bet area on which the bet is placed in the gaming terminal,

15 wherein the payout rate may be adjusted by changing the number of symbols arranged in the symbol arrangement areas.

3. The gaming machine according to claim 1, wherein the center controller switches a form of displaying the odds set for the bet areas on the display of the gaming terminal.

4. The gaming machine according to claim 2, wherein the center controller switches a form of displaying the odds

1/22

FIG.1

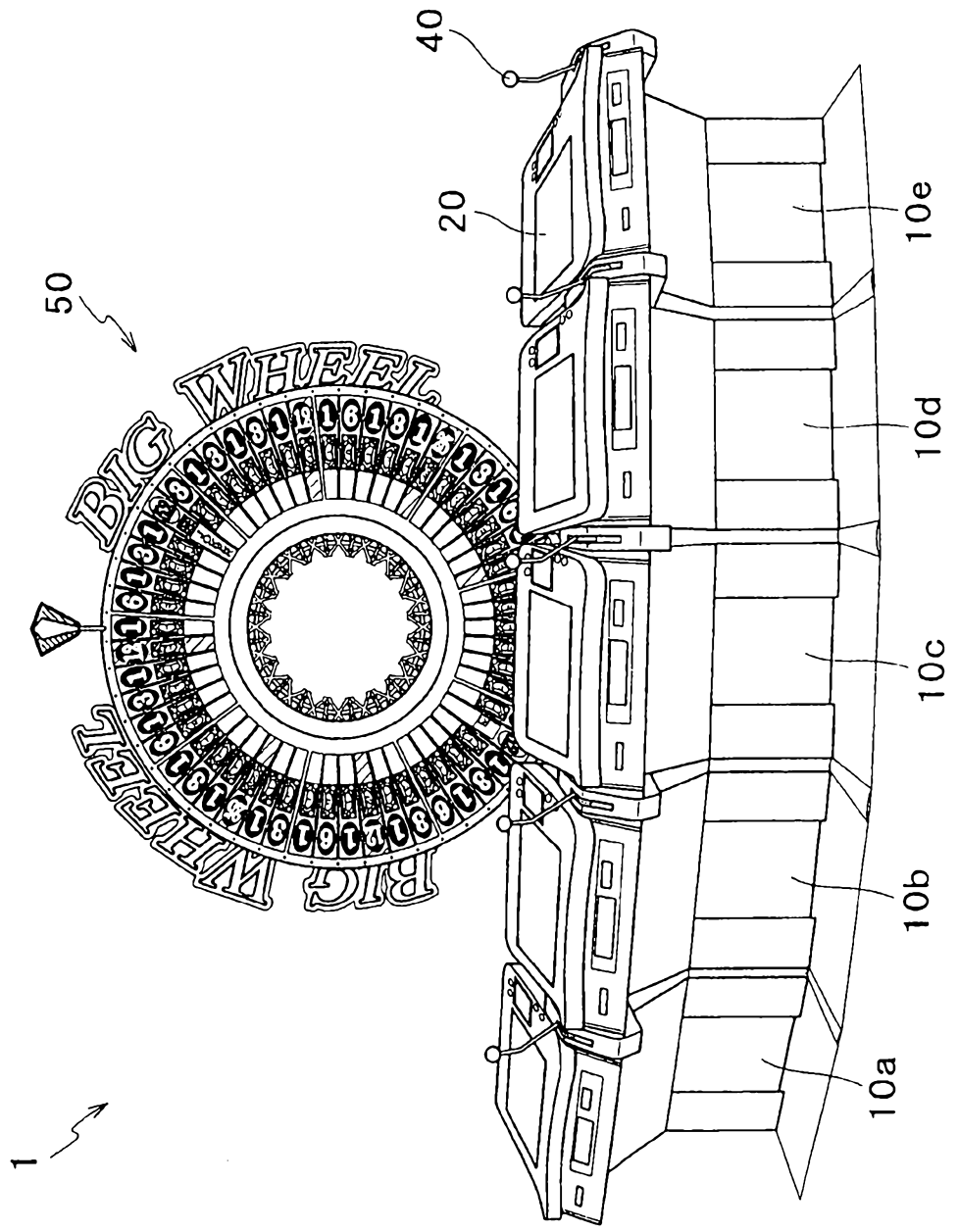

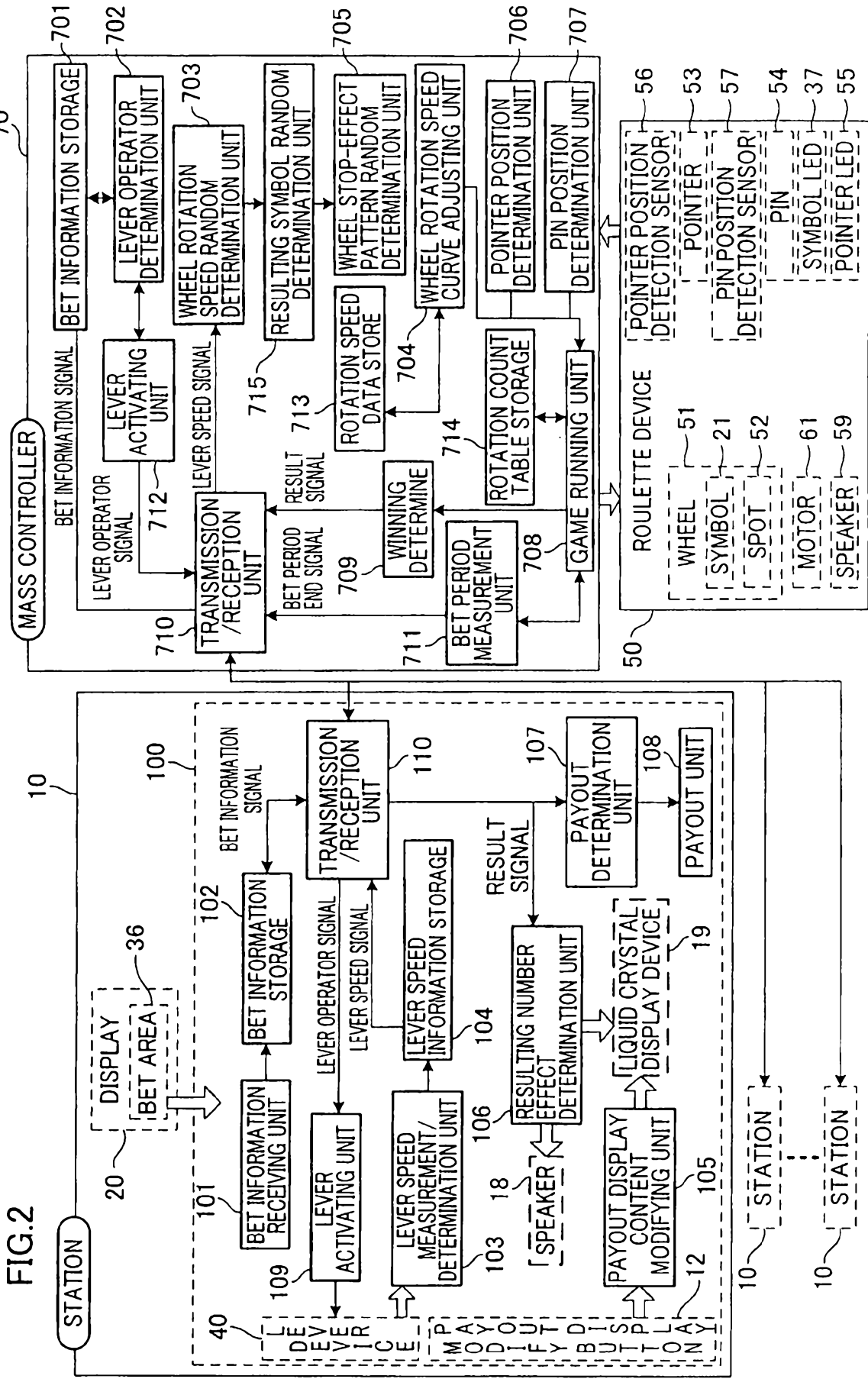



FIG.3

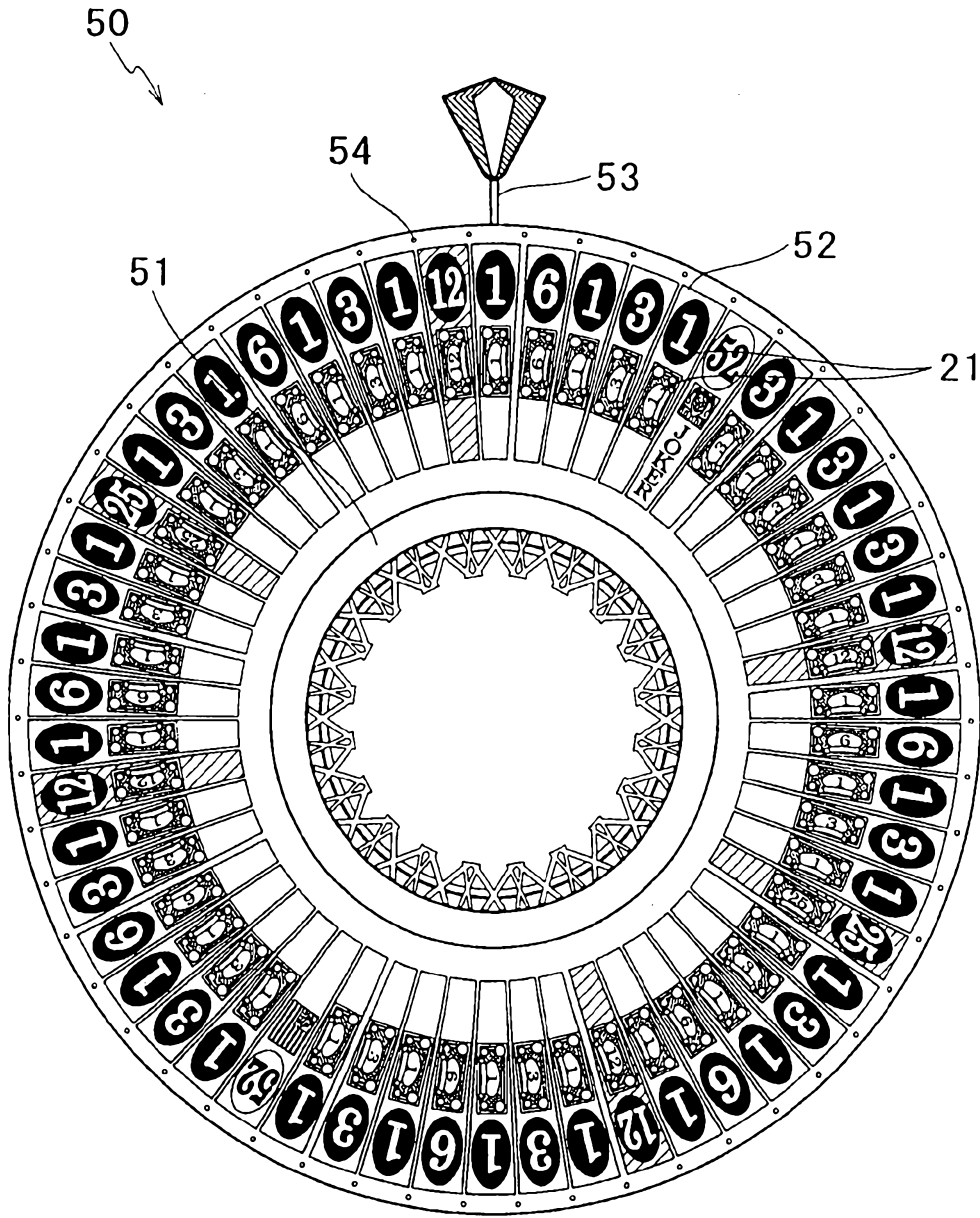

FIG.4

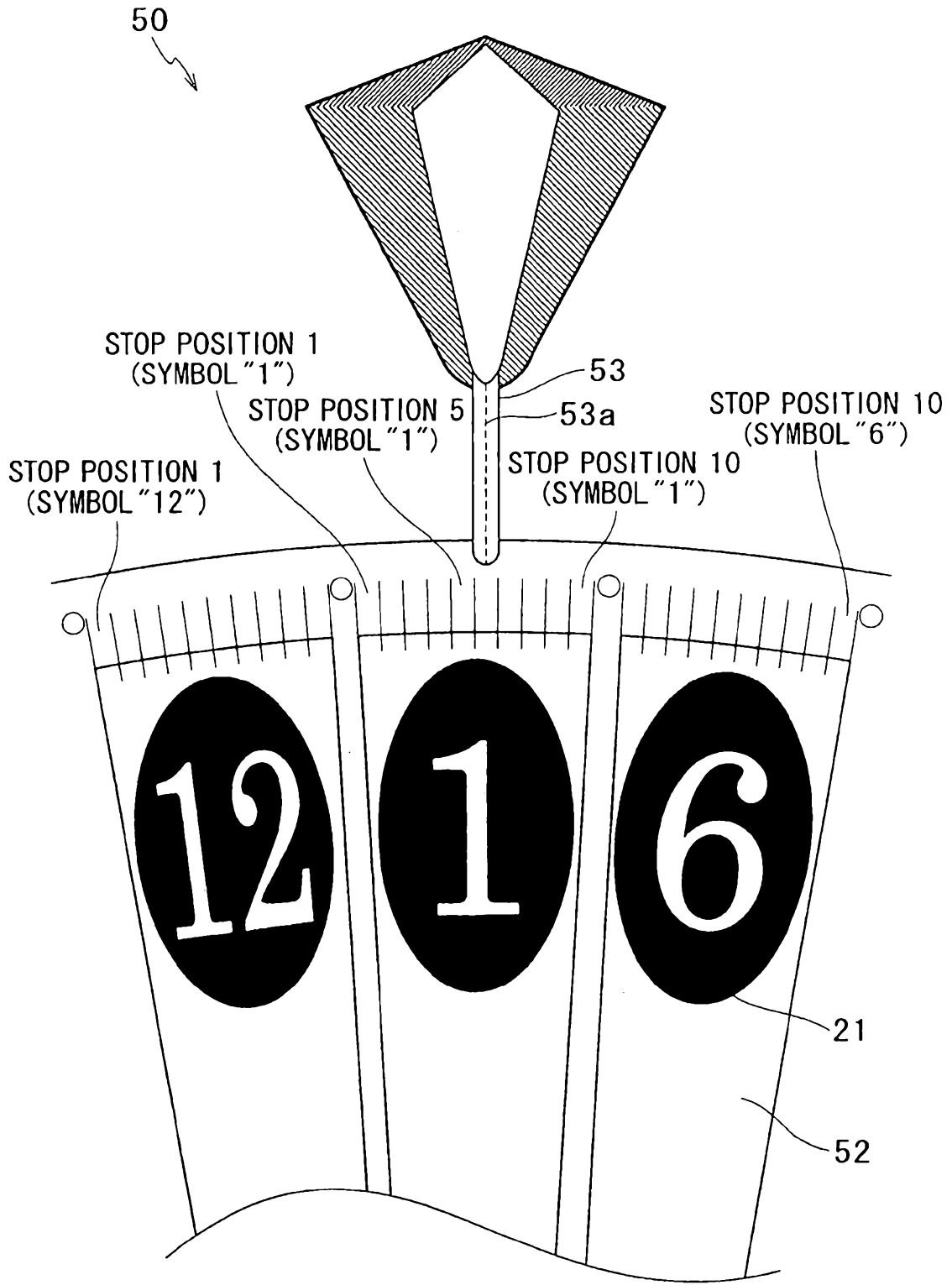

FIG.5A

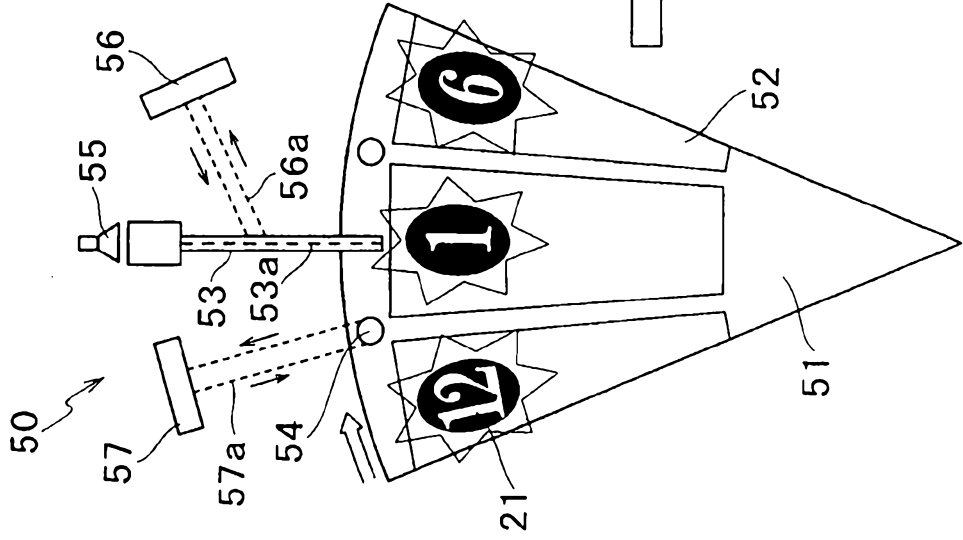

FIG.5B

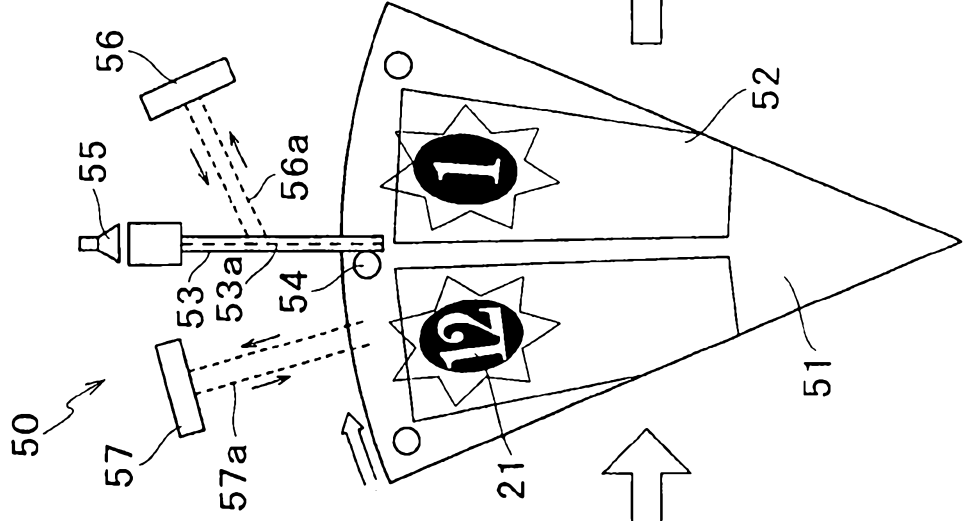

FIG.5C

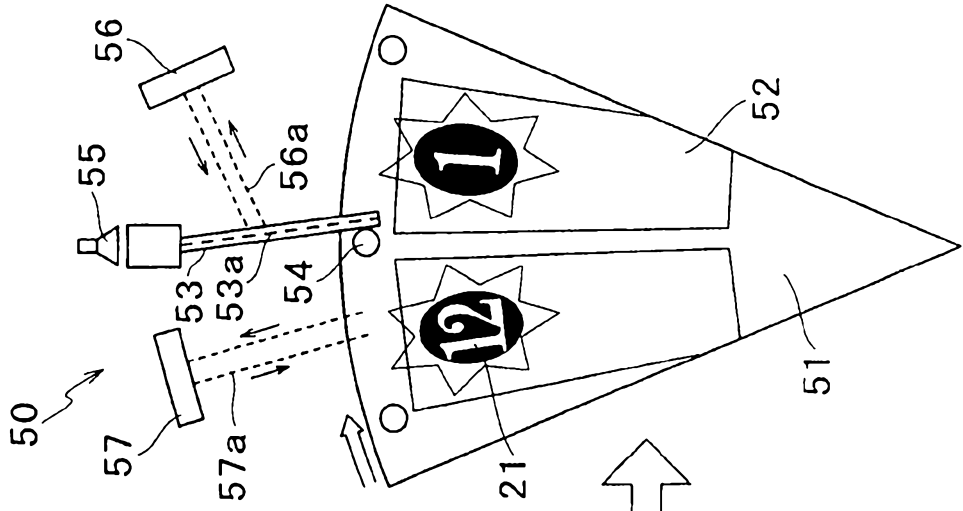

FIG.6D

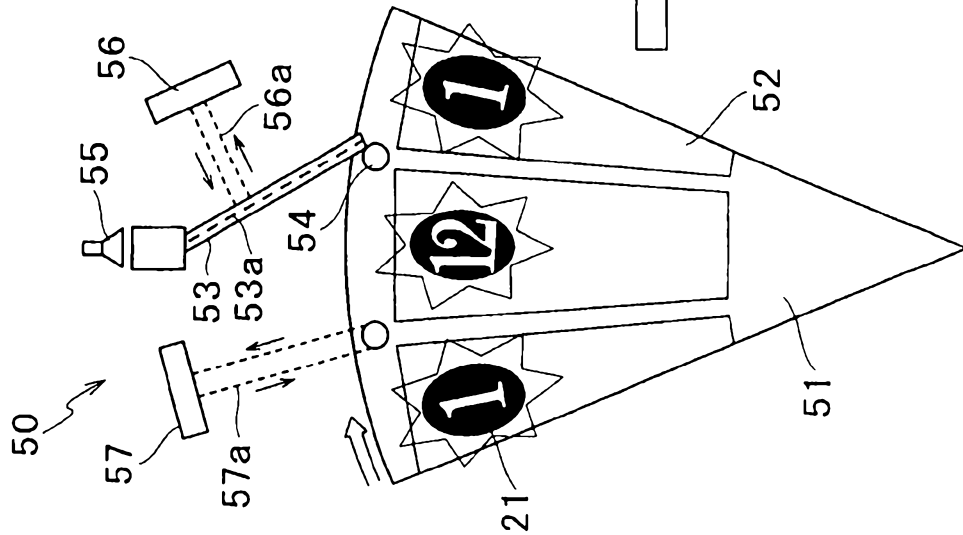

FIG.6E

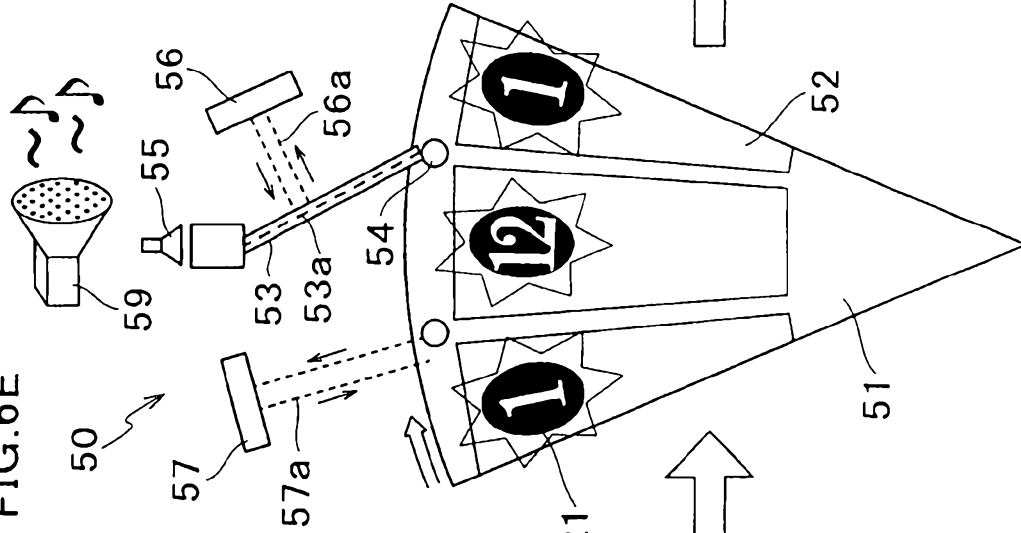

FIG.6F

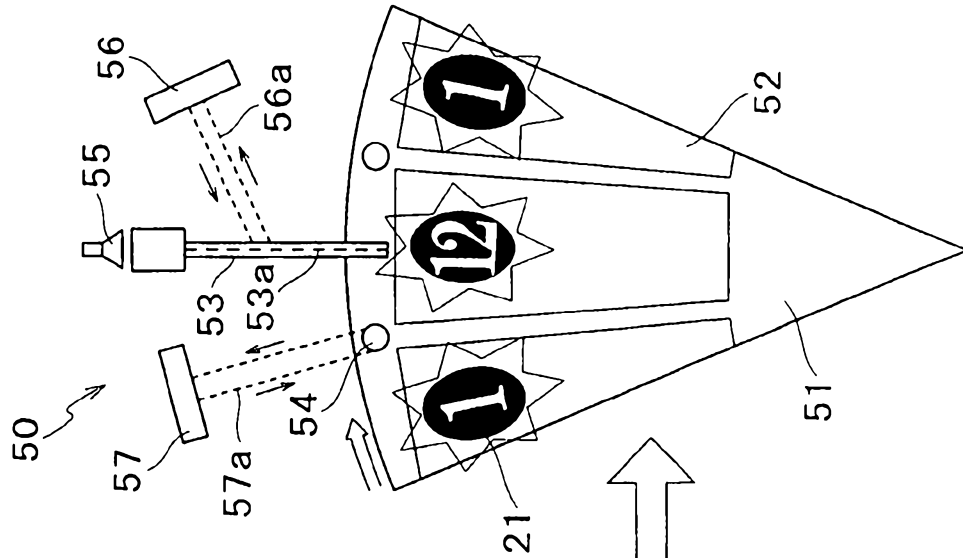

FIG.7A

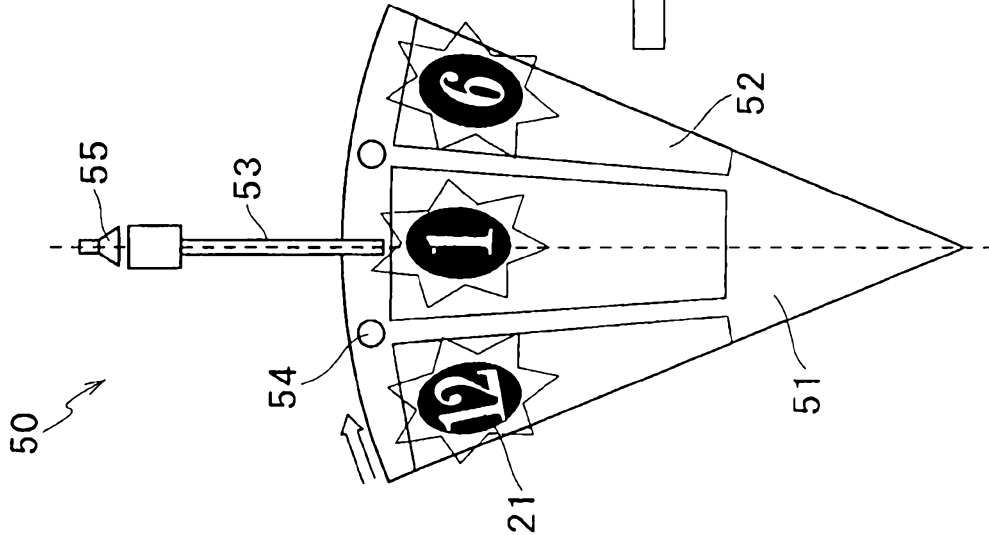

FIG.7B

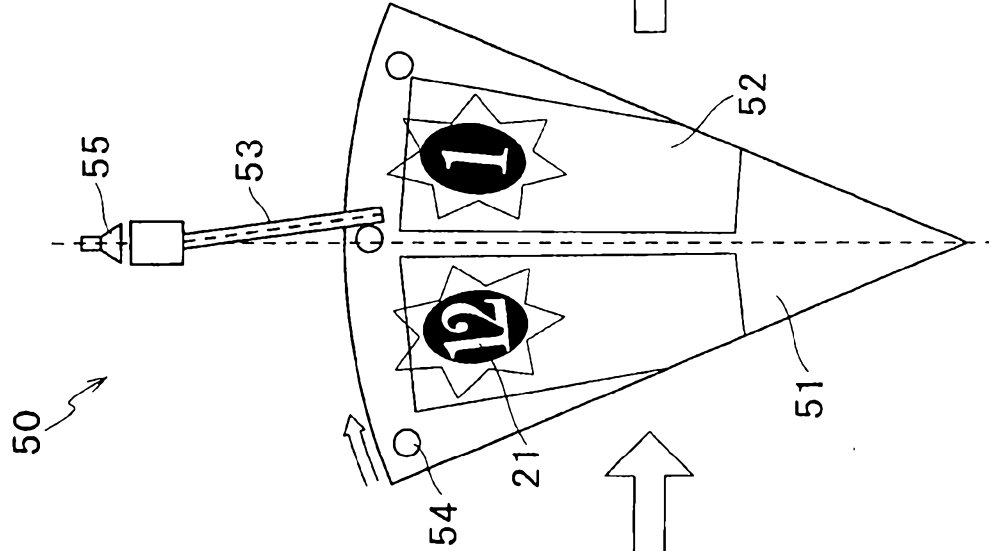

FIG.7C

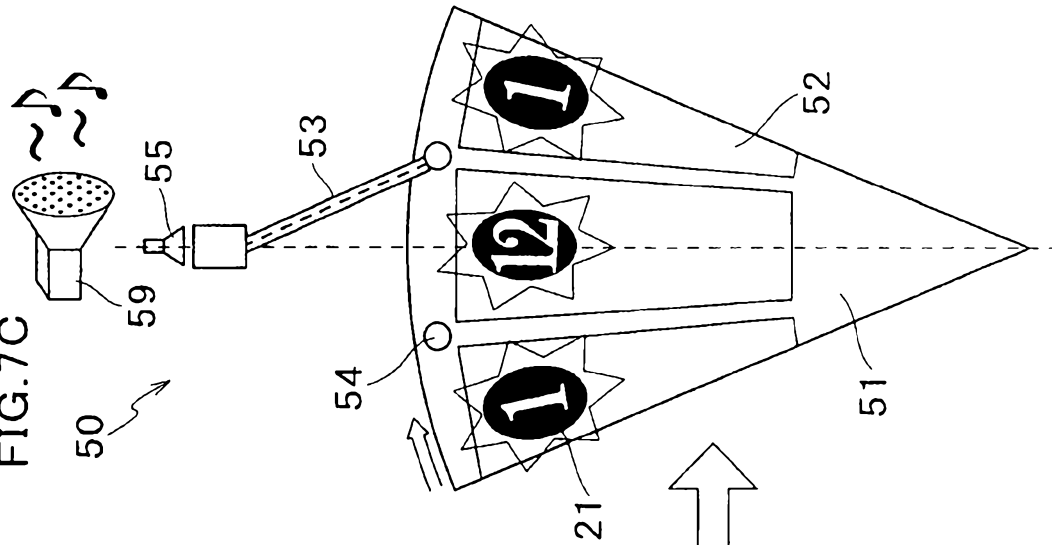
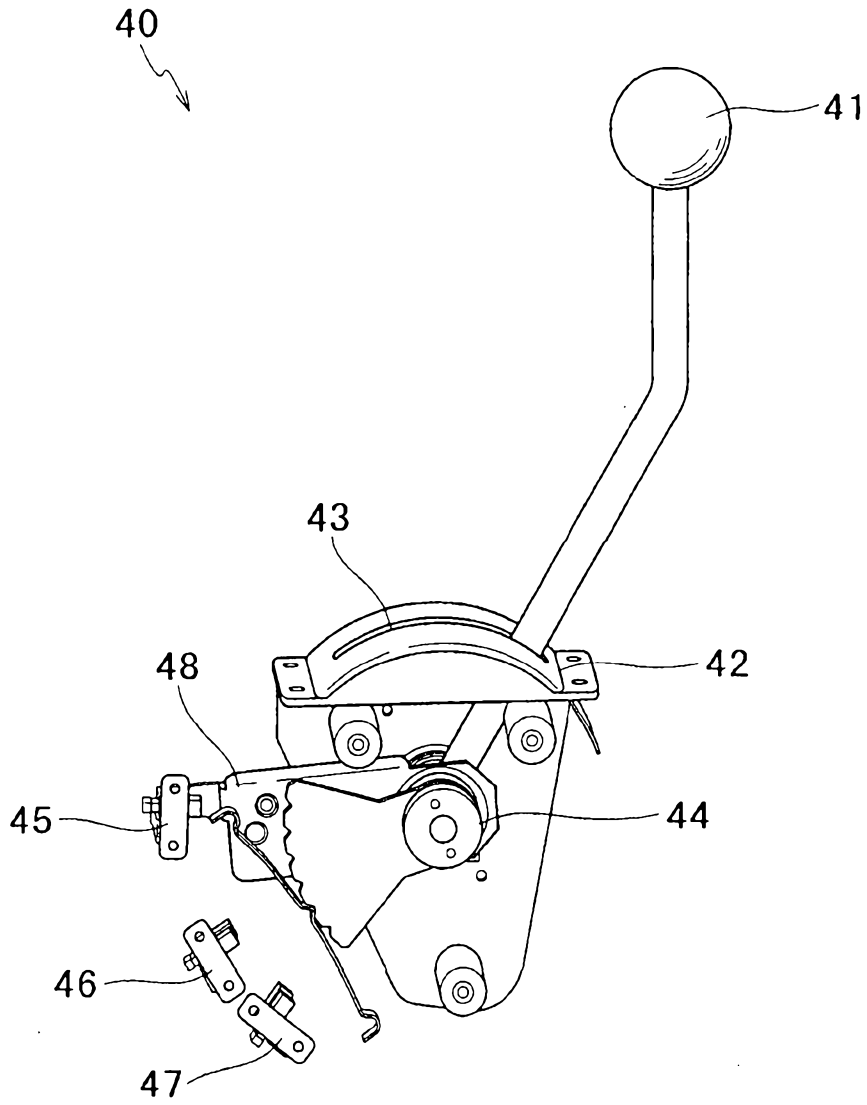

FIG.8



9 / 22

FIG. 9

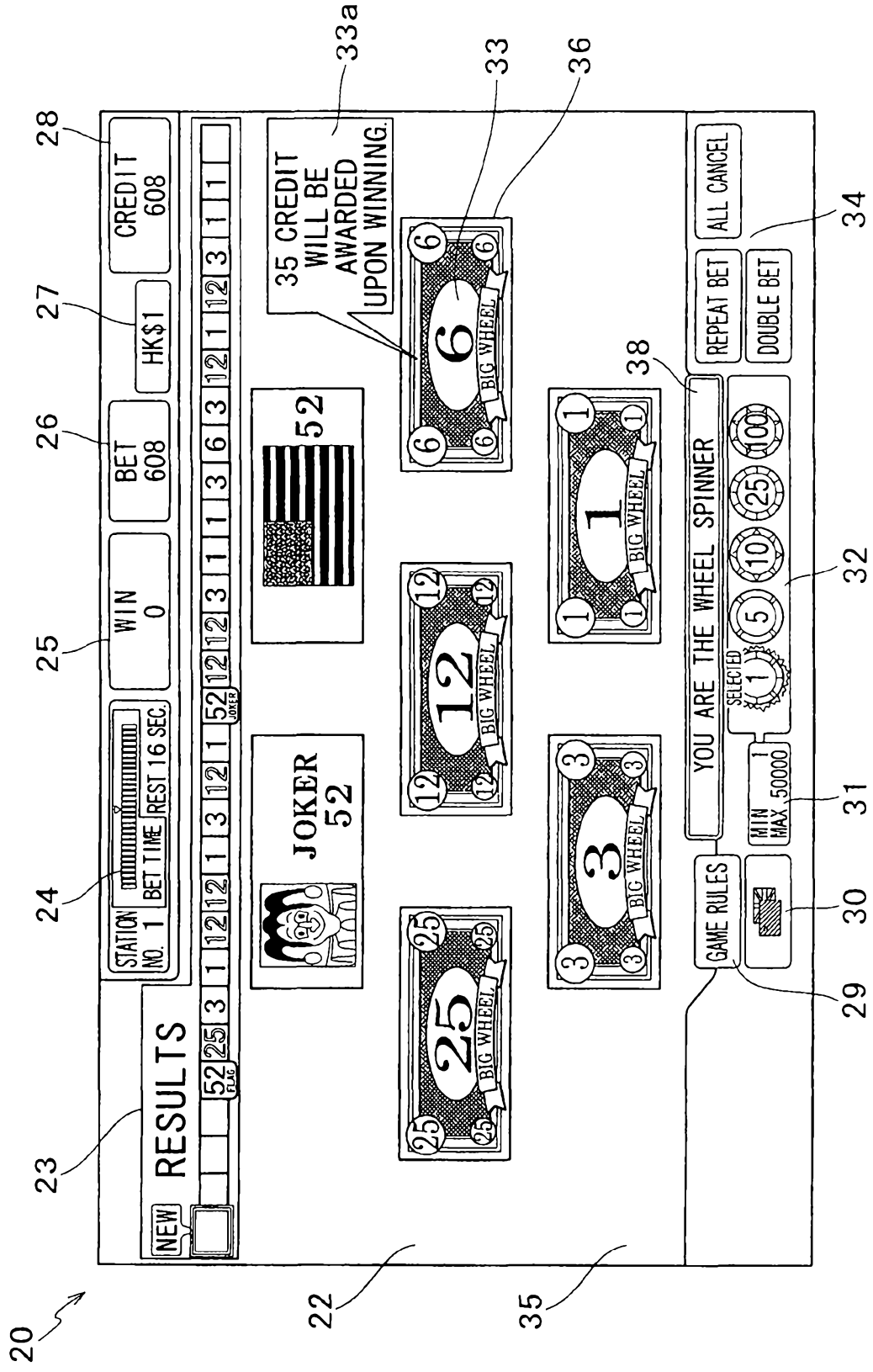
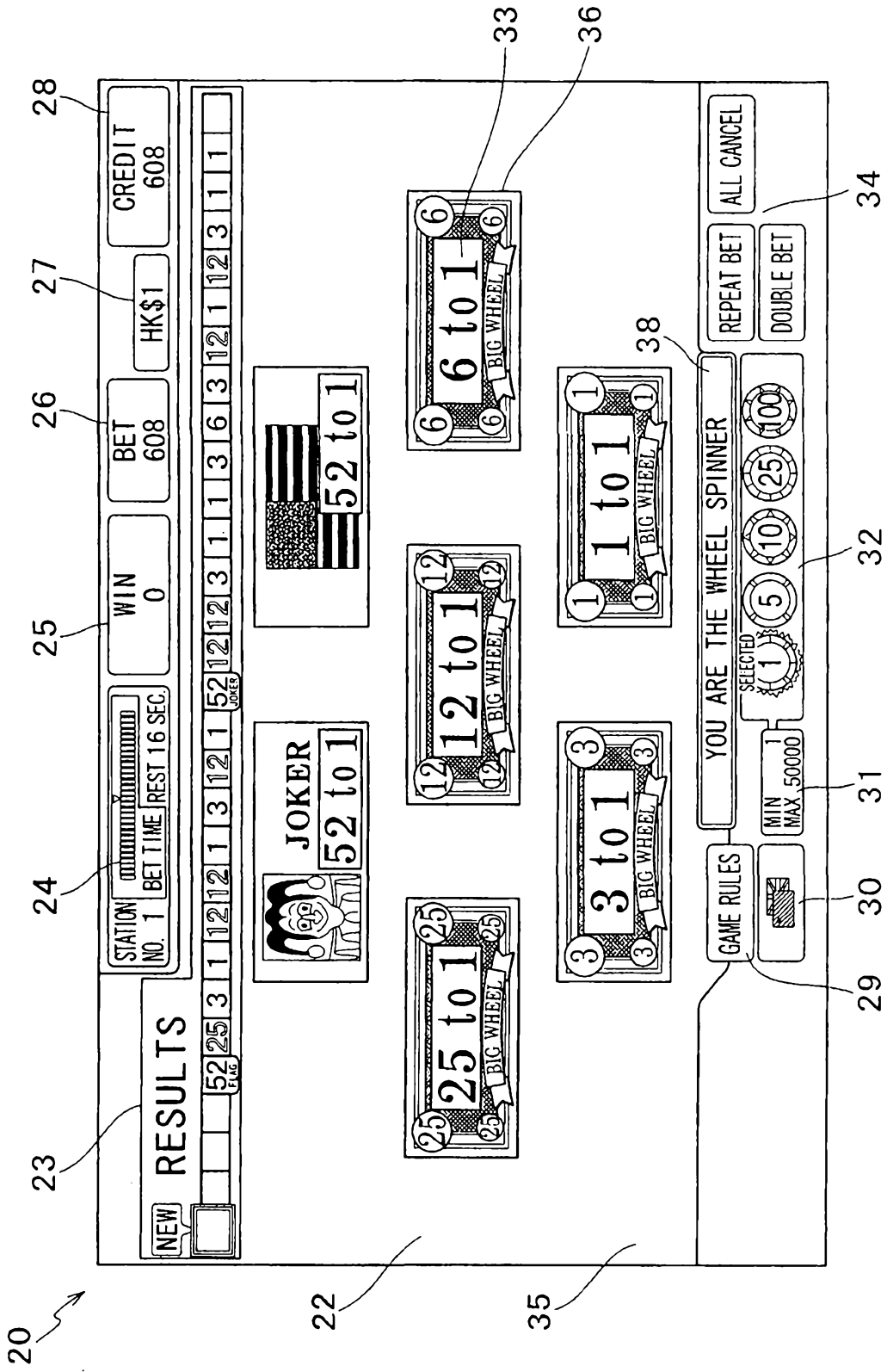

FIG. 10





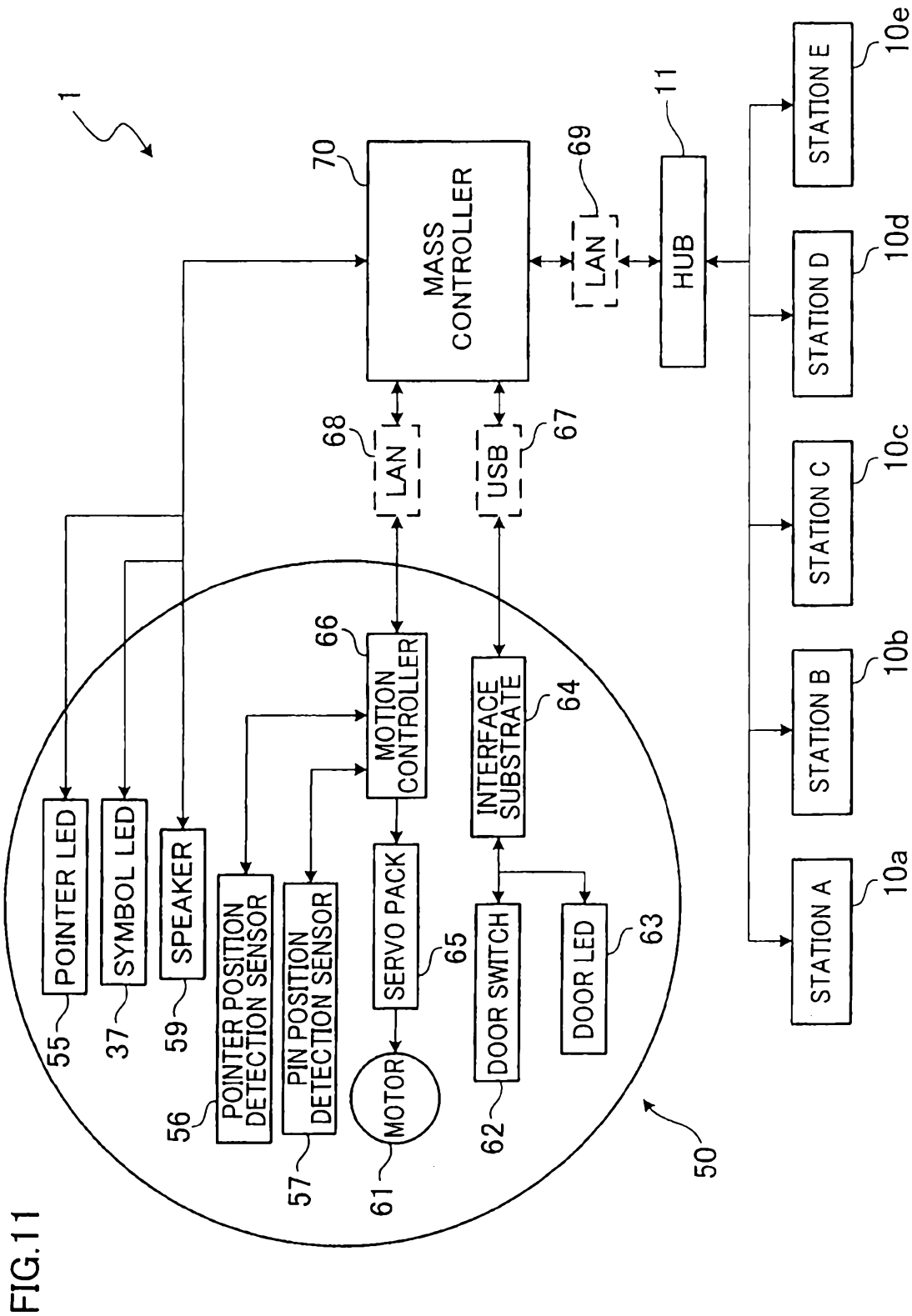

FIG.11

FIG.12

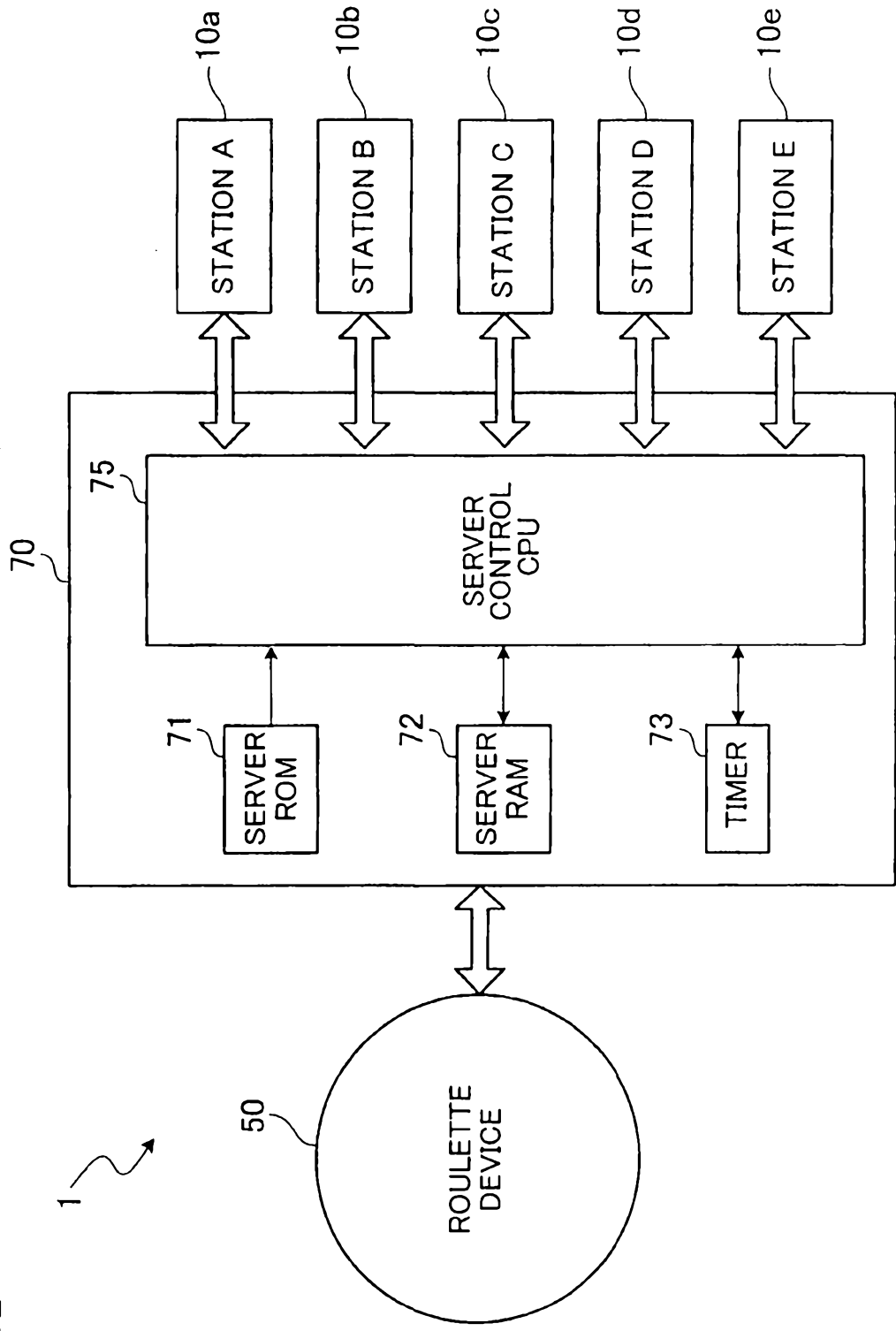

FIG.13

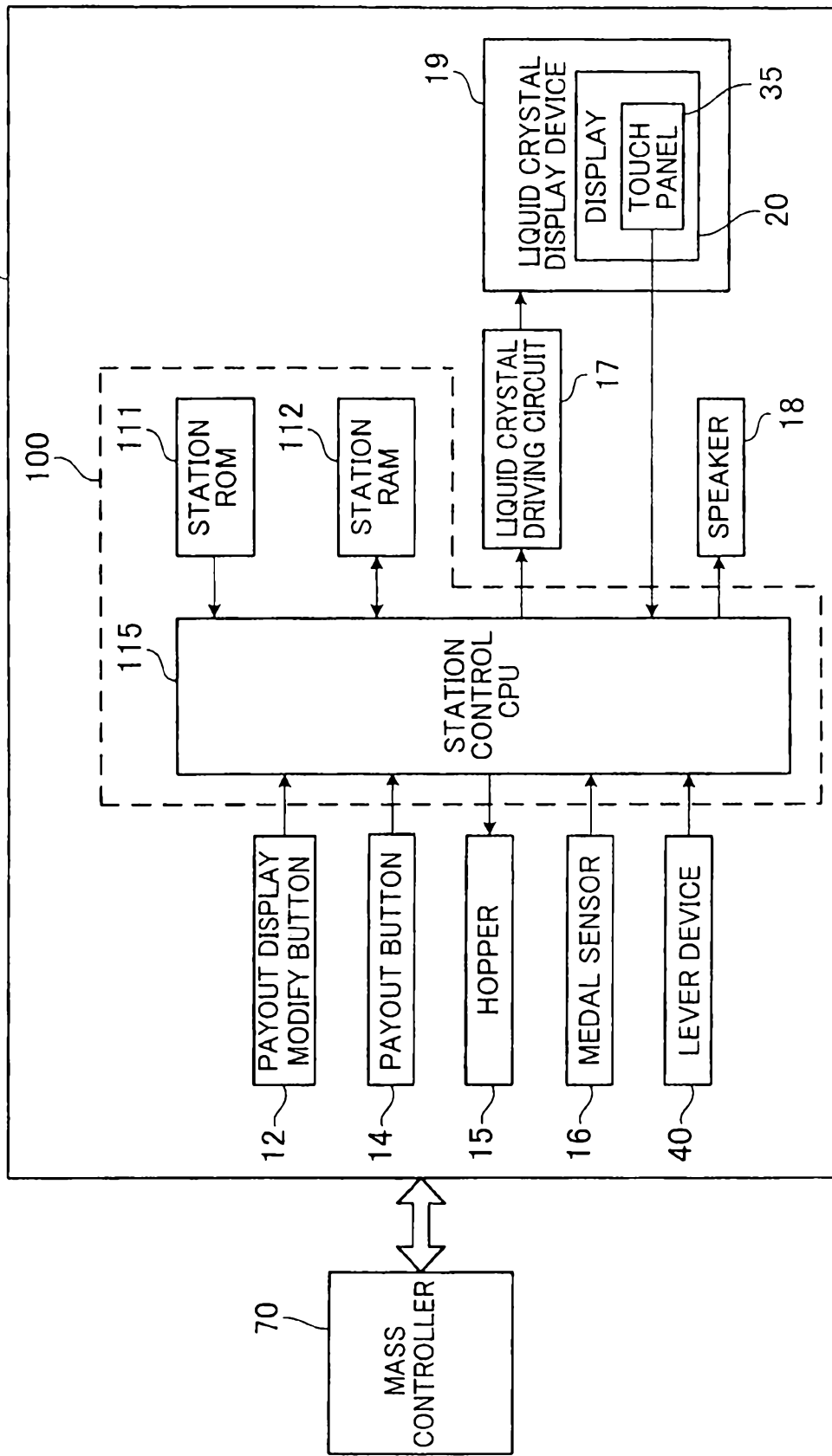

FIG.14

BET INFORMATION MANAGING TABLE

BET TYPE	BET AMOUNT
1	5
3	25
6	0
12	0
25	0
JOKER	10
LOGO	0
TOTAL BET AMOUNT	40

FIG.15

LEVER OPERATION TIME TABLE

LEVER OPERATION PERIOD	SPEED LEVEL
~5msec	Slow
6~9msec	Normal
10msec~	Fast

FIG.16

STATION MANAGING TABLE

STATION	BET TYPE								TOTAL BET AMOUNT	LEVER OPERATOR
	1	3	6	12	25	JOKER	LOGO			
a	5	25	0	0	0	10	0	40	0	
b	10	10	5	0	0	0	0	25	0	
c	0	15	0	25	10	0	5	55	1	
d	0	40	0	0	0	0	0	40	0	
e	30	0	0	0	0	5	10	45	0	

FIG.17

WHEEL ROTATION SPEED TABLE

SPEED LEVEL	INITIAL ROTATION SPEED
Slow	8rpm
	9rpm
Normal	10rpm
	11rpm
Fast	12rpm
	13rpm

FIG.18

WHEEL STOP-EFFECT PATTERN TABLE

STOP POSITION	WHEEL STOP DETERMINATION
1	0
2	0
3	0
4	0
5	0
6	0
7	0
8	0
9	0
10	1



FIG.19A PAYOUT PATTERN TABLE  
TYPE A

SYMBOL	THE NUMBER OF SPOTS	PROBABILITY	ODDS		PAYOUT RATE
1	26	0.48148	2	1:1	96.296%
3	13	0.24074	4	3:1	96.296%
6	7	0.12963	7	6:1	90.741%
12	4	0.07407	13	12:1	96.296%
25	2	0.03704	26	25:1	96.296%
JOKER	1	0.01852	53	52:1	98.148%
LOGO	1	0.01852	53	52:1	98.148%
TOTAL PAYOUT RATE					96.032%

FIG.19B

TYPE B

SYMBOL	THE NUMBER OF SPOTS	PROBABILITY	ODDS		PAYOUT RATE
1	26	0.48148	2	1:1	96.296%
3	13	0.24074	4	3:1	96.296%
6	7	0.12963	7	6:1	90.741%
12	4	0.07407	13	12:1	96.296%
25	2	0.03704	26	25:1	96.296%
JOKER	1	0.01852	52	51:1	96.296%
LOGO	1	0.01852	52	51:1	96.296%
TOTAL PAYOUT RATE					95.503%

FIG.19C

TYPE C

SYMBOL	THE NUMBER OF SPOTS	PROBABILITY	ODDS		PAYOUT RATE
1	26	0.48148	2	1:1	96.296%
3	13	0.24074	4	3:1	96.296%
6	7	0.12963	7	6:1	90.741%
12	4	0.07407	13	12:1	96.296%
25	2	0.03704	26	25:1	96.296%
JOKER	1	0.01852	51	50:1	94.444%
LOGO	1	0.01852	51	50:1	94.444%
TOTAL PAYOUT RATE					94.974%

FIG.20

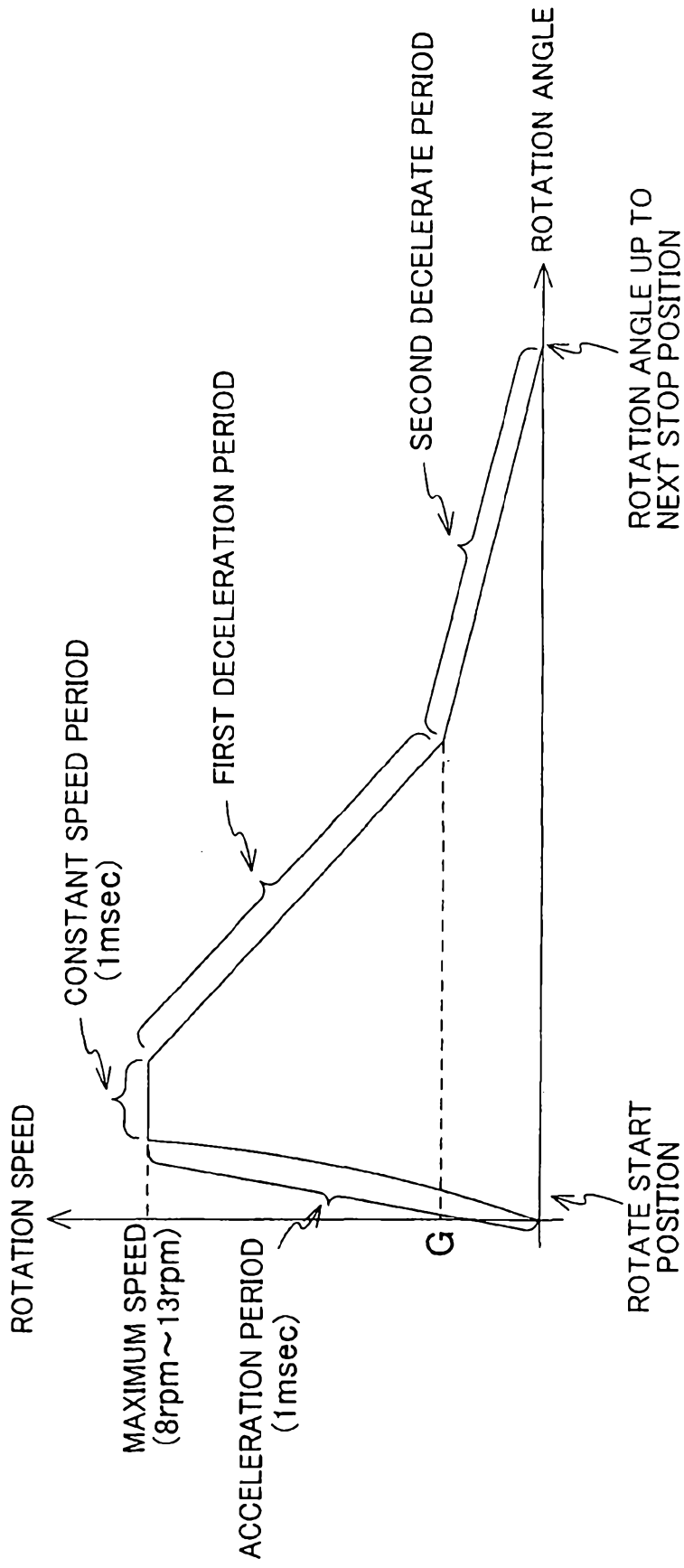

FIG.21

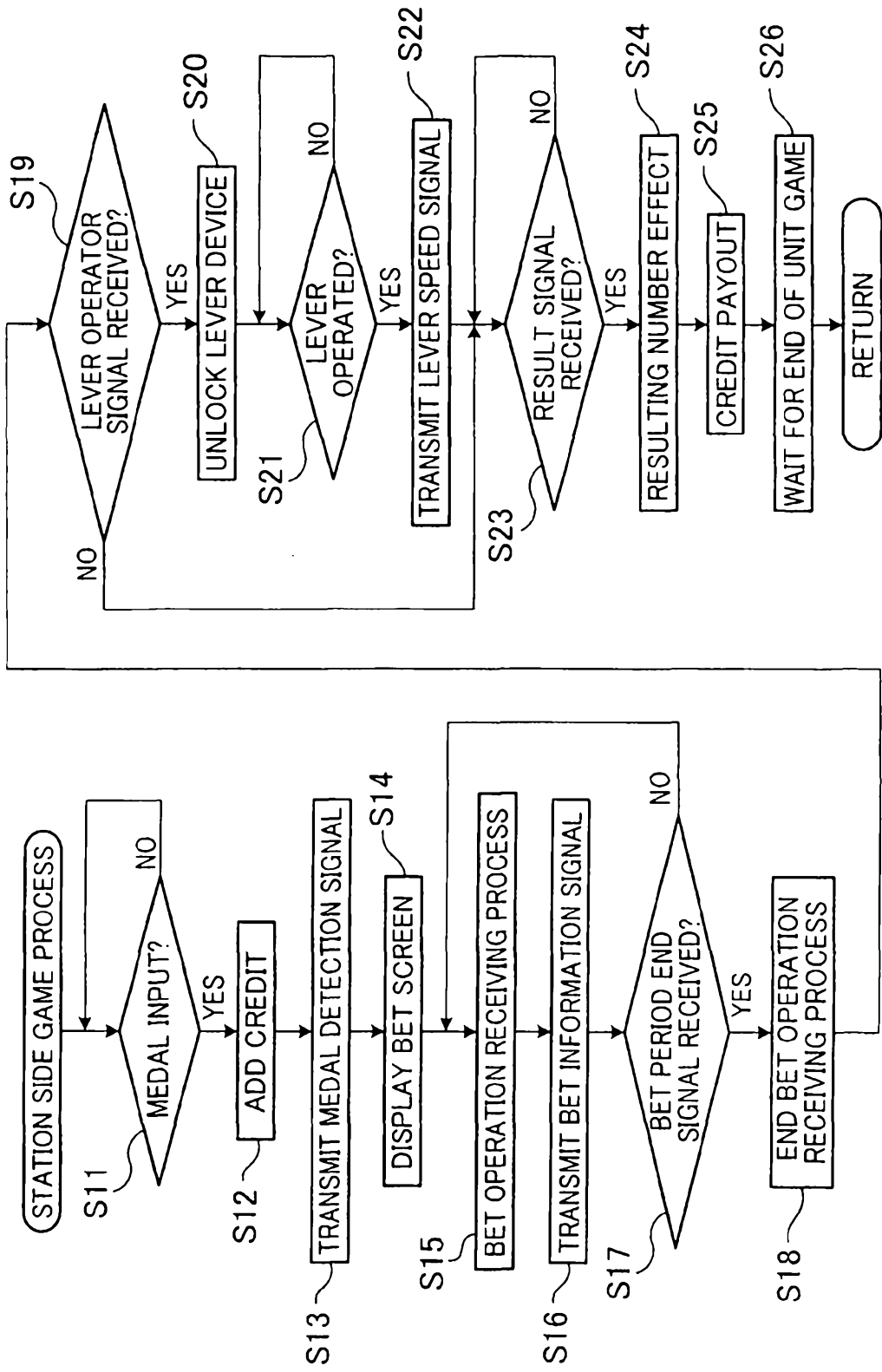

FIG.22

