

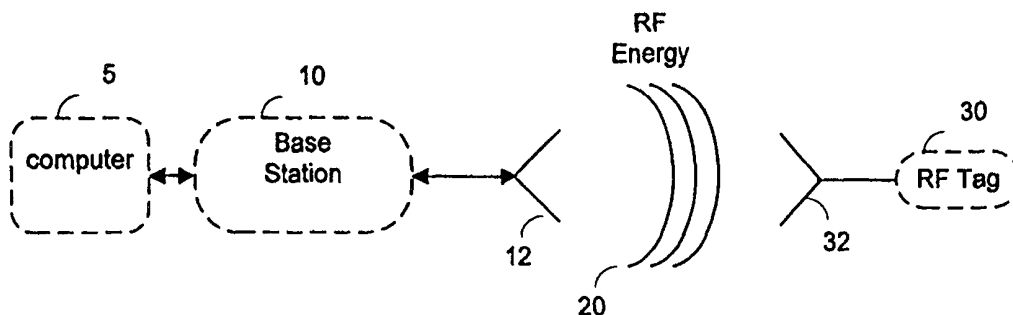

INTERNATIONAL APPLICATION PUBLISHED UNDER THE PATENT COOPERATION TREATY (PCT)

<p>(51) International Patent Classification ⁷ : G06K 19/07</p>	<p>A1</p>	<p>(11) International Publication Number: WO 00/03352 (43) International Publication Date: 20 January 2000 (20.01.00)</p>
<p>(21) International Application Number: PCT/US99/15456 (22) International Filing Date: 9 July 1999 (09.07.99) (30) Priority Data: 09/114,037 10 July 1998 (10.07.98) US (71) Applicant: INTERMEC IP CORP. [US/US]; 21900 Burbank Boulevard, Woodland Hills, CA 91367-7418 (US). (72) Inventor: FRIEDMAN, Daniel, J.; 83 Main Street #D-6, Tarrytown, NY 10591 (US). (74) Agent: SHERMAN, John, H.; Intermec Technologies Corporation, Legal Dept., 550 2nd Street S.E., Cedar Rapids, IA 52401-2023 (US).</p>		<p>(81) Designated States: CA, JP, European patent (AT, BE, CH, CY, DE, DK, ES, FI, FR, GB, GR, IE, IT, LU, MC, NL, PT, SE). Published <i>With international search report.</i></p>

(54) Title: APPARATUS AND METHOD FOR RECOVERING DATA SIGNALS SENT TO RF TAGS



(57) Abstract

A method is presented, where data is recovered from a data signal sent by a base station to a radio frequency (RF) transponder (tag), where the data signal is sampled at a plurality of times (t_n) after a corresponding plurality of transitions (T_n) in the data signal.

FOR THE PURPOSES OF INFORMATION ONLY

Codes used to identify States party to the PCT on the front pages of pamphlets publishing international applications under the PCT.

AL	Albania	ES	Spain	LS	Lesotho	SI	Slovenia
AM	Armenia	FI	Finland	LT	Lithuania	SK	Slovakia
AT	Austria	FR	France	LU	Luxembourg	SN	Senegal
AU	Australia	GA	Gabon	LV	Latvia	SZ	Swaziland
AZ	Azerbaijan	GB	United Kingdom	MC	Monaco	TD	Chad
BA	Bosnia and Herzegovina	GE	Georgia	MD	Republic of Moldova	TG	Togo
BB	Barbados	GH	Ghana	MG	Madagascar	TJ	Tajikistan
BE	Belgium	GN	Guinea	MK	The former Yugoslav Republic of Macedonia	TM	Turkmenistan
BF	Burkina Faso	GR	Greece			TR	Turkey
BG	Bulgaria	HU	Hungary	ML	Mali	TT	Trinidad and Tobago
BJ	Benin	IE	Ireland	MN	Mongolia	UA	Ukraine
BR	Brazil	IL	Israel	MR	Mauritania	UG	Uganda
BY	Belarus	IS	Iceland	MW	Malawi	US	United States of America
CA	Canada	IT	Italy	MX	Mexico	UZ	Uzbekistan
CF	Central African Republic	JP	Japan	NE	Niger	VN	Viet Nam
CG	Congo	KE	Kenya	NL	Netherlands	YU	Yugoslavia
CH	Switzerland	KG	Kyrgyzstan	NO	Norway	ZW	Zimbabwe
CI	Côte d'Ivoire	KP	Democratic People's Republic of Korea	NZ	New Zealand		
CM	Cameroon			PL	Poland		
CN	China	KR	Republic of Korea	PT	Portugal		
CU	Cuba	KZ	Kazakstan	RO	Romania		
CZ	Czech Republic	LC	Saint Lucia	RU	Russian Federation		
DE	Germany	LI	Liechtenstein	SD	Sudan		
DK	Denmark	LK	Sri Lanka	SE	Sweden		
EE	Estonia	LR	Liberia	SG	Singapore		

APPARATUS AND METHOD FOR RECOVERING DATA SIGNALS SENT TO RF TAGS

FIELD OF THE INVENTION.

The field of the invention is the field of Radio Frequency (RF) Transponders (RF Tags), wherein a Base Station sends power and information to one or more RF Tags which contain logic and memory circuits for storing information about objects, people, items, or animals associated with the RF Tags. The RF Tags can be used for identification and location (RFID Tags) of objects and to send information to the base station by modulating the load on an RF Tag antenna.

BACKGROUND OF THE INVENTION

RF Tags can be used in a multiplicity of ways for locating and identifying accompanying objects, items, animals, and people, whether these objects, items, animals, and people are stationary or mobile, and transmitting information about the state of the of the objects, items, animals, and people. It has been known since the early 60's in US Patent 3,098,971 by R.M. Richardson, that electronic components on a transponder could be powered by radio frequency (RF) power sent by a "base station" at a carrier frequency and received by an antenna on the tag. The signal picked up by the tag antenna induces an alternating current in the antenna which can be rectified by an RF diode and the rectified current can be used for a power supply for the electronic components. The tag antenna loading is changed by something that was to be measured, for example a microphone resistance in the cited patent. The oscillating current induced in the tag antenna from the incoming RF energy would thus be changed, and the change in the oscillating current led to a change in the RF power radiated from the tag antenna. This change in the radiated power from the tag antenna can be picked up by the base station antenna and thus the microphone would in effect broadcast power without itself having a self contained power supply. In the cited patent, the antenna current also oscillates at a harmonic of the carrier frequency because the diode current contains a doubled frequency component, and this frequency can be picked up and sorted out from the carrier frequency much more easily than if it were merely reflected. Since this type of tag carries no power

supply of its own, it is called a “passive” tag to distinguish it from an active tag containing a battery. The battery supplies energy to run the active tag electronics, but not to broadcast the information from the tag antenna. An active tag may also change the loading on the tag antenna for the purpose of transmitting information to the base station.

The “rebroadcast” of the incoming RF energy at the carrier frequency is conventionally called “back scattering”, even though the tag broadcasts the energy in a pattern determined solely by the tag antenna and most of the energy may not be directed “back” to the transmitting antenna.

In the 70's, suggestions to use tags with logic and read/write memories were made. In this way, the tag could not only be used to measure some characteristic, for example the temperature of an animal in US patent 4,075,632 to Baldwin et. al., but could also identify the animal. The antenna load was changed by use of a transistor.

Prior art tags have used electronic logic and memory circuits and receiver circuits and modulator circuits for receiving information from the base station and for sending information from the tag to the base station.

US Patent No 5,214,410, hereby incorporated by reference, teaches a method for a base station to communicate with a plurality of Tags .

Prior art tags typically use a number of discrete components connected together with an antenna. However, to substantially reduce the cost of the tags, a single chip connected to an antenna must be used. In order to increase the range of passive tags, and to conserve battery life of active tags, the minimum current necessary for the tag functions must be used.

Prior art tags use receivers with automatic gain control to boost received signal or limit received signal when the tags are far from or near to the base station. The automatic gain control mechanisms take up a lot of space on the chip, and use too much current.

RELATED PATENTS AND APPLICATIONS

Related U.S. patents assigned to the assignee of the present invention include: 5,521,601; 5,528,222; 5,538,803; 5,550,547; 5,552,778; 5,554,974; 5,563,583; 5,565,847; 5,606,323; 5,635,693; 5,673,037; 5,680,106; 5,682,143; 5,729,201; 5,729,697; 5,736,929; 5,739,754; 5,786,626; 5,821,859; 5,831,532; 5,850,181; 5,874,902; and 5,912,632. Patent applications assigned to the assignee of the present invention include: U.S. Application No. 08/694,606 filed 9 August 1996 entitled RFID System with Broadcast Capability by

Cesar et al. ; PCT International application published as Publication Number WO96/13793 published 9 May 1996; and PCT International Application No. PCT/US98/23121 filed 30 October 1998 (Docket No. DN38386 PCT). The above identified patents and patent applications are hereby incorporated by reference.

SUMMARY OF THE INVENTION

The digital signals received by the tag with no automatic gain control are sampled at different points in the signal waveform depending on the prior history of the signal. In this way, automatic gain control is not needed to provide a series of pulses which have "perfect" shape and duration. In particular, for a signal with a plurality of types of transitions T_n , the data are sampled at different times t_n after each type of transition. In the particular case of Manchester encoding, the data are sampled at a first time after a midbit rise in the signal, and at a second time after a midbit fall in signal. The transitions at the bit boundaries are ignored.

BRIEF DESCRIPTION OF THE DRAWINGS

- Fig. 1 shows a system of a base station sending RF energy to an RF tag
- Fig. 2 shows a block diagram of the tag antenna and part of the RF tag.
- Fig. 3 is a block diagram of the tag clock section.
- Fig. 4 shows the RF power for a steadily modulated signal sent from the base station with the rise and fall times of the signal exaggerated.
- Fig. 5 shows the digital data output to the tag data recovery signal from this signal if the tag is far from the base station.
- Fig. 6 shows the digital data output to the tag data recovery signal from this signal if the tag is near to the base station.
- Fig. 7a shows a square wave data signal sent out from a base station to a tag.
- Fig. 7b shows the signal produced from the digital output of the tag receiver when the tag is close to the base station.
- Fig. 7c shows the clock signal output of the tag oscillator.
- Fig. 8 is a flow chart of a method of the invention.

DETAILED DESCRIPTION OF THE INVENTION

Fig. 1 shows a system of a base station 10 having an associated computer 5 sending RF energy 20 from base station antenna 12 to a tag antenna 32 associated with an RF tag 30. The RF frequency f_0 is preferably above 100 MHz, more preferably above 900 MHz, and most preferably above 2,300 MHz. The RF signal is preferably amplitude modulated at a frequency f_1 greater than 1 KHz, more preferably between 5 and 150 KHz, and most preferably between 20 and 60 KHz. However, the RF signal may also be modulated by frequency modulation or by phase modulation methods, as is well known in the art of RF signal propagation. The RF tag 30 may be a passive tag which receives all the energy needed to carry out the tag functions from the RF field broadcast by the base station, or it may be an active tag which carries a battery to store the required energy. Both types of tags can change the loading on the tag antenna 32 to change the antenna reflectivity and thus communicate with the base station 10. Active tags may also generate and transmit RF signals back to the base station.

Fig. 2 shows a block diagram of the tag antenna 32 and part of the RF tag 30. (Neither a possible RF tag transmitter section nor other sections such as measurement sections nor alarm section nor enable/disable sections are shown.) The RF antenna 32 feeds RF power to the tag rectification power supply 34. A battery tag would replace block 34 with a battery (not shown) In the preferred embodiment shown in Fig. 2, a tag rectification signal receiving section 36 comprising an RF diode, a signal capacitor, and a signal capacitor current drain is separate from the tag rectification power supply, but the oscillator section of the invention is also contemplated in the case that section 36 is part of the tag rectification power supply 34. The tag power supply 34 supplies current at voltages VDD, and optionally voltages VPMR, and

VNMR on lines 52, 54, and 56 respectively. These lines are used to power and control the various devices on the tag. The RF antenna 32 has two connections to the tag 30, denoted here by lines 50 and 58. Line 58 is the conventional ground.

The tag rectification signal receiving section 36 receives an RF signal, which is preferably amplitude modulated at a frequency f_1 , from the antenna 32 over line 50, and rectifies and demodulates the RF signal and delivers a digital signal to the rest of the tag electronics over line 62. If the RF is modulated with a steady modulation frequency f_1 , the output of the signal receiving section 36 is preferably a series of square pulses of unit voltage at a frequency f_1 . However, any pattern or subpattern in the signal sent out from the base station could be used to generate an output of the signal receiving section 36 in order to adjust the frequency and optionally the phase of the tag oscillator.

The tag clock section 40 receives the digital demodulated digital signal from line 62 and sets the tag oscillator frequency using the modulation frequency f_1 of the modulated RF signal.

The tag clock section 40 delivers a clock signal on line 102 to the tag logic section 42, to the tag memory section 44, and to other tag electronic sections as needed. The tag logic section 42 communicates with the tag memory section 44 over communication channel 64.

Fig. 3 is a block diagram of the tag clock section 40. The tag oscillator 100 frequency is set by the voltages supplied by a connection denoted 302 from a calibrate module 300. The clock ticks are passed from the oscillator 100 over line 306 and 308. A local clock counter 200 counts the clock ticks since the clock counter has been reset and passes the count to the calibrate module 300 via a connection 304. The calibrate module 300 resets the local clock counter 200 via the connection 304, (and optionally resets the phase of the oscillator 100 over connection 116,) on a rising edge of the digital input signal on line 62, and sets the voltages controlling the frequency of oscillator 100 to give a set number of counts between two rising edges of the digital input signal 62 when the base station 10 is sending a steadily modulated RF signal. The oscillator 100 frequency is thus determined by the modulation frequency of the RF energy 20 transmitted by the base station 10. While the calibrate module may carry out its functions using a rising edge of the digital input signal, it is clear to one skilled in the art that the falling edge of the digital signal, or indeed any characteristic of the signal on line 62, may serve as well. The calibrate module 300 supplies a local clock signal to the tag electronics over line 102.

Digital signals passed from the tag analog receiving section 36 to the tag data recovery system can have different widths (if no automatic gain control circuit is used) depending on the range of the tag to the base station and the relative orientation of the tag antenna and the base station antenna.

Fig. 4 shows the RF power for a steadily amplitude modulated signal sent from the base station with the rise and fall times of the signal exaggerated. This signal is clipped by the tag to give a "unit" voltage if the signal is above a threshold voltage, and a zero voltage if the signal is below the threshold voltage. The threshold may be high up the shoulder of the pulse if the tag is a long way from the base station, or if the tag antenna is not correctly oriented, so that the signal received by the tag is weak. The threshold may be very near the baseline if the tag is close to the base station, and a lot of power is received at the tag.

Fig. 5 shows the digital data output to the tag data recovery section from the signal in fig. 4 if the tag is far from the base station. This signal is somewhat exaggerated in that it shows a threshold very near the maximum of the analog signal, which in practice would not be used because of fluctuations in the data signal.

Fig. 6 shows the digital data output to the tag data recovery section from this signal if the tag is near to the base station. The broadened pulses and distorted pulses are particularly injurious to the data recovery process when the tag is close to the base station and the tag electronics clips the signals very close to the baseline.

Signals sent to the tag comprise a series of bits. In one such encoding system, Manchester encoded signal bits are sent as a pair of one "on" period of the RF field and an equally long "off" period. In the middle of each bit sent, the RF power changes from "off" to "on" or vice versa. There must always be a change in the middle of a bit (midbit transition). There could be, or could not be a transition between two bits. There should be no more than one transition between midbit transitions. (An error signal is optionally generated when there is more than one such transition detected by the tag.)

The method of the invention is a method of sampling the signal data at different points in the signal depending on the prior history of the signal. In particular, the signal data is sampled at a plurality of times t_n after a plurality of transitions T_n in the signal data, where n is an integer. In Manchester encoded signals, there are rising and falling midbit transitions in the data signal and rising and falling bit boundary transitions in the data signal. The data are sampled at two different times after a midbit transition,

depending on whether the midbit transition is a rising or falling transition. The bit boundary transitions are ignored.

The apparatus for carrying out the method of the invention is the apparatus of an RF tag carrying an oscillator 100 with a frequency set by the modulation frequency of the base station carrier frequency, as detailed in application number 08/780,765, but the invention would also work in a prior art tag having an oscillator with fixed frequency on the tag. For the following discussion, the tag oscillator is set so that the tag oscillator has an oscillation frequency between 8 and 9 times the modulation frequency of the base station.

The tag local clock counter 200 starts counting the pulses from the tag oscillator at a midbit transition. The tag counter must be within a certain range for a transition to be counted as the next midbit transition. If the count is greater than a certain number, a tag counter reset circuit is enabled. Then, the next transition is counted as the midbit transition.

The tag counter is reset when a midbit transition is detected. The phase of the tag oscillator is also optionally reset on the midbit transitions. The bit boundary transitions are ignored.

An error signal is optionally generated if there are too many counts of the tag counter between midbit transitions. (Long Pulse Error). Long pulses are optionally sent out on purpose by the base station in a first step in the protocol so that the tag can check that the communication protocol is proceeding correctly.

For Manchester encoded signals, the method of the invention samples the signal at count 7 after a midbit rise in signal, and samples after a count of 5 after a midbit fall in signal. The tag oscillator frequency is set at a time when the base station is sending out a steadily modulated carrier frequency, and in general, there will be between 8 and 9 counts of the tag counter between midbit transitions. It is clear to one skilled in the art that the particular counts used may be changed for different systems. For example, the tag oscillator would be more accurately set with respect to the base station modulation frequency if the number of counts between midbit transitions were an integer much greater than 8. However, the circuitry for setting the number higher requires more area on the chip and is thus more costly.

A typical Manchester encoded digital data signal which might be used in a communication system is shown in fig. 7a. The signal is shown as a perfect square wave

with no rise time or fall time. A 0 bit is given by the field off, then on. A 1 bit has the field on, then off. The bits are denoted by the horizontal arrows and are 0 0 0 1 1 0 0. This series of bits is chosen as an example to show that the RF power may be on for the full length of a bit, and off for the full length of a bit. The average duty cycle is always .5 for Manchester encoding if the pulses are not distorted. A typical data recovery system would sample this signal at a fixed time after the midbit transitions and would return data signals as denoted by the up arrows (for ones) and down arrows (for zeros) of fig. 7a.

Fig. 7b shows the signal that might be produced from the digital output of the tag receiver when the tag is close to the base station and when the base station is not sending out a perfect square wave. Note that the duty cycle is much greater than .5, and the "gaps" in the data signal are very much narrower than the gaps of fig. 7a. The midbit transitions are noted, where T_1 denotes a rising midbit transition and T_2 denotes a falling midbit transition. The clock counter is reset and the oscillator phase is reset at the midbit transitions.

Fig. 7c shows the clock signal output of the tag oscillator. The tag oscillator frequency has been set in a prior step so that there are more than 8 and fewer than 9 pulses in one bit time. At every midbit transition, the phase of the tag oscillator and the clock counter are reset. The method of the invention is that the data signal of fig. 7b is sampled on the seventh count or a time t_1 after a midbit rise in the signal, and on the fifth count or a time t_2 after a midbit fall. The up and down arrows in fig. 7c denote that the sampling would return the same pattern of up and down arrows shown in fig. 7a.

Note that always sampling at a clock count of 7 would return the wrong value at point A in fig. 7c, and that always sampling at a clock count of 5 counts would return the wrong value at the points denoted B. If a clock count of 6 were chosen as the sample point, the samples taken at that count next to the points denoted A or B would be taken very close to the edge of the pulse and the results would be unreliable. This method can also be used to compensate for any data-dependent variation in the tag oscillator speed, which is likely to occur for a low power tag oscillator when the incoming power varies.

Fig. 8 shows a flow chart of the method of the invention 500. The tag resets the tag counter and the tag oscillator phase on a midbit transition of the Manchester encoded signal in step 505. The tag also records whether or not the midbit transition was a signal rise. In step 515, the tag counter counts the pulses of the tag oscillator and in decision step 510 the tag decides the next step on the basis of whether the last midbit transition was a

rise in the data signal or a fall in the data signal. In the case of a data rise, the tag checks the tag counter and the decision step 520 decides on a tag counter pulse of 7 to sample the data signal in step 540. The tag passes the sampled data (a zero or a one) to the tag data processing section in step 550. In the case of a data fall, the tag checks the tag counter and the decision step 530 decides on a tag counter pulse of 5 to sample the data signal in step 540. Meanwhile, the tag midbit transition detector is enabled in step 535 as soon as the data has been sampled (either on the count of 5 or 7 depending on whether the previous midbit transition fell or rose). At the next data transition, the tag regards the data transition as a midbit transition and the system returns to step 505. There may or may not be a data transition prior to the data sample being taken, but the tag ignores the transition, if one is present, and relies on the midbit transition history to decide where to sample the data. In this way, the data is sampled at a point well clear of any possible transition.

The method of this invention could be used as well with other well known encoding systems, particularly other biphase encoding techniques such as FM0. Such encoding systems are described in detail in "Digital Communications Fundamentals and Applications", by Bernard Sklar, Prentice Hall, NJ (1988). The above identified publications, books and patents are hereby included by reference. This invention increases the range over which the RF tags may be used.

We claim:

1. A method of recovering data from a data signal sent by a base station to a radio frequency (RF) transponder (tag), comprising;
sampling the data signal at a plurality of times t_n after a plurality of transitions T_n in the data signal, the transitions T_n comprising at least two types of transitions, where t_n is determined by the type of transition T_n .
2. A method of recovering data from a data signal sent by a base station to a radio frequency (RF) transponder (tag), comprising;
detecting selected transitions in the data signal, the transitions being either rising transitions or falling transitions;
measuring the time t starting at each of the selected transitions; and
sampling the data signal at a first time $t = t_1$ if the transition is a rising transition and at a second time $t = t_2$ if the transition is a falling transition.
3. The method of recovering data of claim 2, wherein the step of detecting selected transitions in the data signal is the step of detecting midbit transitions in a Manchester encoded signal.
4. The method of recovering data of claim 2, wherein the step of measuring the time t is the step of counting pulses of a tag oscillator with a tag local clock counter circuit.
5. The method of recovering data of claim 4, wherein the step of sampling the data signal is carried out at a first count of the tag local clock counter circuit if the transition is a rising transition, and is carried out at a second count of the tag local clock counter circuit if the transition is a falling transition.

6. A method of recovering data from a Manchester encoded data signal sent by a base station to a radio frequency (RF) transponder (tag), comprising;
- a) resetting a tag local clock counter on a midbit transition of the signal;
 - b) recording whether the midbit transition was a signal rise or a signal fall;
 - c) counting the pulses of a tag oscillator with the local clock counter, and
 - i) if the midbit transition was a signal rise, sampling the data at a first count of the local tag counter; and
 - ii) if the midbit transition was a signal fall, sampling the data at a second count of the local tag counter.
7. The method of recovering data of claim 6, wherein the step a) of resetting the tag local clock counter also includes resetting the tag oscillator phase.

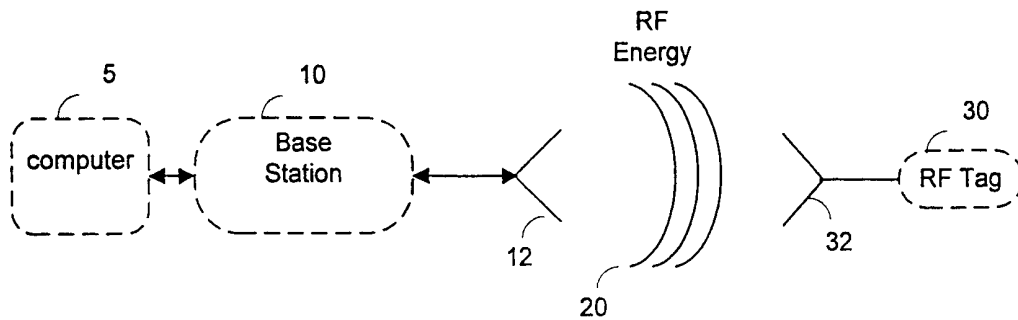

Fig. 1

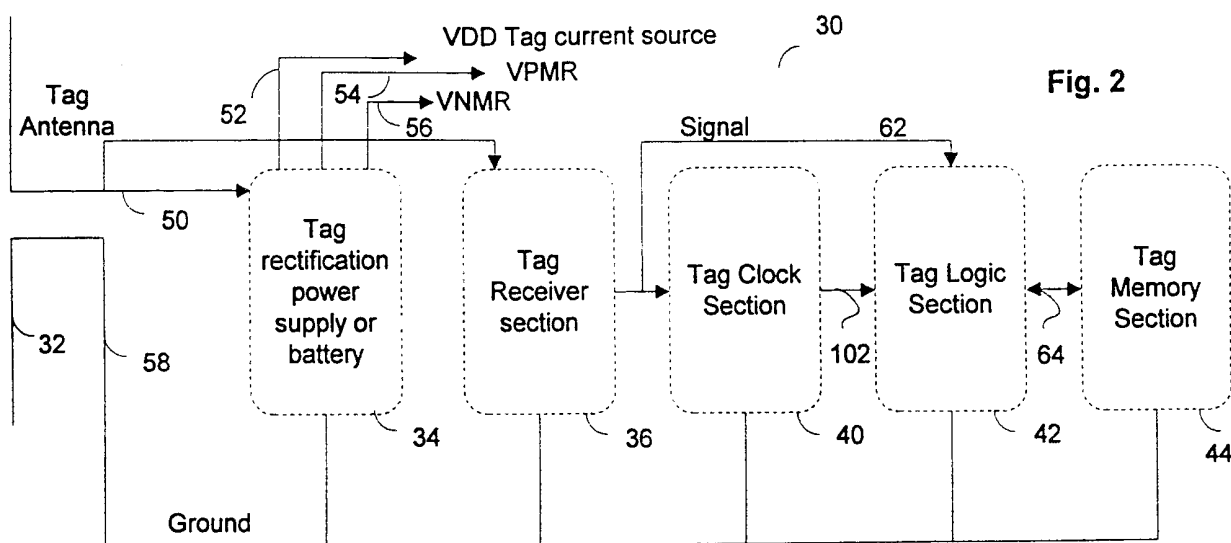

Fig. 2

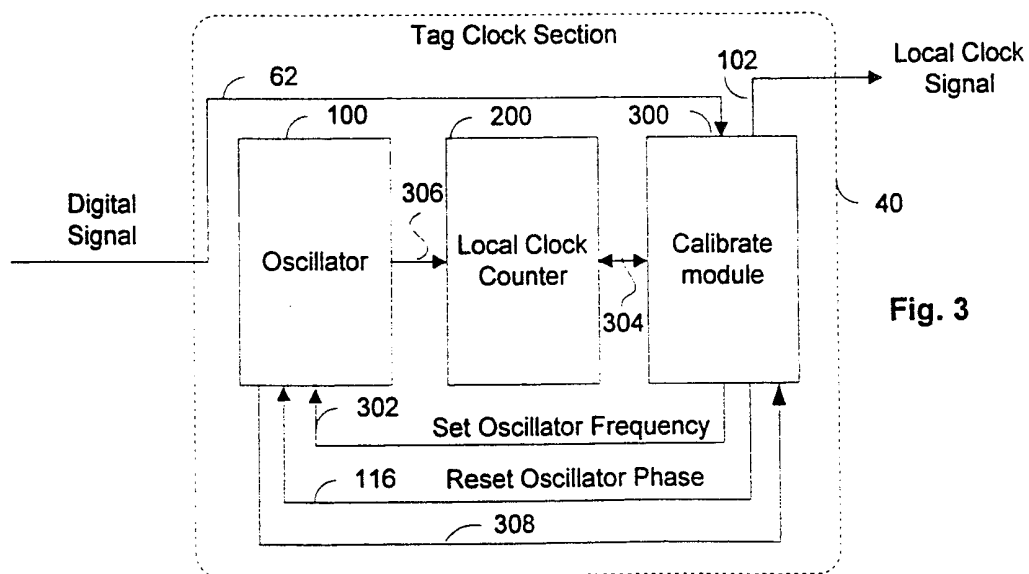
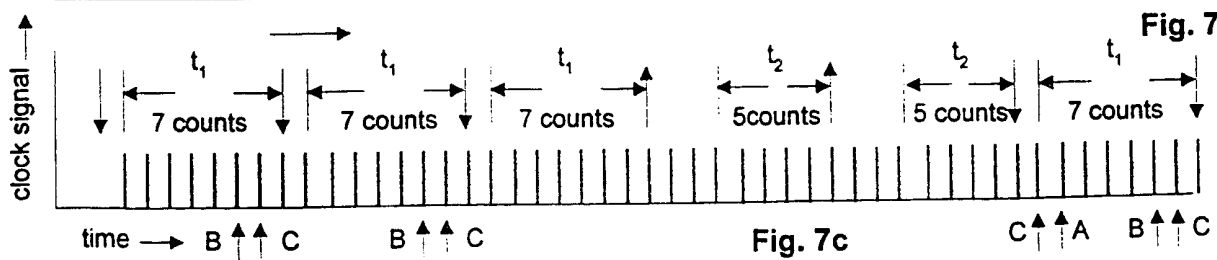
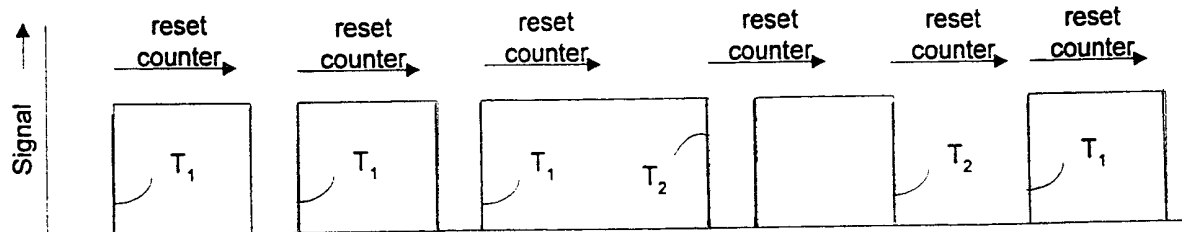
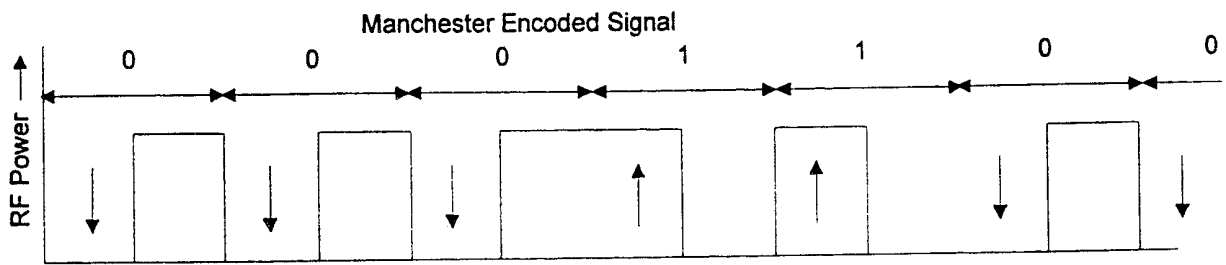
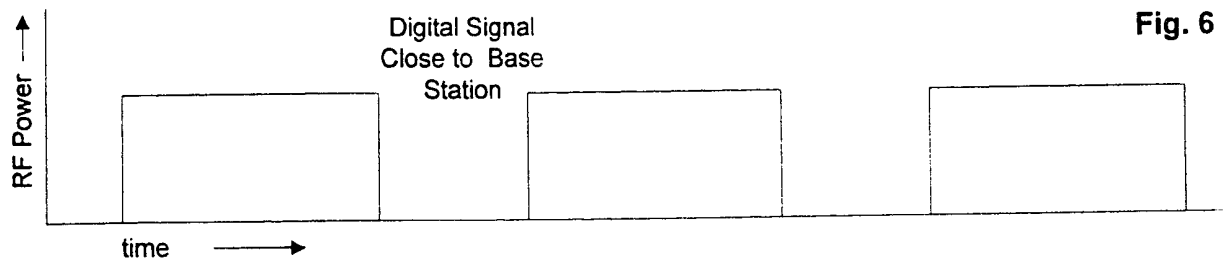
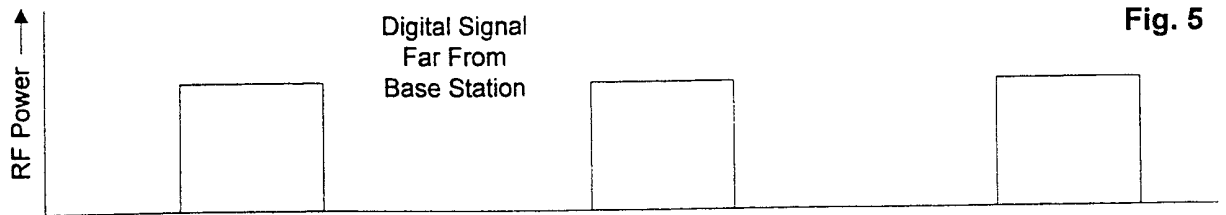
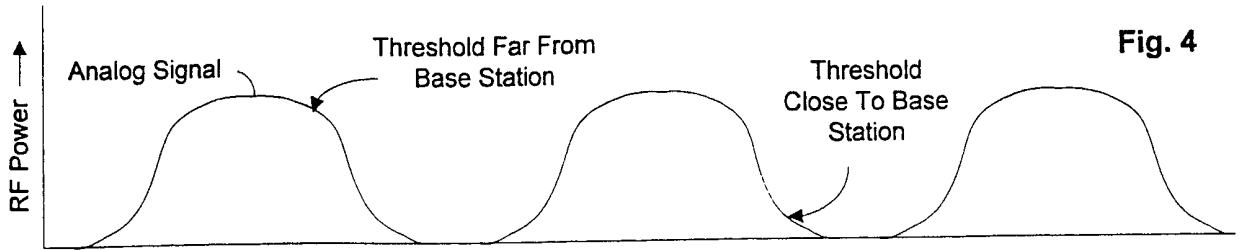

Fig. 3



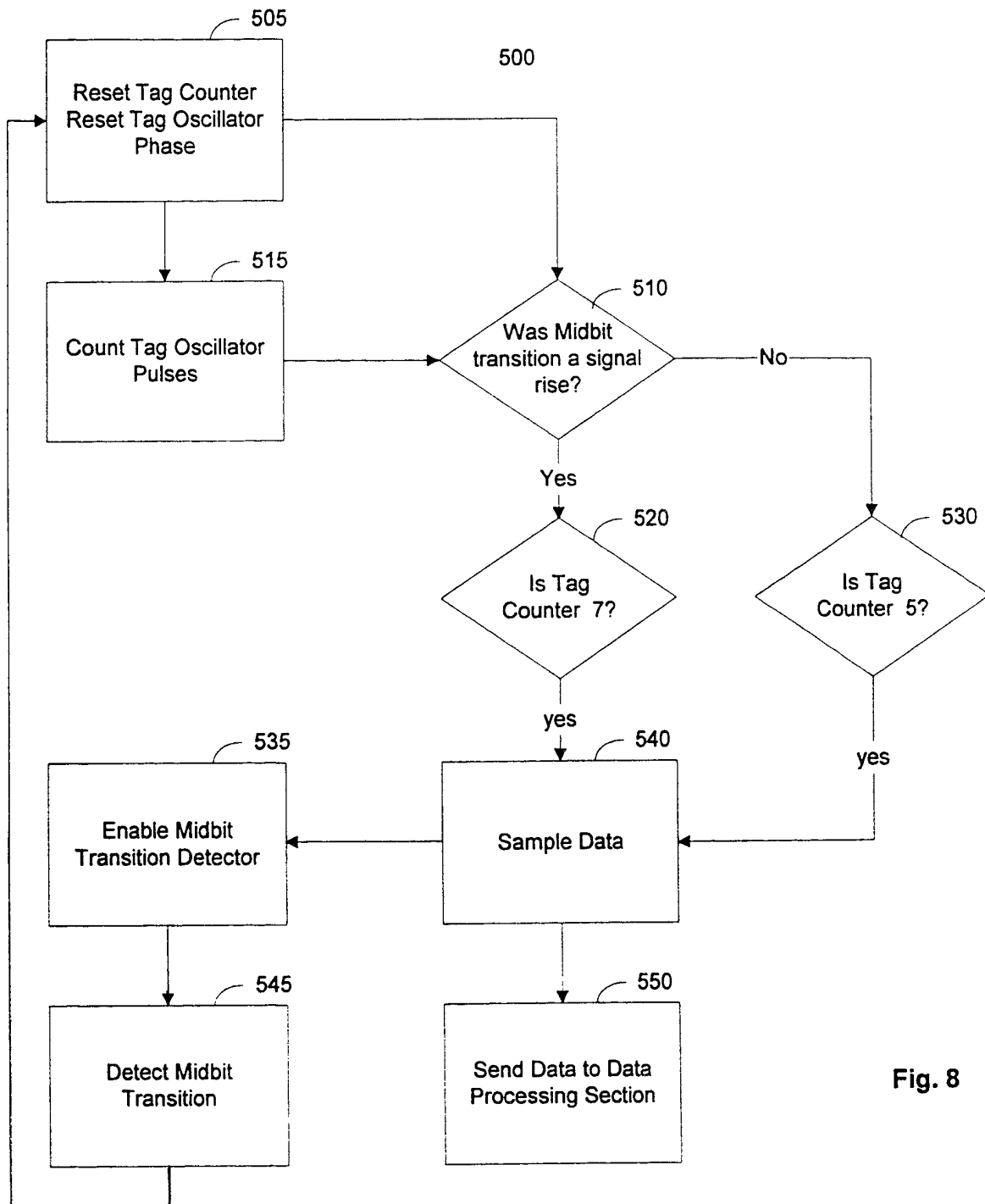

Fig. 8

INTERNATIONAL SEARCH REPORT

Internatinal Application No

PCT/US 99/15456

A. CLASSIFICATION OF SUBJECT MATTER
IPC 7 G06K19/07

According to International Patent Classification (IPC) or to both national classification and IPC

B. FIELDS SEARCHED

Minimum documentation searched (classification system followed by classification symbols)
IPC 7 G06K H04L

Documentation searched other than minimum documentation to the extent that such documents are included in the fields searched

Electronic data base consulted during the international search (name of data base and, where practical, search terms used)

C. DOCUMENTS CONSIDERED TO BE RELEVANT

Category	Citation of document, with indication, where appropriate, of the relevant passages	Relevant to claim No.
Y	US 5 726 650 A (GUNADI BAMBANG ET AL) 10 March 1998 (1998-03-10) column 3, line 40-48; claim 12; figures 1,11 column 10, line 6-18 column 13, line 4-33	1-7
Y	US 5 365 547 A (MARINARO FRANK) 15 November 1994 (1994-11-15) column 9, line 28-43; figure 8 column 27-59	1-7
A	US 4 807 260 A (SOLINA RODNEY M) 21 February 1989 (1989-02-21) column 9, line 47 -column 10, line 2; figures 1,2	7

Further documents are listed in the continuation of box C.

Patent family members are listed in annex.

Special categories of cited documents :

- "A" document defining the general state of the art which is not considered to be of particular relevance
- "E" earlier document but published on or after the international filing date
- "L" document which may throw doubts on priority claim(s) or which is cited to establish the publication date of another citation or other special reason (as specified)
- "O" document referring to an oral disclosure, use, exhibition or other means
- "P" document published prior to the international filing date but later than the priority date claimed

- "T" later document published after the international filing date or priority date and not in conflict with the application but cited to understand the principle or theory underlying the invention
- "X" document of particular relevance; the claimed invention cannot be considered novel or cannot be considered to involve an inventive step when the document is taken alone
- "Y" document of particular relevance; the claimed invention cannot be considered to involve an inventive step when the document is combined with one or more other such documents, such combination being obvious to a person skilled in the art.
- "&" document member of the same patent family

Date of the actual completion of the international search

26 October 1999

Date of mailing of the international search report

02/11/1999

Name and mailing address of the ISA

European Patent Office, P.B. 5818 Patentlaan 2
NL - 2280 HV Rijswijk
Tel. (+31-70) 340-2040, Tx. 31 651 epo nl,
Fax: (+31-70) 340-3016

Authorized officer

Cardigos dos Reis, F

INTERNATIONAL SEARCH REPORT

Information on patent family members

International Application No

PCT/US 99/15456

Patent document cited in search report	Publication date	Patent family member(s)	Publication date
US 5726650 A	10-03-1998	NONE	
US 5365547 A	15-11-1994	US 5327466 A	05-07-1994
US 4807260 A	21-02-1989	NONE	