



(51) International Patent Classification:  
A61M 1/10 (2006.01)

(21) International Application Number:  
PCT/US2014/029509

(22) International Filing Date:  
14 March 2014 (14.03.2014)

(25) Filing Language: English

(26) Publication Language: English

(30) Priority Data:  
61/793,275 15 March 2013 (15.03.2013) US

(71) Applicant: DEKA PRODUCTS LIMITED PARTNER-SHIP [US/US]; 340 Commercial Street, Manchester, NH 03101 (US).

(72) Inventors: WILT, Michael, J.; 136 Castle Hill Road, Windham, NH 03087 (US). VAN DER MERWE, Dirk, A.; 335 A Hackleboro Road, Canterbury, NH 03224 (US). DALE, James, D.; 37 White Plains Drive, Nashua, NH 03062 (US). TRACEY, Brian, D.; 151 Talent Road, Litchfield, NH 03052 (US). GRANT, Kevin, L.; 12 Burgess Drive, Litchfield, NH 03052 (US). DEMERS, Jason, A.; 387 North Bay Street, Manchester, NH 03104 (US). FLYNN, Catharine, N.; 246 Ashland Street, Manchester, NH 03104 (US).

(74) Agent: POMIANEK, Michael, J.; Wolf, Greenfield & Sacks, P.C., 600 Atlantic Avenue, Boston, MA 02210-2206 (US).

(81) Designated States (unless otherwise indicated, for every kind of national protection available): AE, AG, AL, AM, AO, AT, AU, AZ, BA, BB, BG, BH, BN, BR, BW, BY, BZ, CA, CH, CL, CN, CO, CR, CU, CZ, DE, DK, DM, DO, DZ, EC, EE, EG, ES, FI, GB, GD, GE, GH, GM, GT, HN, HR, HU, ID, IL, IN, IR, IS, JP, KE, KG, KN, KP, KR, KZ, LA, LC, LK, LR, LS, LT, LU, LY, MA, MD, ME, MG, MK, MN, MW, MX, MY, MZ, NA, NG, NI, NO, NZ, OM, PA, PE, PG, PH, PL, PT, QA, RO, RS, RU, RW, SA, SC, SD, SE, SG, SK, SL, SM, ST, SV, SY, TH, TJ, TM, TN, TR, TT, TZ, UA, UG, US, UZ, VC, VN, ZA, ZM, ZW.

(84) Designated States (unless otherwise indicated, for every kind of regional protection available): ARIPO (BW, GH, GM, KE, LR, LS, MW, MZ, NA, RW, SD, SL, SZ, TZ, UG, ZM, ZW), Eurasian (AM, AZ, BY, KG, KZ, RU, TJ, TM), European (AL, AT, BE, BG, CH, CY, CZ, DE, DK, EE, ES, FI, FR, GB, GR, HR, HU, IE, IS, IT, LT, LU, LV, MC, MK, MT, NL, NO, PL, PT, RO, RS, SE, SI, SK, SM, TR), OAPI (BF, BJ, CF, CG, CI, CM, GA, GN, GQ, GW, KM, ML, MR, NE, SN, TD, TG).

Published:

— with international search report (Art. 21(3))

[Continued on next page]

(54) Title: BLOOD TREATMENT SYSTEMS AND METHODS

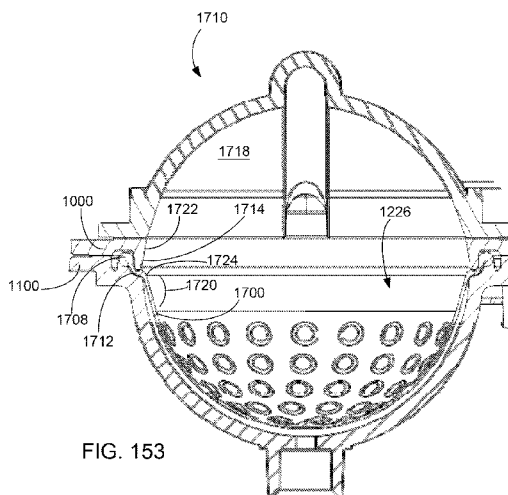

FIG. 153

(57) Abstract: The present invention generally relates to hemodialysis and similar dialysis systems, including a variety of systems and methods that would make hemodialysis more efficient, easier, and/or more affordable. One aspect of the invention is generally directed to new fluid circuits for fluid flow. According to one aspect, a blood pump is configured to pump blood to a dialyzer of a hemodialysis apparatus, the blood pump comprising a pneumatically actuated or controlled reciprocating diaphragm pump. In an embodiment, the diaphragm of the pump comprises a flexible membrane formed or molded to generally conform to a curved inner wall of a pumping chamber or control chamber of the pump, wherein the diaphragm is pre-formed or molded to have a control side taking a convex shape, so that any elastic tension on the diaphragm is minimized when fully extended into a control chamber of the pump. In another aspect, a system for monitoring the adequacy of blood flow in a blood line of the hemodialysis apparatus allows a controller to suspend dialysate pumping operations if the adequacy of blood flow in the blood line is sub-optimal, and to present information on a display on the quality of blood flow in the blood line.





---

— *before the expiration of the time limit for amending the claims and to be republished in the event of receipt of amendments (Rule 48.2(h))*

**(88) Date of publication of the international search report:**  
31 December 2014

**INTERNATIONAL SEARCH REPORT**

International application No  
PCT/US2014/029509

**A. CLASSIFICATION OF SUBJECT MATTER**  
INV. A61M1/10  
ADD.  
  
According to International Patent Classification (IPC) or to both national classification and IPC

**B. FIELDS SEARCHED**  
Minimum documentation searched (classification system followed by classification symbols)  
A61M

Documentation searched other than minimum documentation to the extent that such documents are included in the fields searched

Electronic data base consulted during the international search (name of data base and, where practicable, search terms used)  
EPO-Internal, WPI Data

**C. DOCUMENTS CONSIDERED TO BE RELEVANT**

Category*	Citation of document, with indication, where appropriate, of the relevant passages	Relevant to claim No.
X	WO 2007/120812 A2 (DEKA PRODUCTS LP [US]; KAMEN DEAN [US]; DEMERS JASON A [US]; ALTOBELLI) 25 October 2007 (2007-10-25) page 69, line 23 - page 70, line 7; figures 35c, 36-37 page 66, lines 3-8; figures 46a, 46b figures 4, 20 -----	1-24
X	US 4 222 127 A (DONACHY JAMES H ET AL) 16 September 1980 (1980-09-16) pages 1-2; figure 7 -----	1,9
X	GB 1 508 116 A (UNGER F) 19 April 1978 (1978-04-19) columns 1,2; figure 2 -----	1,9
	-/--	

Further documents are listed in the continuation of Box C.  See patent family annex.

\* Special categories of cited documents :

<p>"A" document defining the general state of the art which is not considered to be of particular relevance</p> <p>"E" earlier application or patent but published on or after the international filing date</p> <p>"L" document which may throw doubts on priority claim(s) or which is cited to establish the publication date of another citation or other special reason (as specified)</p> <p>"O" document referring to an oral disclosure, use, exhibition or other means</p> <p>"P" document published prior to the international filing date but later than the priority date claimed</p>	<p>"T" later document published after the international filing date or priority date and not in conflict with the application but cited to understand the principle or theory underlying the invention</p> <p>"X" document of particular relevance; the claimed invention cannot be considered novel or cannot be considered to involve an inventive step when the document is taken alone</p> <p>"Y" document of particular relevance; the claimed invention cannot be considered to involve an inventive step when the document is combined with one or more other such documents, such combination being obvious to a person skilled in the art</p> <p>"&amp;" document member of the same patent family</p>
---	---

Date of the actual completion of the international search  28 August 2014	Date of mailing of the international search report  17/11/2014
---	--

Name and mailing address of the ISA/ European Patent Office, P.B. 5818 Patentlaan 2 NL - 2280 HV Rijswijk Tel. (+31-70) 340-2040, Fax: (+31-70) 340-3016	Authorized officer  Westsson, David
--	---

## INTERNATIONAL SEARCH REPORT

International application No  
PCT/US2014/029509

C(Continuation). DOCUMENTS CONSIDERED TO BE RELEVANT		
Category*	Citation of document, with indication, where appropriate, of the relevant passages	Relevant to claim No.
X	EP 1 362 604 A1 (DIDECO SPA [IT] SORIN GROUP ITALIA SRL [IT]) 19 November 2003 (2003-11-19) paragraphs [0013] - [0018]; figures 3,7 -----	1,9
X	US 5 242 384 A (ROBINSON THOMAS C [US] ET AL) 7 September 1993 (1993-09-07) column 9, lines 45-65; figure 3 -----	1,9
X	WO 97/05913 A1 (MEDELA INC [US]) 20 February 1997 (1997-02-20) page 7, lines 23-35; figure 3 -----	1
A	WO 84/02473 A1 (BAXTER TRAVENOL LAB [US]) 5 July 1984 (1984-07-05) figures 19a-19c -----	1-24

# INTERNATIONAL SEARCH REPORT

International application No.  
PCT/US2014/029509

## Box No. II Observations where certain claims were found unsearchable (Continuation of item 2 of first sheet)

This international search report has not been established in respect of certain claims under Article 17(2)(a) for the following reasons:

1.  Claims Nos.:  
because they relate to subject matter not required to be searched by this Authority, namely:
  
2.  Claims Nos.:  
because they relate to parts of the international application that do not comply with the prescribed requirements to such an extent that no meaningful international search can be carried out, specifically:
  
3.  Claims Nos.:  
because they are dependent claims and are not drafted in accordance with the second and third sentences of Rule 6.4(a).

## Box No. III Observations where unity of invention is lacking (Continuation of item 3 of first sheet)

This International Searching Authority found multiple inventions in this international application, as follows:

see additional sheet

1.  As all required additional search fees were timely paid by the applicant, this international search report covers all searchable claims.
  
2.  As all searchable claims could be searched without effort justifying an additional fees, this Authority did not invite payment of additional fees.
  
3.  As only some of the required additional search fees were timely paid by the applicant, this international search report covers only those claims for which fees were paid, specifically claims Nos.:
  
4.  No required additional search fees were timely paid by the applicant. Consequently, this international search report is restricted to the invention first mentioned in the claims; it is covered by claims Nos.:

1-24

### Remark on Protest

- The additional search fees were accompanied by the applicant's protest and, where applicable, the payment of a protest fee.
- The additional search fees were accompanied by the applicant's protest but the applicable protest fee was not paid within the time limit specified in the invitation.
- No protest accompanied the payment of additional search fees.

# INTERNATIONAL SEARCH REPORT

International Application No. PCT/ US2014/ 029509

FURTHER INFORMATION CONTINUED FROM PCT/ISA/ 210

This International Searching Authority found multiple (groups of) inventions in this international application, as follows:

1. claims: 1-24

A flexible diaphragm for use in a reciprocating diaphragm pump, diaphragm configured to be interposed between the pumping chamber wall and the control chamber wall, the diaphragm comprising: a peripheral bead arranged to locate the diaphragm between the first rigid body and the second rigid body; a diaphragm body having a curved, semi-spheroid or domed shape, the diaphragm body configured to generally conform to a curved inner surface of the pumping chamber wall or a curved inner surface of the control chamber wall, and the diaphragm body having a pumping side arranged to face the inner surface of the pumping chamber wall and an opposing control side arranged to face the inner surface of the control chamber wall; a transition region between the bead and the diaphragm body, the transition region arranged to be pinched or clamped between a clamping region of the first rigid body and an opposing clamping region of the second rigid body; wherein the diaphragm is pre-formed or molded with its control side having a convex shape, such that any elastic tension in the diaphragm is reduced when the control side of the diaphragm body assumes a convex shape when positioned in the diaphragm pump.

---

2. claims: 25-66

A system for controlling fluid flow in a hemodialysis apparatus comprising: a dialysate pump configured to receive a fluid from a dialysate outlet of the dialyzer; a reciprocating diaphragm-based blood pump configured to deliver blood from an extracorporeal blood circuit to a blood inlet of the dialyzer, a pumping chamber of the blood pump separated from a control chamber of the blood pump by a flexible diaphragm, the control chamber configured to transmit positive or negative pressure to operate the diaphragm; a pressure sensor configured to measure pressure in the control chamber of the blood pump; a controller configured to receive information from the pressure sensor, and configured to control the delivery of pressure to the control chamber of the blood pump; wherein the controller is configured to cause the application of a time-varying pressure waveform on the blood pump diaphragm during a fill-stroke of the blood pump, and to monitor a pressure variation in the control chamber measured by the pressure sensor, and wherein a magnitude of the measured pressure variation that deviates from a pre-determined value causes the controller to initiate a procedure to pause or stop the dialysate pump.

---

## INTERNATIONAL SEARCH REPORT

Information on patent family members

International application No

PCT/US2014/029509

Patent document cited in search report	Publication date	Patent family member(s)	Publication date	
WO 2007120812	A2	25-10-2007	CA 2648803 A1	25-10-2007
			EP 2010247 A1	07-01-2009
			EP 2586472 A1	01-05-2013
			EP 2724736 A1	30-04-2014
			JP 5469731 B2	16-04-2014
			JP 2009533154 A	17-09-2009
			JP 2013027783 A	07-02-2013
			JP 2014167291 A	11-09-2014
			US 2007253463 A1	01-11-2007
			US 2008058697 A1	06-03-2008
			US 2008175719 A1	24-07-2008
			US 2011218600 A1	08-09-2011
			US 2013115105 A1	09-05-2013
			WO 2007120812 A2	25-10-2007
-----				
US 4222127	A	16-09-1980	NONE	
-----				
GB 1508116	A	19-04-1978	AT 344309 B	10-07-1978
			DE 2647384 A1	08-06-1977
			FR 2336117 A1	22-07-1977
			GB 1508116 A	19-04-1978
			IT 1067714 B	16-03-1985
			US 4144595 A	20-03-1979
-----				
EP 1362604	A1	19-11-2003	EP 1362604 A1	19-11-2003
			IT MI20021028 A1	14-11-2003
			US 2004001766 A1	01-01-2004
-----				
US 5242384	A	07-09-1993	NONE	
-----				
WO 9705913	A1	20-02-1997	AU 719643 B2	11-05-2000
			AU 6597596 A	05-03-1997
			CA 2229030 A1	20-02-1997
			DE 69634154 D1	10-02-2005
			DE 69634154 T2	22-12-2005
			EP 0846007 A1	10-06-1998
			EP 1498149 A1	19-01-2005
			EP 1923080 A2	21-05-2008
			JP H11510081 A	07-09-1999
			NO 981526 A	03-04-1998
			US 5776098 A	07-07-1998
			WO 9705913 A1	20-02-1997
			-----	
WO 8402473	A1	05-07-1984	AU 1449888 A	07-07-1988
			AU 2209683 A	17-07-1984
			CA 1210291 A1	26-08-1986
			DE 3378612 D1	12-01-1989
			EP 0129554 A1	02-01-1985
			ES 8500562 A1	16-01-1985
			IT 1170290 B	03-06-1987
			JP S60500159 A	07-02-1985
			WO 8402473 A1	05-07-1984
			-----	