

**(12) PATENT**  
**(19) AUSTRALIAN PATENT OFFICE**

**(11) Application No. AU 199665807 B2**  
**(10) Patent No. 702659**

(54) Title  
Apparatus and method for TV broadcast copy protection

(51)<sup>6</sup> International Patent Classification(s)  
H04N 007/088 H04N 007/52  
G11B 015/04 H04N 007/64  
G11B 027/36

(21) Application No: 199665807 (22) Application Date: 1996 .09 .24

(30) Priority Data

(31) Number	(32) Date	(33) Country
P07-276931	1995 .09 .29	JP

(43) Publication Date : 1997 .04 .10

(43) Publication Journal Date : 1997 .04 .10

(44) Accepted Journal Date : 1999 .02 .25

(71) Applicant(s)  
Sony Corporation

(72) Inventor(s)  
Masaki Oguro; Keiji Kanota; Yukio Kubota

(74) Agent/Attorney  
SPRUSON FERGUSON,GPO Box 3898,SYDNEY NSW 2001

(56) Related Art  
EP 580367  
EP 581227  
EP 574892



AU9665807

**(12) PATENT ABSTRACT (11) Document No. AU-A-65807/96**  
**(19) AUSTRALIAN PATENT OFFICE**

- (54) Title  
**APPARATUS AND METHOD FOR TV BROADCAST COPY PROTECTION**
- (51)<sup>s</sup> International Patent Classification(s)  
**H04N 007/088 G11B 015/04 G11B 027/36 H04N 007/52**  
**H04N 007/64**
- (21) Application No. : **65807/96** (22) Application Date : **24/09/96**
- (30) Priority Data
- (31) Number (32) Date (33) Country  
**7-276931 29/09/95 JP JAPAN**
- (43) Publication Date : **10/04/97**
- (71) Applicant(s)  
**SONY CORPORATION**
- (72) Inventor(s)  
**MASAKI OGURO; KEIJI KANOTA; YUKIO KUBOTA**
- (74) Attorney or Agent  
**SPRUSON & FERGUSON , GPO Box 3898, SYDNEY NSW 2001**
- (57)

Copy protecting television broadcast program signals which are received and recorded in a format that reserves recording areas for accessory information relating to the format and reserves other recording areas for digital image signals. When the input signals received for recording are determined to be television broadcast program signals, a generation limiting signal inserted therein is set to a copy protect state and is recorded to inhibit copying.

Apparatus and Method for TV Broadcast Copy Protection

**ABSTRACT OF THE DISCLOSURE**

Copy protecting television broadcast program signals which are received and recorded in a format that reserves recording areas for accessory information relating to the format and reserves other recording areas for digital image signals.

5 When the input signals received for recording are determined to be television broadcast program signals, a generation limiting signal inserted therein is set to a copy protect state and is recorded to inhibit copying.

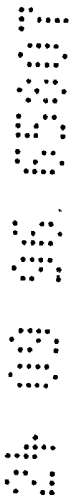

S & F Ref: 354318

**AUSTRALIA**  
**PATENTS ACT 1990**

**COMPLETE SPECIFICATION**

**FOR A STANDARD PATENT**

**ORIGINAL**

---

Name and Address  
of Applicant: Sony Corporation  
7-35, Kitashinagawa 6-Chome  
Shinagawa-Ku  
Tokyo  
JAPAN

Actual Inventor(s): Masaki Oguro, Keiji Kanota and Yukio Kubota

Address for Service: Spruson & Ferguson, Patent Attorneys  
Level 33 St Martins Tower, 31 Market Street  
Sydney, New South Wales, 2000, Australia

Invention Title: Apparatus and Method for TV Broadcast Copy Protection

The following statement is a full description of this invention, including the best method of performing it known to me/us:-

APPARATUS AND METHOD FOR TV BROADCAST COPY PROTECTION

BACKGROUND OF THE INVENTION

The present invention relates to recording and reproducing a digital picture signal and, more particularly, to copy protecting television broadcast programs recorded and reproduced as a digital picture signal.

Television broadcast programs are recorded and played back by a viewer using a video tape recorder (VTR). The VTR may be an analog VTR, but analog technology cannot record a TV program with high image quality and, as a result, the reproduced analog TV broadcast program has a lower image quality than the originally broadcast TV program.

A commercially available digital VTR, on the other hand, offers high image recording quality. With the digital VTR, therefore, the reproduced TV program has virtually the same image quality as the originally broadcast TV program.

Copyright protection of video programs on video tape is available in both analog and digital VTRs. In the analog VTR, a copyright protection signal is inserted into the blanking interval of the pre-recorded analog video signal. The copyright protection signal prevents the analog VTR from copying a copyright protected analog video program from a commercially available analog video tape. The digital VTR provides a Serial Copy Management System (SCMS) to copyright protect a digital video program on a digital video tape. A form of the SCMS

15  
20

copyright protection system has been used to prevent copying of  
audio data recorded on a Digital Audio Tape (DAT). The SCMS  
technique restricts copying, but is limited to copy protecting  
output digital signals and is ineffective if those digital  
5 signals are converted to analog form.

Problematically, the above-described copy protection  
techniques can be circumvented. If a digital VTR inserts a  
copyright protection code into the digital video data to prevent  
another digital VTR from copying the digital video program, the  
10 conversion of the digital video program to analog form could  
defeat such protection. An analog VTR does not recognize the  
digitally recorded copyright protection signal. By obtaining the  
analog video program from analog output terminals of the digital  
VTR, therefore, the above copyright protection schemes are  
circumvented. Worse, since the unauthorized copy is made from  
the high image quality reproduction of the digital VTR, an  
unauthorized high image quality copy is produced.

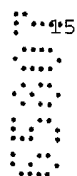

25

A technique for protecting a copyrighted program for  
use in a digital VTR has been described in Japanese Patent  
Applications Nos. 5-277633 and 6-82576. According to the  
proposed technique, a video signal is recorded with a copyright  
protection signal inserted into a line of the video signal  
together with data that specifies which line contains the  
protection signal. A parameter for coding the copyright  
protection signal is recorded in a data pack. However, the

proposed technique does not copyright protect TV broadcast signals.

OBJECTS AND SUMMARY OF THE INVENTION

It is, therefore, an object of the invention to provide  
5 copyright protection of a TV broadcast program.

It is a further object of the invention to provide  
copyright protection of a TV broadcast program recorded by a  
digital VTR which is effective even if the digitally recorded  
program is reproduced by another digital VTR or by an analog VTR  
10 coupled thereto through a digital interface or by a digital VTR  
having an analog video output.

In accordance with the above objectives, a copy  
protection method and apparatus are provided for copy protecting  
a television broadcast program that is to be recorded in a  
digital format that reserves recording areas for accessory  
15 information concerning the structure of the tape format and for  
the input image signal. When the input signal is determined to  
be a television broadcast program, a generation limiting signal  
is set to a copy protect state and inserted into the received  
20 signal for recording therewith. Preferably, this generation  
limiting signal is recorded in a pack with the accessory  
information. If the digitally recorded television signal is  
reproduced and supplied as an output analog signal, the  
generation limiting signal is used to insert a copy protect  
25 signal into the analog output.

BRIEF DESCRIPTION OF THE DRAWINGS

The above objects, features and advantages of the present invention will become apparent from the following detailed description of illustrative embodiments which is to be considered in connection with the accompanying drawings, in which:

Fig. 1 is a diagram of the tape format of one track in a digital VTR to which the present invention applies;

Fig. 2 is a diagram showing a structure of the ITI area shown in Fig. 1;

Fig. 3 is a diagram showing the data structure of a track defined by an application ID (APT);

Fig. 4 is a diagram showing the application ID (APT) structure;

Figs. 5A and 5B are diagrams showing data structures on a track when APT = 000;

Fig. 6 is a diagram showing the structure of pack data;

Fig. 7 is a diagram showing an hierarchical structure of a header;

Fig. 8 is a table showing the summary of a pack header;

Fig. 9 is a diagram showing the PC1 data structure of a source control pack;

Fig. 10 is a diagram showing the structure of an audio sector;

Figs. 11A and 11B are diagrams showing the pre-SYNC and post-SYNC bytes of an audio sector;

Figs. 12A and 12B are diagrams showing a SYNC block and a framing format of the audio sector;

5 Fig. 13 is a table for describing 9 packs of the audio data along a track;

Fig. 14 is a diagram showing the content of an AAUX SOURCE CONTROL pack;

10 Fig. 15 is a diagram showing the definition of a VAUX SOURCE CONTROL pack;

Fig. 16 is a diagram showing the structure of VBID with a 2-bit CGMS;

Figs. 17A and 17B are graphs showing a VITS signal;

Fig. 18 is a diagram showing the VITS signal;

15 Fig. 19 is a flowchart implementing an embodiment of the present invention;

Fig. 20 is a block diagram of a recording circuit including the present invention;

20 Fig. 21 is a block diagram of a VAUX recording circuit included in the recording circuit of Fig. 20;

Fig. 22A and 22B are diagrams showing main and optional areas for VAUX data;

25 Fig. 23 is a block diagram showing a VAUX pack data generator;

Fig. 24 is a diagram showing the data content for the main area of the VAUX pack data;

Fig. 25 is a block diagram showing an AAUX pack data generator;

5 Fig. 26 is a diagram showing the data content for the main area of the AAUX pack data;

Fig. 27 is a block diagram of a MIC microcomputer;

Fig. 28 is a block diagram of a TV signal determining circuit;

10 Fig. 29 is a block diagram of a portion of a reproducing circuit which incorporates the present invention;

Fig. 30 is a block diagram of another portion of the reproducing circuit intended to be coupled to Fig. 29;

15 Fig. 31 is a block diagram of a VAUX detector provided in the reproducing circuit;

Fig. 32 is a block diagram of a VAUX reproducing circuit intended to be coupled to Fig. 31; and

Fig. 33 is a block diagram of a digital copying circuit.

20 DETAILED DESCRIPTION OF THE PREFERRED EMBODIMENTS

Referring now to the drawings, wherein like reference numerals designate identical or corresponding parts throughout the several views, the present invention will now be described.

Tape Format

Before describing the present invention, reference is made to the format in which digital video signals are recorded on tape. The digital VTR records tracks using a helical recording technique, wherein a rotary magnetic head spins at an angle to the video tape which travels along a head scan direction. The resulting track pattern has tracks arranged at a slant along the tape medium (not shown). An example of the format for a track is shown in Fig. 1, wherein the track begins and ends with margins (1250 bits) that define the data area. Insert and Track Information (ITI) is provided at the beginning of each track and includes timing information representing the position of the audio, video and subcode areas within the track. Inter-Block Gaps (IBG1, IBG2, IBG3) segregate the audio, video and subcode areas of the track. An audio area of 10500 bits provides for audio data storage followed by a video area of 111,750 bits for video data storage, and, then, by a subcode area of 1200 bits for the subcode area. Pre-ambls and post-ambls bound the audio, video and subcode areas. For a 525 line/50 Hz VTR system, 10 such tracks are used to record a single video frame (including audio data) of an audio/video program, which 12 tracks accommodate a 625 line/60 Hz system.

The ITI is a header of the track and includes information for aligning the audio, video and subcode data within that track for after recording operations. As shown in Fig. 2,

15  
20  
25

the ITI area begins with a preamble which is comprised of 1400 bits used as a run-in for the magnetic head of the VTR. The preamble is followed by a Start Sync Block Area (SSA) comprised of 1830 bits with 61 sync blocks (30 bits apiece) therein. These  
5 sync blocks contain synchronizing information which is useful for timing the audio, video and subcode areas of each track. When audio copying or re-recording is performed, for example, the sync block containing the timing information for the audio area is detected from the SSA and the position of the desired audio area  
10 can be determined therefrom.

It will be appreciated that it is difficult to keep the magnetic head of the VTR in contact with the inlet side of each track because of mechanical limitations, making scanning of the inlet side of each track unstable. This is true for the ITI area which is placed near the inlet of each track. To enhance the sensing probability of the sync blocks, the length of the sync blocks is shortened and the number of sync blocks is increased.

Following the SSA are 90 bits of a Track Information Area (TIA) formed of three blocks which, as will be explained in more detail, store information about the track. Each block includes an Application ID of a Track (APT) (three bits) including an SP/LP bit which indicates track pitch; a reserve bit; and a Pilot Frame (PF) bit which represents a reference for the servo system. The TIA is followed by the postamble composed of 280 bits which is used to provide a margin for the ITI area.

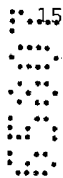

The track in Fig. 1 includes audio, video and subcode areas; but each track may contain n data areas such as shown in Fig. 3. The ITI indicates where these areas begin/end and the digital VTR employs the ITI to quickly find and retrieve the desired area (AREA 1, AREA 2, AREA 3). An application ID may be provided for each area.

The application ID (APT) stored in the TIA designates the different areas as being video, audio or sub-code areas. The application ID (APT) preferably is arranged as an hierarchy of application IDs as shown in Fig. 4. With such an hierarchical structure, whole branches of data including several areas of the hierarchical "tree" can be extracted by the digital VTR. Thus, newly defined data areas may be accommodated by this hierarchical structure.

In addition to storing this hierarchical structure in the TIA of the tape, an hierarchy may be stored in a memory IC (MIC) of the tape cassette that is used with the digital VTR. The MIC can be employed to store information relating to all of the recorded programs on the video tape to assist the VTR in recording and reproducing the data from a newly loaded record medium. For example, the MIC can be used to mark a predetermined program, designate the reproduction order of programs, designate a predetermined scene for reproducing a still image (i.e., a photo), reserve a timer record operation, etc.

The application ID of the MIC (APM) is shown in Fig. 4 and may occupy the high order 3 bits of address 0. In a similar manner to the hierarchical structure of Application ID of the tracks (APT), the APM determines the data structure of the MIC.  
5 Japanese Patent Applications 5-277633 and 6-82576 describe an MIC which may be used for this purpose.

It will be appreciated that the application ID is not an ID for defining an application of the digital VTR, but is an ID for defining the data structure of an area of the record  
10 medium. That is, the application ID (APT) stored in the TIA defines the data structure on the track, and the application ID (APM) of the MIC defines the data structure of the MIC.

As an example of the application ID (APT) defining the data structure of different areas of the track, reference will be made to Figs. 5A and 5B. When the application ID (APT) is set = 000, the track is arranged as shown in Fig. 5A with three areas (AREA1, AREA2 and AREA3). The application IDs (AP1, AP2, AP3) are stored in each respective area and contain information on the arrangement of the data within the respective area. For example,  
15 when the information in the AP1 is set = 000, the data structure of AREA1 is an audio data structure which includes Audio Accessory Data (AAUX); when the information in AP2 is set = 000, the data of AREA2 is video data which includes Video Accessory Data (VAUX); and, when AP3 is set = 000, the data of AREA3 is subcode data. It will be appreciated that configuring the  
20  
25

application ID for the three areas AP1, AP2 and AP3 = 000  
corresponds to a configuration for commercial use. Thus, the  
three areas (AREA1, AREA2, AREA3) shown in Fig. 5A are designated  
as audio, video and subcode areas, respectively, as shown in Fig.  
5 5B. Of course, any digital representation for an application ID  
can be used to indicate the data structure. Also, the  
application ID (APM) may be of a similar structure.

With the specific format set by the application ID  
(APT), the digital VTR records the different data (audio, video,  
10 subcode) onto the record medium. The actual AAUX, VAUX and  
subcode data are recorded in the areas (AREA 1, AREA 2, AREA 3)  
as a plurality of structures called packs having the common pack  
structure shown in Fig. 6. As shown, a pack is composed of 5  
bytes (PC0 ... PC4) with the high order byte reserved as a header  
15 (PC0) and the 4 lower bytes reserved for data.

The header is divided into the hierarchical structure  
shown in Fig. 7. The high order or upper 4 bits of the header  
(PC0), for example, serve as an upper header and the lower order  
4 bits of the header serves as a lower header in the hierarchical  
20 structure shown in Fig. 7. The hierarchy can be expanded to  
further lower levels by using the bits in the lower header. With  
this arrangement, it is possible to clearly systemize the content  
of each pack and easily expand the packs. When the pack header  
is represented by a table, for example, the 8 bits of the pack  
header can represent 256 different pack structures.





"0011" (B-Y), red (R) "0101", green (G) "0110", and blue (B) "0111".

It will be noted that large items "1001" to "1110" in Fig. 8 are reserved for additional data. Items which are  
5 undefined, for example, may be coded as the reserved large items, thus defining new definitions for optionally recording new data in the future.

An example of the source control pack for either the AUUX or VAUX indicated by the source control large item "0000" is  
10 shown in Fig. 9 as data area PC1 of the pack of Fig. 6. Serial Copy Management System (SCMS) data is stored in the first two bits of PC1 which determine the copy protection of the recorded video program; copy source data is stored in the next two bits which determine the source of the data to be copied; copy  
15 generation data is stored in the following two bits; cipher type is stored in the next bit; and cipher data is stored in the least significant bit (LSB).

As shown in Fig. 13, packs are arranged within a track in a grid with, for example, each of the packs (0 ... 8)  
20 corresponding to an AAUX pack. Each data pack is fixed in length to 5 bytes. However, when data is written to the MIC, the pack structure has a variable length such that the MIC can be filled to capacity to obtain the most efficient use of the MIC.

The audio data is stored in an audio sector on the record medium in the arrangement shown in Fig. 10 including a  
25

preamble, an audio area and a postamble. The video data is stored in an analogous video sector. The preamble includes a run-up of 400 bits for synchronizing a PLL followed by 100 bits of pre-sync information used for pre-detection of the audio sync blocks in the audio area. The audio area stores the audio data and is composed of 14 audio sync blocks (10,500 bits). The postamble includes 50 bits of a post-sync block used to definitively mark the end of the audio sector followed by 500 bits of a guard area to prevent after-recorded audio data from overlapping into the next video sector.

The pre-sync and the post-sync blocks are shown in more detail in Figs. 11A and 11B, respectively. The pre-sync block is shown as having 6 bytes, including an SP/LP byte, which indicates a standard-play (SP) or a long-play (LP) mode. Notably, the SP/LP byte is omitted from the post-sync block of Fig. 11B. When the SP/LP block is set = FFh, for example, the SP mode is indicated; and, when the SP/LP is set = 00h, the LP mode is indicated. It will be appreciated that the SP/LP byte is stored as an SP/LP flag in the TIA area of the ITI and is stored in the pre-sync block as a back-up in case the TIA area cannot be read. The remainder of the pre-sync and post-sync blocks contain two sync bytes, followed by three identification bytes (ID0, ID1 and IDP).

The bit lengths for the pre-sync and post-sync blocks are calculated as follows. The pre-sync block has 6 bytes (Fig.

11A) with 8 bits in each byte making a total of 48 bits. The pre-sync block is converted from 24-bit data into 25-bit data by a 24 to 25 conversion, thus a 25/24 conversion factor factoring 48 bits = 50 pre-sync bits. There are two pre-sync blocks, resulting in  $6 \times 2 \times 8 \times 25 \div 28 = 100$  bits. There is only one post-sync block having the same overall structure resulting in  $6 \times 1 \times 8 \times 25 \div 24 = 50$  bits.

The audio sync blocks are collected and recorded on the record medium in the audio area (Fig. 5B) in groups of 14 sync blocks per track as shown in Fig. 12A. The first nine audio sync blocks (0 ... 8) contain the audio data, whereas the last five sync blocks are reserved for parity information. Five bytes of each audio sync block are reserved for the AAUX pack, two bytes of the sync block are reserved for sync bytes, and three bytes of the sync block are reserved for ID bytes, all as shown in Figs. 12A and 12B. Recalling that the digital VTR performs a "24 to 25" conversion prior to the recording of the digital signal, the total bit length of the group of 14 sync blocks per track is 90 bytes per audio sync block (Fig. 12B)  $\times$  14 audio sync blocks  $\times$  8 bits per byte  $\times$  25/24 conversion factor = 10,500 bits.

The audio area of Fig. 12A preferably includes the parity sectors C1 and C2. The parity sector C1 occupying the last 8 bytes of each audio sync block is known as horizontal parity because C1 assists the digital VTR in detecting areas in the data of the respective audio sync blocks. The parity sector

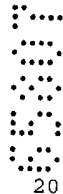

C2 occupying the last 5 audio sync block positions of Fig. 12A, on the other hand, is known as a vertical parity because C2 assists the digital VTR to determine what will be seen as vertical errors in all the sync blocks.

5           The digital VTR records the AAUX data as data packs onto the record medium in the manner shown in Fig. 13. Each of the pack numbers (0 ... 8) in Fig. 13 represents the AAUX packs (0 ... 8) in Fig. 12A, and packs (0 ... 8) are comprised of pack headers 50 to 55 (hexadecimal) and optional packs (a ... g). It  
10 will be appreciated that AAUX packs, such as shown in Fig. 12A, are written ten times over ten tracks to ensure that the information in each data pack is recovered during a reproducing operation even if a portion of the data is lost due to a mechanical failure. By writing the pack data repeatedly over ten  
15 tracks, recovery of the AAUX data is ensured even if a portion of the record medium is corrupted.

          The optional packs are also written ten times. However, the number of total optional packs changes with the video system. In the 525/60 VTR system of Fig. 13, for example,  
20 30 optional packs are recorded in a video frame and, therefore, three optional packs are recorded in each track over ten tracks. On the other hand, in a 625/60 VTR system, 36 optional packs are recorded. It will be appreciated that the optional packs are truly optional and may, or may not, be selected among the types of data shown by the pack header table in Fig. 8.

In Japanese Patent Application 6-19991, a method for packing data retrieved from the vertical blanking interval (VBID) is described. There, the packed data is restored in the vertical blanking interval during playback; and during recording the picture data is recorded but the vertical blanking interval is discarded.

The main area data blocks (50 ... 55) store essential information about the audio data, such as a sampling frequency for reconstructing the audio signal and the number of quantizing bits in each sample, for example. Normally, these packs are linked in sequence, but may also be linked in another order. In Fig. 13, for example, the audio packs are linked in the direction of the arrows forming the sequence (a, b, c, 50, 51, 52, 53, 54, 55). Japanese Patent Application 6-19991 describes restoring the VBID data from the packs indicated by pack headers 61h and 51h of the main area data packs.

An example of a data pack configured as an AUUX pack is shown in Fig. 14. The pack header (PC0) includes a large item "0101" indicating an AAUX pack according to the pack header table (Fig. 8). Byte PC1 includes copy generation information including two bits of SCMS code (Fig. 9) incorporating copy generation limiting signals (CGMS). The individual bits of the SCMS code represent the CGMS information shown in Fig. 9 and indicate whether the corresponding audio data is copyrighted. The two-bit combination of the SCMS bits represents SCMS

information for managing the CGMS information. The specific designations shown in Fig. 9 are reproduced here for convenience.

5           Upper CGMS bit;     0 = not copyrighted  
                                  1 = copyrighted

          Lower CGMS bit;     0 = original  
                                  1 = not original

10          SCMS Combination;  00 = freely copied  
                                  01 = not used  
                                  10 = one copy allowed  
                                  11 = copying prohibited

15          For example, the CGMS bits "10" read from an AAUX pack indicate  
          that one copy of the copyrighted, original audio track is  
          allowed. Then, the CGMS data is rewritten in the pack PC1 to  
          "11" to prohibit further copying. The AAUX pack of Fig. 14  
          includes in byte PC4 a record inhibit (RI) bit to inhibit or  
20          allow copying of the corresponding audio data.

          The video data is stored in sync blocks of a video  
          region in a similar fashion to the audio region shown in Fig. 10.  
          Similar to the audio region, the video region includes a  
          preamble, a video area and a postamble. Since video data is more  
          comprehensive than audio data, however, more video sync blocks  
25

(i.e., bytes per video sync block) are used by the video region than by the audio region. Specifically, the video area is formed of 111,750 bits (versus 10,500 bits of the audio area) and the video guard area is formed of 925 bits (versus 500 bits of the audio guard area). The guard area of the video data is larger than in the audio data because video data tends to be larger than audio data and more guard bits are preferred to ensure that the video data does not overlap into adjoining areas of the record medium. The video sync blocks of the video sector may also include the parity portions C1 and C2, similar to that shown in Fig. 12A.

A data pack configured as a VAUX source control pack, for example, is shown in Fig. 15. Similar to the AAUX source control pack of Fig. 14, the VAUX source control pack includes a pack header with a large item "0110" indicating VAUX data; copy generation limiting signals in byte PC1; and a recording inhibit bit (RI) in byte PC4.

Subcode data is also recorded on the record medium in a data pack arrangement. The subcode region includes 1200 bits of a preamble, 1200 bits of a subcode area and 1325 (or 1200) bits of a postamble. Unlike the audio and video regions, the preamble of the subcode region does not have a pre-sync block and the postamble of the subcode region does not have a post-sync block. This is because the subcode region is frequently rewritten for indexing during a search, and updating the pre-sync and post-sync

blocks each time during the search is time consuming. The  
subcode area preferably contains 12 subcode sync blocks with each  
subcode sync block including 5 pre-sync bytes; 5 data bytes of  
auxiliary data; and 2 parity bytes C1 as shown in Fig. 12A, thus  
5 forming a 12-byte sync block.

The CGMS data of the AAUX and VAUX source control packs  
(Figs. 14, 15) is extracted therefrom and directly copied into  
the vertical blanking interval data (VBID) of the digital video  
signal shown in Fig. 16. As shown, the CGMS bits are inserted  
10 into BIT 7 and BIT 8 of the data section of the VBID. It will be  
noted that the VBID also includes WIDE ID data (bits 1 and 2)  
including a transmission aspect ratio (BIT 1) and a picture  
display format (BIT 2); a MODE ID (bits 3-6) for indicating the  
mode of the video signal; data bits 7-14; and CRCC information in  
15 bits 15-20.

#### CGMS Retrieval/TV Broadcast Detection

20  
25  
The present invention initially determines whether a  
video signal is a TV broadcast signal and, if so, retrieves the  
CGMS data from the AAUX, VAUX control source packs (Figs. 14,  
15). To identify a TV broadcast signal, the present invention  
senses signals which are indicative of the TV broadcast signal  
such as the Video Interval Test Signal (VITS) shown in Figs. 17A  
and 17B; or the Video Interval Reference Signal (VIR) shown in  
Fig. 18. The VITS or the VIR signals are provided with the TV  
broadcast signal and, therefore, identifying these signals

determines that the incoming video signal is a TV broadcast  
signal. It will be noted that the VITS signal is inserted in  
both the first and second field of a frame, as shown in Figs.  
17A, 17B, respectively. The VITS signal is inserted on line 17  
5 of both fields in the CCIR 473 standard of the transmitted TV  
broadcast signal, and in the United States, the VITS signal is  
inserted on lines 17 and 18 because the TBC transmission in the  
United States may cause the VITS signal to be shifted by one  
line. Accordingly, the present invention searches a range of  
10 lines 16, 17 and 18 to identify the VITS signal and thereby  
detect the TV broadcast signal.

It will be appreciated that, unlike the digital VTR,  
the analog VTR records the VITS or VIR signal along with the TV  
broadcast signal because the analog VTR, unlike the digital VTR,  
15 does not cut off the vertical blanking interval.

Problematically, such an analog recorded TV broadcast signal  
would be presented as an original TV broadcast signal (as opposed  
to a copy) to the present invention. Fortunately, the analog VTR  
cannot sense the high frequency, generally several Mhz, of the  
VITS or VIR signals. Consequently, the analog VTR smooths the  
20 high frequency VITS and VIR signals and the present invention  
does not erroneously detect a TV broadcast signal therefrom.  
Even if the present invention senses erroneously that the analog  
VTR output signal is an original TV broadcast signal, the present  
invention treats analog output signals as if they automatically  
25

have a copyright, and the analog output signal does not pose a problem to the present invention.

It will also be appreciated that video signals pre-recorded on magnetic tape or disk also contain the VBID signal or  
5 a copy-protect signal. The present invention treats such pre-recorded signal as original TV broadcast signals and automatically copyright protects those signals.

As shown in Fig. 19, the present invention when incorporated into a digital VTR, detects a TV broadcast signal  
10 and sets the CGMS therefrom. That is, when an analog video signal (composite video signal) is input, whether the present invention senses a copy-protect signal (such as the type used by Macrovision) is present in the input analog video signal in  
15 inquiry S1. If so, it is assumed the input video signal is a copy and further copying is prohibited by setting the CGMS = "11" in instruction S2 (see Fig. 9).

But when no copy-protect signal is detected, the routine advances to inquiry S3 to determine if a VBID signal is present in the input analog video signal. If the VBID signal is detected, the routine determines that the input video signal is received directly from a television broadcaster, and is not pre-recorded or copied, for example. At this time, the routine advances to inquiry S7 to determine whether the received video signal is to be supplied to an analog video output or to a  
20 digital VTR output of the digital VTR. If the video signal is to  
25

be supplied to the analog video output, the routine extracts the CGMS data directly from the analog video output in step S8; otherwise the CGMS is set according to the predetermined values shown in step S9 if the video signal is to be supplied to the  
5 digital VTR output.

If neither a copy-protect signal nor a VBID signal are detected, the routine advances to inquiry S4 to determine whether a VITS signal is present in the input analog video signal. If so, the routine allows the corresponding input analog video  
10 signal to be copied once by setting the CGMS bits = "10" (see Fig. 9).

When the copy-protect signal, the VBID signal and the VITS signal are not detected, the routine advances to step S6, meaning that the input analog video signal is not a copyrighted  
15 signal. In this instance, the routine sets the CGMS data = "00" in step S6, indicating that the input analog video signal is not copyrighted, thereby allowing another VTR to copy the input analog video signal freely, whether this video signal is supplied to the analog output terminal or to the digital VTR output  
20 terminal.

In step S9, the routine responds to the CGMS bits to establish whether copying is allowed, once allowed or inhibited entirely. In the example of Fig. 19, when CGMS is set to "00", the copy-protect signal, the VBID signal and the VITS signal were  
25 not sensed and recording is allowed. When the CGMS is set to

"10", the VITS signal was sensed and one copy is allowed; hence, the CGMS is set to "11" after recording is permitted so as to prohibit another generation. When the CGMS = "11", the present invention inhibits copying entirely.

5

Recording Circuit

A recording circuit according to the present invention is shown in Fig. 20, wherein a TV broadcast signal is received by a tuner 2, via antenna 1, where it is restored into a composite video signal and an audio signal. The restored video signal is switched through a switch 3a that switches between the restored video signal and an external analog video input signal that may be supplied to input terminal 4, to a Y/C separating circuit 6. The Y/C separating circuit separates the luminance (Y) signal from the chrominance (R-Y, B-Y) signals in the restored video signal. The separated signals are low pass filtered by low pass filters (LPF) 7a, 7b and 7c and, then, digitized by analog-to-digital converters 8a, 8b and 8c. A blocking circuit 9 forms the digitized data into blocks and a shuffling circuit 10 shuffles the blocks in preparation for data compression and coding performed by a data compressing/coding section 14. The coded data, then, is formed into sync blocks by framing circuit 15, with VAUX data added thereto by an adding circuit 16 from a VAUX circuit 17, thereby forming the VADATA output.

10

15

20

25

The video signal provided by switch 3a is coupled to a sync separating circuit 11 which separates the horizontal and

vertical synchronizing signals. The separated synchronizing signals are supplied to a phase locked loop (PLL) circuit 12 to generate a clock signal on the order of about 13.5 MHz. This clock signal is supplied to A/D converter 8a as a sampling signal and is frequency divided in divider 13 by a factor of 2 or by a factor of 4 to be supplied to A/D converters 8b and 8c as a sampling signal. It will be appreciated that the luminance (Y) and the chrominance (R-Y, B-Y) components are in proportioned amounts corresponding to the 4:2:2 video format, wherein four pixels of luminance (Y) data are transmitted with two pixels of color difference (R-Y) data and two pixels of color difference (B-Y) data. Here, the 4:2:2 video format is sampled by using a 13.5 MHz sampling frequency to sample the luminance signal (Y) and half of that sampling frequency to sample the chrominance (R-Y, B-Y) signals.

It will be appreciated that a 4:1:1 signal of the NTSC system of 525 lines/60 Hz may be sampled, wherein the luminance signal (Y) has four pixels for every pixel of color difference signals (R-Y), (B-Y). Similarly, a 4:2:0 signal in the PAL system of 625 lines/50 Hz, may be sampled.

As an example of the frequencies of the separated luminance and chrominance signals produced by Y/C separating circuit 6, the luminance signal (Y) may have a maximum frequency of about 5.75 Mhz and the color difference signals (R-Y, B-Y) may have maximum frequencies of about 2.75 Mhz for one type of

format; and the luminance signal (Y) may have a maximum frequency  
of about 5.75 Mhz while the color difference signals may have a  
maximum frequency of about 1.4 Mhz. It will be noted that the  
low pass filters of Fig. 20 are designed with such cut-off  
5 frequencies.

The blocking circuit 9 forms the digitized samples  
into, for example, 8 x 8 (samples x lines) blocks. The shuffling  
circuit 10 shuffles these blocks to effectively disperse the data  
in case data is lost due to head clogging or horizontal  
10 impairment of the magnetic tape. The compressing and coding  
section 14, which compresses and codes the shuffled blocks,  
includes a compression unit for compressing the blocks using  
discrete cosine transform (DCT) or variable length coding (VLC);  
an estimator unit for estimating the amount of compressed data;  
15 and a quantizing circuit to quantize the compressed data blocks  
with quantization co-efficients that are adjustable by the  
estimator unit. The quantized data are formed into frames of  
sync blocks by framing circuit 15 and the VAUX data supplied from  
VAUX circuit 17 is inserted into the frame by adding circuit 16,  
20 thereby producing output video data (VDATA).

The audio signal provided at tuner 2 is sent to a  
switch 3b, which selectively switches between the restored audio  
signal and an external analog audio signal. The selected audio  
signal is digitized by an analog-to-digital conversion circuit  
25 21, a shuffling circuit 22 shuffles the digitized audio signal,

and a framing circuit 23 forms frames of sync blocks, each sync block containing the shuffled audio data. AAUX data generated by AAUX circuit 19 is added to a frame by adding circuit 24 to produce output audio data (ADATA).

5           The VAUX and AAUX data are generated essentially by a mode processing microcomputer 34. The mode processing microcomputer interfaces with a mechanical control microcomputer 28 that controls the mechanical operations of the VTR. For example, when a user selects a special playback mode, such as  
10 fast forward, the mechanical control microcomputer controls the speed of the tape to correspond to the fast/forward mode.

A signal processing microcomputer 20 generates absolute track numbers contained in a "TITLE END" pack which is provided in a predetermined location of the accessory data (AAUX or VAUX).  
15 In addition, the signal processing microcomputer generates a title time code (TTC) which is stored in the subcode data. It will be recalled that the subcode data is employed in a high-speed search of the video program; and the title time code (TTC) is used in displaying a sub-title on a video monitor during the high-speed search.  
20

The mode processing microcomputer 34 may be operated synchronously with the TV image frequency of 60 Hz or 50 Hz. The signal processing microcomputer 20, on the other hand, operates at much higher rates and in synchronism with the rotary drum of

the VTR which rotates at a frequency of 9,000 rpm (translating to a frequency of 159 Hz).

The VAUX, AAUX and the subcode data generated by the signal processing microcomputer 20 are supplied respectively to VAUX circuit 17, AAUX circuit 19 and subcode circuit 18. The VAUX data recalled from VAUX circuit 17 is inserted into the frame generated by framing circuit 15 by adder 16, thereby forming video data (VDATA). The AAUX data recalled from the AAUX circuit 19 is inserted into the frame generated by framing circuit 23 by adding circuit 24, thereby forming the audio data (ADATA). The subcode data stored in subcode circuit 18 is generated as SID data and the AP3 of the ID section and the data pack SDATA.

The foregoing describes generating the accessory data. The recording of that data will now be described. A switch 26 selectively switches between inputs of AV ID pre-sync/post-sync data produced by a suitable generator 25, the ADATA formed by adding circuit 24, the VDATA formed by adding circuit 16, the SID and the SDATA from subcode circuit 18, and the digital bus data. Switch 26 is timed to switch between these inputs in order to form audio, video and subcode areas, such as the audio area shown in Fig. 1. For example, the pre-sync/post-sync data generated by the AV ID pre-sync/post-sync circuit 25 is selected initially by switch 26. Then, switch 26 forms sync blocks for each area by switching between the audio data (ADATA), the video data (VDATA),

the SID and the subcode data (SDATA) inputs. In addition, switch 26 selectively switches to the digital bus input for receiving information from a digital bus. The details of the processing of the digital bus will be described in more detail below with  
5 reference to Fig. 33.

The data selected by switch 26 is sent to an error correcting code generation circuit 27 for generating the parity codes (C1, C2) shown in Fig. 12A. The selected data and parities generated by the error correcting code generation circuit are  
10 sampled by a random sampling circuit 29 in order not to shift the data to be recorded. A 24/25 conversion circuit 30 performs 24-bit to 25-bit conversion to remove d.c. components from the data; and an adding circuit 31 adds sync pattern data (Fig. 11A) to the data converted by the 24/25 conversion circuit 30. Although not  
15 shown, the 25-bit data may be further subjected to (1/1-D2) coding by a partial response class 4 (PR4) technique.

A switch 32 selectively switches between the data generated by adding circuit 31, an amble pattern pre-formed by the VTR, and insert and track information (ITI) circuit 33 to  
20 form the data on a track of the record medium according to the tape format of Fig. 1. Initially, switch 32 switches to the ITI input terminal at the beginning of each track to form therein the ITI data. Switch 32, next, selects the amble pattern input terminal to input the amble pattern. Switch 32, then, selects  
25 the audio, video or subcode data; and then another amble pattern

is formed on the track by selectively switching switch 32 to its  
amble pattern input terminal.

The ITI data is stored in ITI data circuit 33 by mode  
processing microcomputer 34. The mode processing microcomputer  
5 generates the ITI data from the application ID (APT), the SP/LP  
setting set by a user and the pilot frame data (PF). In  
addition, the application ID can be determined from the  
application ID (APM) from the MIC mounted within a tape cassette  
40. The MIC data is retrieved by an MIC microcomputer 38 through  
10 a MIC contact 39 from the MIC of the tape cassette 40.

After the information is arranged into the tape format  
of Fig. 1 by switch 32, the information is ready to be recorded  
on the record medium. Dual recording heads 37a, 37b, (Fig. 20)  
of the VTR record the information alternately in different tracks  
15 of the record medium. A switch 35 alternately switches the  
information to the dual recording heads according to an  
alternating sequence in order to alternately record the  
information of Fig. 1 into successive tracks. A first amplifier  
36a amplifies the information switched to the first head 37a and  
20 a second amplifier 36b amplifies the information switched to the  
second head 37b.

Recording Circuit Example Recording Accessory Data

As an example of the operation of the recording circuit  
described with reference to Fig. 20, the recording of the video  
accessory data (VAUX) will be explained. While this example  
25

pertains to the VAUX data, it will be appreciated that the recording of the AAUX data follows the same operations since these accessory data items have the same data structures.

5 The mode processing microcomputer 34 shown in more detail in Fig. 21 generates the VAUX pack data. A pack data generation circuit 100 generates the pack data shown in Fig. 15 as 8 parallel bits. These 8 parallel bits are converted into a stream of serial bits by a parallel/serial converting circuit 108 for transmission from the mode processing microcomputer to signal  
10 processing microcomputer 20 via mechanical control microcomputer 28 according to an intra-microcomputer communication protocol.

After transmission of the serial bits, serial/parallel converter 109 of the signal processing microcomputer converts the transmitted serial bits back into 8 parallel bits of pack data.  
15 These 8 bits of parallel pack data are sent to both a pack header sensing circuit 110 and a switch 112. The pack header sensing circuit senses the pack header, for example, from the byte PC0. The pack header sensing circuit retrieves the pack header located at the beginning of each pack of five bytes and determines  
20 therefrom whether the pack data needs an absolute track number. When an absolute track number is needed, the pack header sensing circuit causes switch 112 to switch to an absolute track number generation circuit 111 and receive therefrom the needed absolute track number. This absolute track number determines the fixed  
25 location on the record medium for the packs and the track number

data is provided in PC1 or PC2 or PC3. Normally, switch 112 selects the pack data and pack header from serial parallel converter 109 for storage in buffer 113, and when necessary, the absolute track number is supplied by the switch to the buffer.

5 Preferably, signal processing microcomputer 20 is run by software in order to avoid costly use of ASICs (Application Specific Integrated Circuit) hardware. For example, the function of serial/parallel converting circuit 109 is performed by a serial I/O port of the signal processing microcomputer. Sensing  
10 the pack header can be achieved by a software program run by the signal processing microcomputer instead of using a pack header sensing circuit embodied in hardware. Similarly, absolute track number generation circuit 111 and switch 112 are replaced by software programs run by the signal processing microcomputer.  
15 Buffer 113 may be constructed as a RAM of the signal processing microcomputer. In practice, the signal processing microcomputer is sufficiently fast to process the data packs using the above-described software, and costly ASIC hardware may be avoided.

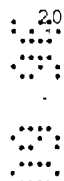
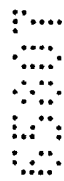

20 The pack data stored in buffer 113 is, then, sent to VAUX circuit 17 at the command of a write timing controller 115. The VAUX circuit distinguishes between the main area (Fig. 13) pack data (which stores mainly essential items such as the sampling frequency and number of quantizing bits) and the optional area data. The write timing controller controls switch  
25 114 to switch the first half of 6 packs, where the main area

information is carried, to a FIFO buffer 116. After the main area pack data is coupled to FIFO 116, the write timing controller controls switch 114 to switch the optional area pack data to a FIFO buffer 117 for the remaining 390 packs.

5 Preferably, the FIFO 116 for the main area pack data has a capacity of 30 bytes, while the FIFO 117 for the optional area pack data has a capacity of 1950 bytes for a 525 lines/60 Hz system and a volume of 2340 bytes for a 625 lines/50 Hz system.

10 The data packs stored in FIFOs 116, 117 are recorded on the record medium as the VAUX data of the video signal. The recording of the VAUX data is controlled by a read timing controller 119 which controls a switch 118 to selectively switch between the FIFO 116 for the main area when the main area pack data is recalled therefrom and the FIFO 117 for the optional area  
15 when the remaining optional area data packs of the VAUX data is recalled therefrom. The read timing controller performs this switching on the basis of a track number of a frame and a sync number of a track within that frame. In this manner, the main area and the optional area pack data are read from FIFOs 116, 117  
20 and sent to adding circuit 16 to be inserted into the frame of video data generated by framing circuit 15.

25 A specialized data pack, such as a TR pack includes video picture information relating to, for example, PAL and EDTV-2 television standards. A TR pack may be designated by a value of 66h in the pack header PC0, for example. The byte PC1 is used

to indicate the type of data that follows in bytes PC2 to PC4.  
Generally, a single TR pack is included with each main area (Fig.  
13). However, if additional TR packs are included in, for  
example, the sixth data pack of the main area, this additional  
5 data also is written to the FIFO 116 for the main area.  
Similarly, a closed caption pack that contains closed captioned  
data for the hearing impaired in the main area also is written in  
the FIFO 116 for the main area. Preferably, the additional pack  
data (TR pack or closed caption pack) is written to the FIFO 116  
10 for the main area for each track pair.

The VAUX data is inserted by adding circuit 16 into,  
for example, the video sync blocks 19, 20 and 156 shown in Fig.  
22A in the frame generated by framing circuit 15. It will be  
noted that the main area is located at the second half of video  
15 sync block 156 on + azimuth track and in the first half of the  
video sync block 19 for - azimuth track. Fig. 22B shows ten  
tracks (TRACK 0 ... TRACK 9) which are used to record one video  
frame, wherein it will be noted that the main area located at the  
first half of video sync block 19 and at the second half of block  
20 156 form adjacent pairs when the tracks are alternately  
sequenced. The present invention provides an nMAIN signal that  
is timed to generate a pulse for each adjacent pair of main area  
data packs. The nMAIN signal is generated by read timing  
controller 119 (Fig. 21) to control switch 118 to output the main  
area pack data from the FIFO 116 during the second half of video  
25

sync block 156 and the first half of video sync block 19 during the low level state "L" of the nMAIN signal.

Generally, a single TR pack or a single closed caption pack is recorded as the sixth pack of the main area data packs  
5 and the VTR records the data stored in the FIFO 116 for the main area ten times for a 525 line/60 Hz (12 times for a 625 line/50 Hz) video system as shown in Fig. 13. On the other hand, when a plurality of TR packs or closed caption packs are recorded, the data stored in the FIFO 116 for the main area is read twice  
10 during the low level state "L" of the signal (nMAIN) because such data are written in the FIFO 116 for each track pair; that is, the same data are written into each track. When the signal (MAIN) is set to the high level state "H", the read side timing controller causes FIFO 117 for the optional area to output the  
15 optional pack data.

VAUX Pack Data Generation Circuit

The VAUX pack data generation circuit 100 (Fig. 21) of mode processing microcomputer 34 (Fig. 20) will be described in more detail with reference to Fig. 23. The VAUX pack data  
20 generation circuit includes a data collecting and generating circuit 101 for the main area packs and a data collecting and generating circuit 103 for the optional area packs.

The data collecting and generating circuit 101 for the main area packs receives data such as CGMS, CP, DISP and CLOSED  
25 CAPTION data from a digital bus or a tuner and generates the data

groups shown in Fig. 24 therefrom. These data groups are preferably inserted into reserved fields of the main data pack. A pack header (60h ... 65h) is inserted into byte 0, for example, of a main area data pack by control of a switch 102. The pack  
5 header and the data group generated by the data collecting and generating circuit for the main area data packs are coupled to a parallel/serial converter 108 through a switch 106.

The data collecting and generating circuit 103 for the optional area data packs receives, for example, TELTEXT data and  
10 PROGRAM TITLE data and generates therefrom the data to be inserted into the optional area packs. The optional area packs have a pack header set by a pack header setting circuit 104 which is selectively inserted into byte 0, for example, of the optional data pack by operation of switch 105. The resulting optional  
15 pack data is coupled to parallel/serial converter 108 through switch 106.

A timing adjusting circuit 107 controls the timing of switches 102, 105 and 106 to couple the main and optional area pack data to the parallel-to-serial converter 108. By operation  
20 of switch 106, the main area pack data and its pack header inserted therein is output to signal processing microcomputer 20 (Fig. 20), as are the operational pack data with its pack header inserted therein. The signal processing microcomputer, then, stores the VAUX pack data in VAUX circuit 17 for later insertion  
25 into the frame by adding circuit 16.

Preferably, VAUX pack data generator 100 is a processor which employs software to generate the main area and optional area pack data. In this preferred embodiment, the parallel/serial converter is one of the serial I/O ports of the mode processing microcomputer 34 (Fig. 20). It is also preferred that software programs perform the functions of: data collecting and generating circuit 101 for the main area; switch 102 for determining a pack header for the main area pack data; data collecting and generating circuit 103 for the optional area; pack header setting circuit 104 for setting a pack header of the optional area pack data; switch 105 which forms the optional area pack data from the optional area pack header and the optional area pack data; switch 106 which selects the main area and optional area pack data; and timing adjusting circuit 107 which controls switch 106. With this preferred embodiment, the VAUX pack data generator 100 is embodied as a software-run processor and, as a result, costly ASIC hardware is avoided.

The AAUX pack data generator included within mode processing microcomputer 34 is shown in Fig. 25 and is similar to the VAUX pack data generator of Fig. 23. The similarities between these circuits will not be discussed here, but are apparent from the description of the VAUX pack data generator of Fig. 23. The AAUX pack data generator of Fig. 25 generates AAUX pack data and the data input thereto relates to audio data. Thus, one difference from the VAUX pack generator is that the

types of data processed by AAUX pack data generator are audio  
types. For example, the program title for the optional area is  
the title of a music program, for example, a digital audio PCM  
program. Another difference from the VAUX pack data generator of  
5 Fig. 23 is that the AAUX pack data generator of Fig. 25 further  
includes a decoder 129 for extracting closed caption data  
normally carried in the vertical blanking period of a received  
video signal. Once the closed caption information is extracted  
from the vertical blanking period, it is treated in the same  
10 manner as the data of the VAUX pack data generator of Fig. 23.

A data collecting circuit 121 for the main area data  
packs receives several kinds of data such as CGMS, AUDIO MODE,  
SMP, QU and CP from a digital bus and from a tuner and generates  
various kinds of data packs as indicated in Fig. 26. The  
15 generated data packs are arranged in a main pack and pack header  
is added thereto by a switch 122. The resulting data pack is  
applied to a parallel/serial converter 128 through a switch 126.

A data collecting circuit 123 for the optional area  
data packs receives data such as a program title from the tuner.  
A pack header is set by a pack header setting circuit 124 and is  
20 added to the pack data through a switch 125. Then, the resulting  
pack is applied to converter 128 through switch 126. The timing  
of switches 122, 125 and 126 is controlled by a timing adjusting  
circuit 127.

Similar to the VAUX pack generator, the converter 128 preferably is a serial I/O port of the microcomputer; the data collecting circuit 121, the switch 122, the data collecting circuit 123, the pack header setting circuit 124, the switches 125 and 126, and the timing adjusting circuit 127 are implemented by software programs run in the microcomputer 34.

#### Data Pack Recording

The recording of the accessory data has been discussed above and a more detailed description of the recording of the pack data will now be described in conjunction with Fig. 20. The AV ID pre-sync/post-sync circuit 25 generates synchronizing signals for synchronizing the sync blocks of the data packs. These synchronizing signals include application IDs (AP1, AP2), a pre-sync and a post-sync of the audio/video (AV) signal.

Switch 26 selectively switches between these synchronizing signals, the audio data (ADATA), the video data (VDATA), the SID, and the subcode data (SDATA) to generate the areas of sync blocks shown in Fig. 10. These signals are coupled to error correcting code generation circuit 27 which adds the parities C1, C2 to the sync blocks (for example, as shown in Fig. 12A).

A channel encoder receives the ECC-encoded signals from error correcting code generation circuit 27 and performs a random-sampling operation thereon using random sampling circuit 29 which does not shift the recording data. Then, 24/25

converter 30 performs 24 to 25 conversion to convert the 24 bits  
of the sampled data into 25 bits. Advantageously, the 24 to 25  
conversion removes a DC component from the recorded data. The 24  
to 25 conversion may include Partial Response Class 4 (PRC4)  
5 coding process ( $1/1 - D^2$ ) which prepares the data for magnetic  
recording.

The channel encoder, then, arranges the converted data  
into the tape format of Fig. 1 for recording on the record  
medium. Since each track begins with Insert and Track  
10 Information (ITI), switch 32 selects the ITI circuit 33 to  
receive the ITI area data therefrom. Switch 32, then, selects  
the amble pattern followed by the data converted by the 24/25  
conversion circuit 30. The data arranged into the track format  
shown in Fig. 1 is further arranged into data areas, such as the  
15 audio area shown in Fig. 10, by combining the audio data from  
converter 30 with the A/V sync pattern and the subcode sync  
pattern in adder 31. Switch 35, then, switches again to the  
amble pattern, thereby bounding each data area by an amble  
pattern in accordance with the tape format shown in Fig. 1.

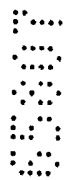

The ITI data format including the pre-amble, the post-  
amble and the Start Sync Block Area (SSA) may be internally  
generated by ITI circuit 33. The Track Information Area (TIA)  
which contains the application ID (APT) indicating an arrangement  
of the data packs, the standard-play/long-play setting (SP/LP),  
and the pilot frame (PF) are dependent upon external information

and, therefore, are provided externally to the ITI circuit 33 from, for example, mode processing microcomputer 34.

5 The mode processing microcomputer 34 interfaces with the user and generates mode information from user-selected settings. Switch 41 represents an array of switches selectable by the user for setting the modes of the mode processing microcomputer. The array of switches 41 may include, for example, an SP/LP recording mode setting switch for setting the mode processing microcomputer to a standard-play or a long-play  
10 mode. The mode processing microcomputer senses the SP/LP recording mode set by the array of switches 41 and generates the SP/LP data therefrom.

15 The mode processing microcomputer 34 further controls the mechanical operations of the VTR from the switch array 41 settings. For example, if the user sets the SP/LP recording mode from the standard-play (SP) to the long-play (LP), the mode processing microcomputer causes mechanical control microcomputer 28 to reduce the speed of the tape medium to correspond to the slower, long-play speed.

20 The mode processing microcomputer also generates the application ID (APT) which is sent to the ITI circuit 33 for insertion into the TIA area of each track. The application ID (APT) may be generated by the settings of the array of switches 41 or may be determined by the application ID (APM) of the Memory IC (MIC), a memory housed in the tape cassette 40. An MIC  
25





35 switches to the data collecting and generating circuit 133 for receiving therefrom the optional area data.

The main area pack data including the pack header 1Fh and the optional area pack data including the pack header from  
5 pack header setting circuit 134 is sent to an IIC bus interface circuit 138 via switch 136. A timing adjusting circuit 137 controls switches 132, 135 and 136 to alternately select between the main and optional area pack data, thereby synthesizing the main and optional area packs. The IIC bus interface circuit  
10 interfaces the main and optional area pack data synthesized by switch 136 according to a communication protocol of the MIC. In this manner, the application ID from mode processing microcomputer 34 is formed into pack data and sent to the MIC for storage.

15 Preferably, the MIC microcomputer 38 is a processor which performs the application ID processing using software programs. The data collecting circuit 131 for the main area and the data collecting circuit 133 for the optional area preferably supply data to a RAM internal to the MIC microcomputer. With  
20 this preferred embodiment, costly ASIC hardware can be avoided.

25 Additionally, the MIC may include Table Of Contents (TOC). The TOC is useful for organizing the recorded data, such as the name of different video programs on the tape. The recording locations are provided by the VTR, but may also be generated by the MIC microcomputer and stored in the TOC if the

recording locations are not available from the VTR. Similarly, other information generally provided by the VTR can be generated by the MIC microcomputer and stored in the TOC until the VTR provides this information.

5           The mode processing microcomputer 34 generates the application ID (APT) and forwards this information to the ITI circuit 33. Switch 32 selects the ITI data from the ITI circuit at the beginning of each track, followed by amble patterns and, then, the audio, video and subcode data; thereby forming tracks  
10 of information on the tape with the format of Fig. 1 for recording on the record medium. Switch 35 alternately switches between the amplifiers 36a and 36b of dual heads 37a and 37b, respectively. The dual heads 37a and 37b alternatively record the track information formed by switch 32 on successive tracks of  
15 the record medium (not shown) which correspond to the plus and minus azimuth tracks shown in Fig. 22A.

          In this manner, the recording circuit of Fig. 20 records the audio, video and subcode data on tracks of the record medium. In practice, the operations performed by the recording  
20 circuit are executed chiefly by the mode processing microcomputer 34 in association with the mechanism control microcomputer 28, the signal processing microcomputer and the ICs in charge of the operating components.

TV Signal Determining Unit

The TV signal determining unit 60 of Fig. 20 operates to determine whether a composite video signal and is a TV broadcast signal and is shown in Fig. 28. The composite video signal is switched by switch 3a (Fig. 20) to the TV signal determining circuit. For purposes of example, the composite video signal is treated as an analog video signal having lines formed within two fields (odd and even); such a signal is typical of a PAL or a EDTV-2 video signal. A sync separation circuit 61 senses the vertical and horizontal synchronizing signals from the composite video signal. A line counter 62 counts the current line number of the composite video signal by incrementing a counter when the horizontal synchronous signals are sensed by the sync separation circuit. The line counter generates a **START READ** command when it senses line 17 of the composite video signal because this line includes the VITS signal (Figs. 17A, 17B) that indicates the presence of a TV broadcast signal. It will be recalled that the TBC of the United States transmission system shifts line 17 to either line 16 or line 18. Therefore, it is desirable in the present invention to search for the VITS signal in these lines.

The composite video signal is sent to a data slicer 63 of the TV signal determining circuit to convert the composite video signal from an analog video signal to a 1-bit digital signal. For example, if the analog video signal exceeds a

threshold slice level, the data slicer generates a high level value of "1". On the other hand, if the analog video signal does not exceed the threshold slice level, the data slicer generates a low level value of "0". Typically, the VITS signal indicative of the TV broadcast signal in the second field of Fig. 17B has a mean value of approximately 60%. Accordingly, it is preferred to set the slice level to approximately 70% to detect with assurance the VITS signal in the second field.

Since the composite video signal is continuous, data slicer 63 generates a stream of 1-bit digital values. These 1-bit digital values are sent to a data-read circuit 66 which reads this stream of 1-bit digital values when line 16 is sensed, at a sampling rate determined by sampling clock generator 64. When line counter 62 senses lines 16 to 18 of the composite video signal, the line counter issues a **START READ** command to the data read circuit to cause the data read circuit to read the stream of 1-bit digital values generated by data slicer 63 for these lines. In this manner, the data read circuit reads the stream of 1-bit digital values generated by the data slicer for lines 16, 17 and 18 at the sampling rate provided by the sample clock generator and the data read circuit sends the read bits to a register 67.

A slicer microcomputer 60B senses that a stream of bits is registered by register 67 and concludes therefrom that the data slicer has sensed the VITS signal of the TV broadcast signal. In addition, the slicer microcomputer sets the slice

level of the data slicer to a level which will accurately sense the VITS signal. Preferably, the slice level is set to 70% to detect, for example, the VITS signal with a mean value of 60% in Fig. 17B. The slicer microcomputer further selects the line numbers sensed by line counter 62. It is preferred that the slicer microcomputer selects line numbers 16 to 18 since the VITS signal may occur in any of these lines according to different broadcasting systems. The slicer microcomputer additionally selects the sampling frequency of the sampling clock generator to sample the data read by data read circuit 66 at a sampling rate sufficient for detecting the VITS. In addition, the slicer microcomputer resets the register 67 by issuing a **CLEAR** command thereto, for example, as controlled by mode processing microcomputer 34.

#### Sample Clock Generator

The sample clock generator 64 generates the sampling clock at the sampling frequency selected by the slicer microcomputer. A phase locked loop (PLL) circuit is provided within the sample clock generator for matching the phase of the generated sampling clock to the phase of the composite video signal received by the TV signal determining circuit 60. A comparison signal derived from the horizontal and/or vertical sync signal is generated by sync separation circuit 61 to which the PLL matches the phase of the sampling clock. For the purpose of phase matching, the sampling clock generator generates a sync

signal having regular intervals. Such a sync signal may be generated by thinning serrated pulses and equivalent pulses in the vertical blanking period from the horizontal sync signal obtained by the sync separation circuit 61. The PLL circuit  
5 compares the phase of the comparison signal to an oscillation signal generated by, for example, a crystal oscillator 66 or, alternatively, by an inexpensive LC circuit. The comparison is made by frequency-dividing the oscillation signal and comparing the phases of each of the frequency-decoded pulses to the  
10 comparison signal, whereby the PLL sketches the phase of the sampling clock signal generated by sample clock generator 64 to the phase of the received horizontal (or vertical) sync signal.

The sample clock generator 64 may be made more stable by using both the vertical sync signal and the horizontal sync  
15 signal for comparison. With this arrangement, the PLL locks in both a one-line horizontal period and, at the same time, locks the one-frame (or one-field) vertical period. With this preferred embodiment, clock variations caused by a large swell in the period (i.e., a low frequency) are prevented.

20 Preferably, data read circuit 66 is timed to read on the leading edge of the horizontal sync signal provided by sample clock generator circuit 64. In this manner, the 1-bit stream of the VITS signal generated by data slicer 63 is read by data read circuit 66 at the sampling frequency of sample clock generator  
25 circuit 64 and stored in register 67.

It will be appreciated that the sampling frequency selected by slicer microcomputer 60B should be twice the frequency of the signal sampled in order to reconstruct the sampled signal without aliasing in satisfaction of Nyquist's theorem. If the preferred sampling clock frequency is 128/H, the value "0" is produced at samples 1 to 24, the value "1" is produced at samples 25 to 32, and the value "0" is produced at samples 33 to 36.

Frequency-Dividing Method

The mode processing microcomputer 34 is occupied with operations concerning the recording circuit of Fig. 20 and delegates control over the TV signal detecting circuit of Fig. 28 to slicer microcomputer 60B. The slicer microcomputer sets the sampling frequency by setting a dividing value of the feedback loop in the PLL of sample clock generator 64. Since the slicer microcomputer is a computer processor, it is preferred that the method of frequency-dividing is embodied in software to avoid using costly ASIC hardware.

An example of a preferred frequency-dividing method is described with reference to Fig. 28. Let it be assumed that the sampling clock to be frequency-divided is a digital value with: bits 1 to 24 set = "0"; bits 25 to 32 set = "1"; bits 33 to 36 set = "0". Hence, the sampling clock may appear as the string "1100011000". It will be appreciated that the number of "1"s in the repetitive string is not equal to the number of "0"s because

the slice level of preferably 70% is above the mean average (60% as shown in Fig. 17B).

It is preferred that the sampling frequency is selected as high as possible in order to obtain many samples thereby  
5 increasing the accuracy of identifying the VITS signal. However, increasing the sampling frequency is not practical because the increase in samples is impractically large for register 67 to handle. Accordingly, the number of samples is maintained at manageable levels by detecting a portion of the VITS signal. For  
10 example, the VITS signal comprises sinusoidal waves at 0.5MHz, 1MHz, 2MHz, 3MHz, 3.58MHz and 4.2MHz; and the present invention detects the sinusoidal waves up to 1MHz, thereby ignoring the samples in other frequencies and reducing the number of samples.

Detection accuracy is increased by detecting the VITS  
15 signal in, for example, 10 consecutive frames. The detection result is supplied to data collecting and generating circuit 101 (Fig. 23) for the main area packs and switch 102 selects this detection result during the main area data packs. That is, the detection result indicating the presence of a TV broadcast signal is stored with the TV broadcast signal on the record medium in  
20 the main area data packs. This detection result is later retrieved from the main area packs upon reproduction by a reproducing circuit. The retrieved detection result is used to prevent copying of the TV broadcast signal when it is reproduced by the reproducing circuit of the VTR.

Reproducing Circuit

The reproducing circuit for reproducing video signals recorded in the tape format of Fig. 1 is shown in Figs. 29 and 30. Dual reproducing heads 201a and 201b reproduce the video signals from alternating tracks on the record medium as shown in, for example, Fig. 22A. The video signals reproduced from the record medium by the reproducing heads are amplified by amplifiers 202a and 202b, respectively. The reproduced and amplified video signals are selected alternatively by a switch 203 to form a serial video signal and sent to equalizer circuit 204 which performs a reverse partial response class 4 emphasis to improve the electromagnetic converting characteristic of the reproduced signals.

A clock extracting circuit 205 extracts a clock component from the signal output of equalizer circuit 204 and generates therefrom a clock signal (CK). An analog-to-digital conversion circuit 206 converts the signal output from the equalizer circuit at a timing provided by the clock signal (CK) into digital data which is written into a FIFO buffer 207 at timing provided by the clock signal (CK).

Although the clock signal (CK) may be tainted by a jitter component due to mechanical vibrations in the rotation of the heads, this is not a problem when the video signals are sampled by this clock signal because the video signals also contain the jitter component. Analog-to-digital conversion

circuit 206 converts the video signals into digital data and the jitter component is effectively filtered out of the digital video signal. Thus, when FIFO buffer 207 stores the digital video signal at a timing provided by the clock signal (CK) which has  
5 the jitter component, the clock signal (CK) is considered unstable and the digital video signal stored in the FIFO 207 may be sampled incorrectly.

Time base correction is provided by using a stabilized clock signal (SCK) to read the digital video signal from the FIFO  
10 207. The stabilized clock signal (SCK) may be provided by an oscillating circuit 239 having a crystal oscillator 238 and a frequency divider 240 as shown in Fig. 30.

Preferably, the FIFO 207 stores the digital video signal at a faster write rate than the read speed at which the  
15 stored data is read from the FIFO 207. This ensures that data is always present in the FIFO 207 such that an underflow condition does not occur.



A sync pattern sensing circuit 208 senses sync patterns in the digital video signal recalled from the FIFO 207 and  
20 operates a switch 210 on the basis of the sensed sync pattern in order to segregate the sync blocks of data read from the FIFO. Different types of sync pattern references are provided to the sync pattern sensing circuit from a switch 209 which switches between an ITI sync pattern, an A/V sync pattern and a subcode  
45 sync pattern as these signals are played back from their

respective areas on a track and read from FIFO 207. Switch 209  
is switched according to the timing provided by a timing circuit  
213 which generates a **SYNC PATTERN SELECTION** command to actuate  
switch 209 on the basis of a predetermined order of sync  
5 patterns.

The sync pattern sensing circuit 208 preferably has a  
fly-wheel structure that detects a particular type of sync  
pattern after a particular sync block length is read. If the  
proper sync pattern is sensed correctly, for example, three times  
10 or more, the sync pattern sensing circuit determines the sync  
pattern to be true; and this prevents erroneous detection of the  
particular type of sync pattern. The fly-wheel structure for  
detecting the particular sync pattern is best implemented if the  
FIFO 207 has, for example, three stages when sensing the  
15 particular sync pattern three times.

Sync blocks are shifted along the stages of the FIFO  
207 by a predetermined amount following the sensing of the shift  
pattern; and this predetermined amount is produced by sync  
pattern sensing circuit 208 to close switch 210 on a track and  
read from FIFO 207, whereupon the FIFO 207 is connected to a sync  
20 block setting circuit 211. The sync block setting circuit  
latches the information bit read from the FIFO, including the  
sync number of the sync block being read out. The sync number is  
extracted by extracting circuit 212 and sent to timing circuit  
213 which determines the location of the corresponding sync block  
25

on the track currently scanned by the reproducing heads. From  
the determined location, timing circuit 213 controls switch 209  
to switch among the types of sync patterns; and controls switch  
214 to couple the data sync blocks to a channel decoder I and the  
5 ITI sync blocks to channel decoder II. That is, when the  
reproducing heads are scanning the ITI sector, switch 214 is  
switched to the channel decoder II and, when the reproducing  
heads are scanning the audio, video or subcode sectors, switch  
214 is switched to channel decoder I.

10 When switch 214 is switched to channel decoder II, the  
ITI sync blocks are sent to a subtracter 215 to remove the ITI  
sync pattern from the ITI sync blocks; and the remaining ITI data  
is decoded by an ITI decoder 216 to recover the application ID  
(APT), the SP/LP data and the pilot frame (PF), for example. The  
15 decoded ITI data is coupled to mode processing microcomputer 217  
for determining the modes of the VTR. For example, a long-play  
mode indicated by the SP/LP data causes the mode processing  
microcomputer to, in turn, cause mechanical control microcomputer  
228 to mechanically control the speed of the tape to effect long  
play reproduction.

20 The SP/LP data is also sent to timing circuit 213 for  
controlling the timing of the VTR operations in accordance with  
the standard or long play. The application ID (APT) is sent from  
mode processing microcomputer 217 to a signal processing  
25 microcomputer 251 to link related audio, video and subcode data.

In addition, the application ID (APT) is sent by the mode processing microcomputer to a MIC microcomputer 219 for use in managing the MIC application ID (APM). Information from the MIC in cassette 221 is supplied to MCI microcomputer 219 via contact 5 220; and microcomputers 219 and 217 process this MIC data. MIC microcomputer 219 may, as an alternative, be omitted, leaving mode processing microcomputer 217 to control the overall system operation in association with mechanical control microcomputer 228 and signed processing microcomputer 251.

10 Similar to the recording circuit of Fig. 20, mode processing microcomputer 217 of the reproducing circuit of Fig. 29 includes a user-selectable switch array 218 to switch between different modes of the VTR. For example, the user may select a special playback mode, such as a fast/forward or fast/reverse playback mode. As in the recording circuit, the mode processing 15 microcomputer here is generally responsible for controlling the overall VTR operations in association with mechanical control microcomputer 228 and signal processing microcomputer 251.

When switch 214 is switched by timing circuit 213 to channel decoder I, the audio, video and subcode sync blocks are sent to the channel decoder I and the sync patterns therein are subtracted from the corresponding sync blocks by subtractor 222. The remaining audio, video and subcode data after subtractor 222, then, undergoes a reverse 24/25 conversion in the reverse 24/25 conversion circuit 223. Next, a reverse random numbering circuit 25

224 reverses the random numbering of the audio, video and subcode samples, returning these samples to their original data sequence.

The re-formed data sequence is error corrected by error correction circuit 225 using the parity codes (C1, C2) shown in  
5 Fig. 12A. If the error correction circuit is not able to completely correct the audio, video and subcode data, the error correction circuit produces an ERROR flag that is output with the audio, video and subcode data (ADATA, VDATA, SID, SDATA). An error interpolation circuit 301 also receives the ERROR flag and  
10 performs error interpolation on the audio, video and subcode data when this ERROR flag indicates that the error correction circuit did not completely error correct the data. The error interpolated data is packeted by a packeting circuit 302 and transmitted thereafter to a digital bus input 305 by a  
15 transmission error correcting code generation circuit 303 for adding a parity code to the packeted data and a driver 304 for buffering the packeted data.

Switch 226 is switched by timing circuit 213 to an AV ID pre-sync/post-sync circuit 227 which extracts the ID data and the pre-sync and post-sync blocks from the audio and video areas.  
20 The data in the pre-sync and post-sync blocks include the sync number, the track number of the corresponding track read from the record medium and the SP/LP data. The timing circuit controls switch 226 based on this information to locate the audio, video

and subcode data and to switch this data to the appropriate outputs (ADATA, VDATA, SID, SDATA).

The AV ID pre-sync/post-sync circuit 227 also extracts the application ID's (AP1, AP2) which determine the arrangement  
5 of the areas in each track. For example, as shown in Figs. 5A and 5B the areas (AREA1, AREA2, AREA 3) are reserved for an audio area, a video area and a subcode area when the application IDs (AP1, AP2, AP3 = 000). Preferably, this arrangement is the  
10 default condition and mode processing microcomputer 217 operates normally when these application IDs are set = "000". When these application ID's are set to another value, the mode processing microcomputer performs a warning operation, such as an alarm.

It will be recalled that the SP/LP data is stored in both the ITI data and the pre-sync block of each area. Both  
15 versions of the SP/LP data are retrieved from the ITI generated by the channel decoder II and from the pre-sync SP/LP data by the AV ID pre-sync/post-sync circuit 227, respectively. The SP/LP data is written three times in the TIA area of the ITI data and once in each of the two pre-sync blocks for both the audio and  
20 video areas (4 times). The correct SP/LP data for the TIA area in the ITT is determined by majority decision of the values of the thrice written SP/LP data. The SP/LP data for the pre-sync blocks is also determined by majority decision. If these two majority decisions do not agree, priority is placed on the SP/LP  
25 data in the ITI area.

The audio data (ADATA), the video data (VDATA), the subcode data (SID, SDATA) and the error flag (ERROR) provided by switch 226 in Fig. 29 are sent to the next stage of the reproducing circuit shown in Fig. 30. Switch 229 separates VDATA  
5 into video data and VAUX data. The video data is sent to a deframing circuit 230 to deframe the video data framed by framing circuit 15 (Fig. 20) in the recording circuit. The deframing circuit also receives the ERROR flag indicating that the error correction circuit 225 (Fig. 29) did not completely correct the  
10 errors in the video data and, in response thereto, executes propagating error processing. The propagating error processing corrects the affect of the error on other picture data. When the error is not significant, it is preferred that the deframing circuit does not perform error correction; instead, the video  
15 data is processed in an effort to clear the ERROR flag.

A data reverse compressing and coding section, then, decompresses and decodes the deframed video data. It will be recalled that the data compressing and coding section 14 of the recording circuit (Fig. 20) compressed the video data using a discrete cosine transform (DCT) or a variable length code (VLC) and quantized this coded video data. Accordingly, reverse  
20 quantizing circuit 231 de-quantizes the received de-framed data and reverse compression circuit 232 decompresses the de-quantized data using an inverse discrete cosine transform (IDCT) or an  
25 inverse variable length code (IVLC).

The resulting video data is arranged in, for example,  
8 x 8 DCT blocks which were shuffled in the recording circuit to  
ensure that the video data was not lost due to head clogging or  
horizontal alignment error during recording. A deshuffling  
5 circuit 233 deshuffles the shuffled DCT blocks and a deblocking  
circuit 234 deblocks the DCT blocks.

The deshuffled and deblocked video data, which now are  
present as luminance (Y) and chrominance (R-Y, B-Y) components,  
are sent to digital-to-analog converters 235a, 235b and 235c,  
10 respectively, to convert the digital color components into  
corresponding analog color components of the video signal. These  
analog color components are synthesized by a Y/C synthesizing  
circuit 236 into an analog composite video signal to which is  
added vertical and horizontal synchronizing signals by an adder  
15 237. The synchronizing signals are generated by a sync signal  
generating circuit 241 on the basis of an oscillation clock  
generated by an oscillating circuit 239 with the use of, for  
example, a crystal oscillator 238. The resultant video signal is  
sent to the output terminal 242 as a composite video signal.

20  
25

The oscillating clock provides the sampling frequencies  
for the digital-to-analog converters 235a, 235b and 235c which  
are the same as the sampling frequencies used for A/D conversion.  
The frequency of the oscillation clock is 13.5 Mhz and is used by  
the digital-to-analog conversion circuit 235a for the luminance  
(Y) component. The digital-to-analog converters 235b and 235c

for the color difference signals (R-Y, B-Y) employ a 6.75 Mhz or a 3.375 Mhz clock by dividing the 13.5 Mhz oscillating clock by a frequency divider 240.

5 The recovered picture may be modified on the basis of the VERROR flag derived from the ERROR flag. Then, for example, the picture data of a previous frame is stored in memory. The previous frame is used to replace the present erroneous picture block.

10 The audio data (ADATA), similarly, is switched between an AAUX circuit 250 and a deframing circuit 244 by a switch 243. The deframing circuit 244 deframes the audio data framed in the recording circuit by framing circuit 23. The deframing circuit 244 also performs the propagating error process if it determines from the ERROR flag that error correction circuit 225 (Fig. 29)  
15 did not completely error correct the audio data. At this time, the audio ERROR flag is represented by an AERROR flag indicating error propagating correction data to correct the effect of the error on other audio data. For example, in 16-bit audio sampling, with each audio data section consisting of eight bits, one ERROR flag overlaps two audio data sections.

20 A deshuffling circuit 245 deshuffles the deframed audio data deframed by deframing circuit 244, thereby returning the audio data from its shuffled arrangement to the original sequence. The deshuffling circuit 245 also provides error  
25 correction in response to the AERROR flag. For example, the

deshuffling circuit 245 performs a pre-hold operation by replacing the immediately previous audio data with the erroneous audio data. In the situation where the period of the erroneous audio data is so long that replacing the erroneous audio data with the previous audio data is ineffective, the deshuffling circuit 245 mutes the erroneous audio data, thereby interrupting the sound itself.

A digital-to-analog conversion circuit 246 converts the audio data deshuffled by deshuffling circuit 245 from digital audio data to an analog audio output signal to be output from the analog audio output 247. The digital-to-analog conversion circuit is synchronized with the video data such that, for example, audio sounds are lip-synced to the persons in the corresponding video picture.

15 The VAUX, subcode and AAUX data is processed and sent to signal processing microcomputer 251. The VAUX data, for example, is separated from the VDATA by switch 229 and sent to VAUX circuit 248 along with the ERROR flag. The VAUX circuit pre-processes the VAUX data into VAUXDT data by, for example, selecting the VAUX data according to a majority decision of a plurality of duplicate sources of the VAUX data if the ERROR flag is present. Similarly, the subcode data (SID, SDATA) is pre-processed by a subcode circuit 249 by combining SID and SDATA into the SUBDT data and by relying on majority decision to correct the SUBDT data if the ERROR flag is set. An AAUX circuit

250 receives the AAUX data from the ADATA by operation of switch  
243 and performs pre-processing similar to that performed by VAUX  
circuit 243. The pre-processed VAUXDT data, SUBDT data and  
AAUXDT data is, then, sent to signal processing microcomputer  
5 251. If errors are left after the pre-processing, the error  
signals VAUXER, SUBER and AAUXER are generated and sent to the  
signal processing microcomputer 251 where they are employed  
therein to correct the uncorrected error in the VAUXDT, SUBDT,  
and AAUXDT data.

10           The subcode circuit 249 further extracts the  
application ID for the subcode data (AP3) and supplies this  
application ID to mode processing microcomputer 217 via signal  
processing microcomputer 251 to check the format of the  
application ID (AP3). When AP3 = "000", AREA3 is defined as the  
15 subcode area as shown in Fig. 5B. When the mode processing  
microcomputer detects that AP3 has some other value, a warning  
operation is performed by the mode processing microcomputer, such  
as an alarm.

It will be recalled that the same pack data is written  
in the main area (Fig. 13) ten times in a 525 lines/60 Hz system.  
Hence, if some of the written data packs are corrupted, the other  
data packs may be used to supplement the corrupted data. In this  
case, the ERROR flag is not employed to correct the error. The  
optional area data packs, on the other hand, are written only  
once and, error correction cannot be performed by using error-

free data packs. Instead, error correction is performed in this case using the ERROR data (VAUXER, AAUXER).

The error correction of the audio, video and subcode data is performed by signal processing microcomputer 251 using a propagation error process and a data modifying process based on an error correction result inferred from the context of each data pack. The success of the error correction is, then, supplied to mode processing microcomputer 217, which determines the next course of action for the VTR. For example, when the error correction process is successful, the mode processing microcomputer determines that the VTR operation may proceed.

#### Error Correction Example

An example of the error correction process will be described with reference to Figs. 31 and 32. This example specifically describes error correction of the video accessory data (VAUX). Error correction of the audio accessory data (AAUX) is performed using equivalent processes and circuit structures; and in the interest of brevity, is not described herein. In the following example, VAUX data is not written in memory if an error takes place; and error correction on the basis of a majority decision is not discussed.

The VAUX circuit 248 shown in detail in Fig. 31 receives the VAUX data and the ERROR data. The VAUX data is switched by switch 261 between a memory 265 for the main area data packs and a FIFO buffer 268 for the optional area data

packs. A write timing controller 262 operates switch 261 on the basis of a track number of the current frame and a sync number of the current track. For example, when the VAUX data on the + azimuth track (Fig. 22A) at sync number 156 is detected, the  
5 write timing controller switches switch 261 to couple the main area data packs of the VAUX data of sync block 156 to memory 265. Fig. 22B shows the nMAIN timing signal generated by write side timing controller 262 to change switch 261 between memory 265 for the main area data packs and FIFO 268 for the optional area data  
10 packs. For example, when the timing signal nMAIN = "L", the VAUX data of the main area data packs is present and switch 261 is switched to couple this VAUX data to memory 265 for the main area. At other times, when the timing signal nMAIN = "H", the VAUX data for the optional area data packs is present and switch  
15 261 is switched to couple this VAUX data to FIFO 268 for the optional area.

A pack header sensing circuit 263 reads a header of the pack data from the main area data packs and switches switch 264 based on this pack header. Each of the data packs which store essential information in the main area of Fig. 13 (50h ... 55h) is stored in corresponding 6 x 5 x 9 memory blocks (60h ... 65h) by operation of switch 264.

Preferably, memory 265 for the main area is pre-set to "1"s for each video frame, meaning that no data exists in this  
20 memory. If an error is detected, no action is taken. On the  
25

other hand, if no error is detected, the video accessory data (VAUX) is written to memory 265 for the main area and a value of "0" is written to the ERROR flag. It will be recalled that the same data pack is written ten times in the main area for a single  
5 video frame (12 times the PAL video system). Hence, all of the written data packs in the main area should be reproduced before determining that no error exists. Accordingly, the ERROR flag is finally determined at the end of all the data packs for the main area and stored thereafter, i.e., at the end of one video frame.

10 The optional area data packs are treated differently than the main area packs. Since the data packs for the optional area are written once, the ERROR flag can be accessed immediately; that is, without waiting for the end of the video frame and is written to the FIFO 268 for the optional area. A  
15 read timing controller 269 controls switches 266 and 267 to selectively switch, onto one signal line, the VAUX data in memory 265 for the main area and the VAUX data in FIFO 268 for the optional area, thereby synthesizing the VAUXDT and VAUXER data provided to signal processing microcomputer 251 (Fig. 30).

20 Signal Processing Microcomputer

25 The VAUXDT and VAUXER data generated by VAUX circuit 248, as described with reference to Fig. 31, are sent to the signal processing microcomputer 251 shown in more detail in Fig. 32. It will be recalled that the VAUXDT data is the VAUX data after pre-processing, such as the pre-hold processing which

corrects an error by holding previously stored VAUX data, thereby replacing currently stored erroneous VAUX data. The VAUXER data represents an error correction value left-over after the pre-processing of the VAUX data.

5           The VAUXDT data is sent to a pack header identifying circuit 271 which controls switch 272 to selectively couple the VAUXDT data to the memory blocks (60h ... 65h) of memory 272 according to the pack header identified by the pack header identifying circuit. When the VAUXER data indicates that the  
10 VAUXDT data is left uncorrected by the pre-processing of the VAUX circuit 248, a read/write circuit 273 prevents switch 272 from coupling the VAUXDT data to any of the memory blocks in memory 272.

15           It will be appreciated that the VAUX circuit 248 (Fig. 31) has already recombined the pack data from the main area and optional area packs. Therefore, it is not necessary for the signal processing microcomputer of Fig. 32 to distinguish between main area and optional area data packs. Accordingly, data packs for both the main area and optional area are stored in the same  
20 memory blocks of memory 272.

25           When the ERROR flag = "1", for example, meaning that an error has been detected, read/write circuit 273 inhibits the writing of the VAUXDT data to memory blocks of memory 272. When the VAUXDT data corresponds to main area data packs, wherein the data packs are stored in the main area a multiple of times, an

error in one of the data blocks is corrected by replacing the erroneous data block with another error-free data block. This can be done for the data blocks in the main area because these data blocks are considered correlated with the corresponding data blocks in the previous frame. On the other hand, the optional area data blocks are not considered correlated with the corresponding optional area data blocks in the previous frame. Accordingly, the error propagating process must be relied upon to error correct each optional area data pack individually.

10           The error correction method for the main area data packs is initiated by changing all of the erroneous data packs into "Ffh", meaning a pack with "no information" for data packs having a 5-byte fixed length. Main area data packs generally correspond to each other and an error-free data pack in the main area can replace an erroneous main area data pack. For example, TELTEXT data representing textual data includes many data packs of the textual data chained together. Since the pack headers in each of the packs for the TELTEXT data are the same, an erroneous pack header for this data may be easily replaced with another pack header. On the other hand, if the error takes place in the data section, thereby corrupting the textual data itself, there are generally no other data packs that correlate to the corrupted data pack and the error cannot be corrected by changing the erroneous data pack to a pack with "no information". In this latter situation, the erroneous data block is left intact and

sent to a TELTEXT decoder which error corrects the erroneous textual data block.

Assuming that the foregoing error correction process has not set the ERROR flag to indicate an error, the VAUXDT data is converted by parallel/serial converting circuit 274 (Fig. 32) into serial data and transmitted along an intra-microcomputer communication protocol line to mode processing microcomputer 217 as shown in Fig. 32. The mode processing microcomputer receives the transmitted serial data from the signal processing microcomputer and converts this serial data back into parallel form by use of a serial/parallel converting circuit 275. The pack data so converted into parallel bits is decomposed and analyzed by an analyzing section 276. The analyzing process is the reverse of the process of generating the pack data in mode processing microcomputer 34 provided in the foregoing recording circuit (Fig. 20).

It will be appreciated that the MIC microcomputer 219 of the reproducing circuit performs the reverse functions of the MIC microcomputer 38 of the recording circuit in Fig. 20. Accordingly, a duplicate description of MIC microcomputer 219 for the reproducing circuit is not provided.

#### Digital Bus Application for Dubbing

The present invention is particularly applicable to a digital VTR that uses a digital bus scheme. As shown in Fig. 33, the digital VTR includes a reproducing circuit 300 and a

recording VTR circuit 400 which have been simplified in the figure for purposes of this description. The reproducing and the recording circuit communicate over a digital bus represented by the dashed-line therebetween.

5           The reproducing VTR 300 includes an error interpolation circuit 301 and a packeting circuit 302 to produce transmission packets for transmission over the digital bus. It will be appreciated that the reproduced data from the record medium may include errors that even the foregoing error correction process  
10           may not be able to correct. Accordingly, the error interpolation circuit is provided to interpolate otherwise uncorrectable data.

          The error interpolating circuit 301, upon detecting the ERROR flag, thus determining that an error in the data packs exists, awaits an error-free data pack. In the case of the main  
15           area data packs, the error interpolation circuit may await several main area data packs before encountering the error-free data pack. When the error-free data pack is received by the error interpolation circuit, this circuit interpolates data from this error-free data pack and inserts this interpolated data into  
20           the erroneous data packs.

          In the situation where the data pack is not written many times, such as the optional area data packs, it is fruitless for the error interpolation circuit 301 to await an error-free data pack because the data packs do not correlate and an  
25           interpolation from these non-correlative data packs would be

inaccurate. In this latter situation, the erroneous data is replaced with the data set forth below to report that an error has taken place and is uncorrected. This replacement data is inserted as many times as there are erroneous data packs so long  
5 as the data packs do not correlate.

Audio Data (for 16 bits)

1000 0000 0000 0000

Audio Data (for 8 Bits)

1000 0000 0000 0000

10

Video Data (DC Component of DCT)

1000 0000 0000 0110

Pack Structure

No Info pack

The pack data thus error-interpolated by error  
15 interpolation circuit 301 is packed into packets by packeting circuit 302 for transmission. Then, the packets are supplied to a transmission error correcting code generating circuit 303 which adds parity data to the packeted data for correcting an error in transmission over the digital bus. The packets and parity data  
20 are, then sent to a driver circuit 304 to buffer the error protected data to the digital bus.

The data transmitted over the digital bus 305 is received by receiver 401 in the recording VTR 400 and supplied to a transmission error correction circuit 402 which error corrects the received digital bus data according to the parity inserted

therein. The error corrected digital bus data is, then, sent to an unpacking circuit 403 to unpack the digital bus data from the packets formed by packeting circuit 302. If an error still exists after error correction by transmission error correction circuit 402, the corresponding digital bus packets are considered as error data and the error correction process described above is performed.

A switch 404 receives the unpacketed data from unpacketing circuit 403 and separates therefrom the audio, video and system data. The position of the system data within the digital bus data is predetermined and switch 404 selects the system data by switching the unpacketed digital bus data from unpacketing circuit 403 to mode processing microcomputer 217 of the recording VTR. The mode processing microcomputer employs the system data to carry out operations of the VTR. The audio and video data, on the other hand, are selected by switch 404 and sent thereby to a delay circuit 405. The delay circuit delays a selected audio or video data by a delay amount corresponding to the processing time of the signal processing microcomputer 20.

The delayed video/audio data delayed by delay circuit 405 is combined with data from the mode processing microcomputer by adder 406. The combined data is sent from switch 26 to the recording circuit of the recording VTR through error correcting code generating circuit 27. If a signal such as CGMS, for example, is used for prohibiting copying of the reproduced

program, the signal processing microcomputer 20 provides an indication thereof to the mode processing microcomputer 34. In response thereto, the mode processing microcomputer issues a command to the mechanical control microcomputer 28 to inhibit the  
5 operation of the recording mechanism, thereby disabling the recording of the TV broadcast program.

Although an illustrated embodiment of the invention has been described in detail herein with reference to the accompanying drawings, it is to be noted that the invention is  
10 not limited to that embodiment, and that various changes and modifications may be affected therein by one skilled in the art without departing from the scope and spirit of the invention which is intended to be defined by the appended claims.



C L A I M S

~~WHAT IS CLAIMED IS:~~ The claims defining the invention are as follows:

1. A method for copy protecting television broadcast program signals transmitted by a broadcasting system and received by a video recorder, said television broadcast program signals including a generation limiting signal, and said video recorder recording said television broadcast program signals as digital signals in a format reserving recording areas for accessory information relating to said format and reserving other recording areas for digital image signals, comprising steps of:

determining whether signals received for recording by said video recorder are the television broadcast program signals;

changing a state of said generation limiting signal to a copy protect state which inhibits copying of said television broadcast program signals when said signals received for recording are determined to be the television broadcast program signals; and

recording said copy protect state in said recording areas for said accessory information and recording digital image signals in said other recording areas.

2. The method according to claim 1, wherein said step of determining further comprises the step of sensing a specific signal inserted by said broadcasting system on a predetermined line of said television broadcast program signals which is indicative of television broadcasts.

3. The method according to claim 2, wherein said step of sensing senses said specific signal in lines 16, 17 or 18 of said signals received for recording.

4. The method according to claim 3, wherein the step of sensing senses a video interval test signal as said specific signal.

5. The method according to claim 3, wherein said step of sensing senses a video interval reference signal as said specific signal.

6. The method according to claim 2, wherein said signals received for recording are digital television signals; and said generation limiting signal is transmitted as vertical blanking information data of said digital television signals.

7. A video recorder for copy protecting television broadcast program signals transmitted by a broadcasting system and received by a video recorder, said television broadcast program signals including a generation limiting signal, and said video recorder being operable to record said television broadcast program signals in a format reserving recording areas for accessory information relating to said format and reserving other recording areas for digital image signals, comprising:

means for coding said input signals for recording in accordance with said format and for recording the coded input signals in said reserved other recording areas;



means for recording, in said recording areas reserved for said accessory information, a generation limiting signal for copy protecting said input signals to be recorded in said other recording areas;

means for determining whether said input signals are television broadcast program signals; and

means for changing a state of said generation limiting signal to be recorded in said recording areas reserved for said accessory information from a state allowing the input signals, once recorded, to be copied, to a state for copy protecting said input signals to prevent said input signals, once recorded, to be copied, when said means for determining determines said input signals are television broadcast program signals.

8. The video recorder according to claim 7, wherein said means for determining determines whether said input signals are television broadcast program signals by sensing a specific signal inserted by said broadcasting system on a predetermined line of said television broadcast program signals which is indicative of television broadcasts.

9. The video recorder according to claim 8, wherein said means for determining senses said specific signal in lines 16, 17 or 18 of said input signals.

10. The video recorder according to claim 9, wherein said means for determining senses a video interval test signal as said specific signal.

11. The video recorder according to claim 9, wherein said means for determining senses a video interval reference signal as said specific signal.

12. The video recorder according to claim 8, wherein said input signals are digital television signals; and said generation limiting signal is transmitted as vertical blanking information data of said digital television signals.

13. A video recorder/reproducer for copy protecting television broadcast program signals transmitted by a broadcasting system and received by a video recorder, said television broadcast program signals including a generation limiting signal, and being operable to record said television broadcast program signals in said video recorder format reserving recording areas for accessory information relating to said format and reserving other recording areas for digital image signals, said recorder being further operable to reproduce those signals which have been recorded in said format, said apparatus comprising:

means for coding said input signals for recording in accordance with said format and for recording the coded input signals in said reserved other areas;

means for recording, in said recording areas reserved for said accessory information, a generation limiting signal for copy protecting said input signals to be recorded in said other recording areas;

means for determining whether said input signals are television broadcast program signals;

means for changing a state of said generation limiting signal to be recorded in said recording areas reserved for said accessory information from a state allowing the input signals, once recorded, to be copied, to a state for copy protecting said input signals to prevent said input signals, once recorded, to be copied, when said means for determining determines said input signals are television broadcast program signals;

means for reproducing the recorded input signals and the recorded accessory information, including said generation limiting signal; and

means for inserting said generation limiting signal into television signals derived from the reproduced signals when said generation limiting signal reproduced from said recording areas reserved for said accessory information is set to inhibit copying, and for changing the state of said reproduced generation limiting signal from a state allowing copying to a state for preventing copying and inserting the changed generation limiting signal into said derived television signals, when said reproduced generation limiting signal indicates copy protection of the reproduced input signals.

14. The video recorder according to claim 13, wherein said means for determining determines whether said input signals are television broadcast program signals by sensing a specific

signal inserted by said broadcasting system on a predetermined line of said television broadcast program signals which is indicative of television broadcasts.

15. The video recorder according to claim 14, wherein said means for determining senses said specific signal in lines 16, 17 or 18 of said input signals.

16. The video recorder according to claim 15, wherein said means for determining senses a video interval test signal as said specific signal.

17. The video recorder according to claim 15, wherein said means for determining senses a video interval reference signal as said specific signal.

18. The video recorder according to claim 14, wherein said input signals are digital television signals; and said generation limiting signal is transmitted as vertical blanking information data of said digital television signals.

19. A video reproducer for reproducing copy protected television broadcast program signals which include said television broadcast program signals having been recorded as digital video signals in respective video areas of a record medium and related accessory information in other areas reserved therefor, with said accessory information including generation limiting data derived from the generation limiting signal included in said television broadcast program signals, said apparatus comprising:

means for reproducing said digital video signals and said generation limiting data from said record medium;

means responsive to the reproduced generation limiting data for generating and inserting generation limiting signal into television signals derived from the reproduced digital video signals when said reproduced generation limiting data is set to a copy protecting state;

means for changing the reproduced generation limiting data from a condition allowing copying to a condition that prevents copying; and

means for generating and inserting a changed generation limiting signal into said derived television signals when said reproduced generation limiting data indicates copy protection of the reproduced digital video signals.

20. Apparatus substantially as described herein with reference to the accompanying drawings.

21. Method substantially as described herein with reference to the accompanying drawings.

**DATED this TWENTY THIRD day of SEPTEMBER 1996**

**Sony Corporation**

**Patent Attorneys for the Applicant**

**SPRUSON & FERGUSON**

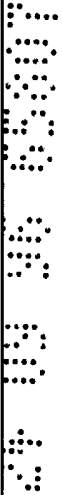

101006 03007

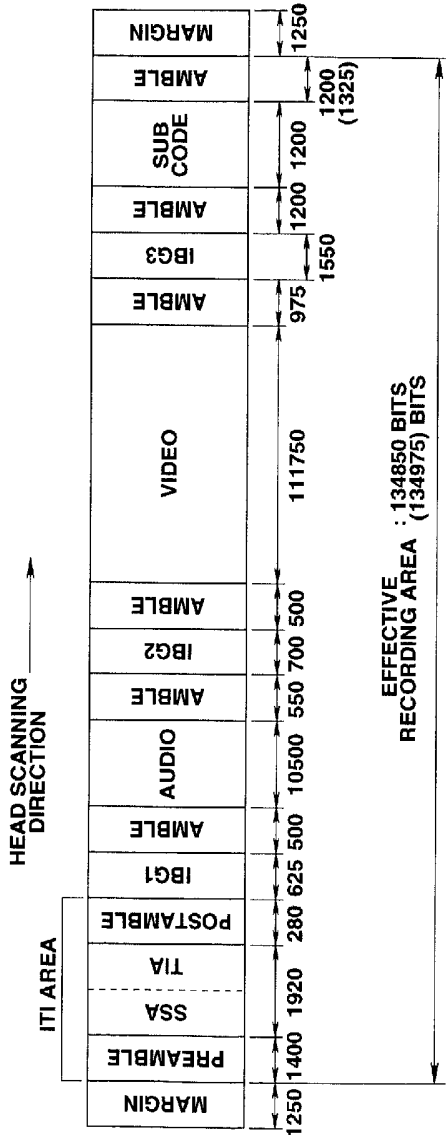

FIG.1

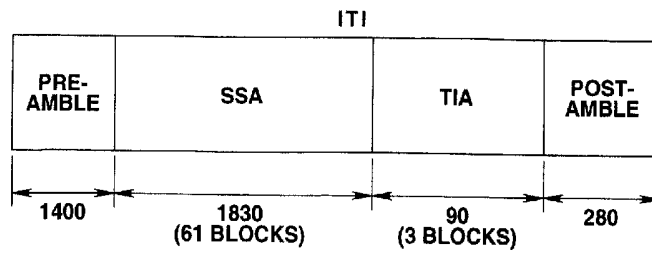

FIG.2

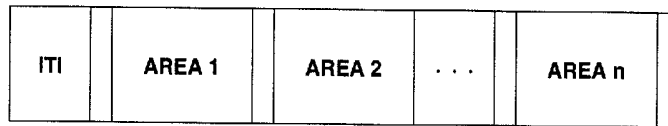

FIG.3

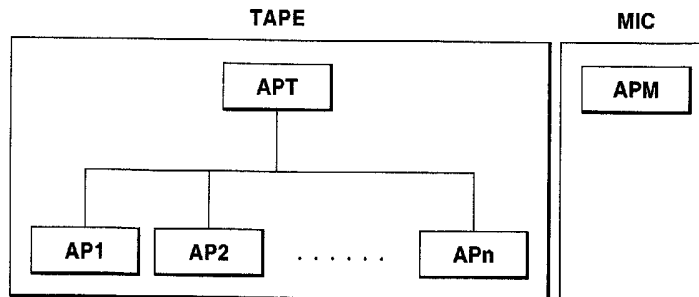

FIG.4

5050



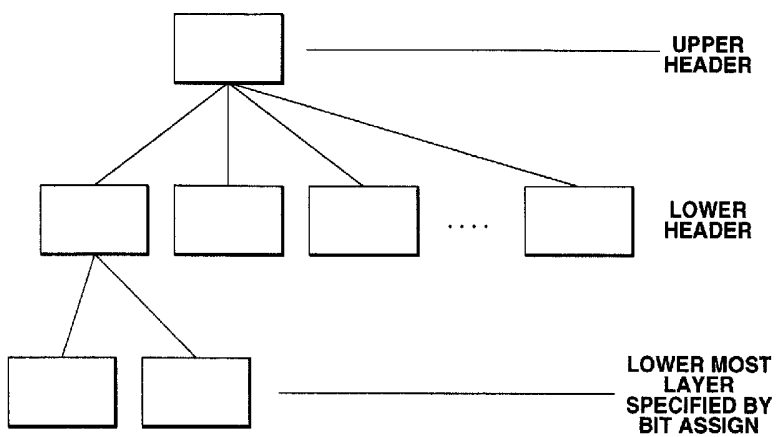

FIG.7

SECRET



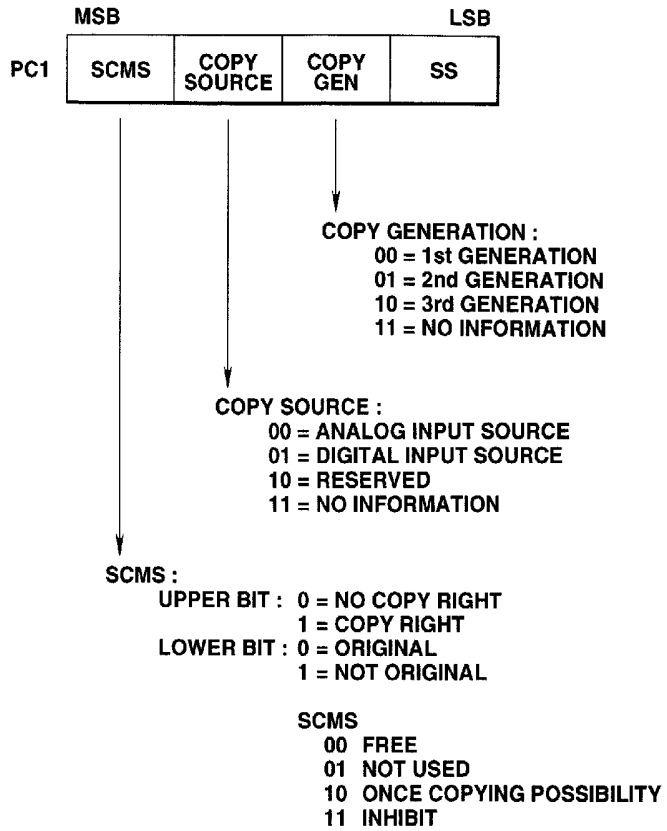
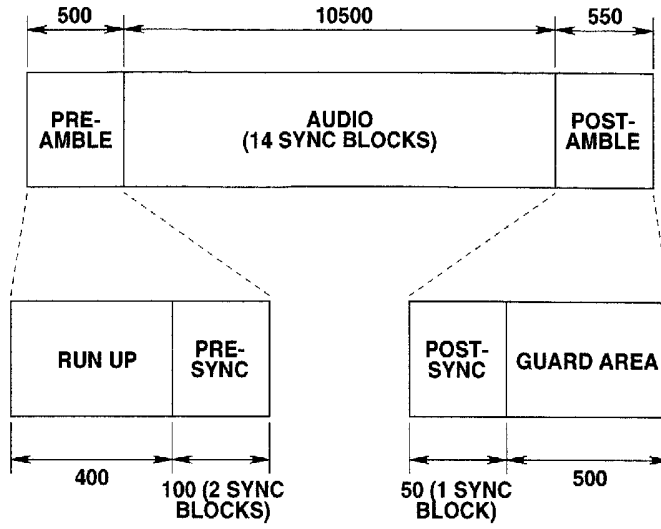
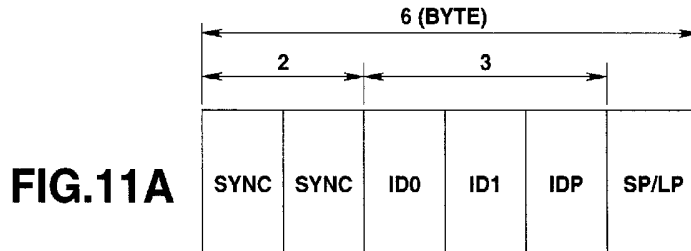

FIG.9

5  
5  
5  
5  
5



**FIG.10**



**FIG.11A**

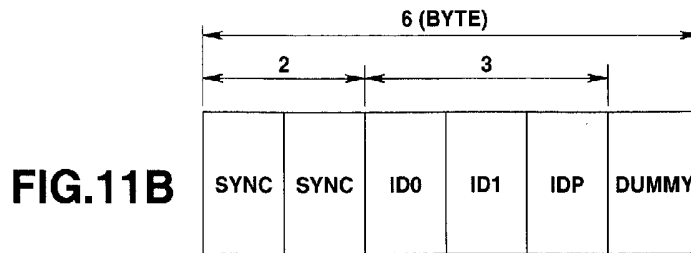

**FIG.11B**

5050  
 5050  
 5050

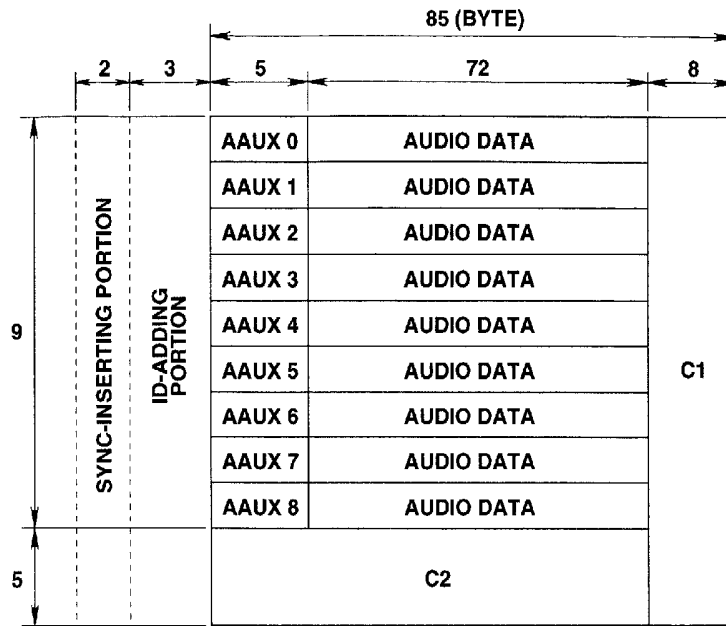

FIG.12A

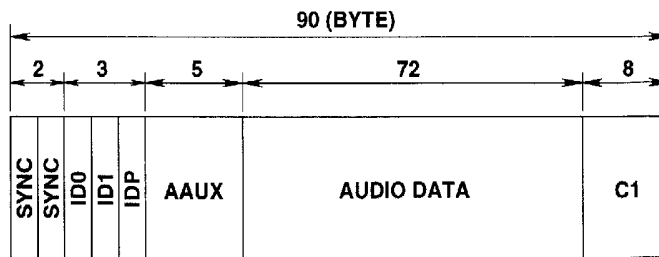

FIG.12B

101098 0303

TRACK NUMBER →	1	2	3	4	5	6	7	8	9	10
8	55	f ↑	55	↑	55	↑	55	↑	55	↑
7	54	e ↓	54	↓	54	↓	54	↓	54	↓
6	53	d ↓	53	↓	53	↓	53	↓	53	↓
5	52	55	52	55	52	55	52	55	52	55
4	51	54	51	54	51	54	51	54	51	54
3	50	53	50	53	50	53	50	53	50	53
2	c ↑	52	i ↑	52	↑	52	↑	52	↑	52
1	b ↓	51	h ↓	51	↓	51	↓	51	↓	51
0	a ↓	50	g ↓	50	↓	50	↓	50	↓	50

↑  
PACK NUMBER

5  
5  
5  
5  
5

FIG.13



VAUX SOURCE CONT PACK

PC0	0	1	1	0	0	0	0	1
PC1	SCMS/ CGMS		COPY SOURCE		COPY GEN		SS	
PC2	REC ST	1	REC MODE		1	DISP		
PC3	FF	FS	FC	IL	ST	SC	BCSYS	
PC4	RI	GENRE CATEGORY						

**COPY SOURCE :**  
 00 = ANALOG INPUT  
 01 = DIGITAL INPUT  
 10 = RESERVED  
 11 = NO INFORMATION

**COPY GENERATION :**  
 00 = 1st GENERATION  
 01 = 2nd GENERATION  
 10 = 3rd GENERATION  
 11 = NO INFORMATION

**FIG.15**

505040

# 10101010 00001010

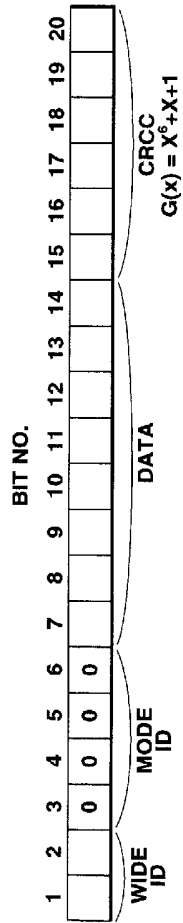

WIDE ID

BIT1 : TRANSMISSION ASPECT RATIO

BIT2 : PICTURE DISPLAY FORMAT

	1	0
BIT 1	16 : 9	4 : 3
BIT 2	LETTER BOX	NORMAL

SCMS

MODE ID = 0000

BIT7 : COPYRIGHT  
 BIT8 : GENERATION TO BE COPIED  
 ANY EXCEPT THE ABOVE : UNDEFINED

BIT7 : 0 = NO COPY RIGHT  
 1 = COPY RIGHT  
 BIT8 : 0 = ORIGINAL  
 1 = NOT ORIGINAL

FIG.16

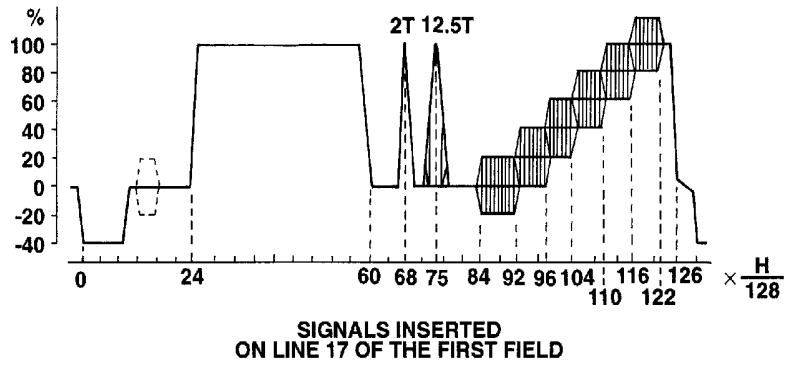

FIG.17A

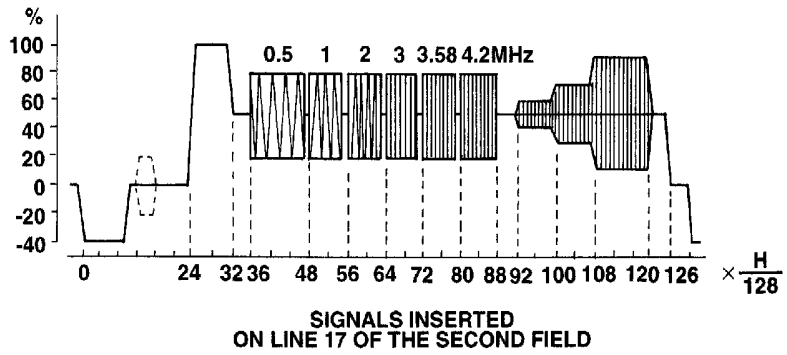

FIG.17B

5  
5  
5  
5  
5

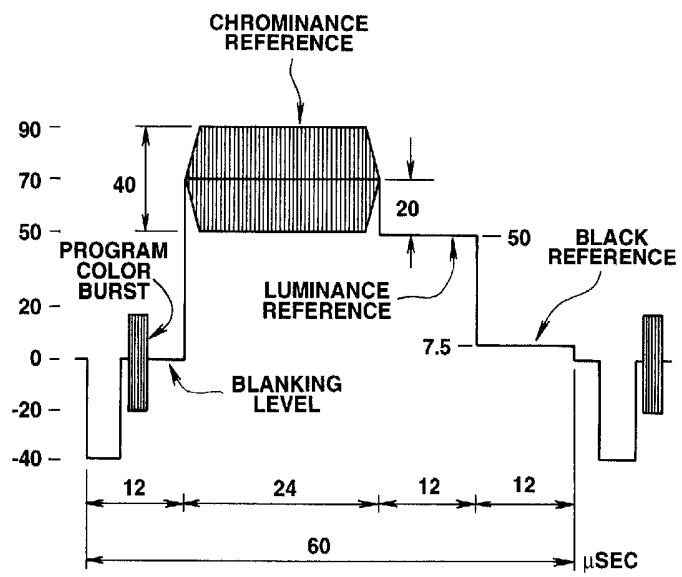

FIG.18

SECRET

0000000000

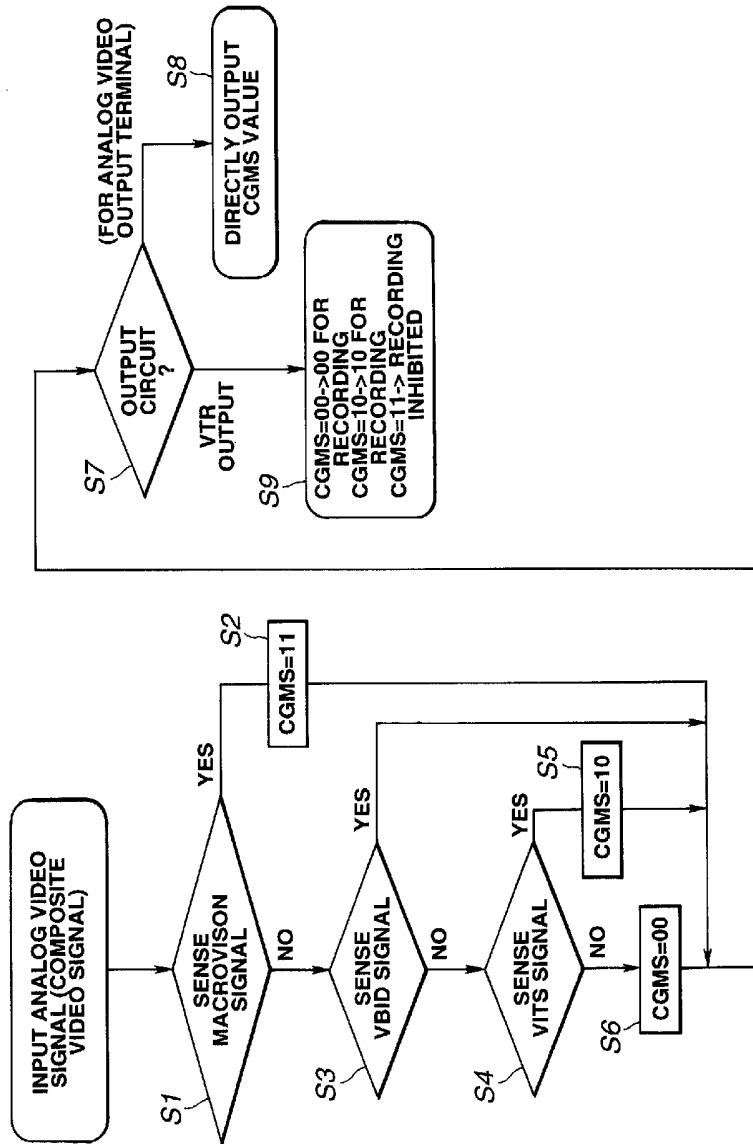

FIG.19

# FIG. 20

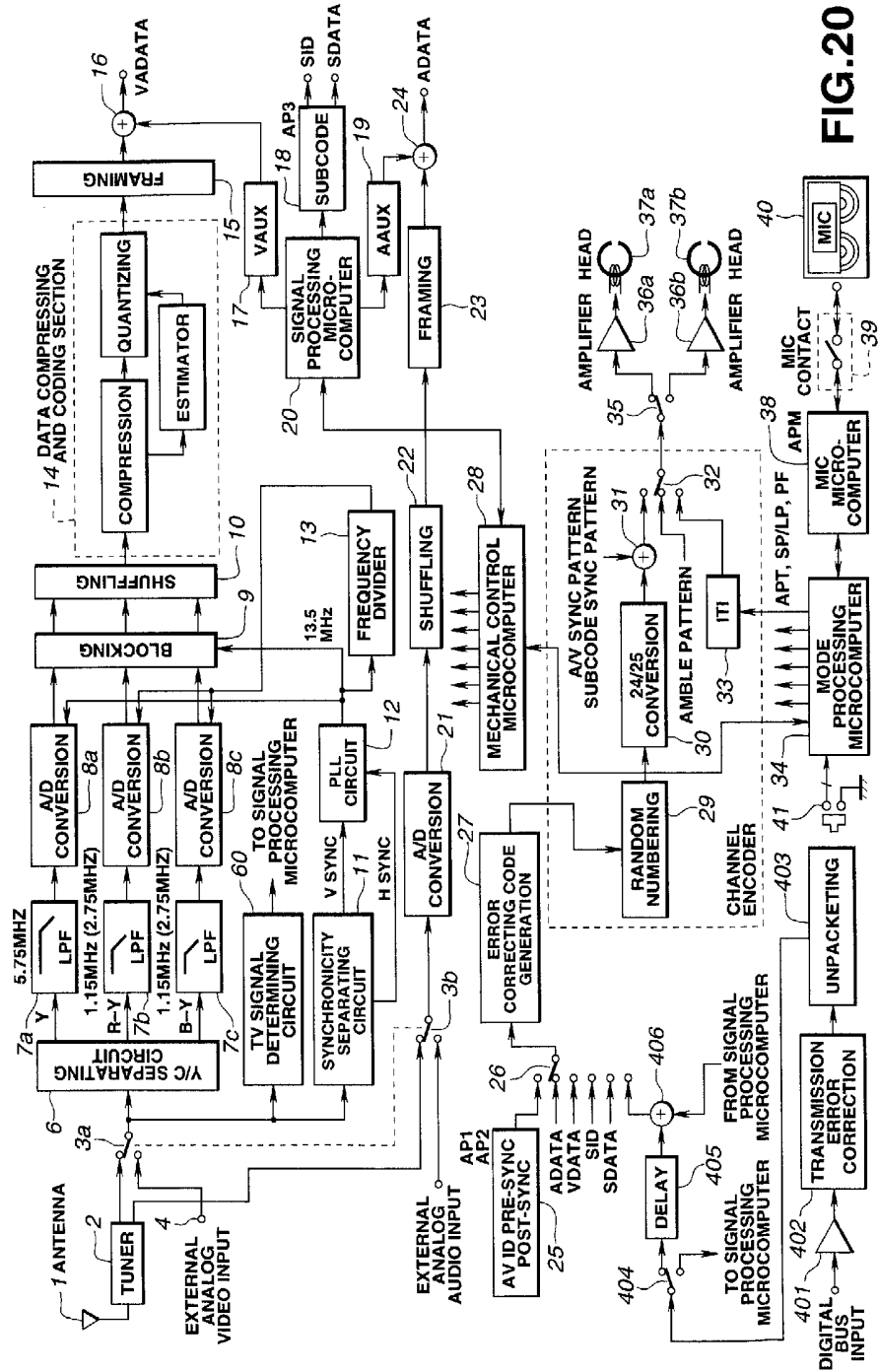

FIG. 20

10105 0007

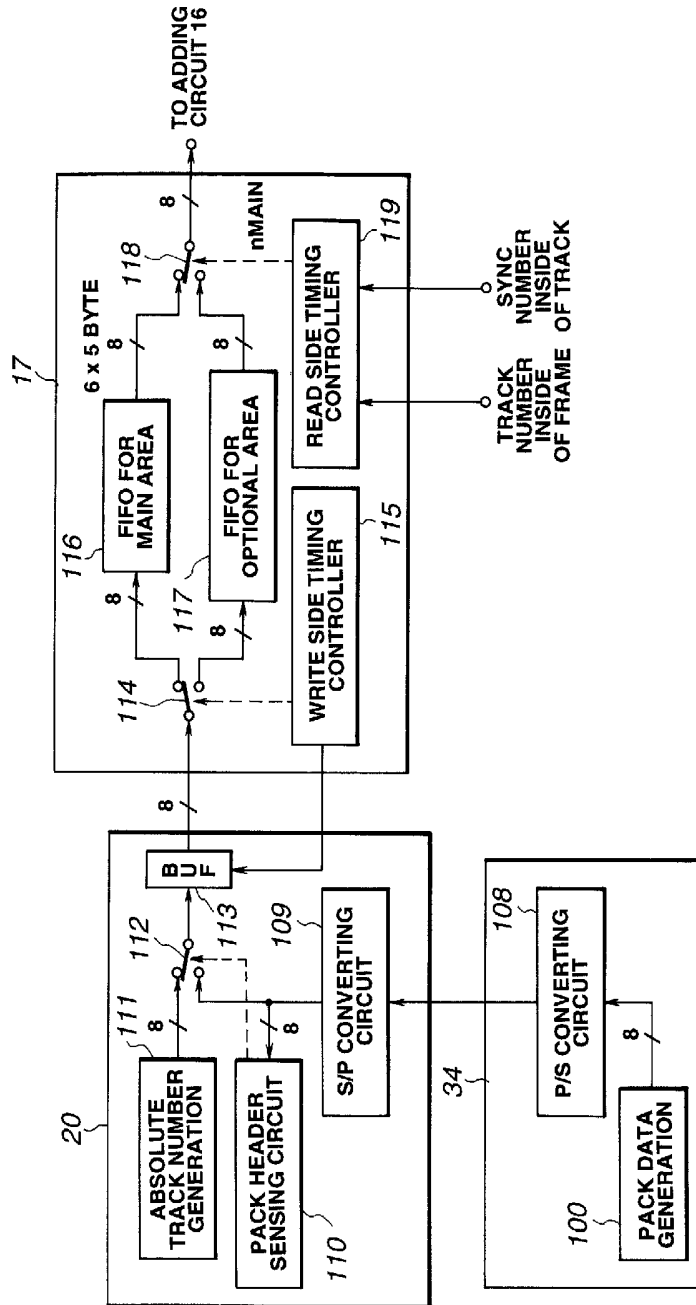

FIG. 21

10106 0007

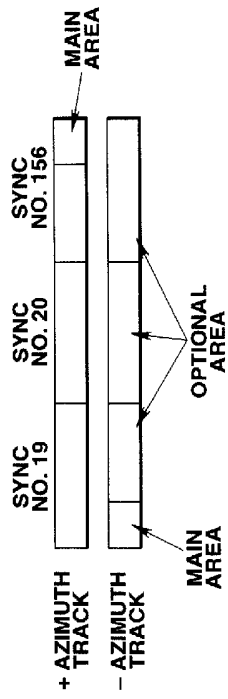

FIG.22A

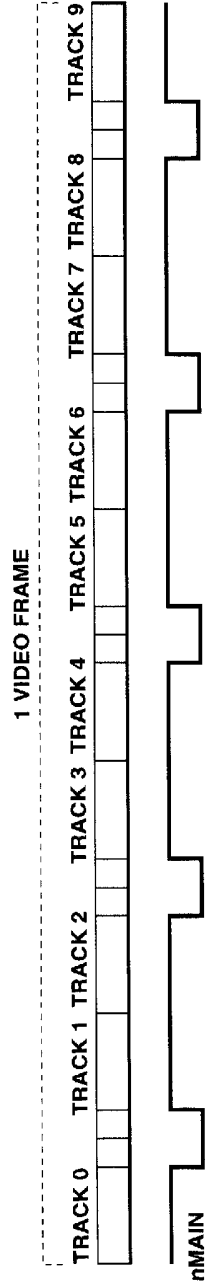

FIG.22B

1005 0001

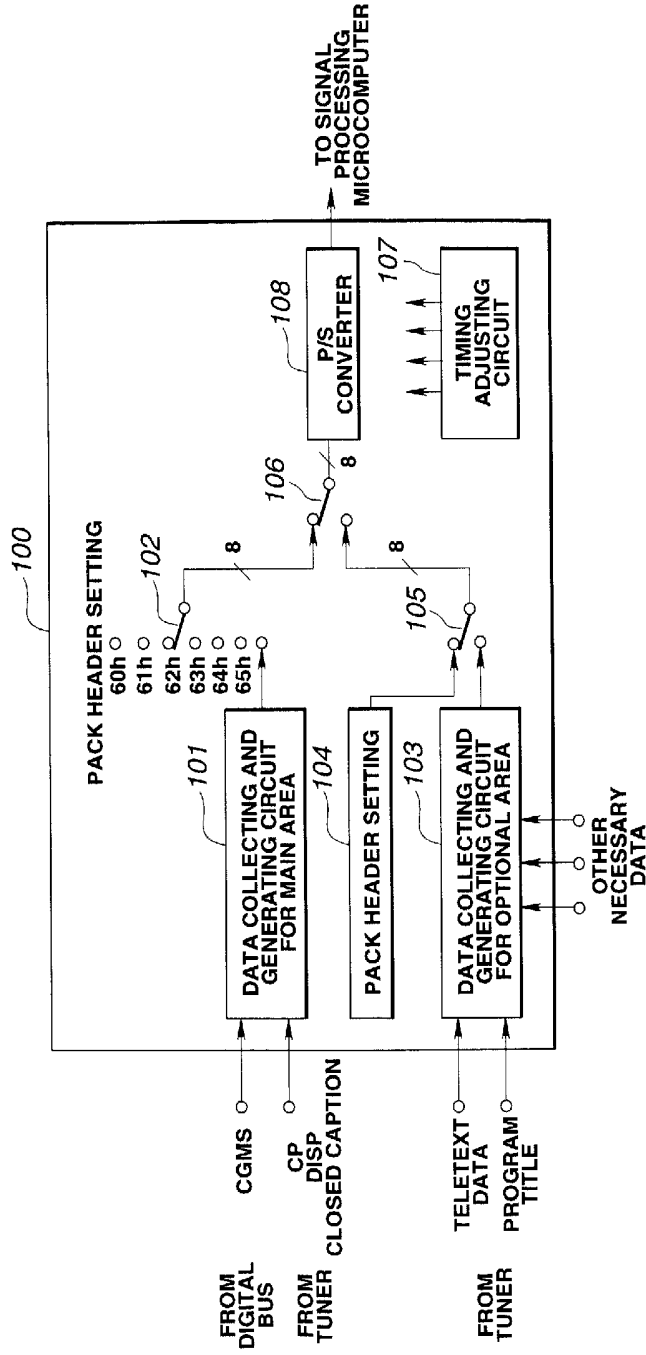

FIG. 23

**GENERATION DATA FOR MAIN AREA**

**TV CHANNEL**

**BW,EN,CLF**

**SOURCE CODE, 50/60, STYPE**

**TUNER CATEGORY**

**COPY SOURCE, COPY GEN, CI**

**REC ST, REC MODE, FF, FS, FC, IL, ST, SC**

**GENRE CATEGORY**

**REC DATE**

**REC TIME**

**BINARY GROUP**

**FIG.24**

50

50



**GENERATION DATA FOR MAIN AREA**

LF, CH, PA  
EF, TC, 50/60, STYPE  
TUNER CATEGORY

COPY SOURCE, COPY GEN, CI  
REC ST, REC END, REC MODE  
INSERT CH, DRF, SPEED  
GENRE CATEGORY

REC DATE  
REC TIME  
BINARY GROUP

**FIG.26**

5050  
5050

101095 5303

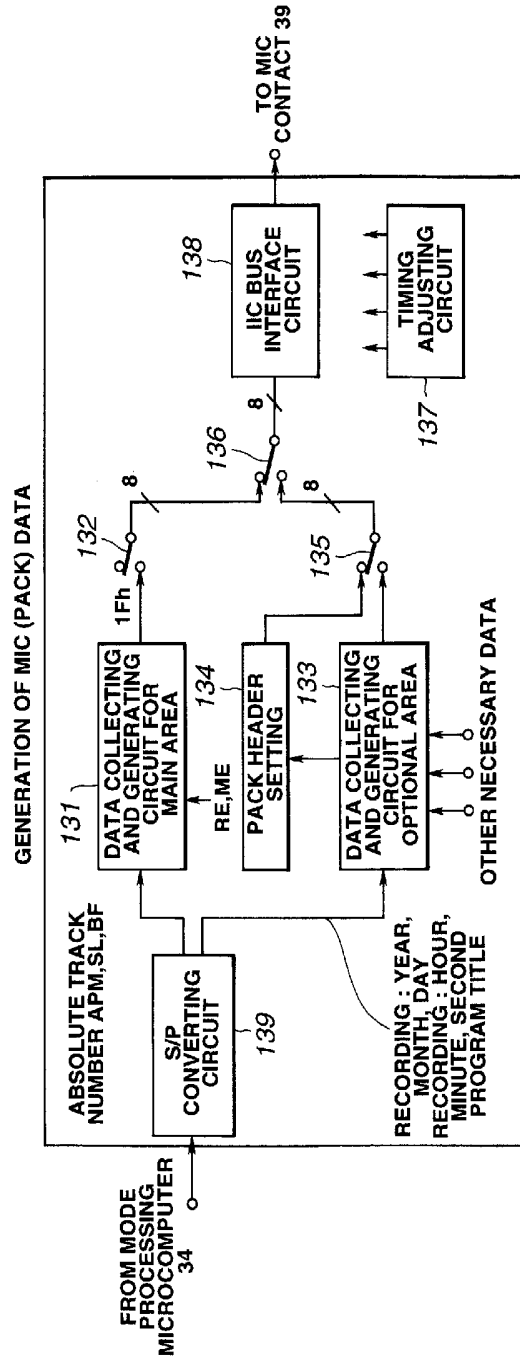

FIG.27



# TIME BASE CORRECTOR

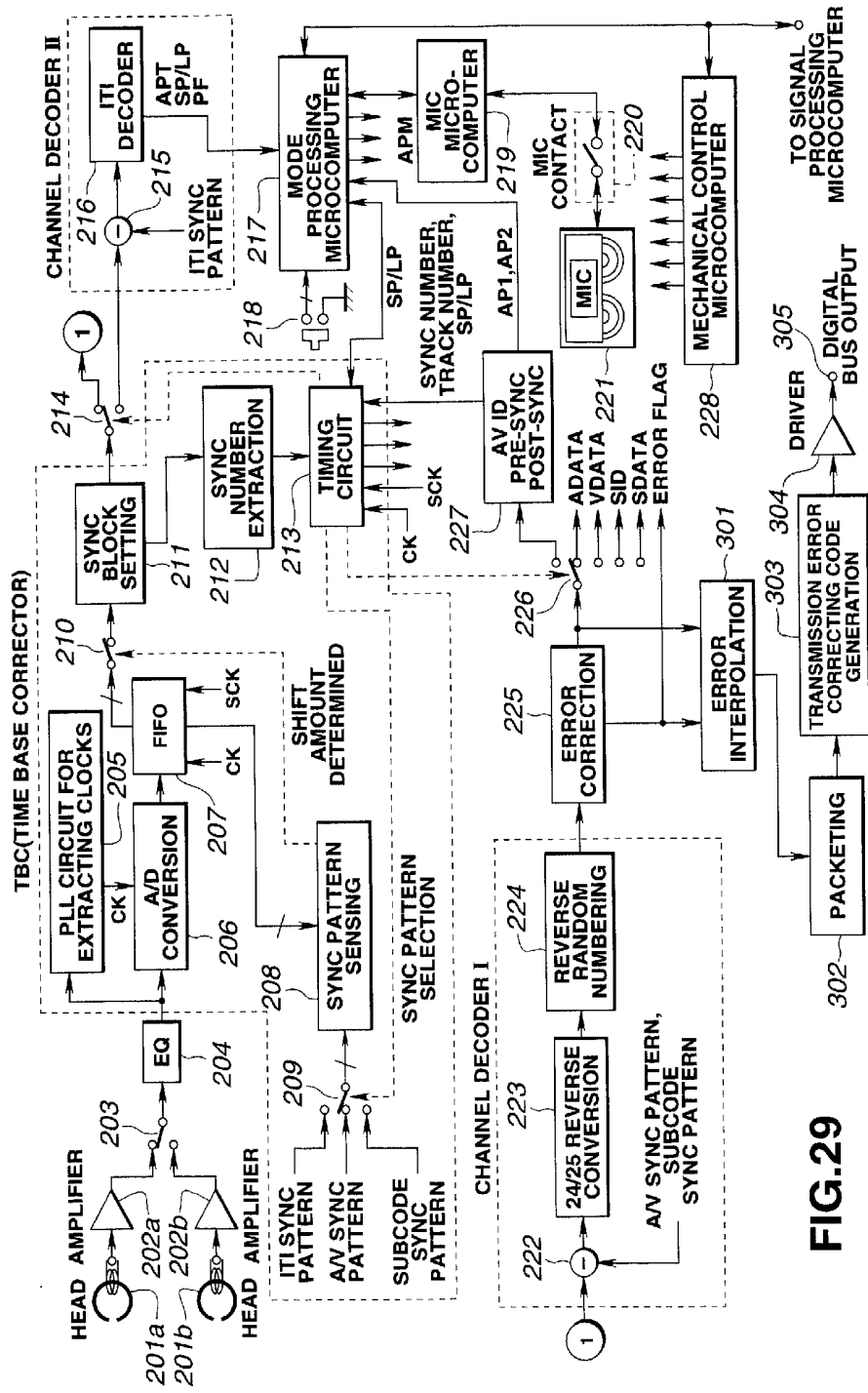

FIG.29

01000000

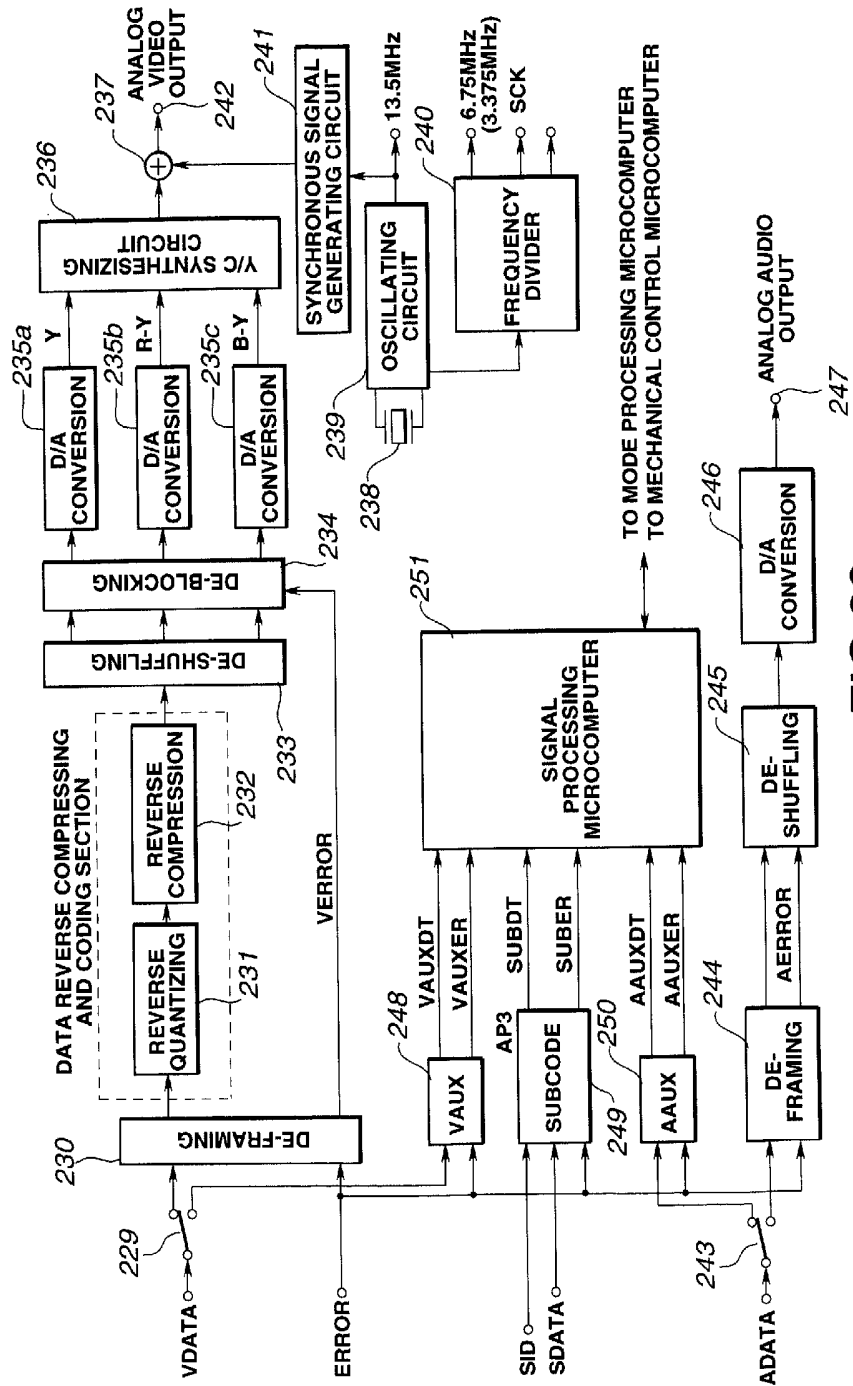

FIG.30

101006 63007

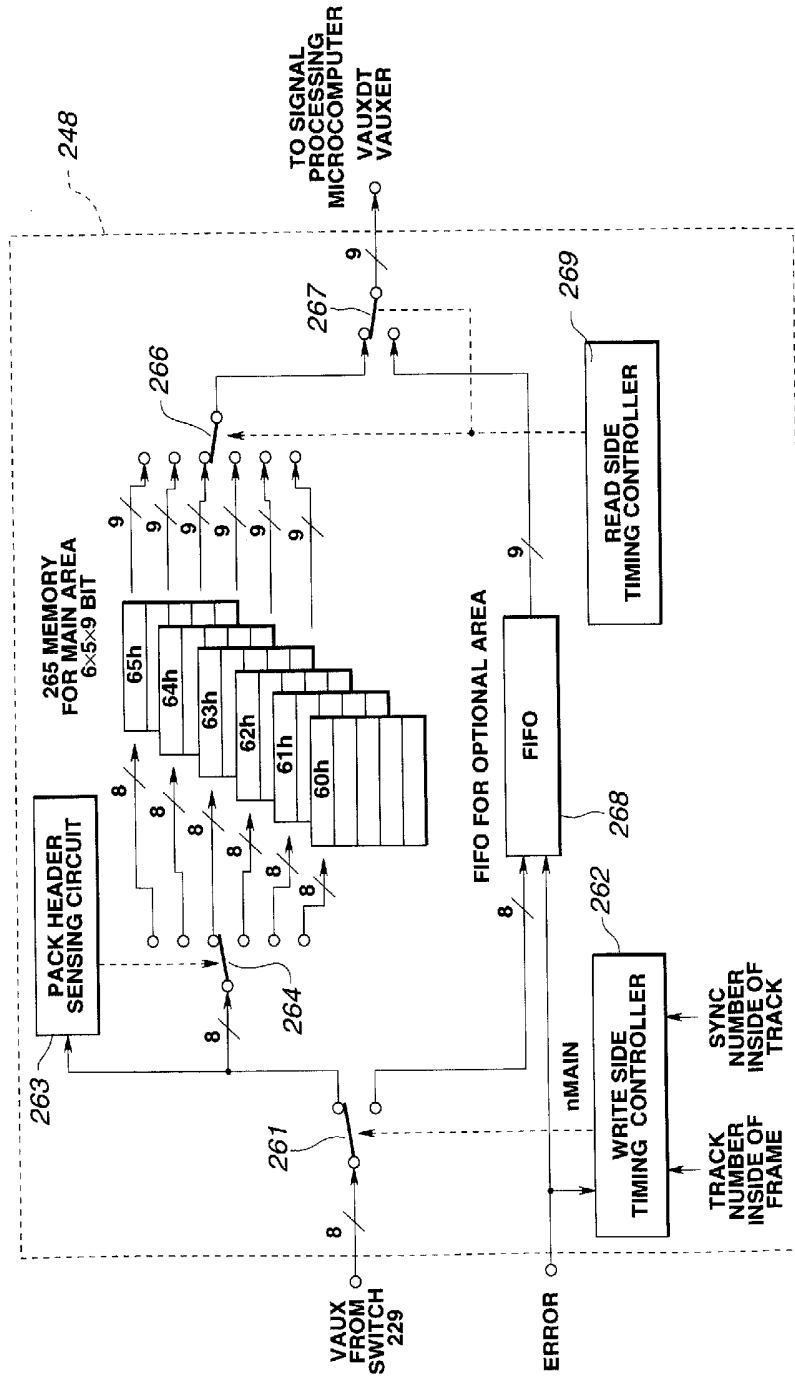

FIG. 31

101006 83007

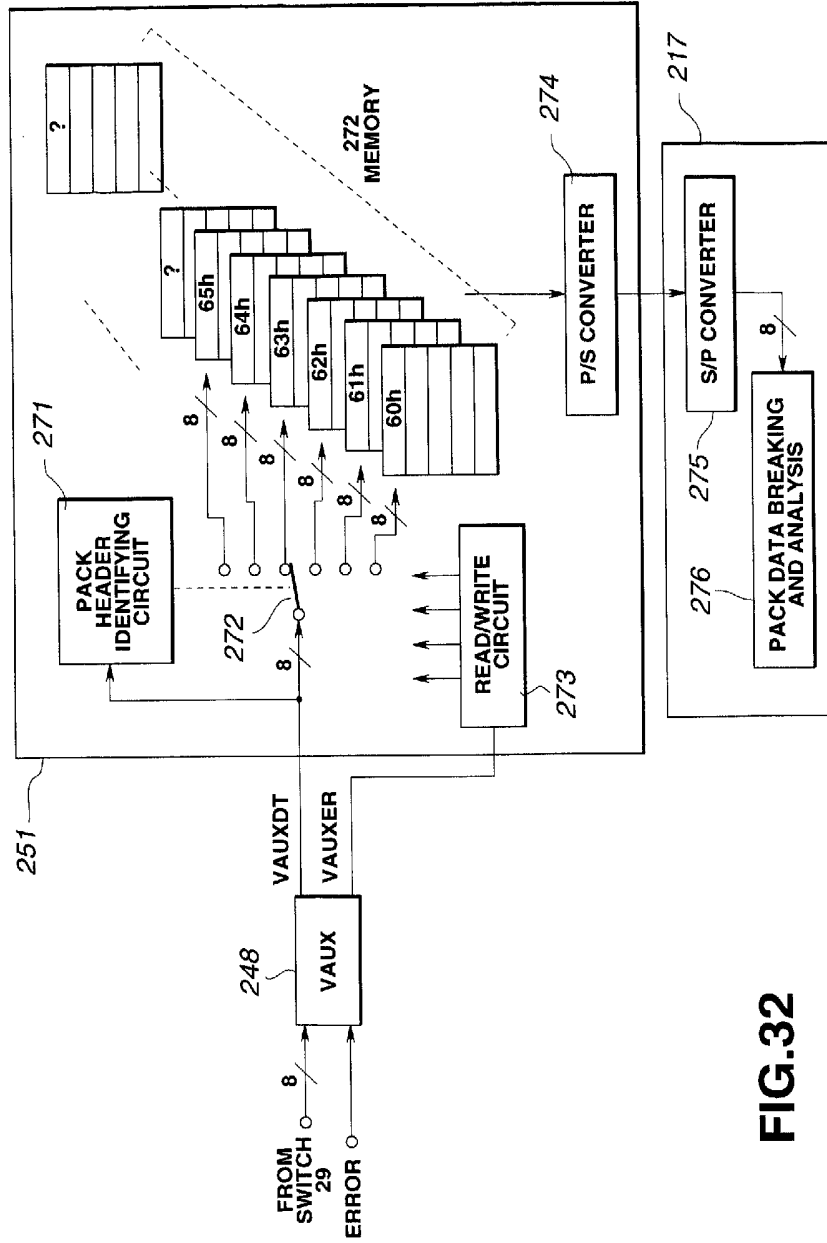

FIG.32

# FIG. 33

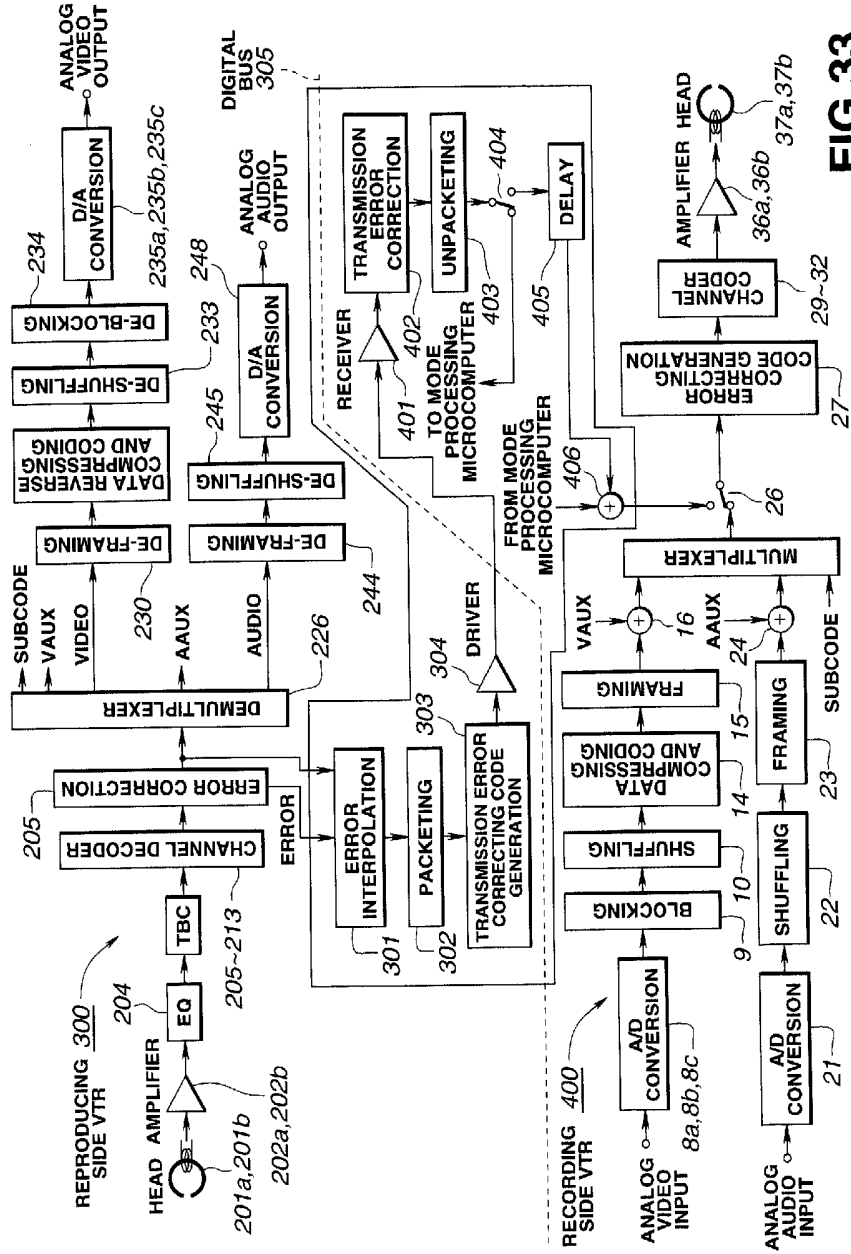

FIG. 33