

J. C. BUTLER.
MOTOR.

No. 190,818.

Patented May 15, 1877.

Fig. 1.

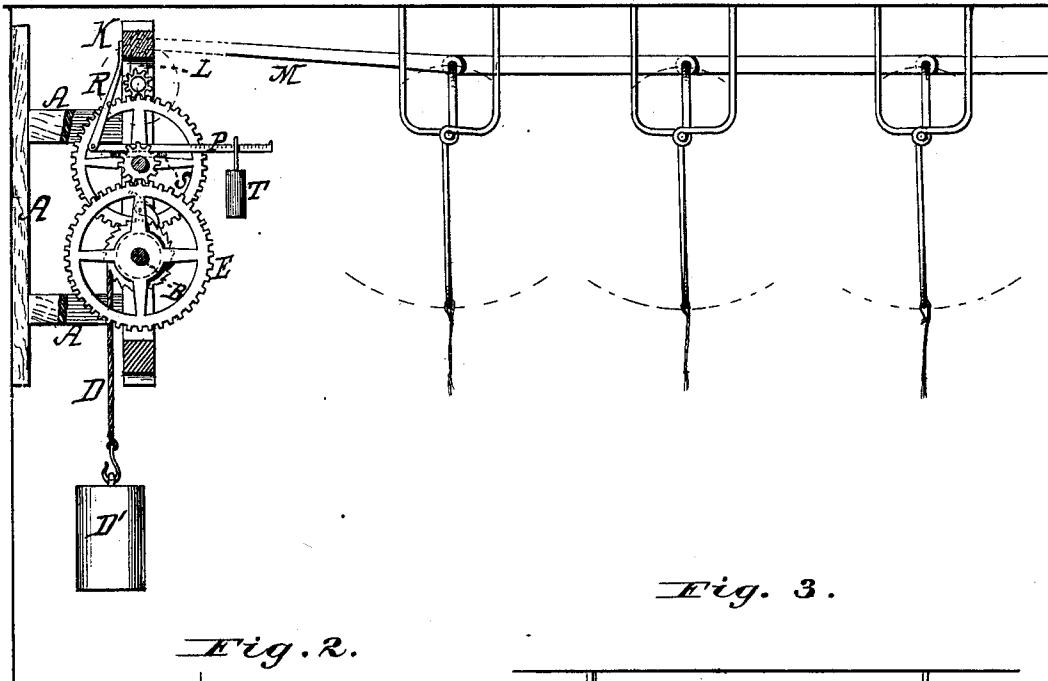

Fig. 3.

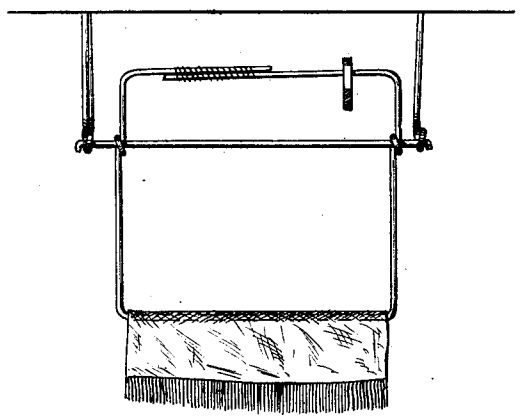
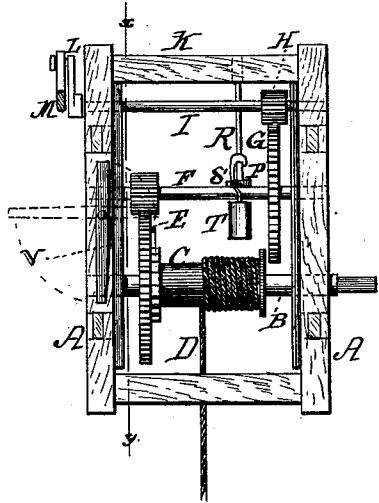

Fig. 2.



Attest:
Ed. Perrine
J. C. Rutherford

Jerry C Butler.
Inventor.
By James L. Norris.
Attorney

UNITED STATES PATENT OFFICE.

JEREMIAH C. BUTLER, OF GREENTON, ASSIGNOR OF ONE-HALF HIS RIGHT
TO JABEZ ELISHA SHOTWELL, OF LEXINGTON, MISSOURI.

IMPROVEMENT IN MOTORS.

Specification forming part of Letters Patent No. **190,818**, dated May 15, 1877; application filed
March 13, 1877.

To all whom it may concern:

Be it known that I, JEREMIAH C. BUTLER, of Greenton, in the county of La Fayette and State of Missouri, have invented certain new and useful Improvements in Motive Powers, of which the following is a specification:

This invention relates to an improved motive power for driving light machinery; and is particularly designed for driving the fans usually employed in warm weather in restaurants and other like places, although it may be employed, with advantage, for driving pumping machinery, churns, and the like.

My invention consists in a train of multiplying-gearing, driven by means of a weight attached, by a cord or chain, to the main shaft, and a regulator controlled, by means of an adjustable weight, in such manner as to regulate the speed and power transmitted to the machinery, in order to adapt the said motive power to be employed with any desired number of fans, pumps, or churns, as will be more fully hereinafter set forth.

In the accompanying drawings, Figure 1 is a side view of my motive power; Fig. 2, a front view of the driving mechanism; Fig. 3, a detached view of one of the fans.

In the present instance I have represented my improved motive power as employed for driving the fans usually employed in restaurants and other similar places in warm weather, for the purposes of ventilation and for driving away flies.

The letter A represents a framing, suitably located in respect to the fans, for supporting the various working parts of my motive power. B represents the main shaft of the motive power journaled in the frame A, and carrying a barrel or drum, C, to which one end of a cord or chain, D, is secured, the other end having attached thereto a weight, D', by means of which motion is imparted to the train of gearing. Said main shaft has secured to it a toothed or cogged wheel, E, which gears into a pinion on a shaft, F, journaled in frame A above said main shaft. Said shaft F carries a cogged or toothed

wheel, G, gearing in a pinion, H, on the shaft I, which is also journaled in the frame K, one end of said shaft being provided with a crank, L, to which one end of a rod or pitman, M, connected at the other end to the fan-levers N, is secured.

The letter P represents a lever, pivoted at one end to a hanger, R, secured to the frame A, and extending over the shaft F, said lever being provided with a brake, S, which bears against said shaft. The free end of said lever is graduated similarly to a scale-beam, and is provided with a movable or adjustable weight, T, by means of which the pressure of the brake upon the shaft F may be regulated, and the speed and power transmitted to the fans or other machinery varied and controlled.

The letter V represents a stop or detent, consisting of a lever pivoted to the frame A in such position that one end may be made to engage a tooth on the cogged wheel E, and arrest the motion of the machinery.

The advantages of my improved motive power will be apparent from the above description.

In all establishments where a number of light machines are employed it is seldom that all are in use at the same time, and for this reason it is desirable to adjust the driving power so as to drive any number at the proper rate of speed.

It will be evident from the above description that this can be conveniently and effectually accomplished by means of the adjustable weight upon the brake-lever.

In the present instance I have described and shown the driving-train as composed of a specified number of multiplying-wheels; but I do not intend to limit myself to such number, as more or less may be employed according to the nature of the work for which the apparatus is intended to be employed.

What I claim, and desire to secure by Letters Patent, is—

The combination of the supporting-frame A, the shaft B, journaled in the same, the drum C, mounted on said shaft, and pro-

vided with a cord or chain, D, and weight D', the wheels E and G, and pinions with which they gear, the shafts I and F, and crank L, the pivoted lever P, its brake S, and weight T, the whole constructed and arranged to operate substantially as set forth.

In testimony that I claim the foregoing I

have hereunto set my hand in the presence of the subscribing witnesses.

JEREMIAH CLOUD BUTLER.

Witnesses:

JABEZ ELISHA SHOTWELL,
JOHN EDWIN RYLAND.