

12

EUROPEAN PATENT APPLICATION

21 Application number: 84307146.5

51 Int. Cl.⁴: **H 01 R 13/10**

22 Date of filing: 17.10.84

30 Priority: 19.10.83 GB 8327993

43 Date of publication of application:
02.05.85 Bulletin 85/18

84 Designated Contracting States:
BE DE FR NL

71 Applicant: **The General Electric Company, p.l.c.**
1 Stanhope Gate
London W1A 1EH(GB)

72 Inventor: **Harcourt, Michael David**
57 Harold Road
Stoke Coventry, CV2 5LB(GB)

74 Representative: **Dolwin, John Davison**
Central Patent Department Wembley Office The General
Electric Company, p.l.c. Hirst Research Centre East Lane
Wembley Middlesex HA9 7PP(GB)

54 **Electric socket connectors.**

57 To reduce wear on the electrical contact-making surfaces of cooperating plug and socket connector contacts (5, 3) the contact pressure is made as light as possible, consistent with good electrical contact, and an extra member or finger (4) is provided on each socket contact (1) which bears on an area of the respective plug contact (5) not utilised for electrical connection with sufficient pressure to provide the required mechanical resistance to separation of the plug and socket connectors (7, 6). Where the plug contacts (5) are square-section pins the extra finger (4) of a socket contact may bear on a face of the respective pin which is transverse to the faces normally utilised for electrical connection.

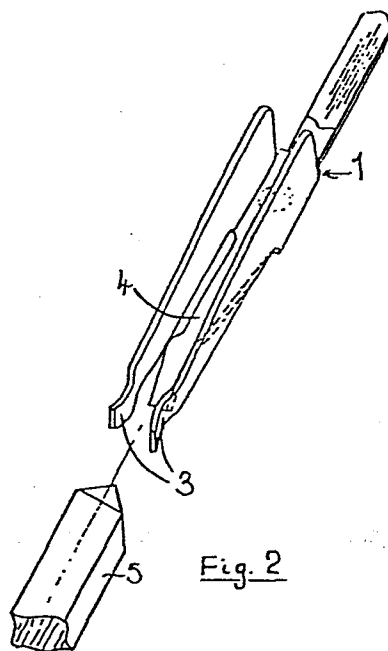

Fig. 2

EP U 139 525 A2

-1-

Electric Socket ConnectorsTEX/2223

The present invention relates to electric socket connectors.

In particular, although not exclusively the invention relates to electrical connectors of the kind
5 in which electrical connection with an associated plug contact is effected by means of a pair of opposed spring contacts bearing on opposite sides of said plug contact.

In telecommunications equipment, for example,
10 multiway connectors typically comprise associated plug and socket connectors each having a plurality of so-called male and female contacts respectively inserted into appropriately shaped injection mouldings of electrically insulating material. Each female contact may comprise
15 one or more cantilever springs of sufficient rate to provide an adequate force at the points of electrical contact with the associated male contact. At the same time the female contacts may be required to provide, often with the same cantilever springs, sufficient retention
20 forces to keep the plug and socket connectors in proper engagement.

It has been found that the magnitude of the forces required for retention can exceed those required for reliable electrical connection, and that repeated engage-
25 ment and disengagement with high forces results in a high rate of wear of the electrical contact area, degrading the contact performance to an unacceptable degree.

According to one aspect of the present invention in an electric socket connector in which an electrical connection between a contact of said socket connector and a contact of an associated plug connector is effected
5 by means of a resilient portion of said socket connector contact which is arranged to bear on said plug connector contact, there is provided on said socket connector contact at least one other resilient portion which is arranged to bear upon a surface of said plug
10 connector contact at a point other than that or those in which said electrical connection is effected when said plug and socket connectors are fully engaged.

According to another aspect of the present invention in an electric socket connector including
15 a plurality of socket contacts for effecting a like plurality of electrical connections with respective plug contacts of an associated plug connector, each socket contact comprising a pair of opposed resilient members arranged to bear on opposite sides of the respective plug
20 contact when the socket and plug connectors are fully engaged, there is provided on each socket contact at least one other resilient member which is arranged to bear upon the surface of the respective plug contact in an area other than those in which said electrical connection is
25 effected when said socket and plug connectors are fully engaged.

The resilient member may be arranged to bear on a surface of said plug contact substantially perpendicular to said opposite sides of the plug contact.

30 An electric socket connector in accordance with the present invention will now be described by way of example with reference to the accompanying drawing, of which:

35 Figures 1 and 2 respectively show a developed plan view and an isometric view of a contact of the connector, and

Figure 3 shows diagrammatically a socket connector and part of an associated plug connector.

Referring to the drawing each female or socket connector contact 1 is cut and formed from thin sheet metal, such as phosphor bronze, the cut shape shown in Figure 1 being bent at right angles along the dotted lines 2 to form two opposed cantilever springs 3 with a third cantilever spring 4 lying alongside and generally in a plane at right angles to the general planes of the springs 3. The springs 3 and 4 are curved adjacent their free ends to facilitate engagement with an associated substantially square-section plug contact 5 and to define respective contact areas which are arranged to bear upon that contact 5. The springs 3 are formed to exert comparatively low forces on the contact 5 sufficient to provide effective electrical connection, while the spring 4 is shorter and stiffer to provide the higher force necessary to keep the contacts in engagement.

This arrangement confines the higher rates of wear to faces of the contacts 5 that are not used to effect electrical connection, although of course in the arrangement shown the spring 4 will in general act as an electric contact in exactly the same manner as the springs 3.

It will be appreciated that the contacts 1 and 5 will in use be retained within respective socket and plug mouldings 6 and 7 which will determine which faces of the contact 5 are utilised primarily for electrical contact and which are primarily for retaining purposes. It will further be appreciated that the roles of the springs 3 and 4 may be reversed, with the springs 3 made stiffer to contribute the retaining forces and the spring 4 providing the light pressure electrical connection. Alternatively the contact 1 may be shaped so as to provide two springs 4 as well as two springs 3, these springs bearing in pairs on respective opposite faces of the contact 5.

The areas of the contacts 1 and 5 that are directly involved in effecting electrical connections may be plated

-4-

with precious metal such as gold to ensure good and reliable connection with low contact pressure. The plating may be restricted to those areas of the contacts directly involved in making electrical connection.

CLAIMS.

1. An electric socket connector in which an electrical connection between a contact of said socket connector and a contact of an associated plug connector is effected by means of a resilient portion of said socket connector
5 contact which is arranged to bear on said plug connector contact, wherein there is provided on said socket connector contact at least one other resilient portion which is arranged to bear upon a surface of said plug connector contact at a point other than that or those
10 in which said electrical connection is effected when said plug and socket connectors are fully engaged.
2. An electric socket connector including a plurality of socket contacts for effecting a like plurality of electrical connections with respective plug contacts of an
15 associated plug connector, each socket contact comprising a pair of opposed resilient members arranged to bear on opposite sides of the respective plug contact when the socket and plug connectors are fully engaged, wherein there is provided on each socket contact at least one other resilient
20 member which is arranged to bear upon the surface of the respective plug contact in an area other than those in which said electrical connection is effected when said socket and plug connectors are fully engaged.
3. An electric socket connector in accordance with
25 Claim 2 wherein the plug contacts of the associated plug connector are of substantially square section, and the other resilient member of each socket contact is arranged to bear on a surface of the respective plug contact which is substantially perpendicular to said opposite sides of said
30 plug contact.
4. An electric socket connector in accordance with Claim 2 wherein the electrical contact-making areas on said opposite sides of said plug contacts are plated with precious metal to ensure good and reliable electrical connection.

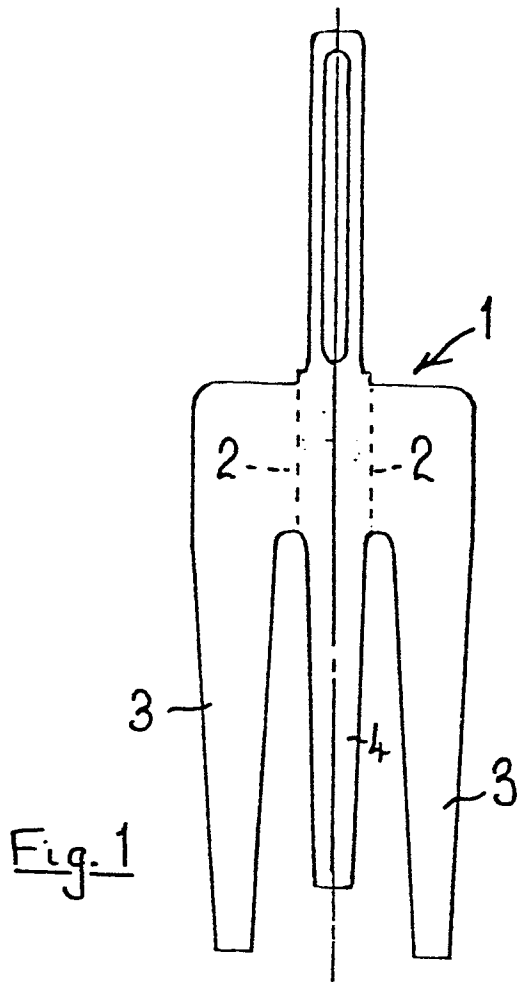

Fig. 1

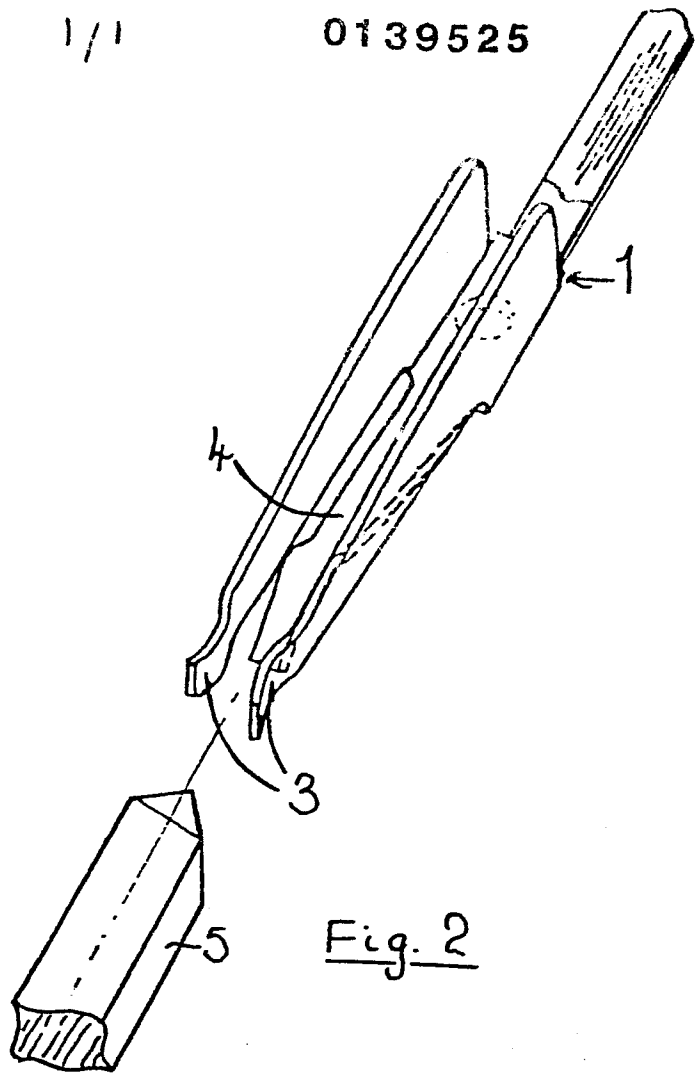

Fig. 2

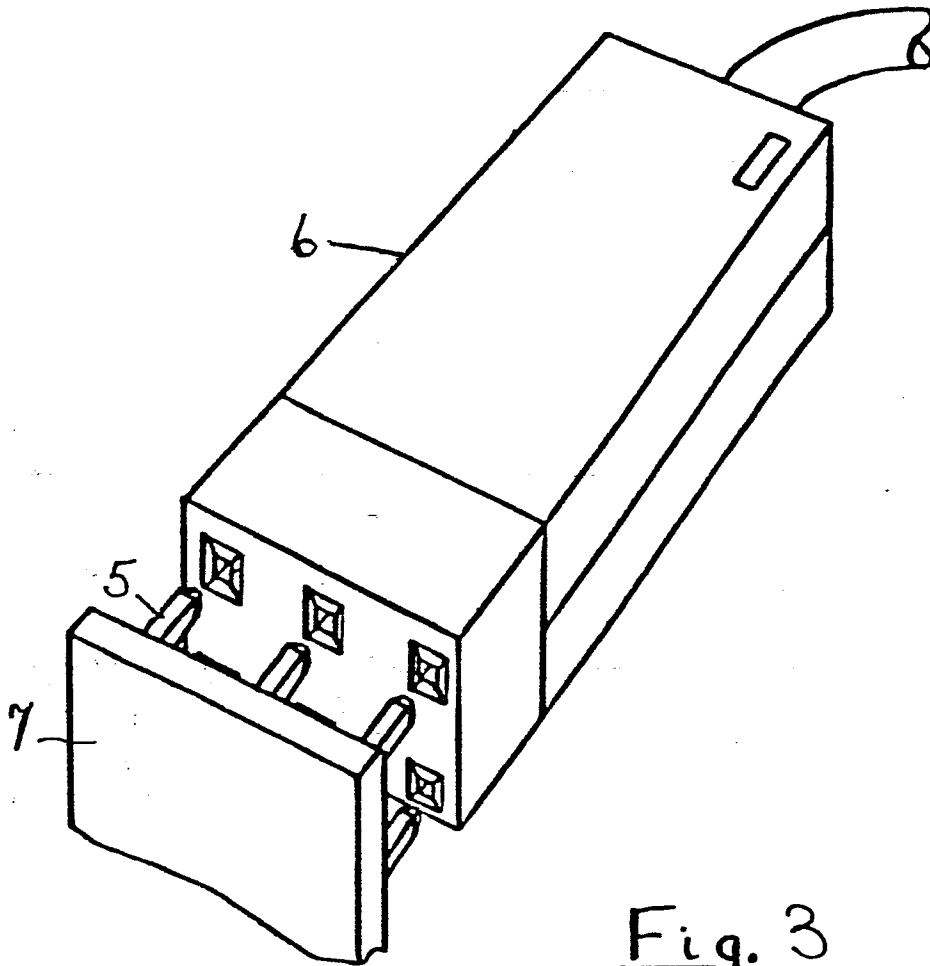

Fig. 3