



US006466344B2

(12) **United States Patent**
Shimomura et al.

(10) **Patent No.:** **US 6,466,344 B2**
(45) **Date of Patent:** **Oct. 15, 2002**

(54) **OPTICAL SWITCH, OPTICAL AMPLIFIER AND OPTICAL POWER CONTROLLER AS WELL AS OPTICAL ADD-DROP MULTIPLEXER**

(75) Inventors: **Hirofumi Shimomura; Seigo Takahashi; Naoya Henmi**, all of Tokyo (JP)

(73) Assignee: **NEC Corporation**, Tokyo (JP)

(*) Notice: Subject to any disclaimer, the term of this patent is extended or adjusted under 35 U.S.C. 154(b) by 0 days.

(21) Appl. No.: **09/939,665**

(22) Filed: **Aug. 28, 2001**

(65) **Prior Publication Data**

US 2002/0003644 A1 Jan. 10, 2002

Related U.S. Application Data

(62) Division of application No. 09/181,620, filed on Oct. 28, 1998.

(30) **Foreign Application Priority Data**

Oct. 28, 1997 (JP) 09-311070
Oct. 28, 1997 (JP) 09-311071
Oct. 30, 1997 (JP) 09-298427

(51) **Int. Cl.**⁷ **H04J 14/02**

(52) **U.S. Cl.** **359/128; 359/134; 359/127; 359/174; 359/176; 359/177; 359/179; 359/341; 359/337; 359/130; 359/160**

(58) **Field of Search** 359/134, 127, 359/128, 174, 176, 177, 179, 341, 337, 130, 160

(56) **References Cited**

U.S. PATENT DOCUMENTS

5,241,414 A * 8/1993 Giles et al. 359/341

5,570,218 A * 10/1996 Sotom 359/117
5,812,307 A * 9/1998 Naganuma 359/341
5,812,710 A * 9/1998 Sugaya 385/27
5,815,613 A * 9/1998 Fatehi et al. 385/22
5,914,799 A * 6/1999 Tan 359/167
6,016,219 A * 1/2000 Fatehi et al. 359/341
6,069,731 A * 5/2000 Bayart 359/341
6,297,902 B1 * 10/2001 Kosaka et al. 359/337
6,344,914 B1 * 2/2002 Shimojoh et al. 359/177

FOREIGN PATENT DOCUMENTS

JP 59135441 8/1984
JP 22768 1/1990

(List continued on next page.)

Primary Examiner—Leslie Pascal

Assistant Examiner—Hanh Phan

(74) *Attorney, Agent, or Firm*—Young & Thompson

(57) **ABSTRACT**

The first present invention provides an optical switch including the following elements. At least a plurality of optical transmission lines are provided for transmission of optical signals. Each of the at least plurality of optical transmission lines have at least an impurity doped fiber. At least an excitation light source is provided for emitting an excitation light. At least an excitation light switch is provided which is connected to the excitation light source and also connected to the at least plurality of optical transmission lines for individual switching operations to supply the excitation light to the at least plurality of optical transmission lines to feed the excitation light to the impurity doped fiber on the at least plurality of optical transmission lines, thereby causing an excitation of the impurity doped fiber on selected one of the at least plurality of optical transmission lines so as to permit a transmission of the optical signal through the excited impurity doped fiber, whilst unselected one of the impurity doped fibers is unexcited whereby the optical signals are absorbed into the unselected one of the impurity doped fibers thereby to discontinue transmission of the optical signal by the unselected one of the impurity doped fibers.

9 Claims, 20 Drawing Sheets

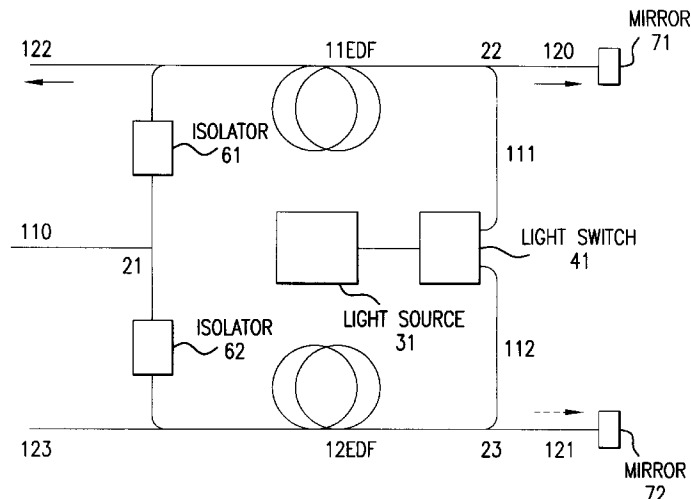

FOREIGN PATENT DOCUMENTS					
			JP	6324368	11/1994
			JP	7226560	8/1995
JP	2291531	12/1990	JP	7245436	9/1995
JP	37917	1/1991	JP	936834	2/1997
JP	3207139	9/1991	JP	996785	4/1997
JP	3235922	10/1991	JP	998135	4/1997
JP	49929	1/1992	JP	9258148	10/1997
JP	4251828	9/1992	JP	1146029	2/1999
JP	4260381	9/1992	JP	1146030	2/1999
JP	4362834	12/1992	JP	1155700	2/1999
JP	529686	2/1993	JP	1198087	4/1999
JP	541697	2/1993			
JP	651252	2/1994			

* cited by examiner

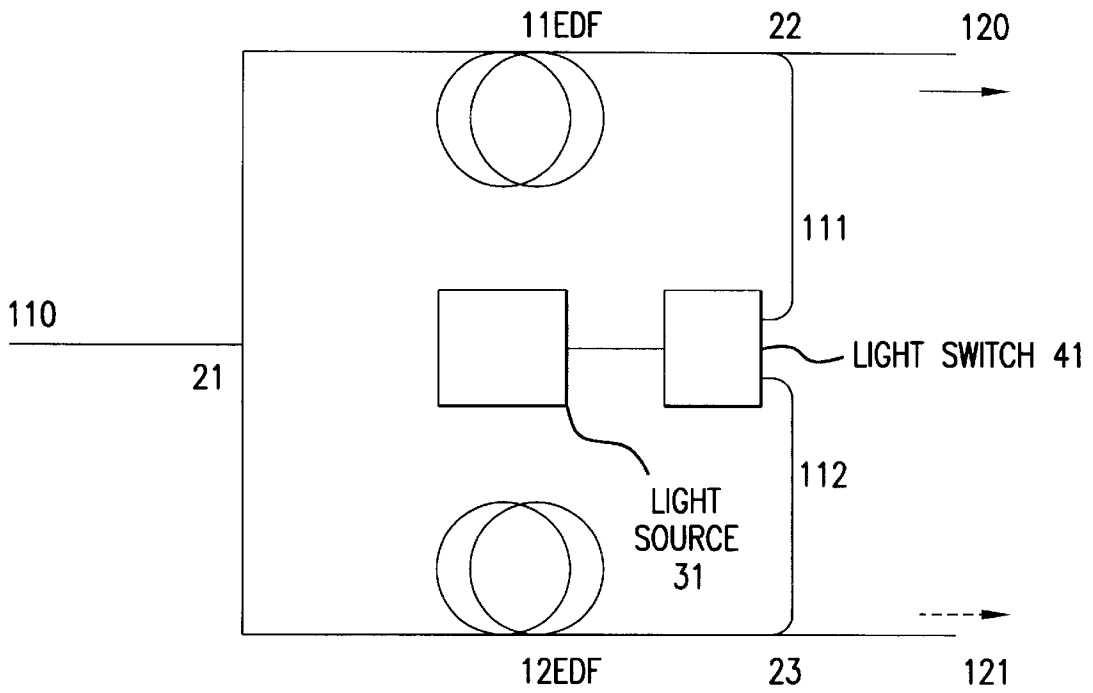

FIG. 1

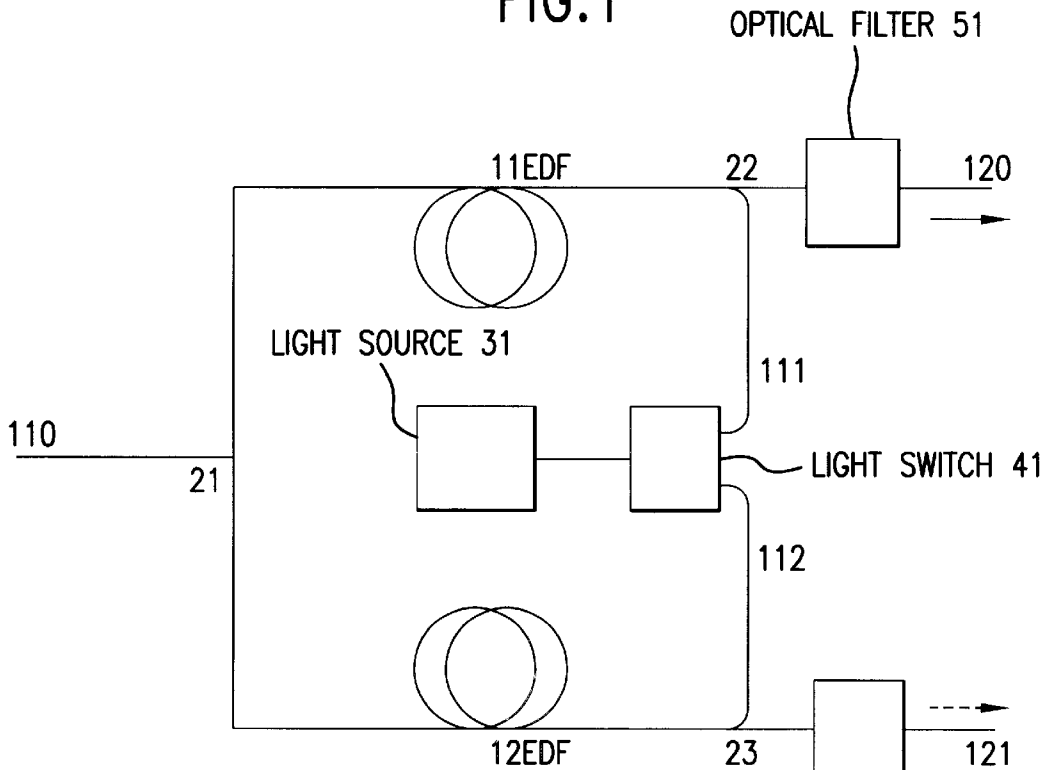

FIG. 2

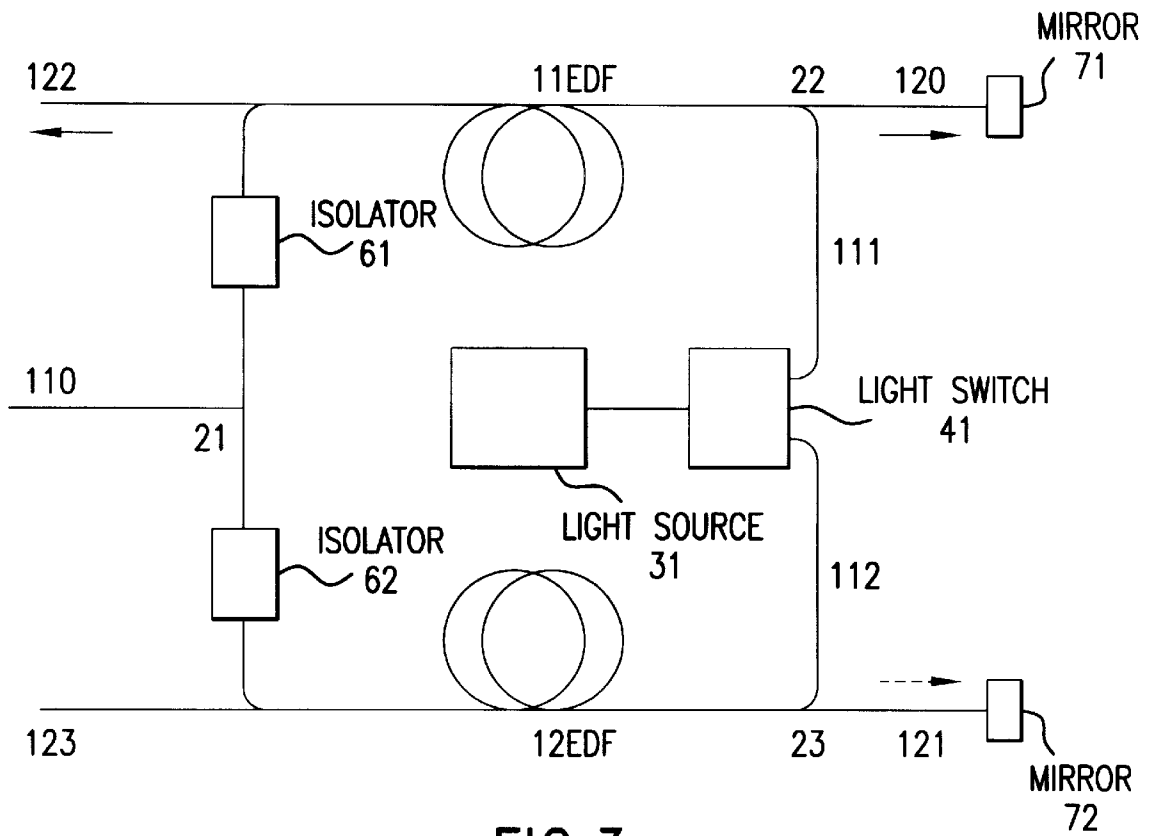

FIG.3

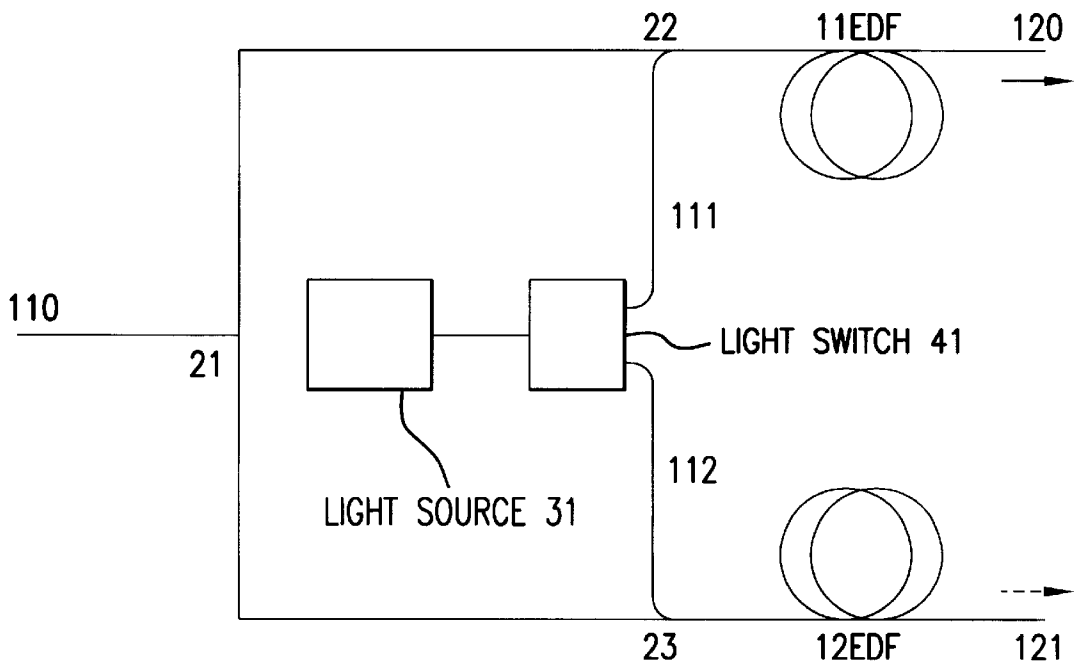

FIG.4

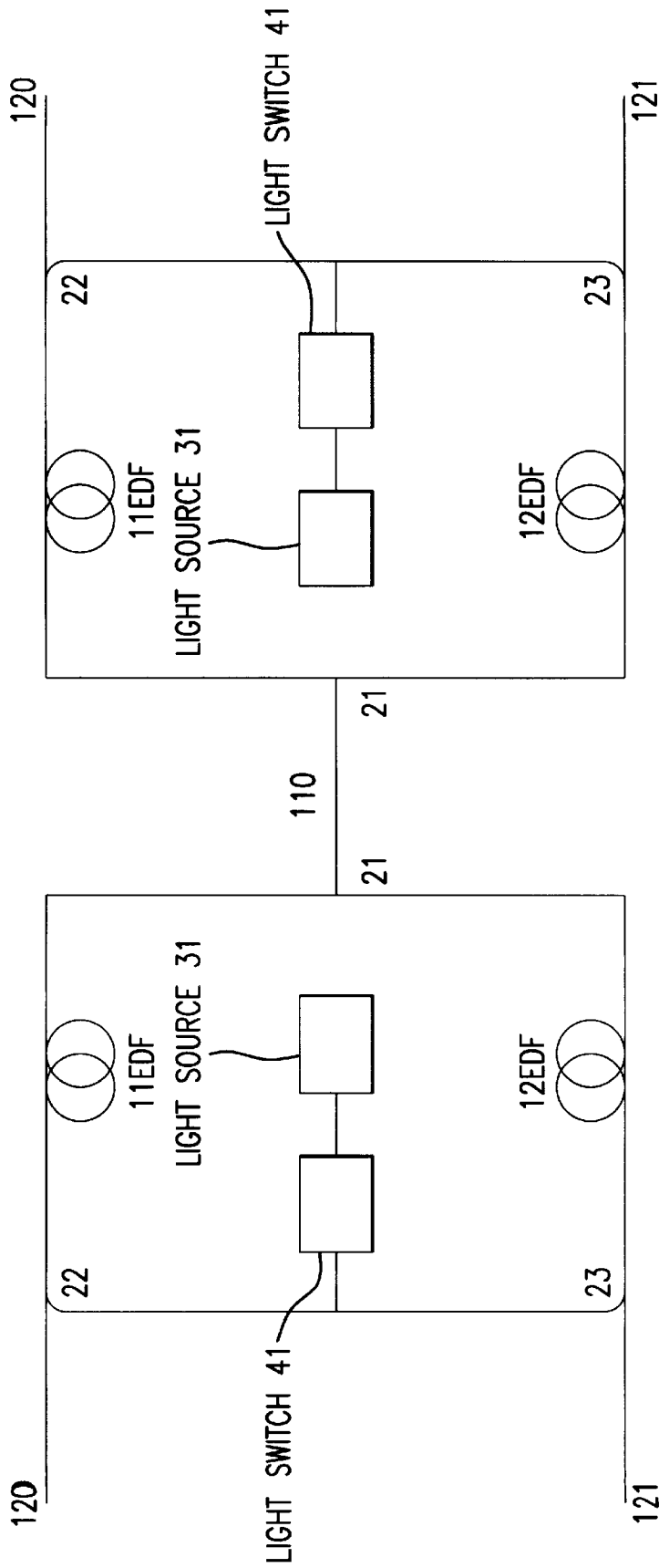

FIG. 5

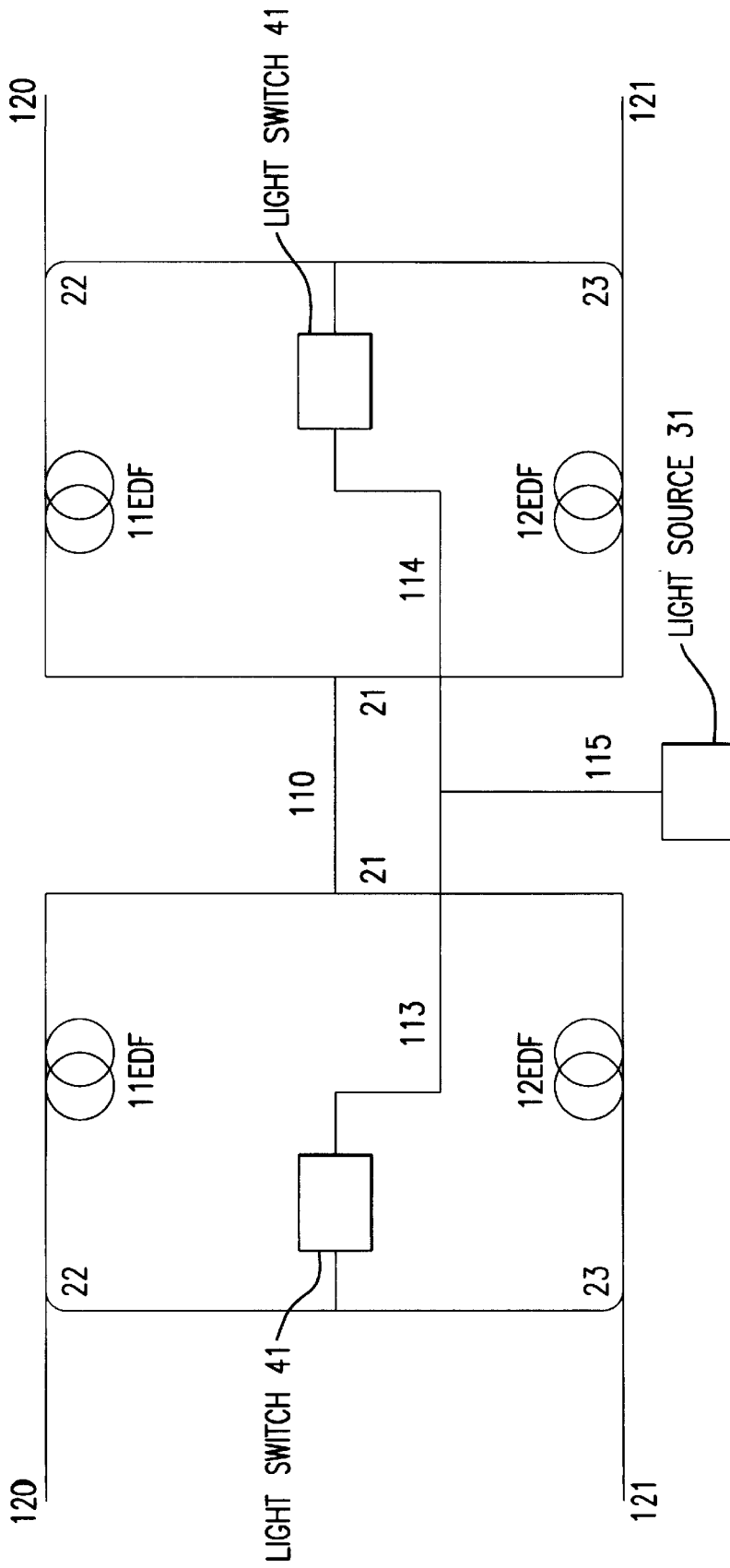

FIG.6

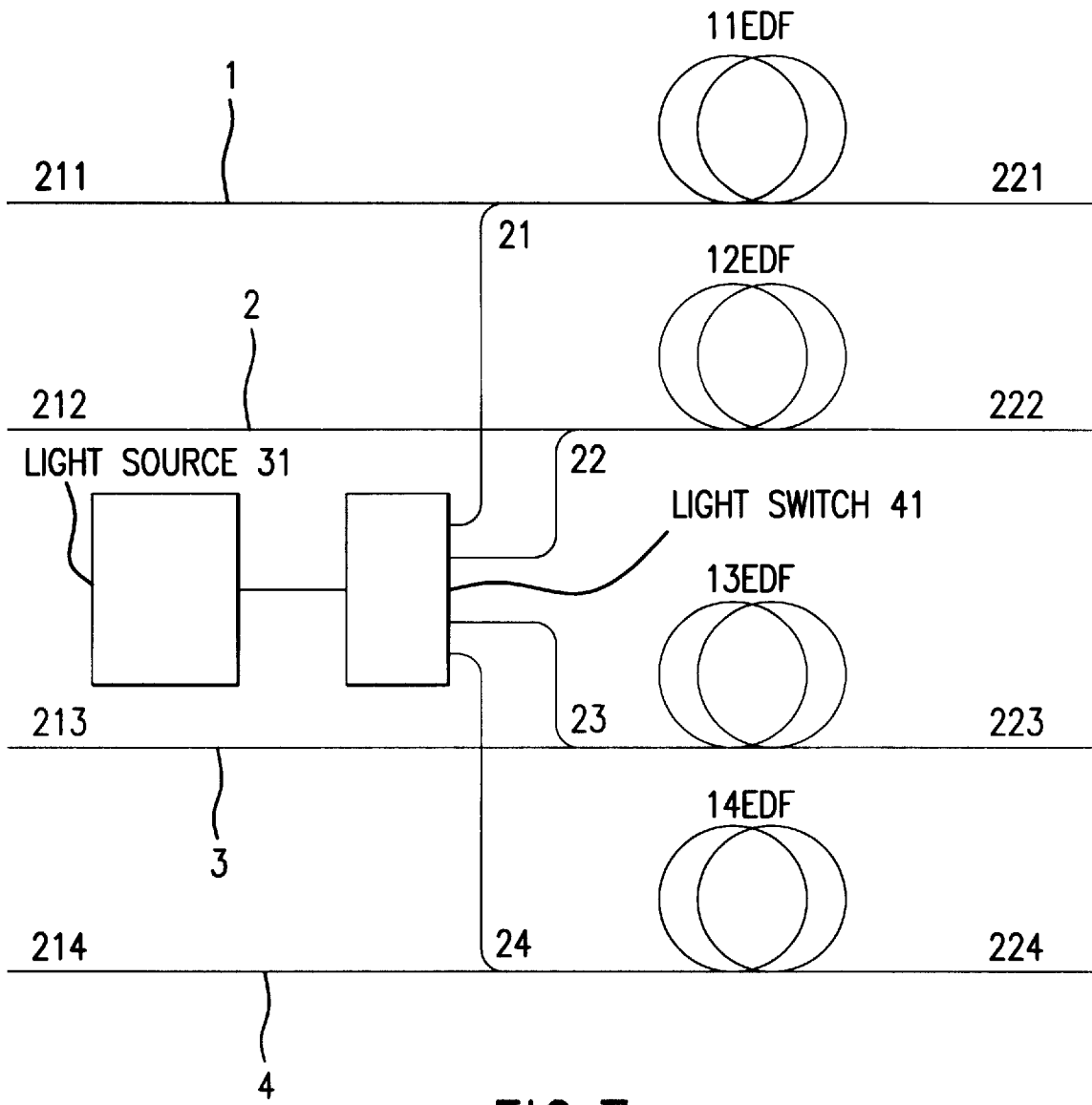

FIG.7

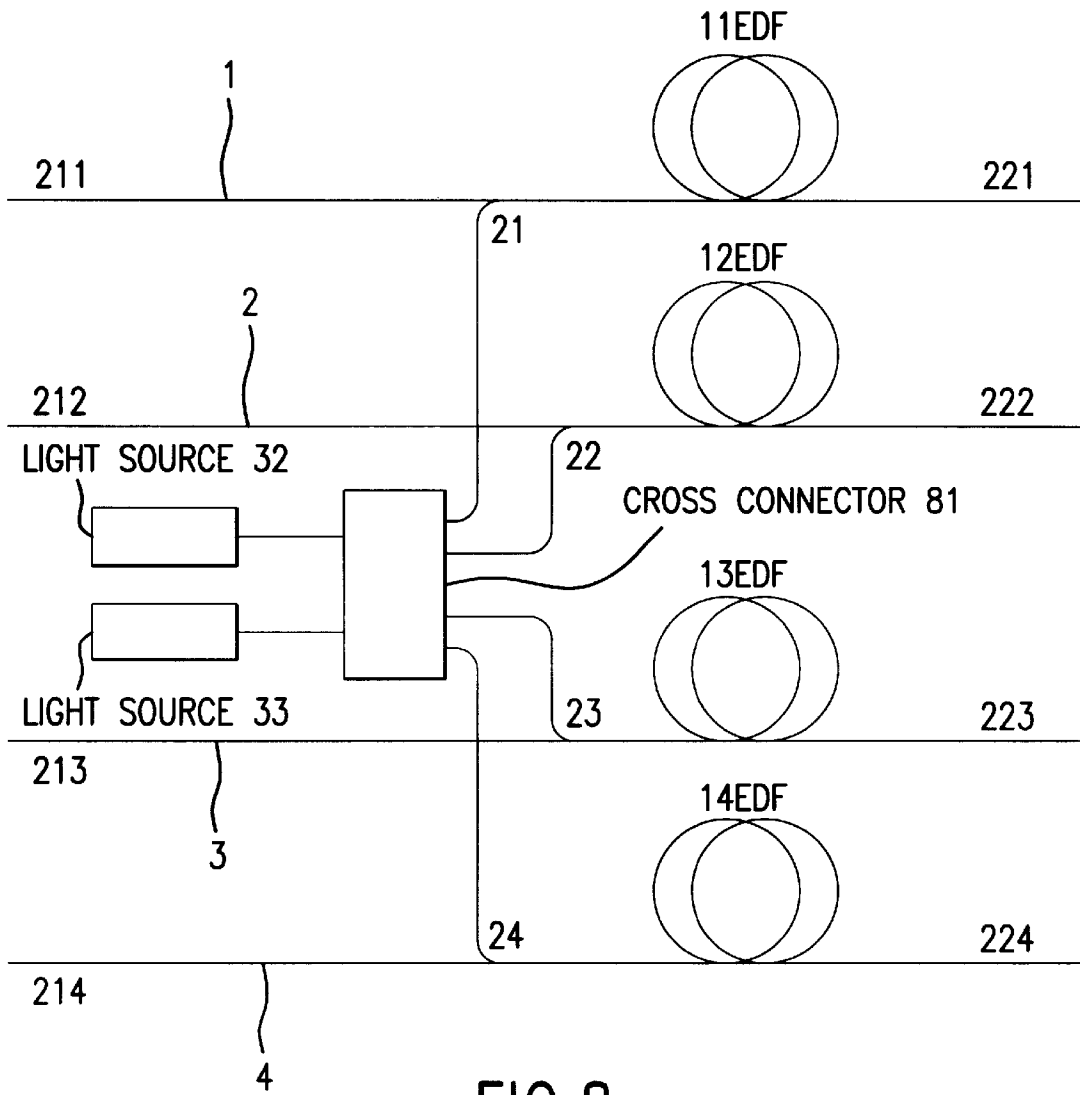

FIG.8

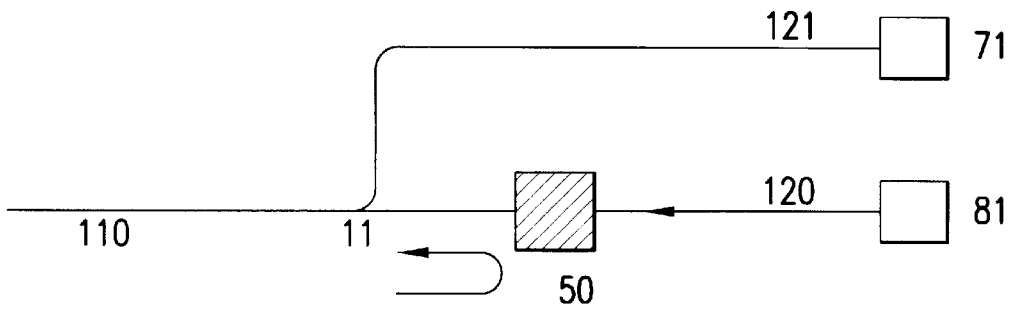

FIG.9

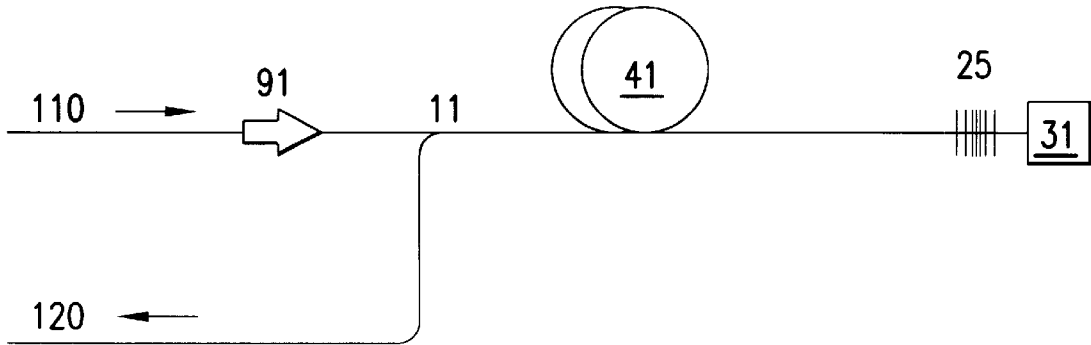

FIG.10

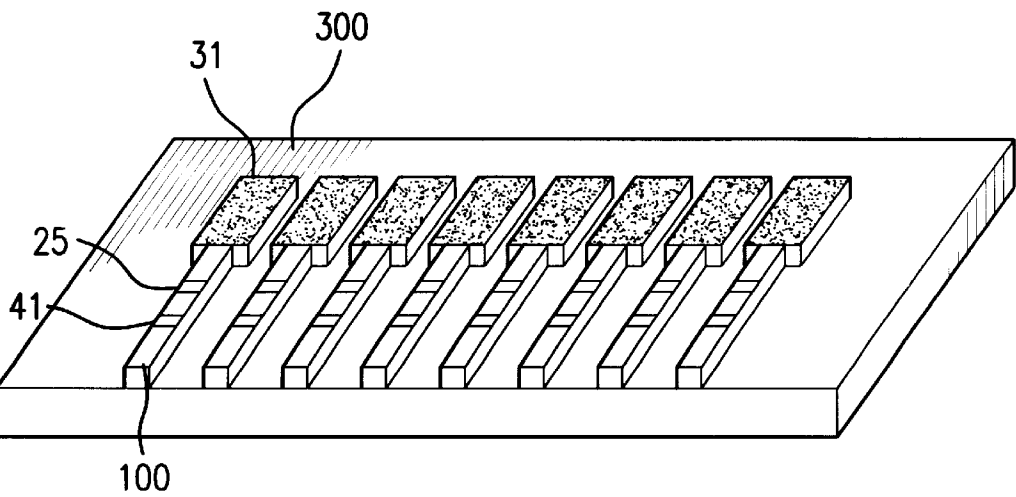

FIG.11

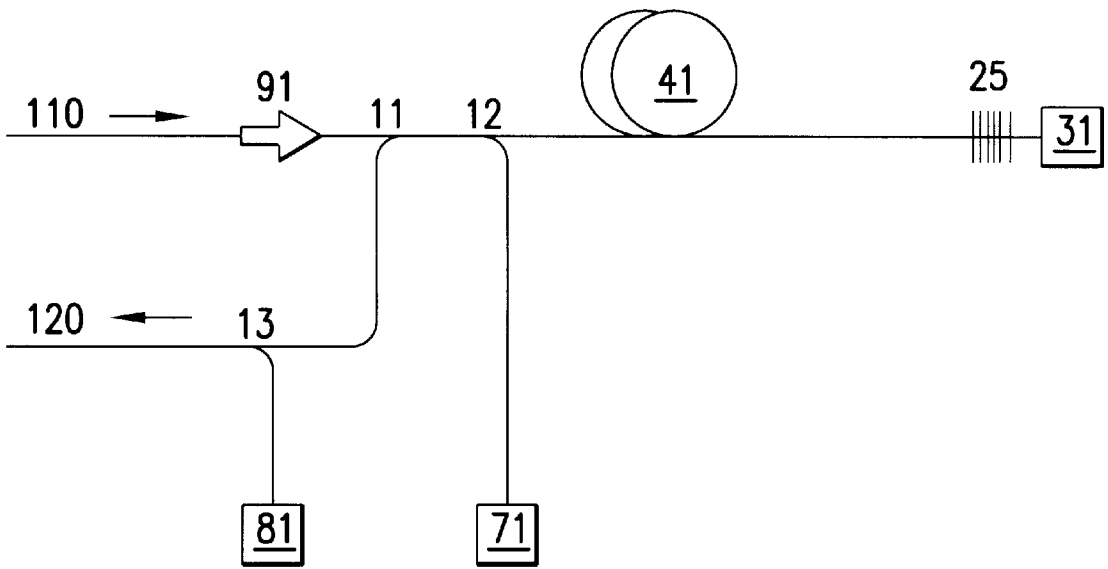

FIG.12

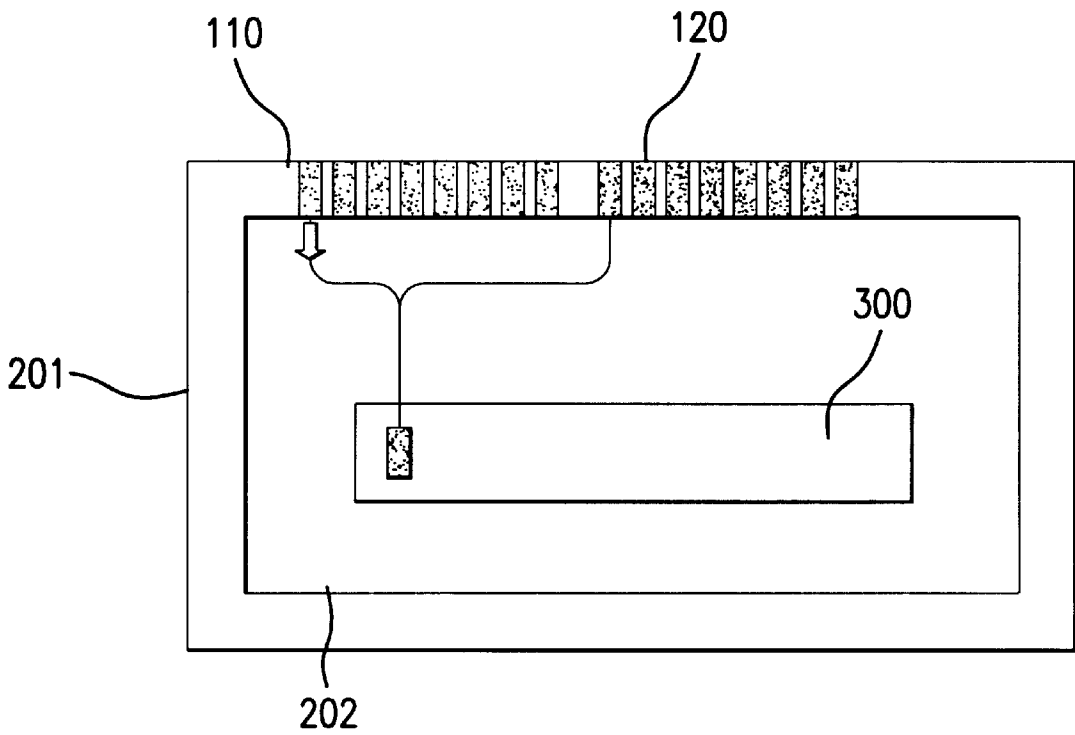

FIG.13

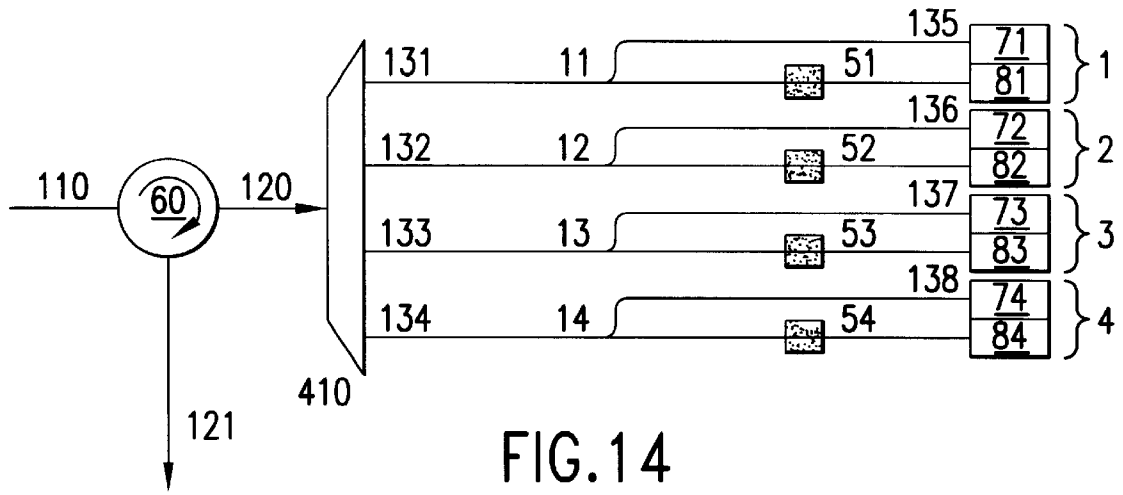

FIG. 14

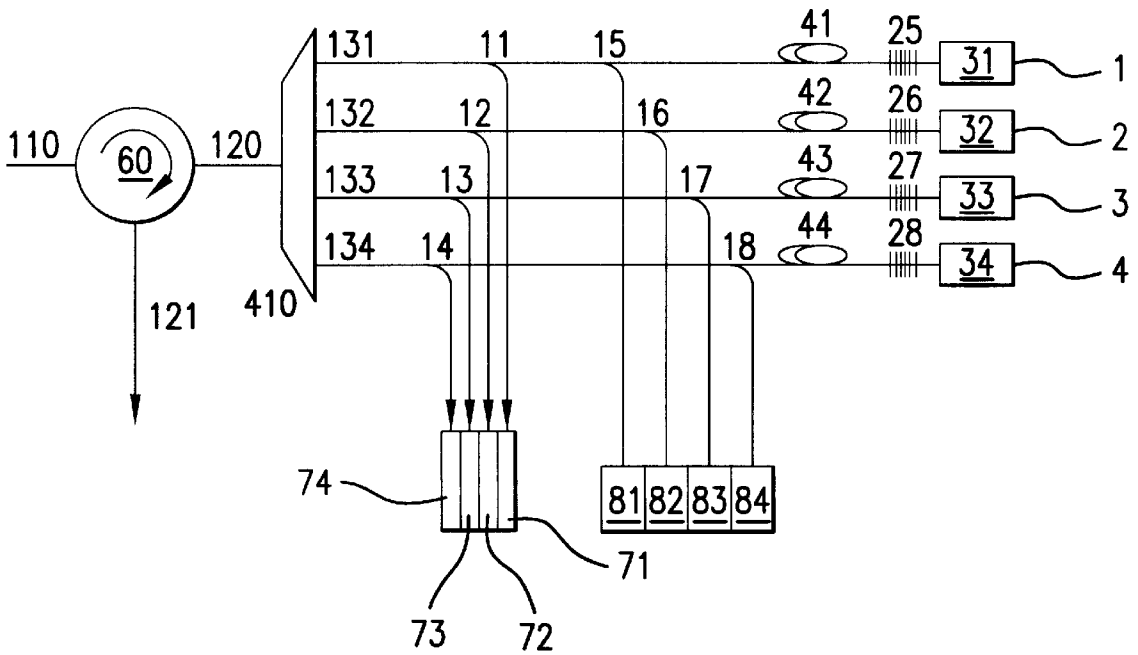

FIG. 15

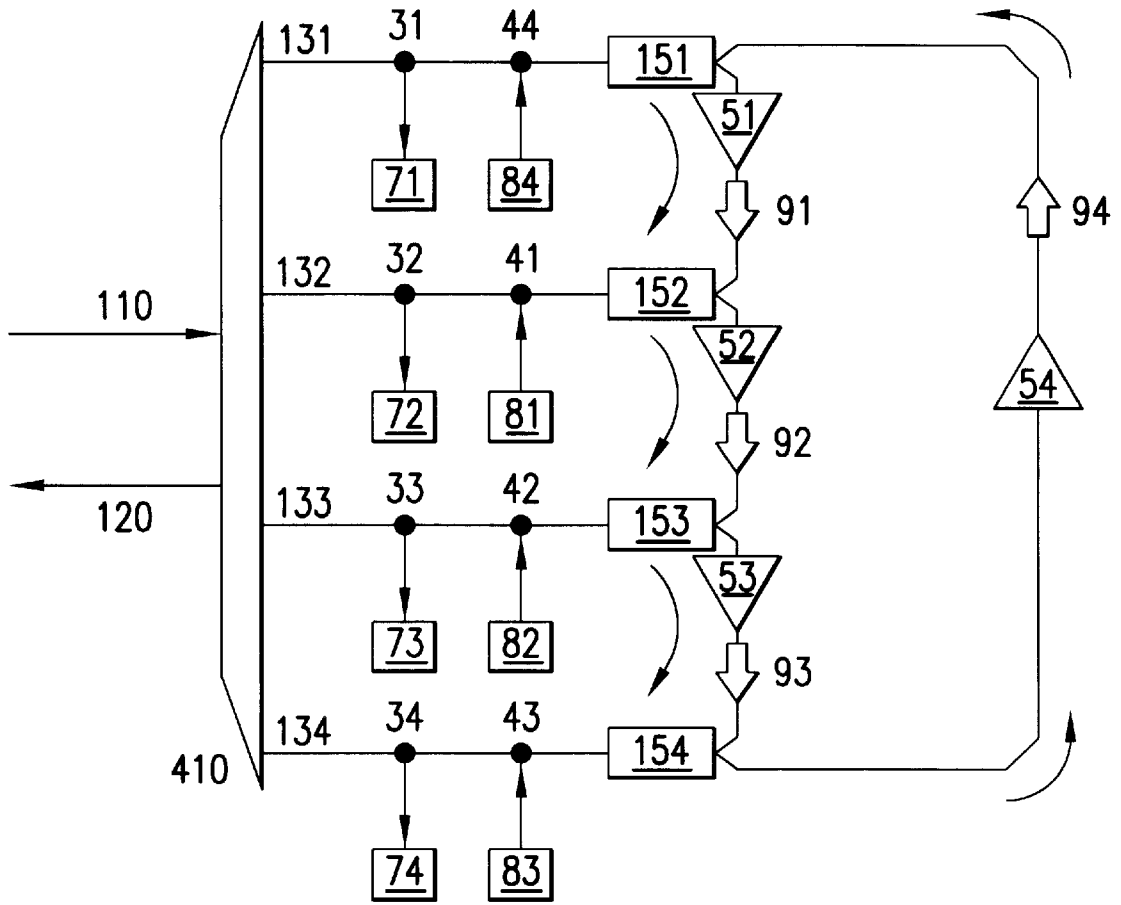

FIG.16

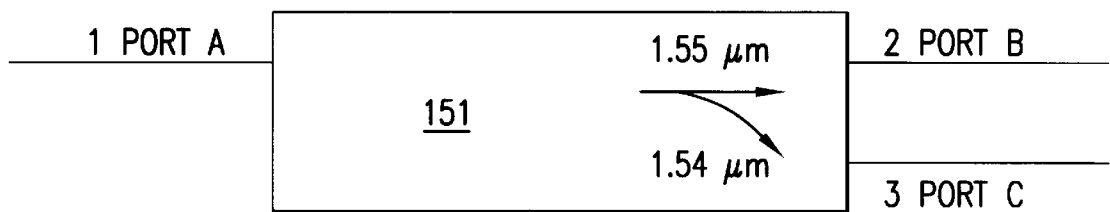

FIG.17

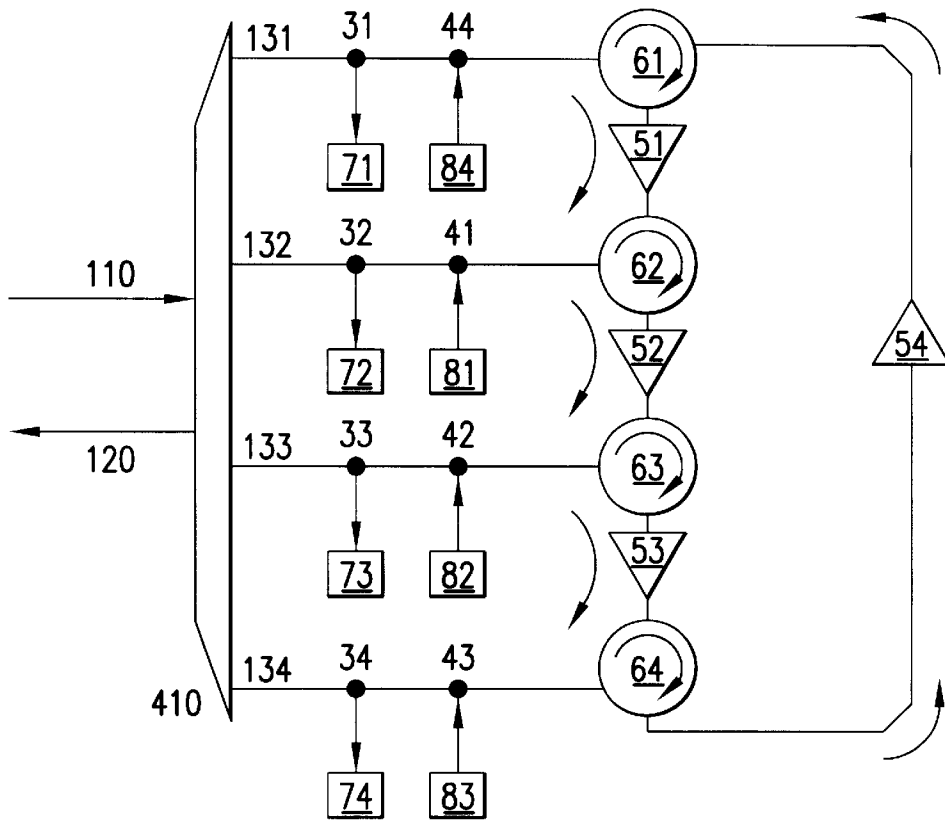

FIG. 18

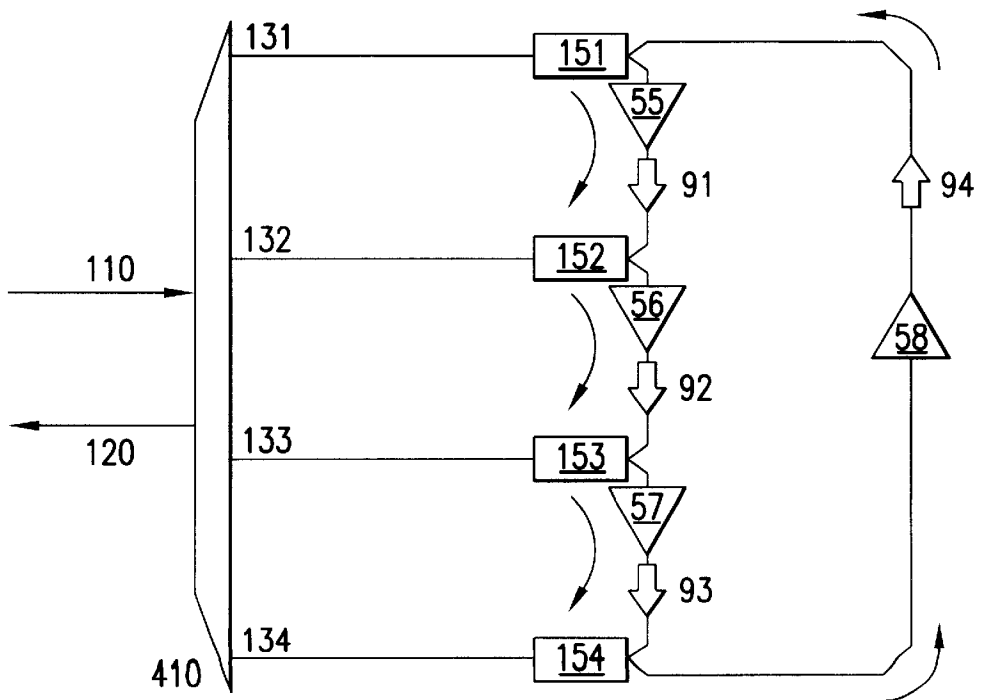

FIG. 19

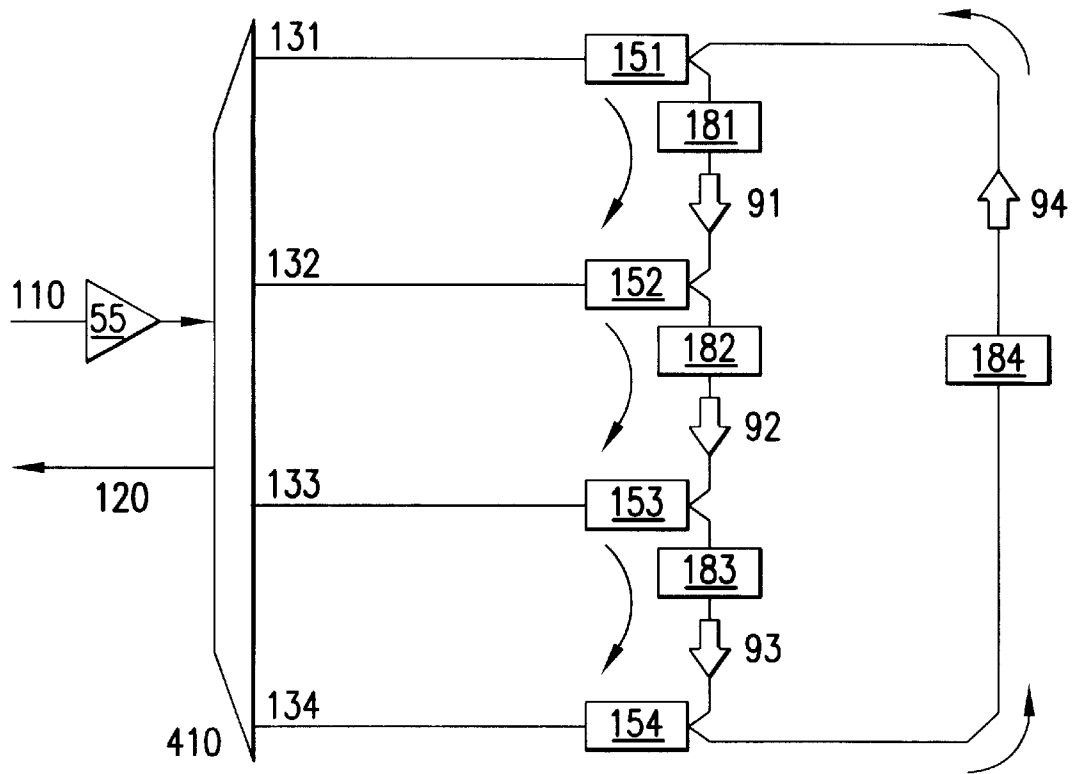

FIG.20

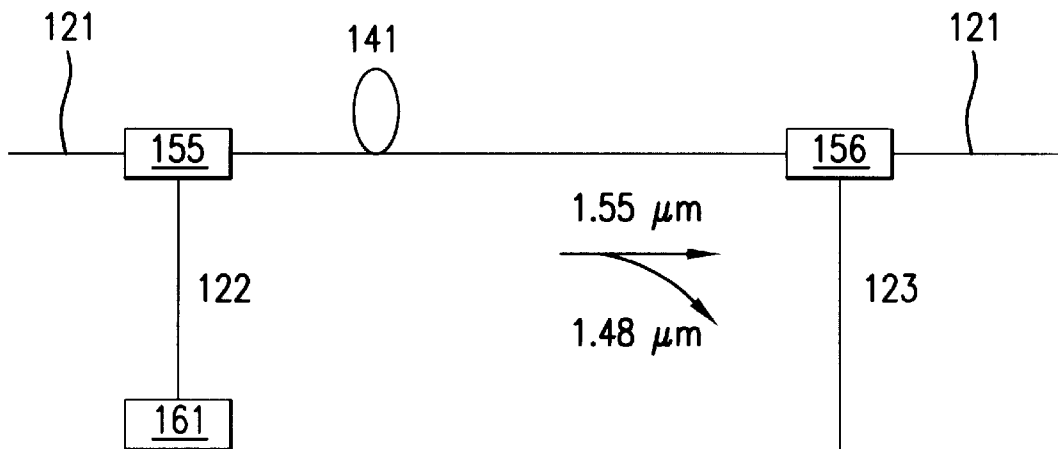

FIG.21

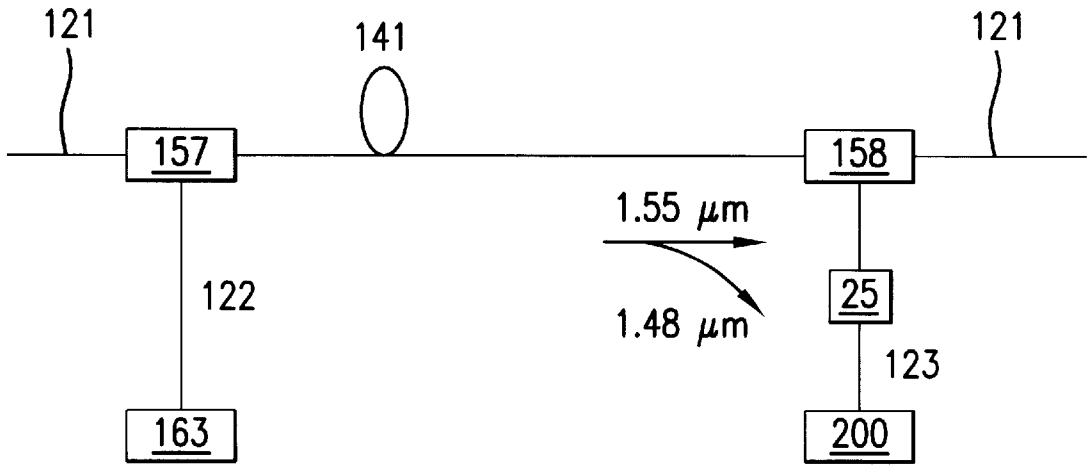

FIG.22

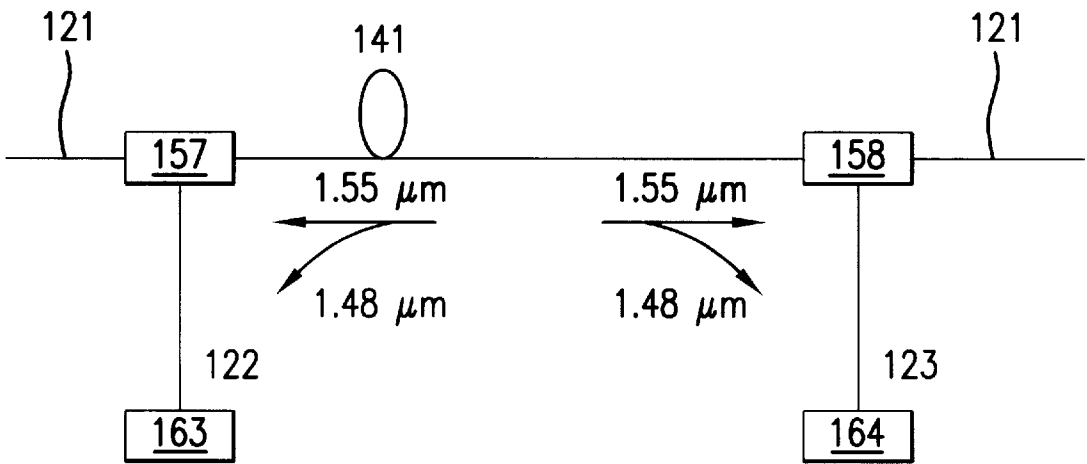

FIG.23

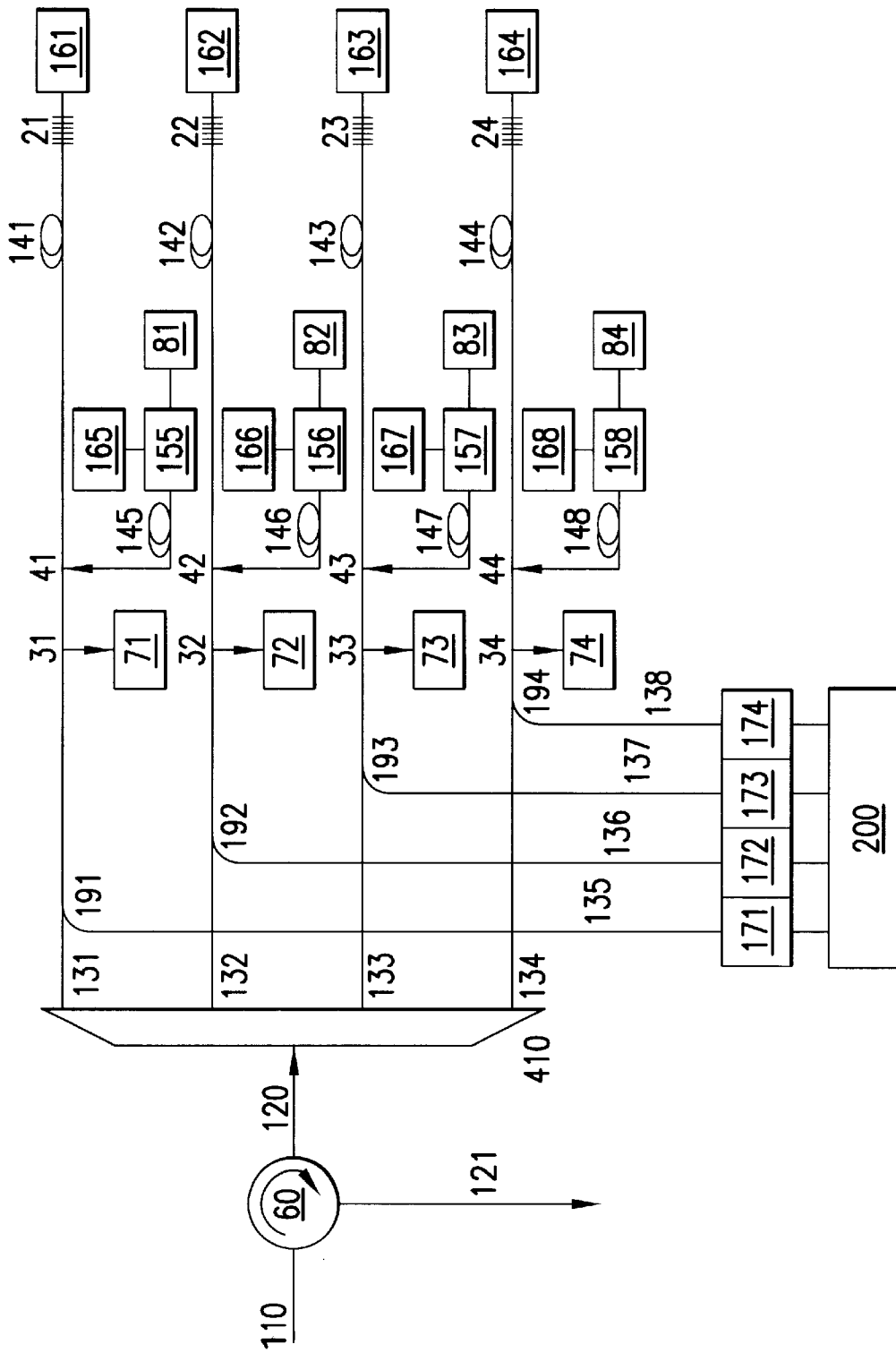

FIG.25

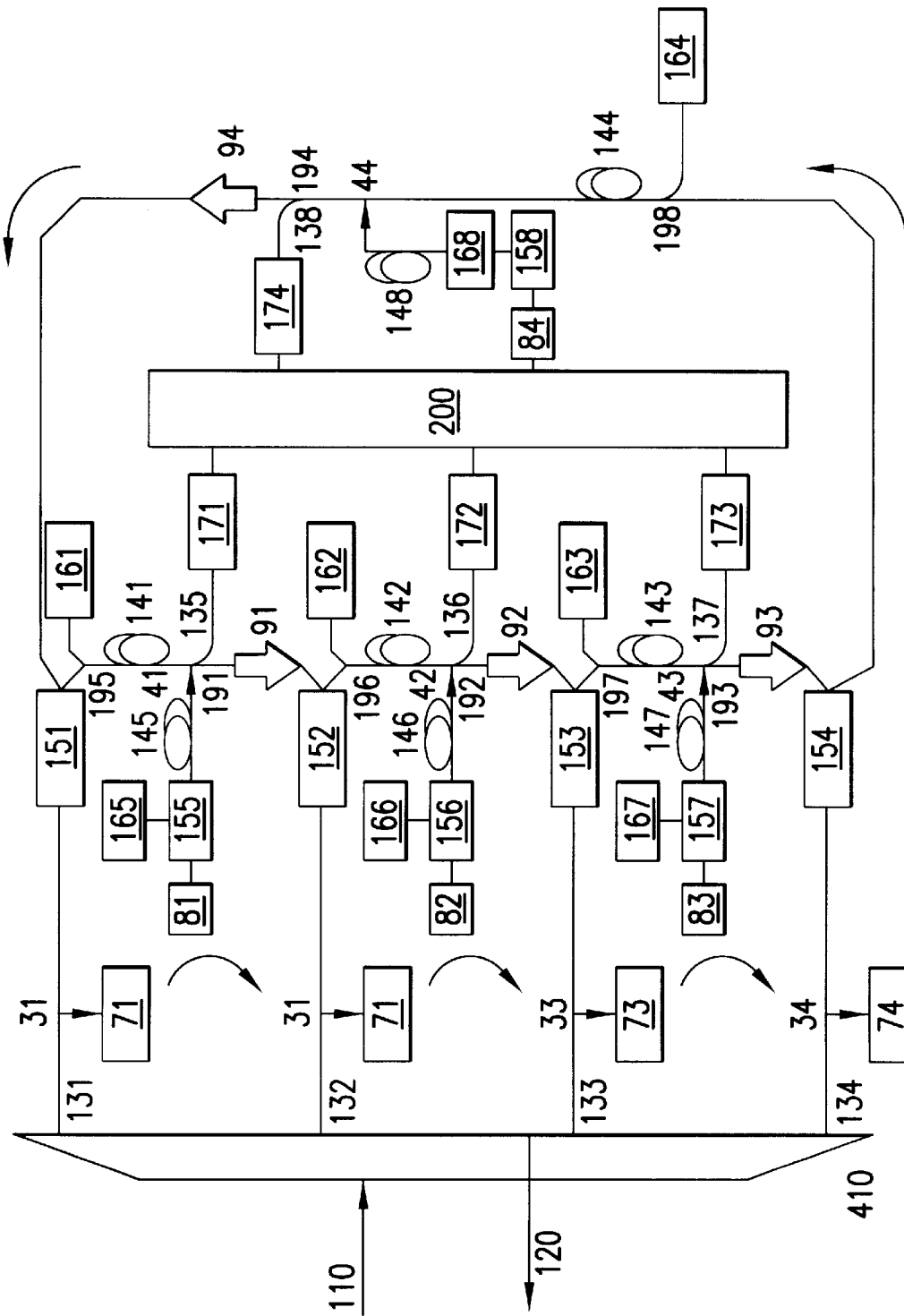

FIG. 26

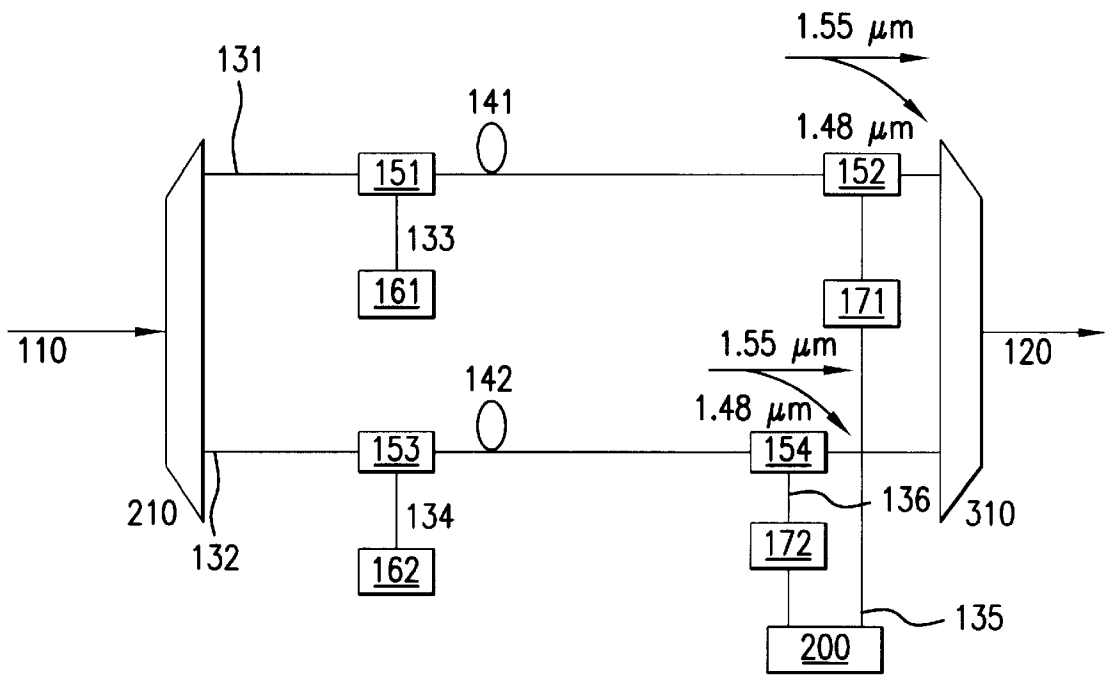

FIG.27

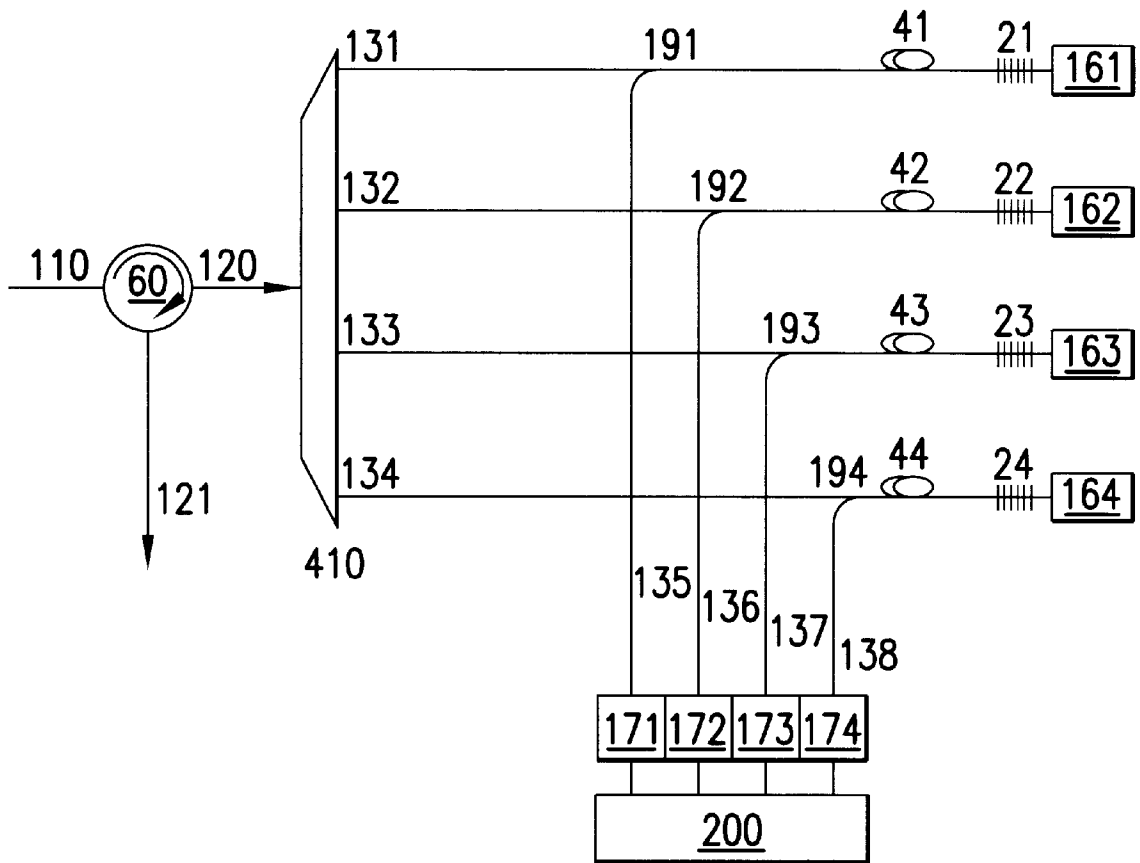

FIG.28

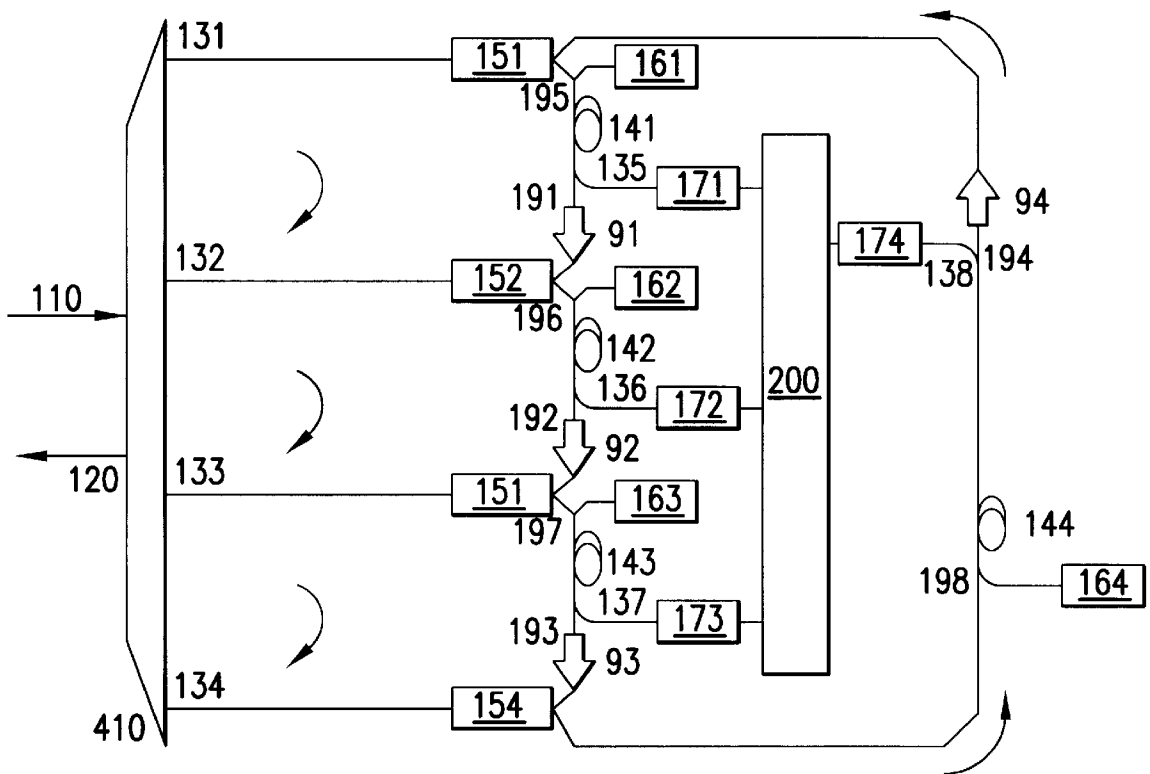

FIG.29

1

**OPTICAL SWITCH, OPTICAL AMPLIFIER
AND OPTICAL POWER CONTROLLER AS
WELL AS OPTICAL ADD-DROP
MULTIPLEXER**

This application is a division of co-pending application Ser. No. 09/181,620, filed on Oct. 28, 1998, the entire contents of which are hereby incorporated by reference.

BACKGROUND OF THE INVENTION

The present invention relates to an optical switch, an optical amplifier and an optical power controller as well as an optical add-drop multiplexer.

SUMMARY OF THE INVENTION

Accordingly, it is an object of the present invention to provide a novel optical switch free from the above problems.

It is a further object of the present invention to provide a novel optical amplifier.

It is a still further object of the present invention to provide a novel optical power controller.

It is yet a further object of the present invention to provide a novel optical add-drop multiplexer.

The first present invention provides an optical switch including the following elements. At least a plurality of optical transmission lines are provided for transmissions of optical signals. Each of the at least plurality of optical transmission lines have at least an impurity doped fiber. At least an excitation light source is provided for emitting an excitation light. At least an excitation light switch is provided which is connected to the excitation light source and also connected to the at least plurality of optical transmission lines for individual switching operations to supply the excitation light to the at least plurality of optical transmission lines to feed the excitation light to the impurity doped fiber on the at least plurality of optical transmission lines, thereby causing an excitation of the impurity doped fiber on selected one of the at least plurality of optical transmission lines so as to permit a transmission of the optical signal through the excited impurity doped fiber, whilst unselected one of the impurity doped fibers is unexcited whereby the optical signals are absorbed into the unselected one of the impurity doped fibers thereby to discontinue transmission of the optical signal by the unselected one of the impurity doped fibers.

The above and other objects, features and advantages of the present invention will be apparent from the following descriptions.

BRIEF DESCRIPTION OF THE DRAWINGS

Preferred embodiments according to the present invention will be described in detail with reference to the accompanying drawings.

FIG. 1 is a diagram illustrative of a first novel optical switch having a single input and two outputs in a first embodiment in accordance with the present invention.

FIG. 2 is a diagram illustrative of a second novel optical switch having a single input and two outputs in a second embodiment in accordance with the present invention.

FIG. 3 is a diagram illustrative of a third novel optical switch having a single input and two outputs in a third embodiment in accordance with the present invention.

FIG. 4 is a diagram illustrative of a fourth novel optical switch having a single input and two outputs in a fourth embodiment in accordance with the present invention.

2

FIG. 5 is a diagram illustrative of a fifth novel optical switch having two inputs and two outputs in a fifth embodiment in accordance with the present invention.

FIG. 6 is a diagram illustrative of a sixth novel optical switch having two inputs and two outputs in a sixth embodiment in accordance with the present invention.

FIG. 7 is a diagram illustrative of a seventh novel optical switch having four separate optical transmission lines for separately switching optical signal transmissions on the four separate optical transmission lines in a seventh embodiment in accordance with the present invention.

FIG. 8 is a diagram illustrative of an eighth novel optical switch having four separate optical transmission lines for separately switching optical signal transmissions on the four separate optical transmission lines in an eighth embodiment in accordance with the present invention.

FIG. 9 is a diagram illustrative of a ninth novel optical switch provided in a novel first optical add-drop multiplexer performing optical addition, drop and transmission of said optical signals in a ninth embodiment in accordance with the present invention.

FIG. 10 is a diagram illustrative of a tenth novel optical switch as an optical gate switch in a tenth embodiment in accordance with the present invention.

FIG. 11 is a schematic view illustrative of an integration of the above novel optical gate switch in a tenth embodiment in accordance with the present invention.

FIG. 12 is a diagram illustrative of a novel optical add-drop multiplexer using an optical gate switch of FIG. 10 for performing optical addition, drop and transmission of said optical signals in an eleventh embodiment in accordance with the present invention.

FIG. 13 is a schematic view illustrative of an integration of the above novel optical add-drop multiplexer in an eleventh embodiment in accordance with the present invention.

FIG. 14 is a diagram illustrative of a novel wavelength-multiplexed optical add-drop multiplexer using four sets of the above novel optical add-drop multiplexer of FIG. 9 in a twelfth embodiment in accordance with the present invention.

FIG. 15 is a diagram illustrative of a novel wavelength-multiplexed optical add-drop multiplexer using four sets of the above novel optical add-drop multiplexer of FIG. 12 in a thirteenth embodiment in accordance with the present invention.

FIG. 16 is a diagram illustrative of a novel wavelength-multiplexed optical add-drop multiplexer having four looped optical transmission paths in a fourteenth embodiment in accordance with the present invention.

FIG. 17 is a diagram illustrative of the first optical multiplexer/demultiplexer used in the wavelength-multiplexed optical add-drop multiplexer of FIG. 16 in a fourteenth embodiment in accordance with the present invention.

FIG. 18 is a diagram illustrative of a novel wavelength-multiplexed optical add-drop multiplexer having four looped optical transmission paths in a fifteenth embodiment in accordance with the present invention.

FIG. 19 is a diagram illustrative of a novel wavelength-multiplexed optical amplifier having four looped optical transmission paths in a sixteenth embodiment in accordance with the present invention.

FIG. 20 is a diagram illustrative of a novel wavelength-multiplexed optical add-drop multiplexer having four

looped optical transmission paths in a seventeenth embodiment in accordance with the present invention.

FIG. 21 is a diagram illustrative of a novel optical gate switch utilizing optical wavelength multiplexer/demultiplexer and an erbium doped fiber in an eighteenth embodiment in accordance with the present invention.

FIG. 22 is a diagram illustrative of a novel optical gate switch utilizing optical wavelength multiplexer/demultiplexer and an erbium doped fiber in a nineteenth embodiment in accordance with the present invention.

FIG. 23 is a diagram illustrative of novel optical gate switch utilizing optical wavelength multiplexer/demultiplexer and an erbium doped fiber in a twenty embodiment in accordance with the present invention.

FIG. 24 is a novel wavelength-multiplexed optical add-drop multiplexer utilizing optical multiplexer/demultiplexers in place of optical couplers and further utilizing erbium doped fibers in a twenty first embodiment in accordance with the present invention.

FIG. 25 is a novel wavelength-multiplexed optical add-drop multiplexer which is modified from the above novel wavelength-multiplexed optical add-drop multiplexer of FIG. 15 by utilizing optical multiplexer/demultiplexers in place of optical couplers and further utilizing erbium doped fibers in a twenty second embodiment in accordance with the present invention.

FIG. 26 is a novel wavelength-multiplexed optical add-drop multiplexer which is modified from the above novel wavelength-multiplexed optical add-drop multiplexer of FIG. 16 by utilizing optical multiplexer/demultiplexers in place of optical couplers and further utilizing erbium doped fibers in a twenty third embodiment in accordance with the present invention.

FIG. 27 is a novel wavelength-multiplexed optical add-drop multiplexer utilizing optical multiplexer/demultiplexers in place of optical couplers and further utilizing erbium doped fibers in a twenty fourth embodiment in accordance with the present invention.

FIG. 28 is a novel wavelength-multiplexed optical add-drop multiplexer which is modified from the above novel wavelength-multiplexed optical add-drop multiplexer of FIG. 15 by utilizing optical multiplexer/demultiplexers in place of optical couplers and further utilizing erbium doped fibers in a twenty fifth embodiment in accordance with the present invention.

FIG. 29 is a novel wavelength-multiplexed optical add-drop multiplexer which is modified from the above novel wavelength-multiplexed optical add-drop multiplexer of FIG. 16 by utilizing optical multiplexer/demultiplexers in place of optical couplers and further utilizing erbium doped fibers in a twenty sixth embodiment in accordance with the present invention.

DISCLOSURE OF THE INVENTION

The first present invention provides an optical switch including the following elements. At least a plurality of optical transmission lines are provided for transmissions of optical signals. Each of the at least plurality of optical transmission lines have at least an impurity doped fiber. At least an excitation light source is provided for emitting an excitation light. At least an excitation light switch is provided which is connected to the excitation light source and also connected to the at least plurality of optical transmission light for individual switching operations to supply the excitation light to the at least plurality of optical transmis-

sion lines to feed the excitation light to the impurity doped fiber on the at least plurality of optical transmission lines, thereby causing an excitation of the impurity doped fiber on selected one of the at least plurality of optical transmission lines so as to permit a transmission of the optical signal through the excited impurity doped fiber, whilst unselected one of the impurity doped fibers is unexcited whereby the optical signals are absorbed into the unselected one of the impurity doped fibers thereby to discontinue transmission of the optical signal by the unselected one of the impurity doped fibers.

It is preferable that the optical switch further includes: a single input side optical transmission line; and a single input optical coupler connected to the single input side optical transmission line, and wherein the at least plurality of optical transmission lines comprise first and second optical transmission lines which are connected through the single input side optical coupler to the single input side optical transmission line, and the first and second optical transmission lines have first and second impurity doped fibers, and wherein the at least excitation light source comprises a single excitation light source, and the at least excitation light switch comprises a single excitation light switch which has first and second output terminals for selecting any one of the first and second output terminals, and the first output terminal is connected through a first optical coupler to the first impurity doped fiber to feed the excitation light to the first impurity doped fiber only when the first output terminal is selected by the single excitation light switch, and the second output terminal is connected through a second optical coupler to the second impurity doped fiber to feed the excitation light to the second impurity doped fiber only when the second output terminal is selected by the single excitation light switch.

It is preferable further comprise first and second optical filters. The first optical filter is provided on the first optical transmission line and positioned between the first optical coupler and an output terminal of the first optical transmission line so as to remove a noise from the first optical signal when the first impurity doped fiber is excited. The second optical filter is provided on the second optical transmission line and positioned between the second optical coupler and an output terminal of the second optical transmission line so as to remove a noise from the second optical signal when the second impurity doped fiber is excited.

It is preferable further comprise the following elements. A first optical reflective mirror is provided on one end of the first optical transmission line for reflecting the first optical signal passed through the first impurity doped fiber excited so that the reflected first optical signal is again transmitted through the first impurity doped fiber excited to an opposite end as an output terminal of the first optical transmission line. A first optical isolator is provided between the input side optical coupler and the first optical transmission line for permitting a unidirectional transmission of an optical signal from the input side optical coupler to the first optical transmission line. A second optical reflective mirror is provided on one end of the second optical transmission line for reflecting the second optical signal passed through the second impurity doped fiber excited so that the reflected second optical signal is again transmitted through the second impurity doped fiber excited to an opposite end as an output terminal of the second optical transmission line. A second optical isolator is provided between the input side optical coupler and the second optical transmission line for permitting a unidirectional transmission of an optical signal from the input side optical coupler to the second optical transmission line.

5

It is preferable further comprise the following elements. A first optical reflective mirror is provided on one end of the first optical transmission line for reflecting the first optical signal passed through the first impurity doped fiber excited so that the reflected first optical signal is again transmitted through the first impurity doped fiber excited to an opposite end as an output terminal of the first optical transmission line. A second optical reflective mirror is provided on one end of the second optical transmission line for reflecting the second optical signal passed through the second impurity doped fiber excited so that the reflected second optical signal is again transmitted through the second impurity doped fiber excited to an opposite end as an output terminal of the second optical transmission line. A circulator is provided as the input side optical coupler and an optical isolator provided between the input side optical transmission line and the first and second optical transmission lines.

It is preferable that the first optical coupler is inserted between the first impurity doped fiber and an output terminal of the first optical transmission line so as to feed the excitation light to the first impurity doped fiber in an opposite direction to a transmission of the first optical signal through the first impurity doped fiber excited, and also the second optical coupler is inserted between the second impurity doped fiber and an output terminal of the second optical transmission line so as to feed the excitation light to the second impurity doped fiber in an opposite direction to a transmission of the second optical signal through the second impurity doped fiber excited.

It is preferable that the first optical coupler is inserted between the first impurity doped fiber and the input side optical coupler so as to feed the excitation light to the first impurity doped fiber in the same direction as transmission of the first optical signal through the first impurity doped fiber excited, and also the second optical coupler is inserted between the second impurity doped fiber and the input side optical coupler so as to feed the excitation light to the second impurity doped fiber in the same direction as a transmission of the second optical signal through the second impurity doped fiber excited.

It is preferable that the optical switch has two inputs and two outputs and comprises a pair of first and second optical switches connected to each other through at least an interconnecting optical transmission line, and wherein each of the first and second optical switches further comprises the following elements. A single input side optical coupler is provided which is connected to the single input side optical transmission line. First and second optical transmission lines are connected through the single input side optical coupler to the single input side optical transmission line. The first and second optical transmission lines have first and second impurity doped fibers. A single excitation light source is provided. A single excitation light switch is provided which has first and second output terminals for selecting any one of the first and second output terminals. The first output terminal is connected through a first optical coupler to the first impurity doped fiber to feed the excitation light to the first impurity doped fiber only when the first output terminal is selected by the single excitation light switch. The second output terminal is connected through a second optical coupler to the second impurity doped fiber to feed the excitation light to the second impurity doped fiber only when the second output terminal is selected by the single excitation light switch.

It is preferable that each of the first and second optical switches further comprises first and second optical filters. The first optical filter is provided on the first optical trans-

6

mission line and positioned between the first optical coupler and an output terminal of the first optical transmission line so as to remove a noise from the first optical signal when the first impurity doped fiber is excited. The second optical filter is provided on the second optical transmission line and positioned between the second optical coupler and an output terminal of the second optical transmission line so as to remove a noise from the second optical signal when the second impurity doped fiber is excited.

It is preferable that each of the first and second optical switches further comprises the following elements. A first optical reflective mirror is provided on one end of the first optical transmission line for reflecting the first optical signal passed through the first impurity doped fiber excited so that the reflected first optical signal is again transmitted through the first impurity doped fiber excited to an opposite end as an output terminal of the first optical transmission line. A first optical isolator is provided between the input side optical coupler and the first optical transmission line for permitting a unidirectional transmission of an optical signal from the input side optical coupler to the first optical transmission line. A second optical reflective mirror is provided on one end of the second optical transmission line for reflecting the second optical signal passed through the second impurity doped fiber excited so that the reflected second optical signal is again transmitted through the second impurity doped fiber excited to an opposite end as an output terminal of the second optical transmission line. A second optical isolator is provided between the input side optical coupler and the second optical transmission line for permitting a unidirectional transmission of an optical signal from the input side optical coupler to the second optical transmission line.

It is preferable that each of the first and second optical switches further comprises the following elements. A first optical reflective mirror is provided on one end of the first optical transmission line for reflecting the first optical signal passed through the first impurity doped fiber excited so that the reflected first optical signal is again transmitted through the first impurity doped fiber excited to an opposite end as an output terminal of the first optical transmission line. A second optical reflective mirror is provided on one end of the second optical transmission line for reflecting the second optical signal passed through the second impurity doped fiber excited so that the reflected second optical signal is again transmitted through the second impurity doped fiber excited to an opposite end as an output terminal of the second optical transmission line. A circulator is provided as the input side optical coupler and an optical isolator provided between the input side optical transmission line and the first and second optical transmission lines.

It is preferable that, for each of the first and second optical switches, the first optical coupler is inserted between the first impurity doped filter and an output terminal of the first optical transmission line so as to feed the excitation light to the first impurity doped fiber in an opposite direction to a transmission of the first optical signal through the first impurity doped fiber excited, and also the second optical coupler is inserted between the second impurity doped fiber and an output terminal of the second optical transmission line so as to feed the excitation light to the second impurity doped fiber in an opposite direction to a transmission of the second optical signal through the second impurity doped fiber excited.

It is preferable that, for each of the first and second optical switches, the first optical coupler is inserted between the first impurity doped fiber and the input side optical coupler so as

to feed the excitation light to the first impurity doped fiber in the same direction as a transmission of the first optical signal through the first impurity doped fiber excited, and also the second optical coupler is inserted between the second impurity doped fiber and the input side optical coupler so as to feed the excitation light to the second impurity doped fiber in the same direction as a transmission of the second optical signal through the second impurity doped fiber excited.

It is preferable that the optical switch has two inputs and two outputs and comprises a pair of first and second optical switches connected to each other through at least an interconnecting optical transmission line, and a common excitation light source connected to the first and second optical switches, and wherein each of the first and second optical switches further comprises the following elements. A single input side optical coupler is provided which is connected to the single input side optical transmission line. First and second optical transmission lines are provided which are connected through the single input side optical coupler to the single input side optical transmission line. The first and second optical transmission lines have first and second impurity doped fibers. A single excitation light switch is provided which is connected to the common excitation light source, the single excitation light switch having first and second output terminals for selecting any one of the first and second output terminals, and the first output terminal being connected through a first optical coupler to the first impurity doped fiber to feed the excitation light to the first impurity doped fiber only when the first output terminal is selected by the single excitation light switch, and the second output terminal being connected through a second optical coupler to the second impurity doped fiber to feed the excitation light to the second impurity doped fiber only when the second output terminal is selected by the single excitation light switch.

It is preferable that the at least plurality of optical transmission lines are separated from each other for separate transmissions of different optical signals on the plurality of separated optical transmission lines. Each of the separated optical transmission lines has a single impurity doped fiber. The at least excitation light source comprises a single excitation light source. The at least excitation light switch comprises a single excitation light switch for separate switching operations to the at least plurality of optical transmission lines to a separately control individual excitations of the impurity doped fibers on the at least plurality of optical transmission lines.

It is preferable that the at least plurality of optical transmission lines are separated from each other for separate transmissions of different optical signals on the plurality of separated optical transmission lines, and each of the separated-optical transmission lines has a single impurity doped fiber, and the at least excitation light source comprises two excitation light source, and further the at least excitation light switch comprises a single optical cross connector for separate switching operations to the at least plurality of optical transmission lines to separately control individual excitations of the impurity doped fibers on the at least plurality of optical transmission lines.

The second present invention provides an optical switch comprising the following elements. A first optical transmission line is provided for transmitting a first optical signal. An optical reflectivity variable mirror is provided which is capable of varying a reflectivity in a range of 0% to 100% for reflecting the first optical signal. The optical reflectivity variable mirror is connected with the first optical transmission line. A second optical transmission line is provided

which is connected through the optical reflectivity variable mirror to the first optical transmission line. An optical transmitter is provided which is connected through the second optical transmission line to the optical reflectivity variable mirror for transmitting a second optical signal. If the optical reflectivity variable mirror sets the reflectivity at less than 100%, then the first optical signal is reflected by the optical reflectivity variable mirror so that the first optical signal is outputted from the first optical transmission line, if the optical reflectivity variable mirror sets the reflectivity at 100%, then the first optical signal is transmitted through the optical reflectivity variable mirror, whilst the second optical signal transmitted from the optical transmitter is also transmitted through the optical reflectivity variable mirror to be outputted from the first optical transmission line.

The third present invention provides an optical add-drop multiplexer comprising at least a single set of the following elements. A first optical transmission line is provided for transmitting a first optical signal. An optical coupler is provided on the first optical transmission line for dividing the first optical signal into first and second divided optical signals. A fourth optical transmission line is provided which is connected with the optical coupler for transmitting the first divided optical signal. An optical receiver is provided which is connected through the fourth optical transmission line to the optical coupler for receiving the first divided optical signal. An optical reflectivity variable mirror is provided which is capable of varying a reflectivity in a range of 0% to 100%. The optical reflectivity variable mirror is connected with the first optical transmission line for reflecting the second divided optical signal. A second optical transmission line is provided which is connected through the optical reflectivity variable mirror to the first optical transmission line. An optical transmitter is provided which is connected through the second optical transmission line to the optical reflectivity variable mirror for transmitting a second optical signal. If the optical reflectivity variable mirror sets the reflectivity at less than 100%, then the first optical signal is reflected by the optical reflectivity variable mirror so that the first optical signal is outputted from the first optical transmission line. If the optical reflectivity variable mirror sets the reflectivity at 100%, then the first optical signal is transmitted through the optical reflectivity variable mirror, whilst the second optical signal transmitted from the optical transmitter is also transmitted through the optical reflectivity variable mirror to be outputted from the first optical transmission line.

It is preferable that the optical add-drop multiplexer comprises a plurality of the optical add-drop multiplexers, and further comprising an optical device having at least any one of multiplexing function and demultiplexing function so that the optical add-drop multiplexers are operable to different wavelength optical signals.

The fourth present invention provides an optical add-drop multiplexer comprising at least a single set of the following elements. An input side optical transmission line is provided for transmitting a first optical signal. An input side optical coupler is provided on the first optical transmission line for dividing the first optical signal into first and second divided optical signals. First and second optical transmission lines are provided which are connected with the input side optical coupler for transmissions of the first and second divided optical signals respectively. The first and second optical transmission lines have first and second impurity doped fibers. An optical receiver is provided which is connected through the first optical transmission line to the first impurity doped fiber for receiving the first divided optical signal only

when the first impurity doped fiber is excited. An optical transmitter is provided which is connected through the second optical transmission line to the second impurity doped fiber for transmitting a second optical signal through the second impurity doped fiber to the input side optical transmission line for output of the second optical signal only when the second impurity doped fiber is excited. At least an excitation light source is provided for emitting an excitation light. An excitation light switch is provided which is connected to the excitation light source and also connected to the first and second optical transmission lines for selective switching operations to supply the excitation light to any one of the first and second optical transmission lines to feed the excitation light to selected one of the first and second impurity doped fibers, thereby causing an excitation of the selected one of the first and second impurity doped-fibers, whilst unselected one of the first and second impurity doped fibers is unexcited.

It is preferable that the optical add-drop multiplexer comprises a plurality of the optical add-drop multiplexers, and further comprising an optical device having at least one of multiplexing function and demultiplexing function so that the optical add-drop multiplexers are operable to different wavelength optical signals.

The fifth present invention provides an optical gate switch comprising the following elements. A first optional transmission line is provided for transmitting an input optical input signal. A second optical transmission line is provided for transmitting an optical output signal. A fourth optional transmission line is connected through an optical coupler to both the first and second optical transmission lines. The fourth optical transmission line has at least a impurity doped fiber and a wavelength band selective optical reflecting mirror capable of selecting a wavelength band of a light to be reflected. The impurity doped fiber is positioned between the wavelength band selective optical reflecting mirror. An excitation light source is provided which is connected to the wavelength band selective optical reflecting mirror for controlling an emission of an excitation light so that if the excitation light source emits the excitation light to feed the excitation light to the impurity doped fiber so as to excite the impurity doped fiber, whereby the optical input signal is transmitted through the excited impurity doped fiber and amplified by the excited impurity doped fiber and subsequently the amplified optical signal is reflected by the wavelength band selective optical reflecting mirror before the reflected optical signal is then transmitted through the excited impurity doped fiber and further amplified by the excited impurity doped fiber for subsequent output of the further amplified optical signal through the output signal optical transmission line.

The sixth present invention provides an optical add-drop multiplexer comprising at least a single set of the following elements. A first optional transmission line is provided for transmitting an input optical input signal. A second optical transmission line is provided for transmitting an optical output signal. A fourth optional transmission line is provided which is connected through an optical coupler to both the first and second optional transmission lines. The fourth optional transmission line has at least a impurity doped fiber and a wavelength band selective optical reflecting mirror capable of selecting a wavelength band of a light to be reflected. The impurity doped fiber is positioned between the wavelength band selective optical reflecting mirror. An optical receiver is provided which is connected through a second optical coupler to the fourth optical transmission line so that the second optical coupler is positioned between the

first optical coupler and the impurity doped fiber for allowing the optical receiver receives a part of the optical input signal. An optical transmitter is provided which is connected through a fourth optical coupler to the output signal transmission line for transmitting a second optical signal as a substituted output original only when no output signal is supplied from the impurity doped fiber. An excitation light source is provided which is connected to the wavelength band selective optical reflecting mirror for controlling an emission of an excitation light so that if the excitation light source emits the excitation light to feed the excitation light to the impurity doped fiber so as to excite the impurity doped fiber, whereby the optical input signal is transmitted through the excited impurity doped fiber and amplified by the excited impurity doped fiber and subsequently the amplified optical signal is reflected by the wavelength band selective optical reflecting mirror before the reflected optical signal is then transmitted through the excited impurity doped fiber and further amplified by the excited impurity doped fiber for subsequent output of the further amplified optical signal through the output signal optical transmission line.

It is preferable that the optical add-drop multiplexer comprises a plurality of the optical add-drop multiplexers, and further comprising an optical device having at least any one of multiplexing function and demultiplexing function so that the optical add-drop multiplexers are operable to different wavelength optical signals.

The seventh present invention provides an optical transmission line junction structure comprising at least three optical transmission lines for transmuting optical signals and an optical device having at least any one of wavelength multiplexing and demultiplexing functions connected to the at least three optical transmission lines, so that the optical device having at least any one of multiplexing and demultiplexing functions serves as a same roll as an optical coupler so as to reduce an optical power loss when the optical signal is transmitted through the optical transmission line junction structure.

It is preferable that the optical device comprises an optical multiplexer/demultiplexer.

It is preferable that the optical device comprises an optical multiplexer.

It is preferable that the optical device comprises an optical demultiplexer.

The eighth present invention provides an optical transmission line junction structure comprising at least three optical transmission lines for transmitting optical signals and an optical circulator connected to the at least three optical transmission lines, so that the optical circulator serves as a same roll as an optical coupler so as to reduce an optical power loss when the optical signal is transmitted through the optical transmission line junction structure.

The ninth present invention provides an optical loop-structured circuit having at least a plurality of looped optical transmission lines having at least a plurality of optical transmission line junctions from which at least three optical transmission lines extend, wherein at least one of the plurality of optical transmission line junctions has an optical device having at least any one of wavelength multiplexing and demultiplexing functions, which is connected to the at least three optical transmission lines, so that the optical device having at least any one of multiplexing and demultiplexing functions serve as a same roll as an optical coupler so as to reduce an optical power loss when the optical signal is transmitted through the optical transmission line junction structure.

It is preferable that all of the plurality of optical transmission line junctions have the optical devices.

It is preferable that at least one of the plurality of looped optical transmission lines has at least a single set of an optical amplifier and an optical isolator so that the optical loop-structured circuit has a function of an optical amplifier.

It is preferable that the at least one of the plurality of looped optical transmission lines is further connected to at least two set of an optical receiver and an optical transmitter so that the optical loop-structured circuit has a function of an optical add-drop multiplexer.

It is preferable that at least one of the plurality of looped optical transmission lines has at least a single set of an optical attenuator and an optical isolator so that the optical loop-structured circuit has a function of an optical equalizer.

It is preferable that at least two of the plurality of looped optical transmission lines are connected to an optical multiplexer/demultiplexer, whilst a single looped optical transmission line is separated by the at least two of the plurality of looped optical transmission lines from the optical multiplexer/demultiplexer, so that optical signals are individually transmitted along the plurality of looped optical transmission lines, and wherein all of the plurality of optical transmission line junctions have the optical devices.

It is preferable that each of the plurality of looped optical transmission lines has at least a single set of an optical amplifier and an optical isolator so that the optical loop-structured circuit has a function of an optical amplifier.

It is preferable that each of the plurality of looped optical transmission lines is further connected to at least two set of an optical receiver and an optical transmitter so that the optical loop-structured circuit has a function of an optical add-drop multiplexer.

It is preferable that each of the plurality of looped optical transmission lines has at least a single set of an optical attenuator and an optical isolator so that the optical loop-structured circuit has a function of an optical equalizer.

It is preferable that the optical device comprises an optical multiplexer/demultiplexer.

It is preferable that the optical device comprises an optical multiplexer.

It is preferable that the optical device comprises an optical demultiplexer.

The tenth present invention provides an optical loop-structured circuit having at least a plurality of looped optical transmission lines having at least a plurality of optical transmission line junctions from which at least three optical transmission lines extend, wherein at least one of the plurality of optical transmission line junctions has an optical circulator, which is connected to the at least three optical transmission lines, so that the optical circulator serves as a same roll as an optical coupler so as to reduce an optical power loss when the optical signal is transmitted through the optical transmission line junction structure.

It is preferable that all of the plurality of optical transmission line junctions have the optical circulators.

It is preferable that at least one of the plurality of looped optical transmission lines has at least a single set of an optical amplifier and an optical isolator so that the optical loop-structured circuit has a function of an optical amplifier.

It is preferable that the at least one of the plurality of looped optical transmission lines is further connected to at least two set of an optical receiver and an optical transmitter so that the optical loop-structured circuit has a function of an optical add-drop multiplexer.

It is preferable that at least one of the plurality of looped optical transmission lines has at least a single set of an optical attenuator and an optical isolator so that the optical loop-structured circuit has a function of an optical equalizer.

It is preferable that at least two of the plurality of looped optical transmission lines are connected to an optical multiplexer/demultiplexer, whilst a single loop optical transmission line is separated by the at least two of the plurality of looped optical transmission lines from the optical multiplexer/demultiplexer, so that optical signals are individually transmitted along the plurality of looped optical transmission lines, and wherein all of the plurality of optical transmission line junctions have the optical circulators.

It is preferable that each of the plurality of looped optical transmission lines has at least a single set of an optical amplifier and an optical isolator so that the optical loop-structured circuit has a function of an optical amplifier.

It is preferable that each of the plurality of looped optical transmission lines is further connected to at least two set of an optical receiver and an optical transmitter so that the optical loop-structured circuit has a function of an optical add-drop multiplexer.

It is preferable that each of the plurality of looped optical transmission lines has at least a single set of an optical attenuator and an optical isolator so that the optical loop-structured circuit has a function of an optical equalizer.

The eleventh present invention provides an optical gate switch comprising the following elements. A main optical transmission line is provided. First and second optical multiplexer/demultiplexers are also provided on the main optical transmission line so that the first and second optical multiplexer/demultiplexer are separated from each other. The first and second optical multiplexer/demultiplexers are connected with first and second subordinate optical transmission lines respectively. An impurity doped fiber is provided on the main optical transmission line and positioned between the first and second optical multiplexer/demultiplexers. An excitation light source is provided which is connected through the first subordinate optical transmission line to the first optical multiplexer/demultiplexer so that the excitation light source emits an excitation light which is transmitted through the first subordinate optical transmission line and the first optical multiplexer/demultiplexer to the impurity doped fiber. The second optical multiplexer/demultiplexer transmits the optical signal onto the main optical transmission line and also transmits a leaked part of the excitation light onto the second subordinate optical transmission line.

It is preferable to further comprise an optical reflecting mirror provided on the second subordinate optical transmission line for reflecting the leaked part of the excitation light to the impurity doped fiber.

It is preferable to further comprise a secondary excitation light source on the second subordinate optical transmission line.

PREFERRED EMBODIMENTS

FIRST EMBODIMENT

A first embodiment according to the present invention described in detail with reference to FIG. 1 which is a diagram illustrative of a first novel optical switch having a single input and two outputs. The optical switch has an input side coupler **21** which is connected to a first optical transmission line **110** on which an optical input signal is transmitted and then inputted into the optical switch. The optical

input signal has a wavelength of 1550 nanometers and an intensity of 0 dBm. The optical input signal is divided by the input side coupler **21** into two parts. The optical switch has second and third optical transmission lines **120** and **121** which are connected to the input side coupler **21**. The two divided optical signals are then transmitted through the second and third optical transmission lines **120** and **121** for output thereof. The second optical transmission line **120** is connected to a first output side coupler **22**. The third optical transmission line **121** is connected to a second output side optical coupler **23**. A first erbium doped fiber EDF**11** is provided on the second optical transmission line **120** between the input side coupler **21** and the first output side coupler **22**. A second erbium doped fiber EDF**12** is provided on the third optical transmission line **120** between the input side coupler **21** and the second output side coupler **23**. The first and second erbium doped fibers EDF**11** and EDF**12** have a length of 50 meters. The first and second erbium doped fibers EDF**11** and EDF**12** may be replaced by rare earth doped fibers. The two divided optical signals are transmitted through the first and second erbium doped fibers EDF**11** and EDF**12** respectively. The optical switch further has an excitation light switch **41** which is connected through a first excitation light transmission line **111** to the first output side coupler **22** as well as which is connected through a second excitation light transmission line **112** to the second output side coupler **23**. The optical switch further has an excitation light source **31** which is connected to the excitation light switch **41**. The excitation light source **31** emits an excitation light with a wavelength of 1480 nanometers. The excitation light switch **41** is operated to switch the excitation light to any one of the first and second excitation light transmission lines **111** and **112** to supply any one of the first and second erbium doped fibers EDF**11** and EDF**12**.

If the excitation light switch **41** is operated to switch to supply the excitation light to the first erbium doped fiber EDF**11**, then the first erbium doped fiber EDF**11** is excited whereby the divided optical signal with the wavelength of 1550 nanometers is transmitted through the first erbium doped fiber EDF**11** without any optical absorption and then the optical signal with an intensity of 0 dBm is outputted from the second optical transmission line **120**. Accurately, the majority part of the excitation light emitted from the excitation light source **31** is switched by the excitation light switch **41** to be fed through the first excitation light transmission line **111** and the first output side optical coupler **22** to the first erbium doped fiber EDF**11**. On the other hand, the minority part of the excitation light emitted from the excitation light source **31** might be leaked through the excitation light switch **41** whereby a leaked excitation light is then fed through the second output side optical coupler **23** to the second erbium doped fiber EDF**12**. However, the leaked excitation light is incapable of exciting the second erbium doped fiber EDF**12**, for which reason the divided optical signal with the wavelength of 1550 nanometers is absorbed into the second erbium doped fiber EDF**12**. As a result, an optical output signal from the third optical transmission line **121** has an intensity of -60 dBm or less. The excitation light switch **41** causes an insertion loss of 2 dB and a crosstalk of 20 dB which allow the optical switch to be free from any substantive insertion loss and a low or reduced crosstalk.

If the excitation light switch **41** is operated to switch to supply the excitation light to the second erbium doped fiber EDF**12**, then the second erbium doped fiber EDF**12** is excited whereby the divided optical signal with the wavelength of 1550 nanometers is transmitted through the second erbium doped fiber EDF**12** without any optical absorption

and then the optical signal with an intensity of 0 dBm is outputted from the third optical transmission line **121**. Accurately, the majority part of the excitation light emitted from the excitation light source **31** is switched by the excitation light switch **41** to be fed through the second excitation light transmission line **112** and the second output optical coupler **23** to the second erbium doped fiber EDF**12**. On the other hand, the minority part of the excitation light emitted from the excitation light source **31** might be leaked through the excitation light switch **41** whereby a leaked excitation light is then fed through the first output side optical coupler **22** to the first erbium doped fiber EDF**11**. However, the leaked excitation light is incapable of exciting the first erbium doped fiber EDF**11**, for which reason the divided optical signal with the wavelength of 1550 nanometers is absorbed into the first erbium doped fiber EDF**11**. As a result, an optical output signal from the third optical transmission line **121** has an intensity of -60 dBm or less. The excitation light switch **41** causes an insertion loss of 2 dB and a crosstalk of 20 dB which allow the optical switch to be free from any substantive insertion loss and a low or reduced crosstalk.

As a modification to the above first embodiment, the above excitation light switch **41** may be replaced by a polymer optical switch.

If the polymer optical switch **41** is operated to switch to supply the excitation light to the first erbium doped fiber EDF**11**, then the first erbium doped fiber EDF**11** is excited whereby the divided optical signal with the wavelength of 1550 nanometers is transmitted through the first erbium doped fiber EDF**11** without any optical absorption and then the optical signal with an intensity of 0 dBm is outputted from the second optical transmission line **120**. Accurately, the majority part of the excitation light emitted from the excitation light source **31** is switched by the polymer optical switch **41** to be fed through the first excitation light transmission line **111** and the first output side optical coupler **22** to the first erbium doped fiber EDF**11**. On the other hand, the minority part of the excitation light emitted from the excitation light source **31** might be leaked through the polymer optical switch **41** whereby a leaked excitation light is then fed through the second output side optical coupler **23** to the second erbium doped fiber EDF**12**. However, the leaked excitation light is incapable of exciting the second erbium doped fiber EDF**12**, for which reason the divided optical signal with the wavelength of 1550 nanometers is absorbed into the second erbium doped fiber EDF**12**. As a result, an optical output signal from the third optical transmission line **121** has an intensity of -60 dBm or less. The polymer optical switch **41** causes an insertion loss of 2 dB and a crosstalk of 20 dB which allow the optical switch to be free from any substantive insertion loss and a low or reduced crosstalk.

If the polymer optical switch **41** is operated to switch to supply the excitation light to the second erbium doped fiber EDF**12**, then the second erbium doped fiber EDF**12** is excited whereby the divided optical signal with the wavelength of 1550 nanometers is transmitted through the second erbium doped fiber EDF**12** without any optical absorption and then the optical signal with an intensity of 0 dBm is outputted from the third optical transmission line **121**. Accurately, the majority part of the excitation light emitted from the excitation light source **31** is switched by the polymer optical switch **41** to be fed through the second excitation light transmission line **112** and the second output side optical coupler **23** to the second erbium doped fiber EDF**12**. On the other hand, the minority part of the excitation light emitted from the excitation light source **31** might

be leaked through the polymer optical switch **41** whereby a leaked excitation light is then fed through the first output side optical coupler **22** to the first erbium doped fiber EDF**11**. However, the leaked excitation light is incapable of exciting the first erbium doped fiber EDF**11**, for which reason the divided optical signal with the wavelength of 1550 nanometers is absorbed into the first erbium doped fiber EDF**11**. As a result, an optical output signal from the third optical transmission line **121** has an intensity of -60 dBm or less. The polymer optical switch **41** causes an insertion loss of 2 dB and a crosstalk of 20 dB which allow the optical switch to be free from any substantive insertion loss and a low or reduced crosstalk.

As a further modification to the above first embodiment, the excitation light has a wavelength of 980 nanometers in order to shorten the wavelength for a remarkable reduction in noise factor of the optical output signal. In this case, the optical switch is also free from any substantive insertion loss and a low or reduced crosstalk.

In the above embodiment, the number of the wavelength multiplexing on each optical transmission line is one. Notwithstanding, 8, 16, 32, 64-wavelength multiplexing are available, wherein the batch-switching operation to the plural number wavelength multiplexing is carried out.

It is also possible to set the wavelength of the optical input signal at not only 1550 nanometers but also other wavelengths, for example, 1330 nanometers.

It is also possible to set the wavelength of the excitation light at not only 1480 nanometers or 980 nanometers but also other wavelengths provided that such wavelength is capable of exciting the impurity doped fiber. It is preferable to set the wavelength of the excitation light in consideration of both the wavelength of the optical input signal and the kind of the impurity doped fiber.

The above excitation light switch may also be replaced by an acousto-optical switch, or a quartz-based switch.

It is further possible to control an intensity of the optical output signal by controlling an optical power of the excitation light to be fed to the impurity doped fiber. It is possible to control the optical power of the excitation light to be fed to the impurity doped fiber by controlling an injection current to the excitation light source or by use of variable or fixed attenuator.

It is furthermore possible to replace the erbium doped fiber by rare earth doped fiber as tellurium doped fiber. The length of the rare earth doped fiber and a doping concentration thereof may be set in accordance with the required specifications of the optical switch.

It is moreover possible to input the excitation light into the rare earth doped fiber in either directions or in both directions.

It is still more possible to conduct a polarization-multiplexing to different excitation lights emitted separately from plural different excitation light sources in order to input the polarization-multiplexed excitation light into the rare earth doped fiber to obtain a high gain.

It is yet more possible to set freely a ratio of optical division at the optical coupler in accordance with the various design choices.

The provisions of the smaller number of the excitation light source and the single excitation light switch permit ON-OFF switching operations of the plural gate switches by a simple structure. The above switch exhibits such a gain property as a sharp rising, for which reason there is substantially no influence due to a leaked light from the

excitation light switch. This makes the switch available to switches having relatively large crosstalk levels such as a polymer type switch or LiNbO₃ switch, thereby realizing a low crosstalk and low insertion loss optical switch. In addition, the use of the impurity doped fiber serving as an optical power amplifier can obtain a gain as the optical switch.

SECOND EMBODIMENT

A second embodiment according to the present invention will be described in detail with reference to FIG. **2** which is a diagram illustrative of a second novel optical switch having a single input and two outputs. A structural difference of the second novel optical switch from the first novel optical switch is only in further providing first and second optical filters on two output sides in order to eliminate or remove amplifier noises from the optical output signals.

The optical switch has an input side coupler **21** which is connected to a first optical transmission line **110** on which an optical input signal is transmitted and then inputted into the optical switch. The optical input signal has a wavelength of 1550 nanometers and an intensity of 0 dBm. The optical input signal is divided by the input side coupler **21** into two parts. The optical switch has second and third optical transmission lines **120** and **121** which are connected to the input side coupler **21**. The two divided optical signals are then transmitted through the second and third optical transmission lines **120** and **121** for output thereof. The second optical transmission line **120** is connected to a first output side coupler **22**. The third optical transmission line **121** is connected to a second output side optical coupler **23**. A first erbium doped fiber EDF**11** is provided on the second optical transmission line **120** between the input side coupler **21** and the first output side coupler **22**. A second erbium doped fiber EDF**12** is provided on the third optical transmission line **120** between the input side coupler **21** and the second output side coupler **23**. The first and second erbium doped fibers EDF**11** and EDF**12** have a length of 50 meters. The first and second erbium doped fibers EDF**11** and EDF**12** may be replaced by rare earth doped fibers. The two divided optical signals are transmitted through the first and second erbium doped fibers EDF**11** and EDF**12** respectively. The optical switch further has an excitation light switch **41** which is connected through a first excitation light transmission line **111** to the first output side coupler **22** as well as which is connected through a second excitation light transmission line **112** to the second output side coupler **23**. The optical switch further has an excitation light source **31** which is connected to the excitation light switch **41**. The excitation light source **31** emits an excitation light with a wavelength of 1480 nanometers. The excitation light switch **41** is operated to switch the excitation light to any one of the first and second excitation light transmission lines **111** and **112** to supply any one of the first and second erbium doped fibers EDF**11** and EDF**12**.

Further, in this second embodiment, a first optical filter **51** is provided on the second optical transmission line **120** and positioned closer to the output side than the first output side optical coupler **22**. If the first erbium doped fiber EDF**11** is excited, then this first erbium doped fiber EDF**11** also serves as an optical power amplifier which, however, amplifies not only the divided optical signal from the first optical transmission line **110** but also noises included in the optical signals, for which reason it is preferable to remove or eliminate the noises from the optical output signal by the first optical filter **51** in order to avoid deterioration in signal-to-noise ratio due to provision of the excitation light switch **41**. Similarly, a second optical filter **52** is provided on

the third optical transmission line **121** and positioned closer to the output side than the second output side optical coupler **23**. If the second erbium doped fiber EDF**12** is excited, then this second erbium doped fiber EDF**12** also serves as an optical power amplifier which, however, amplifies not only the divided optical signal from the first optical transmission line **110** but also noises included in the optical signals; for which reason it is preferable to remove or eliminate the noises from the optical output signal by the second optical filter **52** in order to avoid deterioration in signal-to-noise ratio due to provision of the excitation light switch **41**.

If the excitation light switch **41** is operated to switch to supply the excitation light to the first erbium doped fiber EDF**11**, then the first erbium doped fiber EDF**11** is excited whereby the divided optical signal with the wavelength of 1550 nanometers is transmitted through the first erbium doped fiber EDF**11** without any optical absorption. The optical output signal is then fed to the first optical filter **51** to remove or eliminate the noises from the optical output signal by the first optical filter **51** in order to avoid deterioration in signal-to-noise ratio due to provision of the excitation light switch **41**. Therefore, the optical signal filtered in wavelength and having an intensity of 0 dBm is outputted from the second optical transmission line **120**. Accurately, the majority part of the excitation light emitted from the excitation light source **31** is switched by the excitation light switch **41** to be fed through the first excitation light transmission line **111** and the first output side optical coupler **22** to the first erbium doped fiber EDF**11**. On the other hand, the minority part of the excitation light emitted from the excitation light source **31** might be leaked through the excitation light switch **41** whereby a leaked excitation light is then fed through the second output side optical coupler **23** to the second erbium doped fiber EDF**12**. However, the leaked excitation light is incapable of exciting the second erbium doped fiber EDF**12**, for which reason the divided optical signal with the wavelength of 1550 nanometers is absorbed into the second erbium doped fiber EDF**12**. As a result, an optical output signal from the third optical transmission line **121** is free of any substantive noise and has an intensity of -60 dBm or less. The excitation light switch **41** causes an insertion loss of 2 dB and a crosstalk of 20 dB which allow the optical switch to be free from any substantive insertion loss and a low or reduced crosstalk.

If the excitation light switch **41** is operated to switch to supply the excitation light to the second erbium doped fiber EDF**12**, then the second erbium doped fiber EDF**12** is excited whereby the divided optical signal with the wavelength of 1550 nanometers is transmitted through the second erbium doped fiber EDF**12** without any optical absorption. The optical output signal is then fed to the second optical filter **52** to remove or eliminate the noises from the optical output signal by the second optical filter **52** in order to avoid deterioration in signal-to-noise ratio due to provision of the excitation light switch **41**. Therefore, the optical signal filtered in wavelength and having an intensity of 0 dBm is outputted from the second optical transmission line **120**. Accurately, the majority part of the excitation light emitted from the excitation light source **31** is switched by the excitation light switch **41** to be fed through the second excitation light transmission line **112** and the second output side optical coupler **23** to the second erbium doped fiber EDF**12**. On the other hand, the minority part of the excitation light emitted from the excitation light source **31** might be leaked through the excitation light switch **41** whereby a leaked excitation light is then fed through the first output side optical coupler **22** to the first erbium doped fiber

EDF**11**. However, the leaked excitation light is incapable of exciting the first erbium doped fiber EDF**11**, for which reason the divided optical signal with the wavelength of 1550 nanometers is absorbed into the first erbium doped fiber EDF**11**. As a result, an optical output signal from the third optical transmission line **121** is free of any substantive noise and has an intensity of -60 dBm or less. The excitation light switch **41** causes an insertion loss of 2 dB and a crosstalk of 20 dB which allow the optical switch to be free from any substantive insertion loss and a low or reduced crosstalk.

As a modification to the above second embodiment, the above excitation light switch **41** may be replaced by a polymer optical switch similarly to the first embodiment.

If the polymer optical switch **41** is operated to switch to supply the excitation light to the first erbium doped fiber EDF**11**, then the first erbium doped fiber EDF**11** is excited whereby the divided optical signal with the wavelength of 1550 nanometers is transmitted through the first erbium doped fiber EDF**11** without any optical absorption. The optical output signal is then fed to the first optical filter **51** to remove or eliminate the noises from the optical output signal by the first optical filter **51** in order to avoid deterioration in signal-to-noise ratio due to provision of the polymer optical switch **41**. Therefore, the optical signal filtered in wavelength and having an intensity of 0 dBm is outputted from the second optical transmission line **120**. Accurately, the majority part of the excitation light emitted from the excitation light source **31** is switched by the polymer optical switch **41** to be fed through the first excitation light transmission line **111** and the first output side optical coupler **22** to the first erbium doped fiber EDF**11**. On the other hand, the minority part of the excitation light emitted from the excitation light source **31** might be leaked through the polymer optical switch **41** whereby a leaked excitation light is then fed through the second output side optical coupler **23** to the second erbium doped fiber EDF**12**. However, the leaked excitation light is incapable of exciting the second erbium doped fiber EDF**12**, for which reason the divided optical signal with the wavelength of 1550 nanometers is absorbed into the second erbium doped fiber EDF**12**. As a result, an optical output signal from the third optical transmission line **121** is free of any substantive noise and has an intensity of -60 dBm or less. The polymer optical switch **41** causes an insertion loss of 2 dB and a crosstalk of 20 dB which allow the optical switch to be free from any substantive insertion loss and a low or reduced crosstalk.

If the polymer optical switch **41** is operated to switch to supply the excitation light to the second erbium doped fiber EDF**12**, then the second erbium doped fiber EDF**12** is excited whereby the divided optical signal with the wavelength of 1550 nanometers is transmitted through the second erbium doped fiber EDF**12** without any optical absorption. The optical output signal is then fed to the second optical filter **52** to remove or eliminate the noises from the optical output signal by the second optical filter **52** in order to avoid deterioration in signal-to-noise ratio due to provision of the polymer optical switch **41**. Therefore, the optical signal filtered in wavelength and having an intensity of 0 dBm is outputted from the second optical transmission line **120**. Accurately, the majority part of the excitation light emitted from the excitation light source **31** is switched by the polymer optical switch **41** to be fed through the second excitation light transmission line **112** and the second output side optical coupler **23** to the second erbium doped fiber EDF**12**. On the other hand, the minority part of the excitation light emitted from the excitation light source **31** might

be leaked through the polymer optical switch **41** whereby a leaked excitation light is then fed through the first output side optical coupler **22** to the first erbium doped fiber EDF**11**. However, the leaked excitation light is incapable of exciting the first erbium doped fiber EDF**11**, for which reason the divided optical signal with the wavelength of 1550 nanometers is absorbed into the first erbium doped fiber EDF**11**. As a result, an optical output signal from the third optical transmission line **121** is free of any substantive noise and has an intensity of -60 dBm or less. The polymer optical switch **41** causes an insertion loss of 2 dBm and a crosstalk of 20 dB which allow the optical switch to be free from any substantive insertion loss and a low or reduced crosstalk.

As a further modification to the above second embodiment, the excitation light has a wavelength of 980 nanometers in order to shorten the wavelength for a remarkable reduction in noise factor of the optical output signal. In this case, the optical switch is also free from any substantive insertion loss and a low or reduced crosstalk.

In the above embodiment, the number of the wavelength multiplexing on each optical transmission line is one. Notwithstanding, 8, 16, 32, 64-wavelength multiplexing are available, wherein the batch-switching operation to the plural number wavelength multiplexing is carried out.

It is also possible to set the wavelength of the optical input signal at not only 1550 nanometers but also other wavelengths, for example, 1330 nanometers.

It is also possible to set the wavelength of the excitation light at not only 1480 nanometers or 980 nanometers but also other wavelengths provided that such wavelength is capable of exciting the impurity doped fiber. It is preferable to set the wavelength of the excitation light in consideration of both the wavelength of the optical input signal and the kind of the impurity doped fiber.

The above excitation light switch may also be replaced by an acousto-optical switch, or a quartz-based switch.

It is further possible to control an intensity of the optical output signal by controlling an optical power of the excitation light to be fed to the impurity doped fiber. It is possible to control the optical power of the excitation light to be fed to the impurity doped fiber by controlling an injection current to the excitation light source or by use of variable or fixed attenuator.

It is furthermore possible to replace the erbium doped fiber by rare earth doped fiber such as tellurium doped fiber. The length of the rare earth doped fiber and a doping concentration thereof may be set in accordance with the required specifications of the optical switch.

It is moreover possible to input the excitation light into the rare earth doped fiber in either directions or in both directions.

It is still more possible to conduct a polarization-multiplexing to different excitation lights emitted separately from plural different excitation light sources in order to input the polarization-multiplexed excitation light into the rare earth doped fiber to obtain a high gain.

It is yet more possible to set freely a ratio of optical division at the optical coupler in accordance with the various design choices.

It is still further possible to freely set the transmission-band width in accordance with the number of the optical signals to be transmitted through the optical switch.

It is yet further possible to provide optical filters and optical isolators since the excitation light and returned light provide no influence to input and output sides of the optical switch.

The provisions of the smaller number of the excitation light source and the single excitation light switch permit ON-OFF switching operations of the plural gate switches by a simple structure. The above switch exhibits such a gain property as a sharp rising, for which reason there is substantially no influence due to a leaked light from the excitation light switch. This makes the switch available to switches having relatively large crosstalk levels such as a polymer type switch or LiNbO₃ switch, thereby realizing a low crosstalk and low insertion loss optical switch. In addition, the use of the impurity doped fiber serving as an optical power amplifier can obtain a gain as the optical switch.

THIRD EMBODIMENT

A third embodiment according to the present invention will be described in detail with reference to FIG. **3** which is a diagram illustrative of a third novel optical switch having a single input and two outputs. A structural difference of the third novel optical switch from the first novel optical switch is in further providing first and second optical isolators as well as first and second optical mirrors in order to increase an efficiency of excitation of the erbium doped fiber with allowance of a sufficient optical absorption.

The optical switch has an input side coupler **21** which is connected to a first optical transmission line **110** on which an optical input signal is transmitted and then inputted into the optical switch. The optical input signal has a wavelength of 1550 nanometers and an intensity of 0 dBm. The optical input signal is divided by the input side coupler **21** into two parts. The optical switch has second and third optical transmission lines **120** and **121** which are connected to the input side coupler **21**. The two divided optical signals are then transmitted through the second and third optical transmission lines **120** and **121** for output thereof. The second optical transmission line **120** is connected to a first output side coupler **22**. The third optical transmission line **121** is connected to a second output side optical coupler **23**. A first erbium doped fiber EDF**11** is provided on the second optical transmission line **120** between the input side coupler **21** and the first output side coupler **22**. A second erbium doped fiber EDF**12** is provided on the third optical transmission line **120** between the input side coupler **21** and the second output side coupler **23**. The first and second erbium doped fibers EDF**11** and EDF**12** have a length of 50 meters. The first and second erbium doped fibers EDF**11** and EDF**12** may be replaced by rare earth doped fibers. The two divided optical signals are transmitted through the first and second erbium doped fibers EDF**11** and EDF**12** respectively. The optical switch further has an excitation light switch **41** which is connected through a first excitation light transmission line **111** to the first output side coupler **22** as well as which is connected through a second excitation light transmission line **112** to the second output side coupler **23**. The optical switch further has an excitation light source **31** which is connected to the excitation light switch **41**. The excitation light source **31** emits an excitation light with a wavelength of 1480 nanometers. The excitation light switch **41** is operated to switch the excitation light to any one of the first and second excitation light transmission lines **111** and **112** to supply any one of the first and second erbium doped fibers EDF**11** and EDF**12**.

In addition, a first optical isolator **61** is provided on the second optical transmission line **120** and positioned between the input side optical coupler **21** and the first erbium doped fiber EDF**11**. The first optical isolator **61** permits only a unidirectional transmission of the optical signal from the input side optical coupler **21** to the first erbium doped fiber

EDF11, however, preventing an opposite direction transmission of the optical signal from the first erbium doped fiber EDF11 to the input side optical coupler 21. A second optical isolator 62 is provided on the third optical transmission line 121 and positioned between the input side optical coupler 21 and the second erbium doped fiber EDF12. The second optical isolator 62 permits only a unidirectional transmission of the optical signal from the input side optical coupler 21 to the second erbium doped fiber EDF12, however, preventing an opposite direction transmission of the optical signal from the second erbium doped fiber EDF12 to the input side optical coupler 31. Moreover, a first optical reflective mirror 71 is provided on a first terminal of the second optical transmission line 120 so that the divided optical signal having passed through the first erbium doped fiber EDF11 is reflected by the first optical reflective mirror 71 toward the first erbium doped fiber EDF11, whereby the divided optical signal passes through the first erbium doped fiber EDF11 two times. If the first erbium doped fiber EDF11 is excited, then this first erbium doped fiber EDF11 serves as an amplifier. This two times transmissions of the divided optical signal by the first optical reflective mirror 71 increases the efficiency of the excitation of the first erbium doped fiber EDF11 even if the power of the excitation light emitted from the excitation light source 31 is not so high. The reflected optical signal is thus transmitted through the first erbium doped fiber EDF11 and divided into two parts, wherein one of the further divided parts of the reflected optical signal is outputted from an output terminal of a fourth optical transmission line 122 whilst transmission of the remaining one of the further divided parts of the reflected optical signal is discontinued by the first optical isolator 61 so that no light is transmitted back to the first optical transmission line 110. Furthermore, a second optical reflective mirror 72 is provided on a second terminal of the third optical transmission line 121 so that the divided optical signal having passed through the second erbium doped fiber EDF12 is reflected by the second optical reflective mirror 72 toward the second erbium doped fiber EDF12, whereby the divided optical signal passes through the second erbium doped fiber EDF12 two times. If the second erbium doped fiber EDF12 is excited, then this second erbium doped fiber EDF12 serves as an amplifier. This two times transmissions of the divided optical signal by the second optical reflective mirror 72 increases the efficiency of the excitation of the second erbium doped fiber EDF12 even if the power of the excitation light emitted from the excitation light source 31 is not so high. The reflected optical signal is thus transmitted through the second erbium doped fiber EDF12 and divided into two parts, wherein one of the further divided parts of the reflected optical signal is outputted from an output terminal of a fifth optical transmission line 123 whilst transmission of the remaining one of the further divided parts of the reflected optical signal is discontinued by the second optical isolator 62 so that no light is transmitted back to the first optical transmission line 110.

If the excitation light switch 41 is operated to switch to supply the excitation light to the first erbium doped fiber EDF11, then the first erbium doped fiber EDF11 is excited whereby the divided optical signal with the wavelength of 1550 nanometers is transmitted through the first erbium doped fiber EDF11 without any optical absorption and then the optical signal is reflected by the first optical reflective mirror 71 for subsequent returning to the first erbium doped fiber EDF11. This two times transmissions of the divided optical signal by the first optical reflective mirror 71 increases the efficiency of the excitation of the first erbium

doped fiber EDF11 even if the power of the excitation light emitted from the excitation light source 31 is not so high. The reflected optical signal is thus transmitted through the first erbium doped fiber EDF11 and divided by an optical coupler into two parts, wherein one of the further divided parts of the reflected optical signal is outputted from an output terminal of a fourth optical transmission line 122 whilst transmission of the remaining one of the further divided parts of the reflected optical signal is discontinued by the first optical isolator 61 so that no light is transmitted back to the first optical transmission line 110. The optical signal with an intensity of 0 dB is outputted from the output terminal of the fourth optical transmission line 122. Accurately, the majority part of the excitation light emitted from the excitation light source 31 is switched by the excitation light switch 41 to be fed through the first excitation light transmission line 111 and the first output side optical coupler 22 to the first erbium doped fiber EDF11. On the other hand, the minority part of the excitation light emitted from the excitation light source 31 might be leaked through the excitation light switch 41 whereby a leaked excitation light is then fed through the second output side optical coupler 23 to the second erbium doped fiber EDF12. However, the leaked excitation light is incapable of exciting the second erbium doped fiber EDF12, for which reason the divided optical signal with the wavelength of 1550 nanometers is absorbed into the second erbium doped fiber EDF12. A leaked divided optical signal is also reflected by the second optical reflective mirror 72 and the reflected leaked optical signal is again transmitted through the second erbium doped fiber EDF12. As a result, an optical output signal from the fifth optical transmission line 123 has an intensity of -80 dBm or less. The excitation light switch 41 causes an insertion loss of 2 dB and a crosstalk of 20 dB which allow the optical switch to be free from any substantive insertion loss and a low or reduced crosstalk.

If the excitation light switch 41 is operated to switch to supply the excitation light to the second erbium doped fiber EDF12, then the second erbium doped fiber EDF12 is excited whereby the divided optical signal with the wavelength of 1550 nanometers is transmitted through the second erbium doped fiber EDF12 without any optical absorption and then the optical signal is reflected by the second optical reflective mirror 72 for subsequent returning to the second erbium doped fiber EDF12. This two times transmissions of the divided optical signal by the second optical reflective mirror 72 increases the efficiency of the excitation of the second erbium doped fiber EDF12 even if the power of the excitation light emitted from the excitation light source 31 is not so high. The reflected optical signal is thus transmitted through the second erbium doped fiber EDF12 and divided by the optical coupler into two parts, wherein one of the further divided parts of the reflected optical signal is outputted from an output terminal of a fifth optical transmission line 123 whilst transmission of the remaining one of the further divided parts of the reflected optical signal is discontinued by the second optical isolator 62 so that no light is transmitted back to the first optical transmission line 110. The optical signal with an intensity of 0 dBm is outputted from the output terminal of the fourth optical transmission line 122. Accurately, the majority part of the excitation light emitted from the excitation light source 31 is switched by the excitation light switch 41 to be fed through the second excitation light transmission line 112 and the second output side optical coupler 23 to the second erbium doped fiber EDF12. On the other hand, the minority part of the excitation light emitted from the excitation light source 31 might

be leaked through the excitation light switch **41** whereby a leaked excitation light is then fed through the first output side optical coupler **22** to the first erbium doped fiber EDF**11**. However, the leaked excitation light is incapable of exciting the first erbium doped fiber EDF**11**, for which reason the divided optical signal with the wavelength of 1550 nanometers is absorbed into the first erbium doped fiber EDF**11**. A leaked divided optical signal is also reflected by the first optical reflective mirror **71** and the reflected leaked optical signal is again transmitted through the first erbium doped fiber EDF**11**. As a result, an optical output signal from the fourth optical transmission line **122** has an intensity of -80 dBm or less. The excitation light switch **41** causes an insertion loss of 2 dB and a crosstalk of 20 dB which allow the optical switch to be free from any substantive insertion loss and a low or reduced crosstalk.

As a modification to the above third embodiment, the above excitation light switch **41** may be replaced by a polymer optical switch.

If the polymer optical switch **41** is operated to switch to supply the excitation light to the first erbium doped fiber EDF**11**, then the first erbium doped fiber EDF**11** is excited whereby the divided optical signal with the wavelength of 1550 nanometers is transmitted through the first erbium doped fiber EDF**11** without any optical absorption and then the optical signal is reflected by the first optical reflective mirror **71** for subsequent returning to the first erbium doped fiber EDF**11**. This two times transmissions of the divided optical signal by the first optical reflective mirror **71** increases the efficiency of the excitation of the first erbium doped fiber EDF**11** even if the power of the excitation light emitted from the excitation light source **31** is not so high. The reflected optical signal is thus transmitted through the first erbium doped fiber EDF**11** and divided by an optical coupler into two parts, wherein one of the further divided parts of the reflected optical signal is outputted from an output terminal of a fourth optical transmission line **122** whilst transmission of the remaining one of the further divided parts of the reflected optical signal is discontinued by the first optical isolator **61** so that no light is transmitted back to the first optical transmission line **110**. The optical signal with an intensity of 0 dBm is outputted from the output terminal of the fourth object transmission line **122**. Accurately, the majority part of the excitation light emitted from the excitation light source **31** is switched by the polymer optical switch **41** to be fed through the first excitation light transmission line **111** and the first output side optical coupler **22** to the first erbium doped fiber EDF**11**. On the other hand, the minority part of the excitation light emitted from the excitation light source **31** might be leaked through the polymer optical switch **41** whereby a leaked excitation light is then fed through the second output side optical coupler **23** to the second erbium doped fiber EDF**12**. However, the leaked excitation light is incapable of exciting the second erbium doped fiber EDF**12**, for which reason the divided optical signal with the wavelength of 1550 nanometers is absorbed into the second erbium doped fiber EDF**12**. A leaked divided optical signal is also reflected by the second optical reflective mirror **72** and the reflected leaked optical signal is again transmitted through the second erbium doped fiber EDF**12**. As a result, an optical output signal from the fifth optical transmission line **123** has an intensity of -80 dBm or less. The polymer optical switch **41** causes an insertion loss of 2 dB and a crosstalk of 20 dB which allow the optical switch to be free from any substantive insertion loss and a low or reduced crosstalk.

If the polymer optical switch **41** is operated to switch to supply the excitation light to the second erbium doped fiber

EDF**12**, then the second erbium doped fiber EDF**12** is excited whereby the divided optical signal with the wavelength of 1550 nanometers is transmitted through the second erbium doped fiber EDF**12** without any optical absorption and then the optical signal is reflected by the second optical reflective mirror **72** for subsequent returning to the second erbium doped fiber EDF**12**. This two times transmissions of the divided optical signal by the second optical reflective mirror **72** increases the efficiency of the excitation of the second erbium doped fiber EDF**12** even if the power of the excitation light emitted from the excitation light source **31** is not so high. The reflected optical signal is thus transmitted through the second erbium doped fiber EDF**12** and divided by an optical coupler into two parts, wherein one of the further divided parts of the reflected optical signal is outputted from an output terminal of a fifth optical transmission line **123** whilst transmission of the remaining one of the further divided parts of the reflected optical signal is discontinued by the second optical isolator **62** so that no light is transmitted back to the first optical transmission line **110**. The optical signal with an intensity of 0 dBm is outputted from the output terminal of the fourth optical transmission line **122**. Accurately, the majority part of the excitation light emitted from the excitation light source **31** is switched by the polymer optical switch **41** to be fed through the second excitation light transmission line **112** and the second output side optical coupler **23** to the second erbium doped fiber EDF**12**. On the other hand, the minority part of the excitation light emitted from the excitation light source **31** might be leaked through the polymer optical switch **41** whereby a leaked excitation light is then fed through the first output side optical coupler **22** to the first erbium doped fiber EDF**11**. However, the leaked excitation light is incapable of exciting the first erbium doped fiber EDF**11**, for which reason the divided optical signal with the wavelength of 1550 nanometers is absorbed into the first erbium doped fiber EDF**11**. A leaked divided optical signal is also reflected by the first optical reflective mirror **71** and the reflected leaked optical signal is again transmitted through the first erbium doped fiber EDF**11**. As a result, an optical output signal from the fourth optical transmission line **122** has an intensity of -80 dBm or less. The polymer optical switch **41** causes an insertion loss of 2 dB and a crosstalk of 20 dB which allow the optical switch to be free from any substantive insertion loss and a low or reduced crosstalk.

As a further modification to the above third embodiment, the excitation light has a wavelength of 980 nanometers in order to shorten the wavelength for a remarkable reduction in noise factor of the optical output signal. In this case, the optical switch is also free from any substantive insertion loss and a low or reduced crosstalk.

In the above embodiment, the number of the wavelength multiplexing on each optical transmission line is one. Notwithstanding, 8, 16, 32, 64-wavelength multiplexing are available, wherein the batch-switching operation to the plural number wavelength multiplexing is carried out.

It is also possible to set the wavelength of the optical input signal at not only 1550 nanometers but also other wavelengths, for example, 1330 nanometers.

It is also possible to set the wavelength of the excitation light at not only 1480 nanometers or 980 nanometers but also other wavelengths provided that such wavelength is capable of exciting the impurity doped fiber. It is preferable to set the wavelength of the excitation light in consideration of both the wavelength of the optical input signal and the kind of the impurity doped fiber.

The above excitation light switch may also be replaced by an acousto-optical switch, or a quartz-based switch.

It is further possible to control an intensity of the optical output signal by controlling an optical power of the excitation light to be fed to the impurity doped fiber. It is possible to control the optical power of the excitation light to be fed to the impurity doped fiber by controlling an injection current to the excitation light source or by use of variable or fixed attenuator.

It is furthermore possible to replace the erbium doped fiber by rare earth doped fiber such as tellurium doped fiber. The length of the rare earth doped fiber and a doping concentration thereof may be set in accordance with the required specifications of the optical switch.

It is moreover possible to input the excitation light into the rare earth doped fiber in either directions or in both directions.

It is still more possible to conduct a polarization-multiplexing to different excitation lights emitted separately from plural different excitation light sources in order to input the polarization-multiplexed excitation light into the rare earth doped fiber to obtain a high gain.

It is yet more possible to set freely a ratio of optical division at the optical coupler in accordance with the various design choices.

It is still further possible that the optical input and output transmission lines are used commonly or separately according to the required optical system.

It is yet further possible to replace the input side coupler 21 and the first and second optical isolators 61 and 62 by a circulator.

It is additionally possible to provide optical reflective mirrors having fixed or variable reflectivity as the first and second optical reflective mirrors 71 and 72. If the variable reflectivity type optical reflective mirrors are provided, it is possible to control the optical powers of the output signals.

The provisions of the smaller number of the excitation light source and the single excitation light switch permit ON-OFF switching operations of the plural gate switches by a simple structure. The above switch exhibits such a gain property as a sharp rising, for which reason there is substantially no influence due to a leaked light from the excitation light switch. This makes the switch available to switches having relatively large crosstalk levels such as a polymer type switch or LiNbO₃ switch, thereby realizing a low crosstalk and low insertion loss optical switch. In addition, the use of the impurity doped fiber serving as an optical power amplifier can obtain a gain as the optical switch.

FOURTH EMBODIMENT

A fourth embodiment according to the present invention will be described in detail with reference to FIG. 4 which is a diagram illustrative of a fourth novel optical switch having a single input and two outputs. A structural difference of the fourth novel optical switch from the first novel optical switch is in positions of first and second erbium doped fibers so that first and second erbium doped fibers receive an excitation light in the same direction as receipt of the optical signals, whilst in the first embodiment the first and second erbium doped fibers receive the excitation light in the opposite direction to the receipt of the optical signals.

The optical switch has an input side coupler 21 which is connected to a first optical transmission line 110 on which an optical input signal is transmitted and then inputted into the optical switch. The optical input signal has a wavelength of 1550 nanometers and an intensity of 0 dBm. The optical

input signal is divided by the input side coupler 21 into two parts. The optical switch has second and third optical transmission lines 120 and 121 which are connected to the input side coupler 21. The two divided optical signals are then transmitted through the second and third optical transmission lines 120 and 121 for output thereof. The second optical transmission line 120 is connected to a first output side coupler 22. The third optical transmission line 121 is connected to a second output side optical coupler 23. A first erbium doped fiber EDF11 is provided on the second optical transmission line 120 and positioned between the first output side coupler 22 and the output terminal of the second optical transmission line 120. A second erbium doped fiber EDF12 is provided on the third optical transmission line 120 and positioned between the second output side coupler 23 and the output terminal of the third optical transmission line 121. The first and second erbium doped fibers EDF11 and EDF12 have a length of 50 meters. The first and second erbium doped fibers EDF11 and EDF12 may be replaced by rare earth doped fibers. The two divided optical signals are transmitted through the first and second erbium doped fibers EDF11 and EDF12 respectively. The optical switch further has an excitation light switch 41 which is connected through a first excitation light transmission line 111 to the first output side coupler 22 as well as which is connected through a second excitation light transmission line 112 to the second output side coupler 23. The optical switch further has an excitation light source 31 which is connected to the excitation light switch 41. The excitation light source 31 emits an excitation light with a wavelength of 1480 nanometers. The excitation light switch 41 is operated to switch the excitation light to any one of the first and second excitation light transmission lines 111 and 112 to supply any one of the first and second erbium doped fibers EDF11 and EDF12, so that the selected one of the first and second erbium doped fibers EDF11 and EDF12 receives the excitation light in the same direction as receipt of the optical signal.

If the excitation light switch 41 is operated to switch to supply the excitation light to the first erbium doped fiber EDF11 so that the first and second erbium doped fiber EDF11 receives the excitation light in the same direction as receipt of the optical signal, then the first erbium doped fiber EDF11 is excited whereby the divided optical signal with the wavelength of 1550 nanometers is transmitted through the first erbium doped fiber EDF11 without any optical absorption and then the optical signal with an intensity of 0 dBm is outputted from the second optical transmission line 120. Accurately, the majority part of the excitation light emitted from the excitation light source 31 is switched by the excitation light switch 41 to be fed through the first excitation light transmission line 111 and the first output side optical coupler 22 to the first erbium doped fiber EDF11. On the other hand, the minority part of the excitation light emitted from the excitation light source 31 might be leaked through the excitation light switch 41 whereby a leaked excitation light is then fed through the second output side optical coupler 23 to the second erbium doped fiber EDF12. However, the leaked excitation light is incapable of exciting the second erbium doped fiber EDF12, for which reason the divided optical signal with the wavelength of 1550 nanometers is absorbed into the second erbium doped fiber EDF12. As a result, an optical output signal from the third optical transmission line 121 has an intensity of -60 dBm or less. The excitation light switch 41 causes an insertion loss of 2 dB and a crosstalk of 20 dB which allow the optical switch to be free from any substantive insertion loss and a low or reduced crosstalk.

If the excitation light switch **41** is operated to switch to supply the excitation light to the second erbium doped fiber EDF12 so that the second erbium doped fiber EDF12 receives the excitation light in the same direction as receipt of the optical signal, then the second erbium doped fiber EDF12 is excited whereby the divided optical signal with the wavelength of 1550 nanometers is transmitted through the second erbium doped fiber EDF12 without any optical absorption and then the optical signal with an intensity of 0 dBm is outputted from the third optical transmission line **121**. Accurately, the majority part of the excitation light emitted from the excitation light source **31** is switched by the excitation light switch **41** to be fed through the second excitation light transmission line **112** and the second output side optical coupler **23** to the second erbium doped fiber EDF12. On the other hand, the minority part of the excitation light emitted from the excitation light source **31** might be leaked through the excitation light switch **41** whereby a leaked excitation light is then fed through the first output side optical coupler **22** to the first erbium doped fiber EDF11. However, the leaked excitation light is incapable of exciting the first erbium doped fiber EDF11, for which reason the divided optical signal with the wavelength of 1550 nanometers is absorbed into the first erbium doped fiber EDF11. As a result, an optical output signal from the third optical transmission line **121** has an intensity of -60 dBm or less. The excitation light switch **41** causes an insertion loss of 2 dB and a crosstalk of 20 dB which allow the optical switch to be free from any substantive insertion loss and a low or reduced crosstalk.

As a modification to the above first embodiment, the above excitation light switch **41** may be replaced by a polymer optical switch.

If the polymer optical switch **41** is operated to switch to supply the excitation light to the first erbium doped fiber EDF11 so that the first and second erbium doped fiber EDF11 receives the excitation light in the same direction as receipt of the optical signal, then the first erbium doped fiber EDF11 is excited whereby the divided optical signal with the wavelength of 1550 nanometers is transmitted through the first erbium doped fiber EDF11 without any optical absorption and then the optical signal with an intensity of 0 dBm is outputted from the second optical transmission line **120**. Accurately, the majority part of the excitation light emitted from the excitation light source **31** is switched by the polymer optical switch **41** to be fed through the first excitation light transmission line **111** and the first output side optical coupler **22** to the first erbium doped fiber EDF11. On the other hand, the minority part of the excitation light emitted from the excitation light source **31** might be leaked through the polymer optical switch **41** whereby a leaked excitation light is then fed through the second output side optical coupler **23** to the second erbium doped fiber EDF12. However, the leaked excitation light is incapable of exciting the second erbium doped fiber EDF12, for which reason the divided optical signal with the wavelength of 1550 nanometers is absorbed into the second erbium doped fiber EDF12. As a result, an optical output signal from the third optical transmission line **121** has an intensity of -60 dBm or less. The polymer optical switch **41** causes an insertion loss of 2 dB and a crosstalk of 20 dB which allow the optical switch to be free from any substantive insertion loss and a low or reduced crosstalk.

If the polymer optical switch **41** is operated to switch to supply the excitation light to the second erbium doped fiber EDF12 so that the second erbium doped fiber EDF12 receives the excitation light in the same direction as receipt

of the optical signal, then the second erbium doped fiber EDF12 is excited whereby the divided optical signal with the wavelength of 1550 nanometers is transmitted through the second erbium doped fiber EDF12 without any optical absorption and then the optical signal with an intensity of 0 dBm is outputted from the third optical transmission line **121**. Accurately, the majority part of the excitation light emitted from the excitation light source **31** is switched by the polymer optical switch **41** to be fed through the second excitation light transmission line **112** and the second output side optical coupler **23** to the second erbium doped fiber EDF12. On the other hand, the minority part of the excitation light emitted from the excitation light source **31** might be leaked through the polymer optical switch **41** whereby a leaked excitation light is then fed through the first output side optical coupler **22** to the first erbium doped fiber EDF11. However, the leaked excitation light is incapable of exciting the first erbium doped fiber EDF11, for which reason the divided optical signal with the wavelength of 1550 nanometers is absorbed into the first erbium doped fiber EDF11. As a result, an optical output signal from the third optical transmission line **121** has an intensity of -60 dBm or less. The polymer optical switch **41** causes an insertion loss of 2 dB and a crosstalk of 20 dB which allow the optical switch to be free from any substantive insertion loss and a low or reduced crosstalk.

As a further modification to the above first embodiment, the excitation light has a wavelength of 980 nanometers in order to shorten the wavelength for a remarkable reduction in noise factor of the optical output signal. In this case, the optical switch is also free from any substantive insertion loss and a low or reduced crosstalk.

In the above embodiment, the number of the wavelength multiplexing on each optical transmission line is one. Notwithstanding, 8, 16, 32, 64-wavelength multiplexing are available, wherein the batch-switching operation to the plural number wavelength multiplexing is carried out.

It is also possible to set the wavelength of the optical input signal at not only 1550 nanometers but also other wavelengths, for example, 1330 nanometers.

It is also possible to set the wavelength of the excitation light at not only 1480 nanometers or 980 nanometers but also other wavelengths provided that such wavelength is capable of exciting the impurity doped fiber. It is preferable to set the wavelength of the excitation light in consideration of both the wavelength of the optical input signal and the kind of the impurity doped fiber.

The above excitation light switch may also be replaced by an acousto-optical switch, or a quartz-based switch.

It is further possible to control an intensity of the optical output signal by controlling an optical power of the excitation light to be fed to the impurity doped fiber. It is possible to control the optical power of the excitation light to be fed to the impurity doped fiber by controlling an injection current to the excitation light source or by use of variable or fixed attenuator.

It is furthermore possible to replace the erbium doped fiber by rare earth doped fiber such as tellurium doped fiber. The length of the rare earth doped fiber and a doping concentration thereof may be set in accordance with the required specifications of the optical switch.

It is moreover possible to input the excitation light into the rare earth doped fiber in either directions or in both directions.

It is still more possible to conduct a polarization-multiplexing to different excitation lights emitted separately

from plural different excitation light sources in order to input the polarization-multiplexed excitation light into the rare earth doped fiber to obtain a high gain.

It is yet more possible to set freely a ratio of optical division at the optical coupler in accordance with the various design choices.

The provisions of the smaller number of the excitation light source and the single excitation light switch permit ON-OFF switching operations of the plural gate switches by a simple structure. The above switch exhibits such a gain property as a sharp rising, for which reason there is substantially no influence due to a leaked light from the excitation light switch. This makes the switch available to switches having relatively large crosstalk levels such as a polymer type switch or LiNbO_3 switch, thereby realizing a low crosstalk and low insertion loss optical switch. In addition, the use of the impurity doped fiber serving as an optical power amplifier can obtain a gain as the optical switch.

FIFTH EMBODIMENT

A fifth embodiment according to the present invention will be described in detail with reference to FIG. 5 which is a diagram illustrative of a fifth novel optical switch having two inputs and two outputs. The fifth novel optical switch comprises a pair of the above first novel optical switches described in the first embodiment. The two first novel optical switches are connected to each other through a first optical transmission line **110** as a common line. If the left side one of the paired first novel optical switches is in input side and the right side one of the paired first novel optical switches is in output side, then the switching operation of the left side one of the paired first novel optical switches is carried out to select or switch any one of the two inputs of the fifth novel optical switch having the two inputs and the two outputs, whilst the switching operation of the right side one of the paired first novel optical switches is carried out to select or switch any one of the two outputs of the fifth novel optical switch having the two inputs and the two outputs, whereby the switching operations of the paired first novel optical switches realize the fifth novel optical switch having the two inputs and the two outputs.

Each of the paired first novel optical switches is exactly the same as described in the first embodiment, for which reason duplicate descriptions to the first novel optical switches will be omitted.

As a modification to the above fifth novel optical switch, it is also possible that the fifth novel optical switch comprises a pair of the above fourth novel optical switches described in the fourth embodiment. The two fourth novel optical switches are connected to each other through a first optical transmission line **110** as a common line. If the left side one of the paired fourth novel optical switches is in input side and the right side one of the paired fourth novel optical switches is in output side, then the switching operation of the left side one of the paired fourth novel optical switches is carried out to select or switch any one of the two inputs of the fifth novel optical switch having the two inputs and the two outputs, whilst the switching operation of the right side one of the paired fourth novel optical switches is carried out to select or switch any one of the two outputs of the fifth novel optical switch having the two inputs and the two outputs, whereby the switching operations of the paired fourth novel optical switches realize the fifth novel optical switch having the two inputs and the two outputs.

Each of the paired fourth novel optical switches is exactly the same as described in the fourth embodiment, for which

reason duplicate descriptions to the fourth novel optical switches will be omitted.

In the above embodiment, the number of the wavelength multiplexing on each optical transmission line is one. Notwithstanding, 8, 16, 32, 64-wavelength multiplexing are available, wherein the batch-switching operation to the plural number wavelength multiplexing is carried out.

It is also possible to set the wavelength of the optical input signal at not only 1550 nanometers but also other wavelengths, for example, 1330 nanometers.

It is also possible to set the wavelength of the excitation light at not only 1480 nanometers or 980 nanometers but also their wavelengths provided that such wavelength is capable of exciting the impurity doped fiber. It is preferable to set the wavelength of the excitation light in consideration of both the wavelength of the optical input signal and the kind of the impurity doped fiber.

The above excitation light switch may also be replaced by an acousto-optical switch, or a quartz-based switch.

It is further possible to control an intensity of the optical output signal by controlling an optical power of the excitation light to be fed to the impurity doped fiber. It is possible to control the optical power of the excitation light to be fed to the impurity doped fiber by controlling an injection current to the excitation light source or by use of variable or fixed attenuator.

It is furthermore possible to replace the erbium doped fiber by rare earth doped fiber such as tellurium doped fiber. The length of the rare earth doped fiber and a doping concentration thereof may be set in accordance with the required specifications of the optical switch.

It is moreover possible to input the excitation light into the rare earth doped fiber in either directions or in both directions.

It is still more possible to conduct a polarization-multiplexing to different excitation lights emitted separately from plural different excitation light sources in order to input the polarization-multiplexed excitation light into the rare earth doped fiber to obtain a high gain.

It is yet more possible to set freely a ratio of optical division at the optical coupler in accordance with the various design choices.

The provisions of the smaller number of the excitation light source and the single excitation light switch permit ON-OFF switching operations of the plural gate switches by a simple structure. The above switch exhibits such a gain property as a sharp rising, for which reason there is substantially no influence due to a leaked light from the excitation light switch. This makes the switch available to switches having relatively large crosstalk levels such as a polymer type switch or LiNbO_3 switch, thereby realizing a low crosstalk and low insertion loss optical switch. In addition, the use of the impurity doped fiber serving as an optical power amplifier can obtain a gain as the optical switch.

SIXTH EMBODIMENT

A sixth embodiment according to the present invention will be described in detail with reference to FIG. 6 which is a diagram illustrative of a sixth novel optical switch having two inputs and two outputs. A structural difference of the sixth novel optical switch from the fifth novel optical switch is in providing a single or common excitation light source to a pair of modified first novel optical switches excluding individual excitation light sources described in the first embodiment.

The sixth novel optical switch comprises a pair of the first novel optical switches described in the first embodiment. The two first novel optical switches are connected to each other through a first optical transmission line **110** as a common line. The two first novel optical switches are connected are also connected to the single and common excitation light source **31** to reduce the number of the required excitation light source. If the left side one of the paired first novel optical switches is in input side and the right side one of the paired first novel optical switches is in output side, then the switching operation of the left side one of the paired first novel optical switches is carried out to select or switch any one of the two inputs of the sixth novel optical switch having the two inputs and the two outputs, whilst the switching operation of the right side one of the paired first novel optical switches is carried out to select or switch any one of the two outputs of the sixth novel optical switch having the two inputs and the two outputs, whereby the switching operations of the paired first novel optical switches realize the sixth novel optical switch having the two inputs and the two outputs.

Each of the paired first novel optical switches is the same as described in the first embodiment except for excluding the individual excitation light sources, for which reason duplicate descriptions to the first novel optical switches will be omitted.

As a modification to the above sixth novel optical switch, it is also possible that the sixth novel optical switch comprises a pair of the above fourth novel optical switches described in the fourth embodiment. The two fourth novel optical switches are connected to each other through a first optical transmission line **110** as a common line. The two first novel optical switches are connected are also connected to the single and common excitation light source **31** to reduce the number of the required excitation light source. If the left side one of the paired fourth novel optical switches is in input side and the right side one of the paired fourth novel optical switches is in output side, then the switching operation of the left side one of the paired fourth novel optical switches is carried out to select or switch any one of the two inputs of the sixth novel optical switch having the two inputs and the two outputs, whilst the switching operation of the right side one of the paired fourth novel optical switches is carried out to select or switch any one of the two outputs of the sixth novel optical switch having the two inputs and the two outputs, whereby the switching operations of the paired fourth novel optical switches realize the sixth novel optical switch having the two inputs and the two outputs.

Each of the paired fourth novel optical switches is exactly the same as described in the fourth embodiment, for which reason duplicate descriptions to the fourth novel optical switches will be omitted.

In the above embodiment, the number of the wavelength multiplexing on each optical transmission line is one. Notwithstanding, 8, 16, 32, 64-wavelength multiplexing are available, wherein the batch-switching operation to the plural number wavelength multiplexing is carried out.

It is also possible to set the wavelength of the optical input signal at not only 1550 nanometers but also other wavelengths, for example, 1330 nanometers.

It is also possible to set the wavelength of the excitation light at not only 1480 nanometers or 980 nanometers but also other wavelengths provided that such wavelengths is capable of exciting the impurity doped fiber. It is preferable to set the wavelength of the excitation light in consideration of both the wavelength of the optical input signal and the kind of the impurity doped fiber.

The above excitation light switch may also be replaced by an acousto-optical switch, or a quartz-based switch.

It is further possible to control an intensity of the optical output signal by controlling an optical power of the excitation light to be fed to the impurity doped fiber. It is possible to control the optical power of the excitation light to be fed to the impurity doped fiber by controlling an injection current to the excitation light source or by use of variable or fixed attenuator.

It is furthermore possible to replace the erbium doped fiber by rare earth doped fiber such as tellurium doped fiber. The length of the rare earth doped fiber and a doping concentration thereof may be set in accordance with the required specifications of the optical switch.

It is moreover possible to input the excitation light into the rare earth doped fiber in either directions or in both directions.

It is still more possible to conduct a polarization-multiplexing to different excitation lights emitted separately from plural different excitation light sources in order to input the polarization-multiplexed excitation light into the rare earth doped fiber to obtain a high gain.

It is yet more possible to set freely a ratio of optical division at the optical coupler in accordance with the various design choices.

The provisions of the smaller number of the excitation light source and the single excitation light switch permit ON-OFF switching operations of the plural gate switches by a simple structure. The above switch exhibits such a gain property as a sharp rising, for which reason there is substantially no influence due to a leaked light from the excitation light switch. This makes the switch available to switches having relatively large crosstalk levels such as a polymer type switch or LiNbO₃ switch, thereby realizing a low crosstalk and low insertion loss optical switch. In addition, the use of the impurity doped fiber serving as an optical power amplifier can obtain a gain as the optical switch.

SEVENTH EMBODIMENT

A seventh embodiment according to the present invention will be described in detail with reference to FIG. 7 which is a diagram illustrative of a seventh novel optical switch having four separate optical transmission lines for separately switching optical signal transmissions on the four separate optical transmission lines.

The seventh novel optical switch has first, second, third and fourth optical transmission lines **1**, **2**, **3**, and **4** on which separate optical signals are transmitted. The seventh novel optical switch also has an excitation light source **31** for emitting an excitation light. The seventh novel optical switch also has an excitation light switch **41** having a single input connected to the excitation light source **31** and four outputs. The excitation light switch **41** is capable of separately ON-OFF switching operations to transmissions of the excitation lights from the four outputs.

The first optical transmission line **1** comprises a first input side optical transmission line **211** and a first output side optical transmission line **221**, wherein the first input side optical transmission line **211** is connected through a first erbium doped fiber **11EDF** to the first input side optical transmission line **211**. A first optical coupler **21** is provided on the first input side optical transmission line **211**. The first optical coupler **21** is connected to a first output of the excitation light switch **41**. A first optical signal is transmitted

on the first input side optical transmission line **211** through the first erbium doped fiber **11EDF** to the first input side optical transmission line **211**. If the excitation light switch **41** is operated to switch ON to allow transmission of the excitation light emitted from the excitation light source **31** through the first optical coupler **21** to the first erbium doped fiber **11EDF**, then the first erbium doped fiber **11EDF** is excited to allow that the transmission of the first optical signal having been transmitted on the first input side optical transmission line **211** is transmitted through the first erbium doped fiber **11EDF** to the first output side optical transmission line **221**.

The second optical transmission line **1** comprises a second input side optical transmission line **212** and a second output side optical transmission line **222**, wherein the second input side optical transmission line **212** is connected through a second erbium doped fiber **12EDF** to the second input side optical transmission line **212**. A second optical coupler **22** is provided on the second input side optical transmission line **212**. The second optical coupler **22** is connected to a second output of the excitation light switch **41**. A second optical signal is transmitted on the second input side optical transmission line **212** through the second erbium doped fiber **12EDF** to the second input side optical transmission line **212**. If the excitation light switch **41** is operated to switch ON to allow transmission of the excitation light emitted from the excitation light source **31** through the second optical coupler **22** to the second erbium doped fiber **12EDF**, then the second erbium doped fiber **12EDF** is excited to allow that the transmission of the second optical signal having been transmitted on the second input side optical transmission line **212** is transmitted through the second erbium doped fiber **12EDF** to the second output side optical transmission line **222**.

The third optical transmission line **1** comprises a third input side optical transmission line **213** and a third output side optical transmission line **223**, wherein the third input side optical transmission line **213** is connected through a third erbium doped fiber **13EDF** to the third input side optical transmission line **213**. A third optical coupler **23** is provided on the third input side optical transmission line **213**. The third optical coupler **23** is connected to a third output of the excitation light switch **41**. A third optical signal is transmitted on the third input side optical transmission line **213** through the third erbium doped fiber **13EDF** to the third input side optical transmission line **213**. If the excitation light switch **41** is operated to switch ON to allow transmission of the excitation light emitted from the excitation light source **31** through the third optical coupler **23** to the third erbium doped fiber **13EDF**, then the third erbium doped fiber **13EDF** is excited to allow that the transmission of the third optical signal having been transmitted on the third input side optical transmission line **213** is transmitted through the third erbium doped fiber **13EDF** to the third output side optical transmission line **223**.

The fourth optical transmission line **1** comprises a fourth input side optical transmission line **214** and a fourth output side optical transmission line **224**, wherein the fourth input side optical transmission line **214** is connected through a fourth erbium doped fiber **14EDF** to the fourth input side optical transmission line **214**. A fourth optical coupler **24** is provided on the fourth input side optical transmission line **214**. The fourth optical coupler **24** is connected to a fourth output of the excitation light switch **41**. A fourth optical signal is transmitted on the fourth input side optical transmission line **214** through the fourth erbium doped fiber **14EDF** to the fourth input side optical transmission line **214**.

If the excitation light switch **41** is operated to switch ON to allow transmission of the excitation light emitted from the excitation light source **31** through the fourth optical coupler **24** to the fourth erbium doped fiber **14EDF**, then the fourth erbium doped fiber **14EDF** is excited to allow that the transmission of the fourth optical signal having been transmitted on the fourth input side optical transmission line **214** is transmitted through the fourth erbium doped fiber **14EDF** to the fourth output side optical transmission line **224**.

The excitation light switch **41** is capable of separate ON-OFF switching operations to the four outputs from which the excitation lights are outputted. If the excitation light switch **41** is operated to switch ON to the four outputs, then the excitation lights are fed through the first, second, third and fourth couplers **21**, **22**, **23** and **24** to the first, second, third and fourth erbium doped fibers **11EDF**, **12EDF**, **13EDF** and **14EDF**, whereby the first, second, third and fourth optical signals are transmitted through the first, second, third and fourth erbium doped fibers **11EDF**, **12EDF**, **13EDF** and **14EDF** to the first, second, third and fourth output side optical transmission lines **221**, **222**, **223** and **224**. If the excitation light switch **41** is operated to switch ON to the first, second and third outputs, then the excitation lights are fed through the first, second and third couplers **21**, **22** and **23** to the first, second and third erbium doped fibers **11EDF**, **12EDF** and **13EDF**, whereby the first, second and third optical signals are transmitted through the first, second and third erbium doped fibers **11EDF**, **12EDF** and **13EDF** to the first, second and third output side optical transmission lines **221**, **222** and **223**, whilst the fourth optical signal is absorbed by the fourth erbium doped fiber **14EDF**. If the excitation light switch **41** is operated to switch ON to the first and second outputs, then the excitation lights are fed through the first and second couplers **21** and **22** to the first and second erbium doped fibers **11EDF** and **12EDF**, whereby the first and second optical signals are transmitted through the first and second erbium doped fibers **11EDF** and **12EDF** to the first and second output side optical transmission lines **221** and **222**, whilst the third and fourth optical signals are absorbed by the third and fourth erbium doped fibers **13EDF** and **14EDF**. If the excitation light switch **41** is operated to switch ON to the first output, then the excitation lights are fed through the first coupler **21** to the first erbium doped fiber **11EDF**, whereby the first optical signal is transmitted through the first erbium doped fiber **11EDF** to the first output side optical transmission line **221**, whilst the second, third and fourth optical signals are absorbed by the second, third and fourth erbium doped fibers **12EDF**, **13EDF** and **14EDF**.

In the above embodiment, the number of the wavelength multiplexing on each optical transmission line is one. Notwithstanding, 8, 16, 32, 64-wavelength multiplexing are available, wherein the batch-switching operation to the plural number wavelength multiplexing is carried out.

It is also possible to set the wavelength of the optical input signal at not only 1550 nanometers but also other wavelengths, for example, 1330 nanometers.

It is also possible to set the wavelength of the excitation light at not only 1480 nanometers or 980 nanometers but also other wavelengths provided that such wavelength is capable of exciting the impurity doped fiber. It is preferable to set the wavelength of the excitation light in consideration of both the wavelength of the optical input signal and the kind of the impurity doped fiber.

The above excitation light switch may also be replaced by an acousto-optical switch, or a quartz-based switch.

It is further possible to control an intensity of the optical output signal by controlling an optical power of the excitation light to be fed to the impurity doped fiber. It is possible to control the optical power of the excitation light to be fed to the impurity doped fiber by controlling an injection current to the excitation light source or by use of variable or fixed attenuator.

It is furthermore possible to replace the erbium doped fiber by rare earth doped fiber such as tellurium doped fiber. The length of the rare earth doped fiber and a doping concentration thereof may be set in accordance with the required specifications of the optical switch.

It is moreover possible to input the excitation light into the rare earth doped fiber in either directions or in both directions.

It is still more possible to conduct a polarization-multiplexing to different excitation lights emitted separately from plural different excitation light sources in order to input the polarization-multiplexed excitation light into the rare earth doped fiber to obtain a high gain.

It is yet more possible to set freely a ratio of optical division at the optical coupler in accordance with the various design choices.

The provisions of the smaller number of the excitation light source and the single excitation light switch permit ON-OFF switching operations of the plural gate switches by a simple structure. The above switch exhibits such a gain property as a sharp rising, for which reason there is substantially no influence due to a leaked light from the excitation light switch. This makes the switch available to switches having relatively large crosstalk levels such as a polymer type switch or LiNbO₃ switch, thereby realizing a low crosstalk and low insertion loss optical switch. In addition, the use of the impurity doped fiber serving as an optical power amplifier can obtain a gain as the optical switch.

EIGHTH EMBODIMENT

An eighth embodiment according to the present invention will be described in detail with reference to FIG. 8 which is a diagram illustrative of an eighth novel optical switch having four separate optical transmission lines for separately switching optical signal transmissions on the four separate optical transmission lines. A structural difference of the eighth novel optical switch from the seventh novel optical switch is in providing double excitation light sources and an optical cross connector serving as a switch.

The eighth novel optical switch has first, second, third and fourth optical transmission lines **1**, **2**, **3**, and **4** on which separate optical signals are transmitted. The seventh novel optical switch also has first and second excitation light sources **32** and **33** for emitting excitation lights. The eighth novel optical switch also has an optical cross connector **81** serving as a switch having two inputs connected to the first and second excitation light sources **32** and **33** and four outputs. The optical cross connector **81** is capable of separate switching operations of the four outputs for each of the excitation lights emitted from the first and second excitation light sources **32** and **33**. The dual excitation lights sources **32** and **33** increases the excitation power to be fed to the individual erbium doped fibers on the first to fourth optical transmission lines **1**, **2**, **3**, and **4**.

The first optical transmission line **1** comprises a first input side optical transmission line **211** and a first output side optical transmission line **221**, wherein the first input side optical transmission line **211** is connected through a first

erbium doped fiber **11EDF** to the first input side optical transmission line **211**. A first optical coupler **21** is provided on the first input side optical transmission line **211**. The first optical coupler **21** is connected to a first output of the optical cross connector **81**. A first optical signal is transmitted on the first input side optical transmission line **211** through the first erbium doped fiber **11EDF** to the first input side optical transmission line **211**. If the optical cross connector **81** is operated to switch ON to allow transmission of the excitation light emitted from the excitation light source **31** through the first optical coupler **21** to the first erbium doped fiber **11EDF**, then the first erbium doped fiber **11EDF** is excited to allow that the transmission of the first optical signal having been transmitted on the first input side optical transmission line **211** is transmitted through the first erbium doped fiber **11EDF** to the first output side optical transmission line **221**.

The second optical transmission line **1** comprises a second input side optical transmission line **212** and a second output side optical transmission line **222**, wherein the second input side optical transmission line **212** is connected through a second erbium doped fiber **12EDF** to the second input side optical transmission line **212**. A second optical coupler **22** is provided on the second input side optical transmission line **212**. The second optical coupler **22** is connected to a second output of the optical cross connector **81**. A second optical signal is transmitted on the second input side optical transmission line **212** through the second erbium doped fiber **12EDF** to the second input side optical transmission line **212**. If the optical cross connector **81** is operated to switch ON to allow transmission of the excitation light emitted from the excitation light source **31** through the second optical coupler **22** to the second erbium doped fiber **12EDF**, then the second erbium doped fiber **12EDF** is excited to allow that the transmission of the second optical signal having been transmitted on the second input side optical transmission line **212** is transmitted through the second erbium doped fiber **12EDF** to the second output side optical transmission line **222**.

The third optical transmission line **1** comprises a third input side optical transmission line **213** and a third output side optical transmission line **223**, wherein the third input side optical transmission line **213** is connected through a third erbium doped fiber **13EDF** to the third input side optical transmission line **213**. A third optical coupler **23** is provided on the third input side optical transmission line **213**. The third optical coupler **23** is connected to a third output of the optical cross connector **81**. A third optical signal is transmitted on the third input side optical transmission line **213** through the third erbium doped fiber **13EDF** to the third input side optical transmission line **213**. If the optical cross connector **81** is operated to switch ON to allow transmission of the excitation light emitted from the excitation light source **31** through the third optical coupler **23** to the third erbium doped fiber **13EDF**, then the third erbium doped fiber **13EDF** is excited to allow that the transmission of the third optical signal having been transmitted on the third input side optical transmission line **213** is transmitted through the third erbium doped fiber **13EDF** to the third output side optical transmission line **223**.

The fourth optical transmission line **1** comprises a fourth input side optical transmission line **214** and a fourth output side optical transmission line **224**, wherein the fourth input side optical transmission line **214** is connected through a fourth erbium doped fiber **14EDF** to the fourth input side optical transmission line **214**. A fourth optical coupler **24** is provided on the fourth input side optical transmission line **214**. The fourth optical coupler **24** is connected to a fourth

output of the optical cross connector **81**. A fourth optical signal is transmitted on the fourth input side optical transmission line **214** through the fourth erbium doped fiber **14EDF** to the fourth input side optical transmission line **214**. If the optical cross connector **81** is operated to switch ON to allow transmission of the excitation light emitted from the excitation light source **31** through the fourth optical coupler **24** to the fourth erbium doped fiber **14EDF**, then the fourth erbium doped fiber **14EDF** is excited to allow that the transmission of the fourth optical signal having been transmitted on the fourth input side optical transmission line **214** is transmitted through the fourth erbium doped fiber **14EDF** to the fourth output side optical transmission line **224**.

The optical cross connector **81** is capable of separate ON-OFF switching operations to the four outputs from which the excitation lights are outputted. If the optical cross connector **81** is operated to switch ON to the four outputs, then the excitation lights are fed through the first, second, third and fourth couplers **21**, **22**, **23** and **24** to the first, second, third and fourth erbium doped fibers **11EDF**, **12EDF**, **13EDF** and **14EDF**, whereby the first, second, third and fourth optical signals are transmitted through the first, second, third and fourth erbium doped fibers **11EDF**, **12EDF**, **13EDF** and **14EDF** to the first, second, third and fourth output side optical transmission lines **221**, **222**, **223** and **224**. If the optical cross connector **81** is operated to switch ON to the first, second and third outputs, then the excitation lights are fed through the first, second and third couplers **21**, **22** and **23** to the first, second and third erbium doped fibers **11EDF**, **12EDF** and **13EDF**, whereby the first, second and third optical signals are transmitted through the first, second and third erbium doped fibers **11EDF**, **12EDF** and **13EDF** to the first, second and third output side optical transmission lines **221**, **222** and **223**, whilst the fourth optical signal is absorbed by the fourth erbium doped fiber **14EDF**. If the optical cross connector **81** is operated to switch ON to the first and second outputs, then the excitation lights are fed through the first and second couplers **21** and **22** to the first and second erbium doped fibers **11EDF** and **12EDF**, whereby the first and second optical signals are transmitted through the first and second erbium doped fibers **11EDF** and **12EDF** to the first and second output side optical transmission lines **221** and **222**, whilst the third and fourth optical signals are absorbed by the third and fourth erbium doped fibers **13EDF** and **14EDF**. If the optical cross connector **81** is operated to switch ON to the first output, then the excitation lights are fed through the first coupler **21** to the first erbium doped fiber **11EDF**, whereby the first optical signal is transmitted through the first erbium doped fiber **11EDF** to the first output side optical transmission line **221**, whilst the second, third and fourth optical signals are absorbed by the second, third and fourth erbium doped fibers **12EDF**, **13EDF** and **14EDF**.

The dual excitation light sources **32** and **33** increases the excitation power to be fed to the individual erbium doped fibers on the first to fourth optical transmission lines **1**, **2**, **3** and **4**. This means it possible to further increase the number of the separate optical transmission lines to increase the size of the optical switch.

In the above embodiment, the number of the wavelength multiplexing on each optical transmission line is one. Notwithstanding, 8, 16, 32, 64-wavelength multiplexing are available, wherein the batch-switching operation to the plural number wavelength multiplexing is carried out.

It is also possible to set the wavelength of the optical input signal at not only 1550 nanometers but also other wavelengths, for example, 1330 nanometers.

It is also possible to set the wavelength of the excitation light at not only 1480 nanometers or 980 nanometers but also other wavelengths provided that such wavelength is capable of exciting the impurity doped fiber. It is preferable to set the wavelength of the excitation light in consideration of both the wavelength of the optical input signal and the kind of the impurity doped fiber.

The above excitation light switch may also be replaced by an acousto-optical switch, or a quartz-based switch.

It is further possible to control an intensity of the optical output signal by controlling an optical power of the excitation light to be fed to the impurity doped fiber. It is possible to control the optical power of the excitation light to be fed to the impurity doped fiber by controlling an injection current to the excitation light source or by use of variable or fixed attenuator.

It is furthermore possible to replace the erbium doped fiber by rare earth doped fiber such as tellurium doped fiber. The length of the rare earth doped fiber and a doping concentration thereof may be set in accordance with the required specifications of the optical switch.

It is moreover possible to input the excitation light into the rare earth doped fiber in either directions or in both directions.

It is still more possible to conduct a polarization-multiplexing to different excitation lights emitted separately from plural different excitation light sources in order to input the polarization-multiplexed excitation light into the rare earth doped fiber to obtain a high gain.

It is yet more possible to set freely a ratio of optical division at the optical coupler in accordance with the various design choices.

The provisions of the smaller number of the excitation light source and the single excitation light switch permit ON-OFF switching operations of the plural gate switches by a simple structure. The above switch exhibits such a gain property as a sharp rising, for which reason there is substantially no influence due to a leaked light from the excitation light switch. This makes the switch available to switches having relatively large crosstalk levels such as a polymer type switch or LiNbO₃ switch, thereby realizing a low crosstalk and low insertion loss optical switch. In addition, the use of the impurity doped fiber serving as an optical power amplifier can obtain a gain as the optical switch.

NINTH EMBODIMENT

A ninth embodiment according to the present invention will be described in detail with reference to FIG. **9** which is a diagram illustrative of a ninth novel optical switch provided in a novel first optical add-drop multiplexer performing optical addition, drop and transmission of said optical signals.

The ninth novel optical switch comprises a first optical transmission line **110** for transmitting an optical signal having a wavelength of 1550 nanometers, an optical reflectivity variable mirror **50** connected to the first optical transmission line **110** for reflecting the optical signal at a controlled reflectivity, a second optical transmission line **120** connected to the optical reflectivity variable mirror **50**, and an optical transmitter **81** connected through the second optical transmission line **120** to the optical reflectivity variable mirror **50** for transmitting an optical signal having a wavelength of 1550 nanometers.

In order to form the novel first optical add-drop multiplexer, a first optical coupler **11** is provided on the first

optical transmission line **110**. Further, a third optical transmission line **121** is connected to the first optical coupler **11**. Furthermore, as optical receiver **71** is also connected with the third optical transmission line **121** so that the optical receiver **71** is also connected through the third optical transmission line **121** to the first optical coupler **11**. The optical input signal is divided by the first optical coupler **11** so that one of the divided optical input signals is transmitted through the third optical transmission line **121** to the optical receiver **71**, whilst the remaining one of the divided optical input signals is transmitted to the optical reflectivity variable mirror **50** whereby the remaining one of the divided optical input signals is reflected by the optical reflectivity variable mirror **50** at a controlled reflectivity. The optical reflectivity variable mirror **50** is capable of varying a reflectivity in the range of from 0% to 100%. If the reflectivity of the optical reflectivity variable mirror **50** is set 0%, then the optical reflectivity variable mirror **50** is in a transmission state which allows an optical signal transmission. In this case, the optical signal transmitted from the optical transmitter **81** is transmitted through the optical reflectivity variable mirror **50** to the first optical transmission line.

A signal transmission operation of the novel first optical add-drop multiplexer will subsequently be described. An optical input signal having a wavelength of 1550 nanometers is transmitted on the first optical transmission line **110** and then reflected by the optical reflectivity variable mirror **50** before the reflected optical signal is then transmitted on the first optical transmission line **110**.

A signal drop operation of the novel first optical add-drop multiplexer will subsequently be described. An optical input signal having a wavelength of 1550 nanometers is transmitted on the first optical transmission line **110** and then divided into two parts by the optical coupler **11**. One of the divided optical input signals is then transmitted through the third optical transmission line **121** to the optical receiver **71**. It is possible to set a low ratio of a first optical division for the optical receiver **71** to a second optical division for the optical reflectivity variable mirror **50**, in order to suppress an optical loss by the optical division by the optical coupler **11**.

A signal add operation of the novel first optical add-drop multiplexer will subsequently be described. The optical reflectivity variable mirror **50** is capable of varying a reflectivity in the range of from 0% to 100%. If the reflectivity of the optical reflectivity variable mirror **50** is set 0%, then the optical reflectivity variable mirror **50** is in a transmission state which allows an optical signal transmission. In this case, the optical signal transmitted from the optical transmitter **81** is transmitted through the optical reflectivity variable mirror **50** to the first optical transmission line.

The above novel first optical add-drop multiplexer does not require an optical coupler for signal adding, thereby realizing a low optical loss.

As a modification to this embodiment, it is possible to provide any one of the above first to fourth optical switches of FIGS. 1 to 4 in the first to fourth embodiments, in place of the above optical coupler **11** and the optical reflectivity variable mirror **50**.

It is possible that the input and output ports are commonly used or that the input and output ports are separated from each other by use of an optical coupler and an optical isolator or by use of a circulator.

It is also possible that the optical reflectivity variable mirror **50** may be replaced by an optical switch for switching an transmission and a reflection, or by an optical reflectivity switching mirror for switching 0% reflectivity and 100%

reflectivity, provided that if the reflectivity is 0%, then the switch is capable of transmission of the optical signal.

It is also possible to change the number of the gate arrays from eight.

The optical multiplexer, the optical demultiplexer or the optical multiplexer/demultiplexer may comprise an array waveguide grating, a wavelength router having substantially the same grating structure as the array waveguide grating, or a wavelength MUX coupler having substantially the same grating structure as the array waveguide grating.

Since insertion loss is different among the optical multiplexer, the optical demultiplexer and the optical multiplexer/demultiplexer, it is possible to use optical attenuators in individual waveguides for control of the optical power levels.

It is also possible to control a gain of the erbium doped fiber amplifier gate or control reflectivity of the reflective mirror for control of the optical power levels for every wavelengths separately.

It is furthermore possible to replace the erbium doped fiber by rare earth doped fiber such as tellurium doped fiber, or an aluminum doped fiber. The length of the rare earth doped fiber and a doping concentration thereof may be set in accordance with the required specifications of the optical switch.

The excitation light may have a wavelength of 980 nanometers in order to shorten the wavelength for a remarkable reduction in noise factor of the optical output signal. In this case, the optical switch is also free from any substantive insertion loss and a low or reduced crosstalk.

TENTH EMBODIMENT

A tenth embodiment according to the present invention will be described in detail with reference to FIG. 10 which is a diagram illustrative of a tenth novel optical switch as an optical gate switch.

The tenth novel optical switch is an optical gate switch. The tenth novel optical switch comprises an optical input signal transmission line **110** for transmitting an optical input signal, an optical output signal transmission line **120** for transmitting an optical output signal, an optical transmission line **130** connected through an optical coupler **11** to said input and output signal transmission lines **110** and **120**, an optical isolator **91** provided on said optical input signal transmission line **110** for permitting a unidirectional transmission of said optical input signal toward said optical transmission line **130**, an erbium doped fiber **41** provided on said optical transmission line **130**, a wavelength band selective optical reflecting mirror **25** provided on said optical transmission line **130**, and an excitation light source **31** connected to said wavelength band selective optical reflecting mirror **25**. The optical input signal has a wavelength of 1550 nanometers. The excitation light source **31** is capable of emitting an excitation light having a wavelength of 1480 nanometers. The wavelength band selective optical reflecting mirror **25** is capable of selecting a reflecting wavelength band of an optical signal to be reflected by the wavelength band selective optical reflecting mirror **25**.

In this case, the wavelength band selective optical reflecting mirror **25** so sets the reflecting wavelength band that the optical input signal with the wavelength of 1550 nanometers is total-reflected by the wavelength band selective optical reflecting mirror **25**, whilst the excitation light emitted from the excitation light source **31** is transmitted through the wavelength band selective optical reflecting mirror **25** to the

erbium doped fiber **41**, whereby the erbium doped fiber **41** is excited by the excitation light. The excited erbium doped fiber **41** is capable of amplifying the optical input signal. The amplified input signal is then total-reflected by the wavelength band selective optical reflecting mirror **25**. The reflected input signal is then transmitted again through the erbium doped fiber **41**, whereby the reflected signal is further amplified. The further amplified optical signal is divided by the optical coupler **11** into two parts, one of which is transmitted to the optical isolator **91**. However, the transmission of the divided optical signal is prevented by the optical isolator **91**. On the other hand, the other divided part of the optical signal is transmitted through the output signal transmission line **120**. In the above state, the above optical gate switch is in ON state.

If no excitation light is emitted from the excitation light source **31**, the erbium doped fiber **41** receives no excitation light and is unexcited, whereby the input optical signal is absorbed by the erbium doped fiber **41**. No optical signal is outputted from the output signal transmission line **120**. In the above state, the above optical gate switch is in OFF state.

The above novel optical gate switch is capable of reducing an insertion loss and also reducing the number of the required optical couplers.

It is also possible to integrate the wavelength band selective optical reflecting mirror **25** and the excitation light source **31**. FIG. **11** is a schematic view illustrative of an integration of the above novel optical gate switch. An erbium doped fiber amplifier gate array **300** has an integration of eight sets of an excitation light source **31**, a wavelength band selective optical reflecting mirror **25**, an erbium doped fiber **41**, and an optical transmission line **100**.

As a modification to this embodiment, it is possible to provide any one of the above first to fourth optical switches of FIGS. **1** to **4** in the first to fourth embodiments, in place of the above optical coupler **11** and the optical reflectivity variable mirror **50**.

It is possible that the input and output ports are commonly used or that the input and output ports are separated from each other by use of an optical coupler and an optical isolator or by use of a circulator.

It is possible to change the positions of the optical couplers provided that the functions of the optical add-drop multiplexer can be ensured.

The optical multiplexer, the optical demultiplexer or the optical multiplexer/demultiplexer may comprise an array waveguide grating, a wavelength router having substantially the same grating structure as the array waveguide grating, or a wavelength MUX coupler having substantially the same grating structure as the array waveguide grating.

Since insertion loss is different among the optical multiplexer, the optical demultiplexer and the optical multiplexer/demultiplexer, it is possible to use optical attenuators in individual waveguides for control of the optical power levels.

It is also possible to control a gain of the erbium doped fiber amplifier gate or control reflectivity of the reflective mirror for control of the optical power levels for every wavelengths separately.

It is furthermore possible to replace the erbium doped fiber by rare earth doped fiber such as tellurium doped fiber, or an aluminum doped fiber. The length of the rare earth doped fiber and a doping concentration thereof may be set in accordance with the required specifications of the optical switch.

The excitation light may have a wavelength of 980 nanometers in order to shorten the wavelength for a remarkable reduction in noise factor of the optical output signal. In this case, the optical switch is also free from any substantive insertion loss and a low or reduced crosstalk.

ELEVENTH EMBODIMENT

An eleventh embodiment according to the present invention will be described in detail with reference to FIG. **12** which is a diagram illustrative of a novel optical add-drop multiplexer using an optical gate switch of FIG. **10** for performing optical addition, drop and transmission of said optical signals.

The novel optical add-drop multiplexer using an optical gate switch comprises an optical input signal transmission line **110** for transmitting an optical input signal, an optical output signal transmission line **120** for transmitting an optical output signal, an optical transmission line **130** connected through an optical coupler **11** to said input and output signal transmission lines **110** and **120**, an optical isolator **91** provided on said optical input signal transmission line **110** for permitting a unidirectional transmission of said optical input signal toward said optical transmission line **130**, an erbium doped fiber **41** provided on said optical transmission line **130**, a wavelength band selective optical reflecting mirror **25** provided on said optical transmission line **130**, an excitation light source **31** connected to said wavelength band selective optical reflecting mirror **25**, an optical receiver **71** connected through a second optical coupler **12** to the optical transmission line **130** and positioned between the first optical coupler **11** and the erbium doped fiber **41** and an optical transmitter **81** connected through a third optical coupler **13** to the output signal optical transmission line **130**. The optical input signal has a wavelength of 1550 nanometers. The excitation light source **31** is capable of emitting an excitation light having a wavelength of 1480 nanometers. The wavelength band selective optical reflecting mirror **25** is capable of selecting a reflecting wavelength band of an optical signal to be reflected by the wavelength band selective optical reflecting mirror **25**.

In this case, the wavelength band selective optical reflecting mirror **25** so sets the reflecting wavelength band that the optical input signal with the wavelength of 1550 nanometers is total-reflected by the wavelength band selective optical reflecting mirror **25**, whilst the excitation light emitted from the excitation light source **31** is transmitted through the wavelength band selective optical reflecting mirror **25** to the erbium doped fiber **41**, whereby the erbium doped fiber **41** is excited by the excitation light. The excited erbium doped fiber **41** is capable of amplifying the optical input signal. The amplified input signal is then total-reflected by the wavelength band selective optical reflecting mirror **25**. The reflected input signal is then transmitted again through the erbium doped fiber **41**, whereby the reflected signal is further amplified. The further amplified optical signal is divided by the optical coupler **11** into two parts, one of which is transmitted to the optical isolator **91**. However, the transmission of the divided optical signal is prevented by the optical isolator **91**. On the other hand, the other divided part of the optical signal is transmitted through the output signal transmission line **120**. In the above state, the above optical gate switch is in ON state.

A signal transmission operation of the above novel optical add-drop multiplexer will subsequently be described. The excitation light is emitted from the excitation light source **31** and then supplied to the erbium doped fiber **41**, whereby the

erbium doped fiber **41** is excited. The optical input signal is transmitted through the erbium doped fiber **41** and amplified by the excited erbium doped fiber **41**. The amplified optical input signal is total-reflected by the wavelength band selective optical reflecting mirror **25**. The reflected optical signal is then transmitted again through the erbium doped fiber **41**, whereby the reflected signal is further amplified. The further amplified optical signal is divided by the first optical coupler **11** into two parts, one of which is transmitted to the optical isolator **91**. However, the transmission of the divided optical signal is prevented by the optical isolator **91**. On the other hand, the other divided part of the optical signal is transmitted through the output signal transmission line **120**.

A signal drop operation of the above novel optical add-drop multiplexer will subsequently be described. The optical input signal is divided by the second optical coupler into two parts, one of which is transmitted to the optical receiver **71**.

It is possible to set the ratio of first optical division for the optical receiver **71** to second optical division for the erbium doped fiber **41** is small in order to reduce the optical loss due to the second optical coupler **12**.

A signal add operation of the above novel optical add-drop multiplexer will subsequently be described. In this case, no excitation light is emitted from the excitation light source **31**, for which reason the erbium doped fiber **41** receives no excitation light and is unexcited, whereby the input optical signal is absorbed by the erbium doped fiber **41**. No optical signal is outputted from the output signal transmission line **120**. On the other hand, the optical transmitter **81** emits a second optical signal with a wavelength of 1550 nanometers which is then transmitted on the output signal optical transmission line **120**, whereby the second optical signal is outputted from the output signal optical transmission line **120**.

The above novel optical add-drop multiplexer is capable of reducing an insertion loss and also reducing the number of the required optical couplers.

It is also possible to integrate the wavelength band selective optical reflecting mirror **25** and the excitation light source **31**. FIG. **13** is a schematic view illustrative of an integration of the above novel optical add-drop multiplexer. An erbium doped fiber amplifier gate module **202** is provided formed on a package **201**. The erbium doped fiber amplifier gate module **202** has an erbium doped fiber amplifier gate array **300**. The erbium doped fiber amplifier gate array **300** has an integration of eight sets of an excitation light source **31**, a wavelength band selective optical reflecting mirror **25**, an erbium doped fiber **41**, and an optical transmission line **100**. The erbium doped fiber amplifier gate module **202** has an input port **110** and an output port **120** which are provided in the same side of the package **201**. This allows a high density integration of the package.

As a modification to this embodiment, it is possible to provide any one of the above first to fourth optical switches of FIGS. **1** to **4** in the first to fourth embodiments, in place of the above optical gate switch.

It is possible that the input and output ports are commonly used or that the input and output ports are separated from each other by use of an optical coupler and an optical isolator or by use of a circulator.

It is also possible that the erbium doped fibers are packaged in the same array, or that the reflective mirrors are incorporated into the erbium doped fiber amplifier gate module, or that all of the above elements are packaged onto a PLC board.

The optical multiplexer, the optical demultiplexer or the optical multiplexer/demultiplexer may comprise an array

waveguide grating, a wavelength router having substantially the same grating structure as the array waveguide grating, or a wavelength MUX coupler having substantially the same grating structure as the array waveguide grating.

Since insertion loss is different among the optical multiplexer, the optical demultiplexer and the optical multiplexer/demultiplexer, it is possible to use optical attenuators in individual waveguides for control of the optical power levels.

It is also possible to control a gain of the erbium doped fiber amplifier gate or control reflectivity of the reflective mirror for control of the optical power levels for every wavelengths separately.

It is furthermore possible to replace the erbium doped fiber by rare earth doped fiber such as tellurium doped fiber, or an aluminum doped fiber. The length of the rare earth doped fiber and a doping concentration thereof may be set in accordance with the required specifications of the optical switch.

The excitation light may have a wavelength of 980 nanometers in order to shorten the wavelength for a remarkable reduction in noise factor of the optical output signal. In this case, the optical switch is also free from any substantive insertion loss and a low or reduced crosstalk.

TWELFTH EMBODIMENT

A twelfth embodiment according to the present invention will be described in detail with reference to FIG. **14** which is a diagram illustrative of a novel wavelength-multiplexed optical add-drop multiplexer using four sets of the above novel optical add-drop multiplexer of FIG. **9**.

The novel wavelength-multiplexed optical add-drop multiplexer comprises a single optical circulator **60** connected with optical transmission lines **110**, **120** and **121**, an optical multiplexer/demultiplexer **410** connected through said optical transmission line **120** to said optical circulator **60** and first to fourth optical add-drop multiplexers **1**, **2**, **3** and **4**. The first optical add-drop multiplexer is operable for a signal having a wavelength of 1548 nanometers. The second optical add-drop multiplexer is operable for a signal having a wavelength of 1550 nanometers. The third optical add-drop multiplexer is operable for a signal having a wavelength of 1552 nanometers. The fourth optical add-drop multiplexer is operable for a signal having a wavelength of 1554 nanometers.

The optical input signal having four wavelength compositions of 1548 nanometers, 1550 nanometers, 1552 nanometers, and 1554 nanometers is transmitted from the optical transmission line **110** through the optical circulator **60** to the optical multiplexer/demultiplexer **410**, so that the optical input signal is wavelength-demultiplexed by the optical multiplexer/demultiplexer **410** whereby the optical input signal is divided into a first signal having a wavelength of 1548 nanometers, a second signal having a wavelength of 1550 nanometers, a third signal having a wavelength of 1552 nanometers, and a fourth signal having a wavelength of 1554 nanometers. The first, second, third and fourth optical signals are inputted into the first, second, third and fourth optical add-drop multiplexers **1**, **2**, **3** and **4** respectively.

The first optical add-drop multiplexer **1** comprises a first main optical transmission line **131** for transmitting the first optical signal, a first optical reflectivity variable mirror **51** provided on the first main optical transmission line **131** for reflecting the first optical signal at a controlled reflectivity, and an optical transmitter **81** with an end of the first main optical transmission line **131**, a first subordinate optical

transmission line **135** connected through a first optical coupler **11** to the first main optical transmission line, and a first optical receiver **71** connected with said first subordinate optical transmission line **135**. The first optical input signal is divided by the first optical coupler **11** so that one of the divided first optical input signal is transmitted through the first subordinate optical transmission line **135** to the optical receiver **71**, whilst the remaining one of the divided first optical input signal is transmitted to the optical reflectivity variable mirror **51** whereby the remaining one of the divided first optical input signal is reflected by the first optical reflectivity variable mirror **51** at a controlled reflectivity. The first optical reflectivity variable mirror **51** is capable of varying a reflectivity in the range of from 0% to 100%. If the reflectivity of the first optical reflectivity variable mirror **51** is set 0%, then the first optical reflectivity variable mirror **51** is in a transmission state which allows an optical signal transmission. In this case, the first optical signal transmitted from the first optical transmitter **81** is transmitted through the first optical reflectivity variable mirror **51** to the first main optical transmission line **131**.

A signal transmission operation of the first optical add-drop multiplexer will subsequently be described. The first optical input signal is transmitted on the first main optical transmission line **131** and then reflected by the first optical reflectivity variable mirror **51** before the reflected optical signal is then transmitted on the first main optical transmission line **131**.

A signal drop operation of the first optical add-drop multiplexer will subsequently be described. The first optical input signal is transmitted on the first main optical transmission line **131** and then divided into two parts by the first optical coupler **11**. One of the divided first optical input signals is then transmitted through the first subordinate optical transmission line **135** to the optical receiver **71**.

A signal add operation of the first optical add-drop multiplexer will subsequently be described. If the reflectivity of the first optical reflectivity variable mirror **51** is set 0%, then the first optical reflectivity variable mirror **51** is in a transmission state which allows an optical signal transmission. In this case, a first substitute optical signal transmitted from the optical transmitter **81** is transmitted through the first optical reflectivity variable mirror **51** to the first main optical transmission line **131**.

The second optical add-drop multiplexer **2** comprises a second main optical transmission line **132** for transmitting the second optical signal, a second optical reflectivity variable mirror **52** provided on the second main optical transmission line **132** for reflecting the second optical signal at a controlled reflectivity, and an optical transmitter **82** with an end of the second main optical transmission line **132**, a second subordinate optical transmission line **136** connected through a second optical coupler **12** to the second main optical transmission line, and a second optical receiver **72** connected with said second subordinate optical transmission line **136**. The second optical input signal is divided by the second optical coupler **12** so that one of the divided second optical input signal is transmitted through the second subordinate optical transmission line **136** to the optical receiver **72**, whilst the remaining one of the divided second optical input signal is transmitted to the optical reflectivity variable mirror **52** whereby the remaining one of the divided second optical input signal is reflected by the second optical reflectivity variable mirror **52** at a controlled reflectivity. The second optical reflectivity variable mirror **52** is capable of varying a reflectivity in the range of from 0% to 100%. If the reflectivity of the second optical reflectivity variable mirror

52 is set 0%, then the second optical reflectivity variable mirror **52** is in a transmission state which allows an optical signal transmission. In this case, the second optical signal transmitted from the second optical transmitter **82** is transmitted through the second optical reflectivity variable mirror **52** to the second main optical transmission line **132**.

A signal transmission operation of the second optical add-drop multiplexer will subsequently be described. The second optical input signal is transmitted on the second main optical transmission line **132** and then reflected by the second optical reflectivity variable mirror **52** before the reflected optical signal is then transmitted on the second main optical transmission line **132**.

A signal drop operation of the second optical add-drop multiplexer will subsequently be described. The second optical input signal is transmitted on the second main optical transmission line **132** and then divided into two parts by the second optical coupler **12**. One of the divided second optical input signals is then transmitted through the second subordinate optical transmission line **136** to the optical receiver **72**.

A signal add operation of the second optical add-drop multiplexer will subsequently be described. If the reflectivity of the second optical reflectivity variable mirror **52** is set 0%, then the second optical reflectivity variable mirror **52** is in a transmission state which allows an optical signal transmission. In this case, a second substitute optical signal transmitted from the optical transmitter **82** is transmitted through the second optical reflectivity variable mirror **52** to the second main optical transmission line **132**.

The third optical add-drop multiplexer **3** comprises a third main optical transmission line **133** for transmitting the third optical signal, a third optical reflectivity variable mirror **53** provided on the third main optical transmission line **133** for reflecting the third optical signal at a controlled reflectivity, and an optical transmitter **83** with an end of the third main optical transmission line **133**, a third subordinate optical transmission line **137** connected through a third optical coupler **13** to the third main optical transmission line, and a third optical receiver **73** connected with said third subordinate optical transmission line **137**. The third optical input signal is divided by the third optical coupler **13** so that one of the divided third optical input signal is transmitted through the third subordinate optical transmission line **137** to the optical receiver **73**, whilst the remaining one of the divided third optical input signal is transmitted to the optical reflectivity variable mirror **53** whereby the remaining one of the divided third optical input signal is reflected by the third optical reflectivity variable mirror **53** at a controlled reflectivity. The third optical reflectivity variable mirror **53** is capable of varying a reflectivity in the range of from 0% to 100%. If the reflectivity of the third optical reflectivity variable mirror **53** is set 0%, then the third optical reflectivity variable mirror **53** is in a transmission state which allows an optical signal transmission. In this case, the third optical signal transmitted from the third optical transmitter **83** is transmitted through the third optical reflectivity variable mirror **53** to the third main optical transmission line **133**.

A signal transmission operation of the third optical add-drop multiplexer will subsequently be described. The third optical input signal is transmitted on the third main optical transmission line **133** and then reflected by the third optical reflectivity variable mirror **53** before the reflected optical signal is then transmitted on the third main optical transmission line **133**.

A signal drop operation of the third optical add-drop multiplexer will subsequently be described. The third optical input signal is transmitted on the third main optical transmission line 133 and then divided into two parts by the third optical coupler 13. One of the divided third optical input signals is then transmitted through the third subordinate optical transmission line 137 to the optical receiver 73.

A signal add operation of the third optical add-drop multiplexer will subsequently be described. If the reflectivity of the third optical reflectivity variable mirror 53 is set 0%, then the third optical reflectivity variable mirror 53 is in a transmission state which allows an optical signal transmission. In this case, a third substitute optical signal transmitted from the optical transmitter 83 is transmitted through the third optical reflectivity variable mirror 53 to the third main optical transmission line 133.

The fourth optical add-drop multiplexer 4 comprises a fourth main optical transmission line 134 for transmitting the fourth optical signal, a fourth optical reflectivity variable mirror 54 provided on the fourth main optical transmission line 134 for reflecting the fourth optical signal at a controlled reflectivity, and an optical transmitter 84 with an end of the fourth main optical transmission line 134, a fourth subordinate optical transmission line 138 connected through a fourth optical coupler 14 to the fourth main optical transmission line, and a fourth optical receiver 74 connected with said fourth subordinate optical transmission line 138. The fourth optical input signal is divided by the fourth optical coupler 14 so that one of the divided fourth optical input signal is transmitted through the fourth subordinate optical transmission line 138 to the optical receiver 74, whilst the remaining one of the divided fourth optical input signal is transmitted to the optical reflectivity variable mirror 54 whereby the remaining one of the divided fourth optical input signal is reflected by the fourth optical reflectivity variable mirror 54 at a controlled reflectivity. The fourth optical reflectivity variable mirror 54 is capable of varying a reflectivity in the range of from 0% to 100%. If the reflectivity of the fourth optical reflectivity variable mirror 54 is set 0%, then the fourth optical reflectivity variable mirror 54 is in a transmission state which allows an optical signal transmission. In this case, the fourth optical signal transmitted from the fourth optical transmitter 84 is transmitted through the fourth optical reflectivity variable mirror 54 to the fourth main optical transmission line 134.

A signal transmission operation of the fourth optical add-drop multiplexer will subsequently be described. The fourth optical input signal is transmitted on the fourth main optical transmission line 134 and then reflected by the fourth optical reflectivity variable mirror 54 before the reflected optical signal is then transmitted on the fourth main optical transmission line 134.

A signal drop operation of the fourth optical add-drop multiplexer will subsequently be described. The fourth optical input signal is transmitted on the fourth main optical transmission line 134 and then divided into two parts by the fourth optical coupler 14. One of the divided fourth optical input signals is then transmitted through the fourth subordinate optical transmission line 138 to the optical receiver 74.

A signal add operation of the fourth optical add-drop multiplexer will subsequently be described. If the reflectivity of the fourth optical reflectivity variable mirror 54 is set 0%, then the fourth optical reflectivity variable mirror 54 is in a transmission state which allows an optical signal transmission. In this case, a fourth substitute optical signal

transmitted from the optical transmitter 84 is transmitted through the fourth optical reflectivity variable mirror 54 to the fourth main optical transmission line 134.

First, second, third and fourth output signals are multiplexed by the optical multiplexer/demultiplexer 410 to form a single output signal which is then transmitted through the circulator 60 to the optical transmission line 121.

The above novel optical add-drop multiplexers do require no optical coupler for signal adding, thereby realizing a low optical loss.

As a modification to this embodiment, it is possible to provide any one of the above first to fourth optical switches of FIGS. 1 to 4 in the first to fourth embodiments, in place of the above optical couplers and the optical reflectivity variable mirrors.

It is possible that the input and output ports are commonly used or that the input and output ports are separated from each other by use of an optical coupler and an optical isolator or by use of a circulator.

It is also possible to change the number of the wavelength-multiplexing from four into, for example, eight, sixteen, thirty two or sixty four.

It is also possible to change the wavelength of the optical signals and also change a bit rate or a signal rate to 2.5 Gbps, 5 Gbps, 100 Gbps or set a bit-rate free.

The optical multiplexer, the optical demultiplexer or the optical multiplexer/demultiplexer may comprise an array waveguide grating, a wavelength router having substantially the same grating structure as the array waveguide grating, or a wavelength MUX coupler having substantially the same grating structure as the array waveguide grating.

Since insertion loss is different among the optical multiplexer, the optical demultiplexer and the optical multiplexer/demultiplexer, it is possible to use optical attenuators in individual waveguides for control of the optical power levels.

It is also possible to control a gain of the erbium doped fiber amplifier gate or control reflectivity of the reflective mirror for control of the optical power levels for every wavelengths separately.

It is furthermore possible to replace the erbium doped fiber by rare earth doped fiber such as tellurium doped fiber, or an aluminum doped fiber. The length of the rare earth doped fiber and a doping concentration thereof may be set in accordance with the required specifications of the optical switch.

The excitation light may have a wavelength of 980 nanometers in order to shorten the wavelength for a remarkable reduction in noise factor of the optical output signal. In this case, the optical switch is also free from any substantive insertion loss and a low or reduced crosstalk.

THIRTEENTH EMBODIMENT

A thirteenth embodiment according to the present invention will be described in detail with reference to FIG. 15 which is a diagram illustrative of a novel wavelength-multiplexed optical add-drop multiplexer using four sets of the above novel optical add-drop multiplexer of FIG. 12.

The novel wavelength-multiplexed optical add-drop multiplexer comprises a single optical circulator 60 connected with optical transmission lines 110, 120 and 121, an optical multiplexer/demultiplexer 410 connected through said optical transmission line 120 to said optical circulator 60 and first to fourth optical add-drop multiplexers 1, 2, 3 and 4. The first optical add-drop multiplexer is operable for a signal

having a wavelength of 1548 nanometers. The second optical add-drop multiplexer is operable for a signal having a wavelength of 1550 nanometers. The third optical add-drop multiplexer is operable for a signal having a wavelength of 1552 nanometers. The fourth optical add-drop multiplexer is operable for a signal having a wavelength of 1554 nanometers.

The optical input signal having four wavelength compositions of 1548 nanometers, 1550 nanometers, 1552 nanometers, and 1554 nanometers is transmitted from the optical transmission line **110** through the optical circulator **60** to the optical multiplexer/demultiplexer **410**, so that the optical input signal is wavelength-demultiplexed by the optical multiplexer/demultiplexer **410** whereby the optical input signal is divided into a first signal having a wavelength of 1548 nanometers, a second signal having a wavelength of 1550 nanometers, a third signal having a wavelength of 1552 nanometers, and a fourth signal having a wavelength of 1554 nanometers. The first, second, third and fourth optical signals are inputted into the first, second, third and fourth optical add-drop multiplexers **1**, **2**, **3** and **4** respectively.

The first optical add-drop multiplexer **1** comprises a first optical transmission line **131** for transmitting an optical input signal, a first erbium doped fiber **41** provided on said first optical transmission line **131**, a first wavelength band selective optical reflecting mirror **25** provided on said first optical transmission line **131**, a first excitation light source **31** connected to said first wavelength band selective optical reflecting mirror **25**, a first optical receiver **71** connected through a first receiver side optical coupler **11** to the first optical transmission line **131** and an optical transmitter **81** connected through a first transmitter side optical coupler **15** to the first signal optical transmission line **131**. The excitation light source **31** is capable of emitting an excitation light having a different wavelength from the first optical signal. The first wavelength band selective optical reflecting mirror **25** is capable of selecting a reflecting wavelength band of the first optical signal to be reflected by the first wavelength band selective optical reflecting mirror **25**. The first optical input signal is total-reflected by the first wavelength band selective optical reflecting mirror **25**, whilst the first excitation light emitted from the first excitation light source **31** is transmitted through the first wavelength band selective optical reflecting mirror **25** to the first erbium doped fiber **41**, whereby the first erbium doped fiber **41** is excited by the first excitation light. The first excited erbium doped fiber **41** is capable of amplifying the first optical input signal. The amplified input signal is then total-reflected by the first wavelength band selective optical reflecting mirror **25**. The reflected input signal is then transmitted again through the first erbium doped fiber **41**, whereby the reflected signal is further amplified. The further amplified optical signal is transmitted through the first output signal transmission line **131**.

A signal transmission operation of the above first optical add-drop multiplexer will subsequently be described. The first excitation light is emitted from the first excitation light source **31** and then supplied to the first erbium doped fiber **41**, whereby the first erbium doped fiber **41** is excited. The optical input signal is transmitted through the first erbium doped fiber **41** and amplified by the excited first erbium doped fiber **41**. The amplified optical input signal is total-reflected by the first wavelength band selective optical reflecting mirror **25**. The reflected optical signal is then transmitted again through the first erbium doped fiber **41**, whereby the reflected signal is further amplified. The further amplified optical signal is transmitted through the first signal

transmission line **131** to the optical multiplexer/demultiplexer **410**.

A signal drop operation of the above first optical add-drop multiplexer will subsequently be described. The first optical input signal is divided by the first receiver side optical coupler **11** into two parts, one of which is transmitted to the first optical receiver **71**.

A signal add operation of the above first optical add-drop multiplexer will subsequently be described. In this case, no excitation light is emitted from the first excitation light source **31**, for which reason the first erbium doped fiber **41** receives no excitation light and is unexcited, whereby the first input optical signal is absorbed by the first erbium doped fiber **41**. No optical signal is outputted from the first signal transmission line **131**. On the other hand, the first optical transmitter **81** emits a first substitute optical signal which is then transmitted through the first transmitter side optical coupler **15** on the first optical transmission line **131**, whereby the first substitute optical signal is outputted from the first optical transmission line **131**.

The second optical add-drop multiplexer **2** comprises a second optical transmission line **132** for transmitting an optical input signal, a second erbium doped fiber **42** provided on said second optical transmission line **132**, a second wavelength band selective optical reflecting mirror **26** provided on said second optical transmission line **132**, a second excitation light source **32** connected to said second wavelength band selective optical reflecting mirror **26**, a second optical receiver **72** connected through a second receiver side optical coupler **12** to the second optical transmission line **132** and an optical transmitter **82** connected through a second transmitter side optical coupler **16** to the second signal optical transmission line **132**. The excitation light source **32** is capable of emitting an excitation light having a different wavelength from the second optical signal. The second wavelength band selective optical reflecting mirror **26** is capable of selecting a reflecting wavelength band of the second optical signal to be reflected by the second wavelength band selective optical reflecting mirror **26**. The second optical input signal is total-reflected by the second wavelength band selective optical reflecting mirror **26**, whilst the second excitation light emitted from the second excitation light source **32** is transmitted through the second wavelength band selective optical reflecting mirror **26** to the second erbium doped fiber **42**, whereby the second erbium doped fiber **42** is excited by the second excitation light. The second excited erbium doped fiber **42** is capable of amplifying the second optical input signal. The amplified input signal is then total-reflected by the second wavelength band selective optical reflecting mirror **26**. The reflected input signal is then transmitted again through the second erbium doped fiber **42**, whereby the reflected signal is further amplified. The further amplified optical signal is transmitted through the second output signal transmission line **132**.

A signal transmission operation of the above second optical add-drop multiplexer will subsequently be described. The second excitation light is emitted from the second excitation light source **32** and then supplied to the second erbium doped fiber **42**, whereby the second erbium doped fiber **42** is excited. The optical input signal is transmitted through the second erbium doped fiber **42** and amplified by the excited second erbium doped fiber **42**. The amplified optical input signal is total-reflected by the second wavelength band selective optical reflecting mirror **26**. The reflected optical signal is then transmitted again through the second erbium doped fiber **42**, whereby the reflected signal is further amplified. The further amplified optical signal is

transmitted through the second signal transmission line 132 to the optical multiplexer/demultiplexer 420.

A signal drop operation of the above second optical add-drop multiplexer will subsequently be described. The second optical input signal is divided by the second receiver side optical coupler 12 into two parts, one of which is transmitted to the second optical receiver 72.

A signal add operation of the above second optical add-drop multiplexer will subsequently be described. In this case, no excitation light is emitted from the second excitation light source 32, for which reason the second erbium doped fiber 42 receives no excitation light and is unexcited, whereby the second input optical signal is absorbed by the second erbium doped fiber 42. No optical signal is outputted from the second signal transmission line 132. On the other hand, the second optical transmitter 82 emits a second substitute optical signal which is then transmitted through the second transmitter side optical coupler 16 on the second optical transmission line 132, whereby the second substitute optical signal is outputted from the second optical transmission line 132.

The third optical add-drop multiplexer 3 comprises a third optical transmission line 133 for transmitting an optical input signal, a third erbium doped fiber 43 provided on said third optical transmission line 133, a third wavelength band selective optical reflecting mirror 27 provided on said third optical transmission line 133, a third excitation light source 33 connected to said third wavelength band selective optical reflecting mirror 27, a third optical receiver 73 connected through a third receiver side optical coupler 13 to the third optical transmission line 133 and an optical transmitter 83 connected through a third transmitter side optical coupler 17 to the third signal optical transmission line 133. The excitation light source 33 is capable of emitting an excitation light having a different wavelength from the third optical signal. The third wavelength band selective optical reflecting mirror 27 is capable of selecting a reflecting wavelength band of the third optical signal to be reflected by the third wavelength band selective optical reflecting mirror 27. The third optical input signal is total-reflected by the third wavelength band selective optical reflecting mirror 27, whilst the third excitation light emitted from the third excitation light source 33 is transmitted through the third wavelength band selective optical reflecting mirror 27 to the third erbium doped fiber 43, whereby the third erbium doped fiber 43 is excited by the third excitation light. The third excited erbium doped fiber 43 is capable of amplifying the third optical input signal. The amplified input signal is then total-reflected by the third wavelength band selective optical reflecting mirror 27. The reflected input signal is then transmitted again through the third erbium doped fiber 43, whereby the reflected signal is further amplified. The further amplified optical signal is transmitted through the third output signal transmission line 133.

A signal transmission operation of the above third optical add-drop multiplexer will subsequently be described. The third excitation light is emitted from the third excitation light source 33 and then supplied to the third erbium doped fiber 43, whereby the third erbium doped fiber 43 is excited. The optical input signal is transmitted through the third erbium doped fiber 43 and amplified by the excited third erbium doped fiber 43. The amplified optical input signal is total-reflected by the third wavelength band selective optical reflecting mirror 27. The reflected optical signal is then transmitted again through the third erbium doped fiber 43, whereby the reflected signal is further amplified. The further amplified optical signal is transmitted through the third

signal transmission line 133 to the optical multiplexer/demultiplexer 430.

A signal drop operation of the above third optical add-drop multiplexer will subsequently be described. The third optical input signal is divided by the third receiver side optical coupler 13 into two parts, one of which is transmitted to the third optical receiver 73.

A signal add operation of the above third optical add-drop multiplexer will subsequently be described. In this case, no excitation light is emitted from the third excitation light source 33, for which reason the third erbium doped fiber 43 receives no excitation light and is unexcited, whereby the third input optical signal is absorbed by the third erbium doped fiber 43. No optical signal is outputted from the third signal transmission line 133. On the other hand, the third optical transmitter 83 emits a third substitute optical signal which is then transmitted through the third transmitter side optical coupler 17 on the third optical transmission line 133, whereby the third substitute optical signal is outputted from the third optical transmission line 133.

The fourth optical add-drop multiplexer 4 comprises a fourth optical transmission line 134 for transmitting an optical input signal, a fourth erbium doped fiber 44 provided on said fourth optical transmission line 134, a fourth wavelength band selective optical reflecting mirror 28 provided on said fourth optical transmission line 134, a fourth excitation light source 34 connected to said fourth wavelength band selective optical reflecting mirror 28, a fourth optical receiver 74 connected through a fourth receiver side optical coupler 14 to the fourth optical transmission line 134 and an optical transmitter 84 connected through a fourth transmitter side optical coupler 18 to the fourth signal optical transmission line 134. The excitation light source 34 is capable of emitting an excitation light having a different wavelength from the fourth optical signal. The fourth wavelength band selective optical reflecting mirror 28 is capable of selecting a reflecting wavelength band of the fourth optical signal to be reflected by the fourth wavelength band selective optical reflecting mirror 28. The fourth optical input signal is total-reflected by the fourth wavelength band selective optical reflecting mirror 28, whilst the fourth excitation light emitted from the fourth excitation light source 34 is transmitted through the fourth wavelength band selective optical reflecting mirror 28 to the fourth erbium doped fiber 44, whereby the fourth erbium doped fiber 44 is excited by the fourth excitation light. The fourth excited erbium doped fiber 44 is capable of amplifying the fourth optical input signal. The amplified input signal is then total-reflected by the fourth wavelength band selective optical reflecting mirror 28. The reflected input signal is then transmitted again through the fourth erbium doped fiber 44, whereby the reflected signal is further amplified. The further amplified optical signal is transmitted through the fourth output signal transmission line 134.

A signal transmission operation of the above fourth optical add-drop multiplexer will subsequently be described. The fourth excitation light is emitted from the fourth excitation light source 34 and then supplied to the fourth erbium doped fiber 44, whereby the fourth erbium doped fiber 44 is excited. The optical input signal is transmitted through the fourth erbium doped fiber 44 and amplified by the excited fourth erbium doped fiber 44. The amplified optical input signal is total-reflected by the fourth wavelength band selective optical reflecting mirror 28. The reflected optical signal is then transmitted again through the fourth erbium doped fiber 44, whereby the reflected signal is further amplified. The further amplified optical signal is transmitted

through the fourth signal transmission line **134** to the optical multiplexer/demultiplexer **440**.

A signal drop operation of the above fourth optical add-drop multiplexer will subsequently be described. The fourth optical input signal is divided by the fourth receiver side optical coupler **14** into two parts, one of which is transmitted to the fourth optical receiver **74**.

A signal add operation of the above fourth optical add-drop multiplexer will subsequently be described. In this case, no excitation light is emitted from the fourth excitation light source **34**, for which reason the fourth erbium doped fiber **44** receives no excitation light and is unexcited, whereby the fourth input optical signal is absorbed by the fourth erbium doped fiber **44**. No optical signal is outputted from the fourth signal transmission line **134**. On the other hand, the fourth optical transmitter **84** emits a fourth substitute optical signal which is then transmitted through the fourth transmitter side optical coupler **18** on the fourth optical transmission line **134**, whereby the fourth substitute optical signal is outputted from the fourth optical transmission line **134**.

First, second, third and fourth output signals are multiplexed by the optical multiplexer/demultiplexer **410** to form a single output signal which is then transmitted through the circulator **60** to the optical transmission line **121**.

The above novel optical add-drop multiplexer is capable of reducing an insertion loss and also reducing the number of the required optical couplers.

It is also possible to integrate the wavelength band selective optical reflecting mirrors and the excitation light sources.

It is possible that the input and output ports are commonly used or that the input and output ports are separated from each other by use of an optical coupler and an optical isolator or by use of a circulator.

It is also possible to change the number of the wavelength-multiplexing from four into, for example, eight, sixteen, thirty two or sixty four.

It is also possible to change the wavelength of the optical signals and also change a bit rate or a signal rate to 2.5 Gbps, 10Gbps, 100Gbps or set a bit-rate free.

The optical multiplexer, the optical demultiplexer or the optical multiplexer/demultiplexer may comprise an array waveguide grating, a wavelength router having substantially the same grating structure as the array waveguide grating, or a wavelength MUX coupler having substantially the same grating structure as the array waveguide grating.

Since insertion loss is different among the optical multiplexer, the optical demultiplexer and the optical multiplexer/demultiplexer, it is possible to use optical attenuators in individuals waveguides for control of the optical power levels.

It is also possible to control reflectivity of the reflective mirror for control of the optical power levels for every wavelengths separately.

It is furthermore possible to replace the erbium doped fiber by rare earth doped fiber such as tellurium doped fiber, or an aluminum doped fiber. The length of the rare earth doped fiber and a doping concentration thereof may be set in accordance with the required specifications of the optical switch.

The excitation light may have a wavelength of 980 nanometers in order to shorten the wavelength for a remarkable reduction in noise factor of the optical output signal. In this case, the optical switch is also free from any substantive insertion loss and a low or reduced crosstalk.

FOURTEENTH EMBODIMENT

A fourteenth embodiment according to the present invention will be described in detail with reference to FIG. **16** which is a diagram illustrative of a novel wavelength-multiplexed optical add-drop multiplexer having four looped optical transmission paths.

The novel wavelength-multiplexed optical add-drop multiplexer comprises an optical multiplexer/demultiplexer **410** having an input port **110** and an output port **120**, and first to fourth optical transmission lines **131**, **132**, **133** and **134** connected to the optical multiplexer/demultiplexer **410**. The first optical transmission line **131** is provided for transmitting a signal having a wavelength of 1530 nanometers. The second optical transmission line **132** is provided for transmitting a signal having a wavelength of 1540 nanometers. The third optical transmission line **133** is provided for transmitting a signal having a wavelength of 1550 nanometers. The fourth optical transmission line is provided for transmitting a signal having a wavelength of 1560 nanometers.

the optical input signal having four wavelength compositions of 1530 nanometers, 1540 nanometers, 1550 nanometers, and 1560 nanometers is transmitted from the optical transmission line **110** to the optical multiplexer/demultiplexer **410**, so that the optical input signal is wavelength-demultiplexed by the optical multiplexer/demultiplexer **410** whereby the optical input signal is divided into a first signal having a wavelength of 1530 nanometers, a second signal having a wavelength of 1540 nanometers, a third signal having a wavelength of 1550 nanometers, and a fourth signal having a wavelength of 1560 nanometers. The first, second, third and fourth optical signals are inputted into the first, second, third and fourth optical transmission lines **131**, **132**, **133** and **134** respectively.

The first optical transmission line **131** has a first receiver side optical coupler **31** which is connected to a first optical receiver **71**, and a first transmitter **84**. The first optical transmission line **131** also has first optical multiplexer/demultiplexer **151**.

FIG. **17** is a diagram illustrative of the first optical multiplexer/demultiplexer **151** used in the wavelength-multiplexed optical add-drop multiplexer of FIG. **16**. The first optical multiplexer/multiplexer **151** performs a wavelength demultiplexing so as to divide the first optical input signal into two different wavelength optical signals having 1.55 micrometers and 1.54 micrometers which are outputted from two output ports. The first optical multiplexer/demultiplexer **151** is used in place of the optical coupler so that the wavelength different two optical signals has a total optical power which is higher than the first optical signal, thereby to solve a problem with remarkable optical power loss caused when the signal is transmitted through a plurality of optical couplers.

The second optical transmission line **132** has a second receiver side optical coupler **32** which is connected to a second optical receiver **72**, and a second transmitter side optical coupler **41** which is connected to a second optical transmitter **81**. The second optical transmission line **132** also has a second optical multiplexer/demultiplexer **152**. The first optical multiplexer/demultiplexer **151** is also connected through a series connection of a first optical amplifier **51** and a first isolator **91** to the second optical multiplexer/demultiplexer **152**. One of the wavelength-demultiplexed optical signals is transmitted from the first optical multiplexer/demultiplexer **151** through the first optical

amplifier **51** and the first isolator **91** to the second optical multiplexer/demultiplexer **152**.

The second optical multiplexer/demultiplexer **152** performs a wavelength demultiplexing so as to divide the first optical input signal into two different wavelength optical signals which are outputted from two outputs ports. The second optical multiplexer/demultiplexer **152** is used in place of the optical coupler so that the wavelength different two optical signals has a total optical power which is higher than the second optical signal, thereby to solve a problem with remarkable optical power loss caused when the signal is transmitted through a plurality of optical couplers.

The third optical transmission line **133** has a third receiver side optical coupler **33** which is connected to a third optical receiver **73**, and a third transmitter **82**. The third optical transmission line **133** also has a third optical multiplexer/demultiplexer **153**. The second optical multiplexer/demultiplexer **152** is also connected through a series connection of a second optical amplifier **52** and a second isolator **92** to the third optical multiplexer/demultiplexer **153**. One of the wavelength-demultiplexed optical signals is transmitted from the second optical multiplexer/demultiplexer **152** through the second optical amplifier **52** and the second isolator **92** to the third optical multiplexer/demultiplexer **153**.

The third optical multiplexer/demultiplexer **153** performs a wavelength demultiplexing so as to divide the first optical input signal into two different wavelength optical signals which are outputted from two output ports. The third optical multiplexer/demultiplexer **153** is used in place of the optical coupler so that the wavelength different two optical signals has a total optical power which is higher than the third optical signal, thereby to solve a problem with remarkable optical power loss caused when the signal is transmitted through a plurality of optical couplers.

The fourth optical transmission line **134** has a fourth receiver side optical coupler **34** which is connected to a fourth optical receiver **73**, and a fourth transmitter side optical coupler **43** which is connected to a fourth optical transmitter **82**. The fourth optical transmission line **134** also has a fourth optical multiplexer/demultiplexer **154**. The third optical multiplexer/demultiplexer **153** is also connected through a series connection of a third optical amplifier **52** and a third isolator **93** to the fourth optical multiplexer/demultiplexer **154**. One of the wavelength-demultiplexed optical signals is transmitted from the third optical multiplexer/demultiplexer **153** through the third optical amplifier **52** and the third isolator **93** to the fourth optical multiplexer/demultiplexer **154**.

The fourth optical multiplexer/demultiplexer **154** performs a wavelength demultiplexing so as to divide the first optical input signal into two different wavelength optical signals which are outputted from two output ports. The fourth optical multiplexer/demultiplexer **154** is used in place of the optical coupler so that the wavelength different two optical signals has a total optical power which is higher than the fourth optical signal, thereby to solve a problem with remarkable optical power loss caused when the signal is transmitted through a plurality of optical couplers.

The fourth optical multiplexer/demultiplexer **154** is also connected through a series connection of a fifth optical amplifier **54** and a fifth optical attenuator **94** to the first optical multiplexer/demultiplexer **151**.

The above wavelength-multiplexed optical add-drop multiplexer performs signal transmission operation, signal drop operation and signal add operation.

The signal transmission operation of the wavelength-multiplexed optical add-drop multiplexer will be described. The first input signal is transmitted through the first optical multiplexer/demultiplexer **151** to the first optical amplifier **51**, whereby the signal is amplified by the first optical amplifier **51**. The amplified signal is then transmitted through the first optical isolator **91** to the second optical multiplexer/demultiplexer **152**. Since the second optical multiplexer/demultiplexer **152** has a multiplexing function, the amplified signal is transmitted through the second optical transmission line **132** to the optical multiplexer/demultiplexer **141**, whereby the signal is multiplexed with other signal to output an output signal from the output port **120**. The second input signal is transmitted through the second optical multiplexer/demultiplexer **152** to the second optical amplifier **52**, whereby the signal is amplified by the second optical amplifier **52**. The amplified signal is then transmitted through the second optical isolator **92** to the third optical multiplexer/demultiplexer **153**. Since the third optical multiplexer/demultiplexer **153** has a multiplexing function, the amplified signal is transmitted through the third optical transmission line **133** to the optical multiplexer/demultiplexer **141**, whereby the signal is multiplexed with other signal to output an output signal from the output port **120**. The third input signal is transmitted through the third optical multiplexer/demultiplexer **153** to the third optical amplifier **53**, whereby the signal is amplified by the third optical amplifier **53**. The amplified signal is then transmitted through the third optical isolator **93** to the fourth optical multiplexer/demultiplexer **154** has a multiplexing function, the amplified signal is transmitted through the fourth optical transmission line **134** to the optical multiplexer/demultiplexer **141**, whereby the signal is multiplexed with other signal to output an output signal from the output port **120**. The fourth input signal is transmitted through the fourth optical multiplexer/demultiplexer **154** to the fourth optical amplifier **54**, whereby the signal is amplified by the fourth optical amplifier **54**. The amplified signal is then transmitted through the fourth optical isolator **94** to the first optical multiplexer/demultiplexer **151**. Since the first optical multiplexer/demultiplexer **151** has a multiplexing function, the amplified signal is transmitted through the first optical transmission line **131** to the optical multiplexer/demultiplexer **141**, whereby the signal is multiplexed with other signal to output an output signal from the output port **120**.

The signal drop operation of the wavelength-multiplexed optical add-drop multiplexer will be described. The first input signal is transmitted from the first optical transmission line **131** through the first receiver side optical coupler **31** into the first optical receiver **71**. The second input signal is transmitted from the second optical transmission line **132** through the second receiver side optical coupler **32** into the second optical receiver **72**. The third input signal is transmitted from the third optical transmission line **133** through the third receiver side optical coupler **33** into the third optical receiver **73**. The fourth input signal is transmitted from the fourth optical transmission line **134** through the fourth receiver side optical coupler **34** into the fourth optical receiver **74**.

The signal add operation of the wavelength-multiplexed optical add-drop multiplexer will be described. The first optical amplifier **51** turns OFF, whereby the transmission of the first optical signal through the first optical transmission line **131** and the first optical amplifier **51**, whereby not signal is transmitted through the second optical multiplexer/demultiplexer **152** to the second optical transmission line

132. On the other hand, a first substitute signal is transmitted from the second optical transmitter **81** so that the first substitute signal is then transmitted through the second optical transmission line **132** to the optical multiplexer/demultiplexer **141**, whereby the signal is multiplexed with other signal to output an output signal from the output port **120**. The second optical amplifier **52** turns OFF, whereby the transmission of the second optical signal through the second optical transmission line **132** and the second optical multiplexer/demultiplexer **152** is discontinued by the second optical amplifier **52**, whereby no signal is transmitted through the third optical multiplexer/demultiplexer **153** to the third optical transmission line **133**. On the other hand, a second substitute signal is transmitted from the third optical transmitter **82** so that the second substitute signal is then transmitted through the third optical transmission line **133** to the optical multiplexer/demultiplexer **141**, whereby the signal is multiplexed with other signal to output an output signal from the output port **120**. The third optical amplifier **53** turns OFF, whereby the transmission of the third optical signal through the third optical transmission line **133** and the third optical multiplexer/demultiplexer **153** is discontinued by the third optical amplifier **53**, whereby no signal is transmitted through the fourth optical multiplexer/demultiplexer **154** to the fourth optical transmission line **134**. On the other hand, a third substitute signal is transmitted from the fourth optical transmitter **83** so that the third substitute signal is then transmitted through the fourth optical transmission line **134** to the optical multiplexer/demultiplexer **141**, whereby the signal is multiplexed with other signal to output an output signal from the output port **120**. The fourth optical amplifier **54** turns OFF, whereby the transmission of the fourth optical signal through the fourth optical transmission line **134** and the fourth optical multiplexer/demultiplexer **154** is discontinued by the fourth optical amplifier **54**, whereby no signal is transmitted through the first optical multiplexer/demultiplexer **151** to the first optical transmission line **131**. On the other hand, a fourth substitute signal is transmitted from the first optical transmitter **84** so that the fourth substitute signal is then transmitted through the first optical transmission line **131** to the optical multiplexer/demultiplexer **141**, whereby the signal is multiplexed with other signal to output an output signal from the output port **120**.

The use of the optical wavelength-multiplexer/demultiplexer to serve as the same function as the optical coupler reduces the optical power loss by not less than 5 dB as compared to the 1:1 optical coupler.

FIFTEENTH EMBODIMENT

A fifteenth embodiment according to the present invention will be described in detail with reference to FIG. **18** which is a diagram illustrative of a novel wavelength-multiplexed optical add-drop multiplexer having four looped optical transmission paths.

The novel wavelength-multiplexed optical add-drop multiplexer comprises an optical multiplexer/demultiplexer **410** having an input port **110** and an output port **120**, and first to fourth optical transmission lines **131**, **132**, **133** and **134** connected to the optical multiplexer/demultiplexer **410**. The first optical transmission line **131** is provided for transmitting a signal having a wavelength of 1530 nanometers. The second optical transmission line **132** is provided for transmitting a signal having a wavelength of 1540 nanometers. The third optical transmission line **133** is provided for transmitting a signal having a wavelength of 1550 nanometers. The fourth optical transmission line is provided for transmitting a signal having a wavelength of 1560 nanometers.

The optical input signal having four wavelength compositions of 1530 nanometers, 1540 nanometers, 1550 nanometers, and 1560 nanometers is transmitted from the optical transmission line **110** to the optical multiplexer/demultiplexer **410**, so that the optical input signal is wavelength-demultiplexed by the optical multiplexer/demultiplexer **410** whereby the optical input signal is divided into a first signal having a wavelength of 1530 nanometers, a second signal having a wavelength of 1540 nanometers, a third signal having a wavelength of 1550 nanometers, and a fourth signal having a wavelength of 1560 nanometers. The first, second, third and fourth optical signals are inputted into the first, second, third and fourth optical transmission lines **131**, **132**, **133** and **134** respectively.

The first optical transmission line **131** has a first receiver side optical coupler **31** which is connected to a first optical receiver **71**, and a first transmitter side optical coupler **44** which is connected to a first optical transmitter **84**. The first optical transmission line **131** also has a first optical circulator **61**.

The second optical transmission line **132** has a second receiver side optical coupler **32** which is connected to a second optical receiver **72**, and a second transmitter side optical coupler **41** which is connected to a second optical transmitter **81**. The second optical transmission line **132** also has a second optical circulator **62**. The first optical circulator **61** is also connected through a first optical amplifier **51** to the second optical circulator **62**. One of the wavelength-demultiplexed optical signals is transmitted from the first optical circulator **61** through the first optical amplifier **51** to the second optical circulator **62**.

The third optical transmission line **133** has third receiver side optical coupler **33** which is connected to a third optical receiver **73**, and a third transmitter **82**. The third optical transmission line **133** also has a third optical circulator **63**. The second optical circulator **62** is also connected through a second optical amplifier **52** to the third optical circulator **63**. One of the wavelength-demultiplexed optical signals is transmitted from the second optical circulator **62** through the second optical amplifier **52** to the third optical circulator **63**.

The fourth optical transmission line **134** has a fourth receiver side optical coupler **34** which is connected to a fourth optical receiver **73**, and a fourth transmitter side optical coupler **43** which is connected to a fourth optical transmitter **82**. The fourth optical transmission line **134** also has a fourth optical circulator **64**. The third optical circulator **63** is also connected through a third optical amplifier **52** to the fourth optical circulator **64**. One of the wavelength-demultiplexed optical signals is transmitted from the third optical circulator **63** through the third optical amplifier **52** to the fourth optical circulator **64**.

The fourth optical circulator **64** is also connected through a series connection of a fifth optical amplifier **54** and a fifth optical attenuator **94** to the first optical circulator **61**.

The above wavelength-multiplexed optical add-drop multiplexer performs signal transmission operation, signal drop operation and a signal add operation.

The signal transmission operation of the wavelength-multiplexed optical add-drop multiplexer will be described. The first input signal is transmitted through the first optical circulator **61** to the first optical amplifier **51**, whereby the signal is amplified by the first optical amplifier **51**. The amplified signal is then transmitted to the second optical circulator **62**. The amplified signal is transmitted through the second optical transmission line **132** to the optical

multiplexer/demultiplexer **141**, whereby the signal is multiplexed with other signal to output an output signal from the output port **120**. The second input signal is transmitted through the second optical circulator **62** to the second optical amplifier **52**, whereby the signal is amplified by the second optical amplifier **52**. The amplified signal is then transmitted to the third optical circulator **63**. The amplified signal is transmitted through the third optical transmission line **133** to the optical multiplexer/demultiplexer **141**, whereby the signal is multiplexed with other signal to output an output signal from the output port **120**. The third input signal is transmitted through the third optical circulator **63** to the third optical amplifier **53**, whereby the signal is amplified by the third optical amplifier **53**. The amplified signal is then transmitted to the fourth optical circulator **64**. The amplified signal is transmitted through the fourth optical transmission line **134** to the optical multiplexer/demultiplexer **141**, whereby the signal is multiplexed with other signal to output an output signal from the output port **120**. The fourth input signal is transmitted through the fourth optical circulator **64** to the fourth optical amplifier **54**, whereby the signal is amplified by the fourth optical amplifier **54**. The amplified signal is then transmitted to the first optical circulator **61**. The amplified signal is transmitted through the first optical transmission line **131** to the optical multiplexer/demultiplexer **141**, whereby the signal is multiplexed with other signal to output an output signal from the output port **120**.

The signal drop operation of the wavelength-multiplexed optical add-drop multiplexer will be described. The first input signal is transmitted from the first optical transmission line **131** through the first receiver side optical coupler **31** into the first optical receiver **71**. The second input signal is transmitted from the second optical transmission line **132** through the second receiver side optical coupler **32** into the second optical receiver **72**. The third input signal is transmitted from the third optical transmission line **133** through the third receiver side optical coupler **33** into the third optical receiver **73**. The fourth input signal is transmitted from the fourth optical transmission line **134** through the fourth receiver side optical coupler **34** into the fourth optical receiver **74**.

The signal add operation of the wavelength-multiplexed optical add-drop multiplexer will be described. The first optical amplifier **51** turns OFF, whereby the transmission of the first optical signal through the first optical transmission line **131** and the first optical circulator **61** is discontinued by the first optical amplifier **51**, whereby no signal is transmitted through the second optical circulator **62** to the second optical transmission line **132**. On the other hand, a first substitute signal is transmitted from the second optical transmitter **81** so that the first substitute signal is then transmitted through the second optical transmission line **312** to the optical multiplexer/demultiplexer **141**, whereby the signal is multiplexed with other signal to output an output signal from the output port **120**. The second optical amplifier **52** turns OFF, whereby the transmission of the second optical signal through the second optical transmission line **132** and the second optical circulator **62** is discontinued by the second optical amplifier **52**, whereby no signal is transmitted through the third optical circulator **63** to the third optical transmission line **133**. On the other hand, a second substitute signal is transmitted from the third optical transmitter **82** so that the second substitute signal is then transmitted through the third optical transmission line **133** to the optical multiplexer/demultiplexer **141**, whereby the signal is multiplexed with other signal to output an output signal from

the output port **120**. The third optical amplifier **53** turns OFF, whereby the transmission of the third optical signal through the third optical transmission line **133** and the third optical circulator **63** is discontinued by the third optical amplifier **53**, whereby no signal is transmitted through the fourth optical circulator **64** to the fourth optical transmission line **134**. On the other hand, a third substitute signal is transmitted from the fourth optical transmitter **83** so that the third substitute signal is then transmitted through the fourth optical transmission line **134** to the optical multiplexer/demultiplexer **141**, whereby the signal is multiplexed with other signal to output an output signal from the output port **120**. The fourth optical amplifier **54** turns OFF, whereby the transmission of the fourth optical signal through the fourth optical transmission line **134** and the fourth optical circulator **64** is discontinued by the fourth optical amplifier **54**, whereby no signal is transmitted through the first optical circulator **61** to the first optical transmission line from the first optical transmitter **84** so that the fourth substitute signal is then transmitted through the first optical transmission line **131** to the optical multiplexer/demultiplexer **141**, whereby the signal is multiplexed with other signal to output an output signal from the output port **120**.

The use of the optical isolator to serve as the same function as the optical coupler reduces the optical power loss by not less than 5 dB as compared to the 1:1 optical coupler.

SIXTEENTH EMBODIMENT

A sixteenth embodiment according to the present invention will be described in detail with reference to FIG. **9** which is a diagram illustrative of a novel wavelength-multiplexed optical amplifier having four looped optical transmission paths.

The novel wavelength-multiplexed optical amplifier is structurally different from the above wavelength-multiplexed optical add-drop multiplexer of FIG. **16** in view of no provision of optical receivers and optical transmitters.

The novel wavelength-multiplexer optical amplifier comprises an optical multiplexer/demultiplexer **410** having an input port **110** and an output port **120**, and first to fourth optical transmission lines **131**, **132**, **133** and **134** connected to the optical multiplexer/demultiplexer **410**. The first optical transmission line **131** is provided for transmitting a signal having a wavelength of 1530 nanometers. The second optical transmission line **132** is provided for transmitting a signal having a wavelength of 1540 nanometers. The third optical transmission line **133** is provided for transmitting a signal having a wavelength of 1550 nanometers. The fourth optical transmission line is provided for transmitting a signal having a wavelength of 1560 nanometers.

The optical input signal having four wavelength compositions of 1530 nanometers, 1540 nanometers, 1550 nanometers, and 1560 nanometers is transmitted from the optical transmission line **110** to the optical multiplexer/demultiplexer **410**, so that the optical input signal is wavelength-multiplexed by the optical multiplexer/demultiplexer **410** whereby the optical input signal is divided into a first signal having a wavelength of 1530 nanometers, a second signal having a wavelength of 1540 nanometers, a third signal having a wavelength of 1550 nanometers, and a fourth signal having a wavelength of 1560 nanometers. The first, second, third and fourth optical signals are inputted into the first, second, third and fourth optical transmission lines **131**, **132**, **133** and **134** respectively.

The first optical transmission line **131** has a first optical multiplexer/demultiplexer **151**.

The first optical multiplexer/demultiplexer **151** performs a wavelength demultiplexing so as to divide the first optical input signal into two different wavelength optical signals having 1.55 micrometers and 1.54 micrometers which are outputted from two output ports. The first optical multiplexer/demultiplexer **151** is used in place of the optical coupler so that the wavelength different two optical signals has a total optical power which is higher than the first optical signal, thereby to solve a problem with remarkable optical power loss caused when the signal is transmitted through a plurality of optical couplers.

The second optical transmission line **132** has a second optical multiplexer/demultiplexer **152**. The first optical multiplexer/demultiplexer **151** is also connected through a series connection of a first optical amplifier **55** and a first isolator **91** to the second optical multiplexer/demultiplexer **152**. One of the wavelength-demultiplexer **151** through the first optical amplifier **55** and the first isolator **91** to the second optical multiplexer/demultiplexer **152**.

The second optical multiplexer/demultiplexer **152** performs a wavelength demultiplexing so as to divide the first optical input signal into two different wavelength optical signals which are outputted from two output ports. The second optical multiplexer/demultiplexer **152** is used in place of the optical coupler so that the wavelength different two optical signals has a total optical power which is higher than the second optical signal, thereby to solve a problem with remarkable optical power loss caused when the signal is transmitted through a plurality of optical couplers.

The third optical transmission line **133** has a third optical multiplexer/demultiplexer **153**. The second optical multiplexer/demultiplexer **152** is also connected through a series connection of a second optical amplifier **56** and a second isolator **92** to the third optical multiplexer/demultiplexer **153**. One of the wavelength-demultiplexed optical signals is transmitted from the second optical multiplexer/demultiplexer **152** through the second optical amplifier **56** and the second isolator **92** to the third optical multiplexer/demultiplexer **153**.

The third optical multiplexer/demultiplexer **153** performs a wavelength demultiplexing so as to divide the first optical input signal into two different wavelength optical signals which are outputted from two output ports. The third optical multiplexer/demultiplexer **153** is used in place of the optical coupler so that the wavelength different two optical signals has a total optical power which is higher than the third optical signal, thereby to solve a problem with remarkable optical power loss caused when the signal is transmitted through a plurality of optical couplers.

The fourth optical transmission line **134** has a fourth optical multiplexer/demultiplexer **154**. The third optical multiplexer/demultiplexer **153** is also connected through a series connection of a third optical amplifier **56** and a third isolator **93** to the fourth optical multiplexer/demultiplexer **154**. One of the wavelength-demultiplexed optical signals is transmitted from the third optical multiplexer/demultiplexer **153** through the third optical amplifier **56** and the third isolator **93** to the fourth optical multiplexer/demultiplexer **154**.

The fourth optical multiplexer/demultiplexer **154** performs a wavelength demultiplexing so as to divide the first optical input signal into two different wavelength optical signals which are outputted from two output ports. The fourth optical multiplexer/demultiplexer **154** is used in place of the optical coupler so that the wavelength different two optical signals has a total optical power which is higher than

the fourth optical signal, thereby to solve a problem with remarkable optical power loss caused when the signal is transmitted through a plurality of optical couplers.

The fourth optical multiplexer/demultiplexer **154** is also connected through a series connection of a fifth optical amplifier **58** and a fifth optical attenuator **94** to the first optical multiplexer/demultiplexer **151**.

The above wavelength-multiplexed optical amplifier performs signal transmission operation.

The signal transmission operation of the wavelength-multiplexed optical amplifier will be described. The first input signal is transmitted through the first optical multiplexer/demultiplexer **151** to the first optical amplifier **55**, whereby the signal is amplified by the first optical amplifier **55**. The amplified signal is then transmitted through the first optical isolator **91** to the second optical multiplexer/demultiplexer **152**. Since the second optical multiplexer/demultiplexer **152** has a multiplexing function, the amplified signal is transmitted through the second optical transmission line **132** to the optical multiplexer/demultiplexer **141**, whereby the signal is multiplexed with other signal to output an output signal from the output port **120**. The second input signal is transmitted through the second optical multiplexer/demultiplexer **152** to the second optical amplifier **56**, whereby the signal is amplified by the second optical amplifier **56**. The amplified signal is then transmitted through the second optical isolator **92** to the third optical multiplexer/demultiplexer **153** has a multiplexing function, the amplified signal is transmitted through the third optical transmission line **133** to the optical multiplexer/demultiplexer **141**, whereby the signal is multiplexed with other signal to output an output signal from the output port **120**. The third input signal is transmitted through the third optical multiplexer/demultiplexer **153** to the third optical amplifier **57**, whereby the signal is amplified by the third optical amplifier **57**. The amplified signal is then transmitted through the third optical isolator **93** to the fourth optical multiplexer/demultiplexer **154**. Since the fourth optical multiplexer/demultiplexer **154** has a multiplexing function, the amplified signal is transmitted through the fourth optical transmission line **134** to the optical multiplexer/demultiplexer **141**, whereby the signal is multiplexed with other signal to output an output signal from the output port **120**. The fourth input signal is transmitted through the fourth optical multiplexer/demultiplexer **154** to the fourth optical amplifier **58**, whereby the signal is amplified by the fourth optical amplifier **58**. The amplified signal is then transmitted through the fourth optical isolator **94** to the first optical multiplexer/demultiplexer **151**. Since the first optical multiplexer/demultiplexer **151** has a multiplexing function, the amplified signal is transmitted through the first optical transmission line **131** to the optical multiplexer/demultiplexer **141**, whereby the signal is multiplexed with other signal to output an output signal from the output port **120**.

The use of the optical wavelength-multiplexer/demultiplexer to serve as the same function as the optical coupler reduces the optical power loss by not less than 5 dB as compared to the 1:1 optical coupler.

SEVENTEENTH EMBODIMENT

A seventeenth embodiment according to the present invention will be described in detail with reference to FIG. **20** which is a diagram illustrative of a novel wavelength-multiplexed optical equalizer having four looped optical transmission paths.

The novel wavelength-multiplexed optical equalizer is structurally different from the above wavelength-multiplexed optical amplifier of FIG. 19 in view of further provision of an optical amplifier 55 on an input port and replacing optical amplifiers by attenuators 181, 182, 183 and 184.

The novel wavelength-multiplexed optical equalizer comprises an optical multiplexer/demultiplexer 410 having an input port 110 and an output port 120, and first to fourth optical transmission lines 131, 132, 133 and 134 connected to the optical multiplexer/demultiplexer 410. The first optical transmission line 131 is provided for transmitting a signal having a wavelength of 1530 nanometers. The second optical transmission line 132 is provided for transmitting a signal having a wavelength of 1540 nanometers. The third optical transmission line 133 is provided for transmitting a signal having a wavelength of 1550 nanometers. The fourth optical transmission line is provided for transmitting a signal having a wavelength of 1560 nanometers.

The optical input signal having four wavelength compositions of 1530 nanometers, 1540 nanometers, 1550 nanometers, and 1560 nanometers is transmitted from the optical transmission line 110 to the optical multiplexer/demultiplexer 410, so that the optical input signal is wavelength-demultiplexed by the optical multiplexer/demultiplexer 410 whereby the optical input signal is divided into a first signal having a wavelength of 1530 nanometers, a second signal having a wavelength of 1540 nanometers, a third signal having a wavelength of 1550 nanometers, and a fourth signal having a wavelength of 1560 nanometers. The first, second, third and fourth optical signals are inputted into the first, second, third and fourth optical transmission lines 131, 132, 133 and 134 respectively.

The first optical transmission line 131 has a first optical multiplexer/demultiplexer 151.

The first optical multiplexer/demultiplexer 151 performs a wavelength demultiplexing so as to divide the first optical input signal into two different wavelength optical signals having 1.55 micrometers and 1.54 micrometers which are outputted from two output ports. The first optical multiplexer/demultiplexer 151 is used in place of the optical coupler so that the wavelength different two optical signals has a total optical power which is higher than the first optical signal, thereby to solve a problem with remarkable optical power loss caused when the signal is transmitted through a plurality of optical couplers.

The second optical transmission line 132 has a second optical multiplexer/demultiplexer 152. The first optical multiplexer/demultiplexer 151 is also connected through a series connection of a first optical attenuator 181 and a first isolator 91 to the second optical multiplexer/demultiplexer 152. One of the wavelength-demultiplexed optical signals is transmitted from the first optical multiplexer/demultiplexer 1151 through the first optical attenuator 181 and the first isolator 91 to the second optical multiplexer/demultiplexer 152.

The second optical multiplexer/demultiplexer 152 performs a wavelength demultiplexing so as to divide the first optical input signal into two different wavelength optical signals which are outputted from two output ports. The second optical multiplexer/demultiplexer 152 is used in place of the optical coupler so that the wavelength different two optical signals has a total optical power which is higher than the second optical signal, thereby to solve a problem with remarkable optical power loss caused when the signal is transmitted through a plurality of optical couplers.

The third optical transmission line 133 has a third optical multiplexer/demultiplexer 153. The second optical multiplexer/demultiplexer 152 is also connected through a series connection of a second optical attenuator 182 and a second isolator 92 to the third optical multiplexer/demultiplexer 153. One of the wavelength-demultiplexed optical signals is transmitted from the second optical multiplexer/demultiplexer 152 through the second optical attenuator 182 and the second isolator 92 to the third optical multiplexer/demultiplexer 153.

The third optical multiplexer/demultiplexer 153 performs a wavelength demultiplexing so as to divide the first optical input signal into two different wavelength optical signals which are outputted from two output ports. The third optical multiplexer/demultiplexer 153 is used in place of the optical coupler so that the wavelength different two optical signals has a total optical power which is higher than the third optical signal, thereby to solve a problem with remarkable optical power loss caused when the signal is transmitted through a plurality of optical couplers.

The first optical transmission line 134 has a fourth optical multiplexer/demultiplexer 154. The third optical multiplexer/demultiplexer 153 is also connected through a series connection of a third optical attenuator 182 and a third isolator 93 to the fourth optical multiplexer/demultiplexer 154. One of the wavelength-demultiplexed optical signals is transmitted from the third optical multiplexer/demultiplexer 153 through the third optical attenuator 182 and the third isolator 93 to the fourth optical multiplexer/demultiplexer 154.

The fourth optical multiplexer/demultiplexer 154 performs a wavelength demultiplexing so as to divide the first optical input signal into two different wavelength optical signals which are outputted from two output ports. The fourth optical multiplexer/demultiplexer 154 is used in place of the optical coupler so that the wavelength different two optical signals has a total optical power which is higher than the fourth optical signal, thereby to solve a problem with remarkable optical power loss caused when the signal is transmitted through a plurality of optical couplers.

The fourth optical multiplexer/demultiplexer 154 is also connected through a series connection of a fifth optical attenuator 184 and a fifth optical attenuator 94 to the first optical multiplexer/demultiplexer 151.

The above wavelength-multiplexed optical equalizer performs signal transmission operation.

The signal transmission operation of the wavelength-multiplexed optical equalizer will be described. The first input signal is transmitted through the first optical multiplexer/demultiplexer 151 to the first optical attenuator 181, whereby the signal is attenuated by the first optical attenuator 181. The attenuated signal is then transmitted through the first optical isolator 91 to the second optical multiplexer/demultiplexer 152. Since the second optical multiplexer/demultiplexer 152 has a multiplexing function, the attenuated signal is transmitted through the second optical transmission line 132 to the optical multiplexer/demultiplexer 152 to the second optical attenuator 182. The attenuated signal is then transmitted through the second optical isolator 92 to the third optical multiplexer/demultiplexer 153. Since the third optical multiplexer/demultiplexer 153 has a multiplexing function, the attenuated signal is transmitted through the third optical transmission line 133 to the optical multiplexer/demultiplexer 141, whereby the signal is multiplexed with other signal to output an output signal from the output port

120. The third input signal is transmitted through the third optical multiplexer/demultiplexer 153 to the third optical attenuator 183, whereby the signal is attenuated by the third optical attenuator 183. The attenuated signal is then transmitted through the third optical isolator 93 to the fourth optical multiplexer/demultiplexer 154. Since the fourth optical multiplexer/demultiplexer 154 has a multiplexing function, the attenuated signal is transmitted through the fourth optical transmission line 134 to the optical multiplexer/demultiplexer 141, whereby the signal is multiplexed with other signal to output an output signal from the output port 120. The fourth input signal is transmitted through the fourth optical multiplexer/demultiplexer 154 to the fourth optical attenuator 184, whereby the signal is attenuated by the fourth optical attenuator 184. The attenuated signal is then transmitted through the fourth optical isolator 94 to the first optical multiplexer/demultiplexer 151. Since the first optical multiplexer/demultiplexer 151 has a multiplexing function, the attenuated signal is transmitted through the first output signal from the output port 120.

The use of the optical wavelength-multiplexer/demultiplexer to serve as the same function as the optical coupler reduces the optical power loss by not less than 5 dB as compared to the 1:1 optical coupler.

EIGHTEENTH EMBODIMENT

An eighteenth embodiment according to the present invention will be described in detail with reference to FIG. 21 which is a diagram illustrative of a novel optical gate switch utilizing optical wavelength multiplexer/demultiplexer and an erbium doped fiber.

An optical transmission line 121 is provided for transmitting an optical signal having a wavelength of 1550 nanometers. The optical transmission line 121 has first and second optical wavelength multiplexer/demultiplexer 155 and 156, and an erbium doped fiber 141 between the first and second optical wavelength multiplexer/demultiplexer 155 and 156. An excitation light source 161 is provided for emitting an excitation light having a wavelength of 1480 nanometers. The excitation light source 161 is connected through a first subordinate optical transmission line 122 to the first wavelength multiplexer/demultiplexer 155. A second subordinate optical transmission line 123 extends from the second optical wavelength multiplexer/demultiplexer 156. The excitation light is emitted from the excitation light source 161 and then transmitted through the first subordinate optical transmission line 122 to the first wavelength multiplexer/demultiplexer 155. The excitation light is multiplexed with the optical signal by the first wavelength multiplexer/demultiplexer 155 and further fed to the erbium doped fiber 141 to excite the erbium doped fiber 141, whereby the optical signal transmitted on the optical transmission line 121 is amplified by the erbium doped fiber 141 and then amplified signal is transmitted to the second wavelength multiplexer/demultiplexer 156. The excitation of the erbium doped fiber 141 is caused by absorption of the 1480 nanometers wavelength composition of the multiplexed signal into the erbium doped fiber 141. The 1480 nanometers wavelength composition of the multiplexed signal may partially be unabsorbed into the erbium doped fiber 141. The multiplexed signal is then transmitted to the second wavelength multiplexer/demultiplexer 156 so that the remaining 1480 nanometers wavelength composition is demultiplexed from the 1550 nanometers wavelength composition by the second wavelength multiplexer/demultiplexer 156, whereby the remaining 1480 nanometers wavelength composition is transmitted through the second

subordinate optical transmission line 123 whilst the 1550 nanometers wavelength composition is then transmitted through the optical transmission line 121.

The excitation light has a large intensity for causing an excitation of the erbium doped fiber 141. A majority part of the excitation light is absorbed into the erbium doped fiber 141 for excitation of the erbium doped fiber 141, whilst a minority part of the excitation light is not absorbed into the erbium doped fiber 141 and then transmitted through the erbium doped fiber 141. This transmitted excitation light remains to have the large intensity. Actually, this remaining excitation light is multiplexed with the optical signal. However, the second wavelength multiplexer/demultiplexer 156 is operated for demultiplexing the signal into the optical signal having the wavelength of 1550 nanometers and the remaining excitation light having the wavelength of 1480 nanometers, whereby the second wavelength multiplexer/demultiplexer 156 sends the optical signal having the wavelength of 1550 nanometers on the optical transmission line 121 and also sends the remaining excitation light having the wavelength of 1480 nanometers on the second subordinate optical transmission line 123 to avoid the transmission of the remaining excitation light on the optical transmission line 121. The optical transmission line 121 may be connected to an optical multiplexer/demultiplexer. However, the optical multiplexer/demultiplexer receives no excitation light, whereby the optical multiplexer/demultiplexer is free from any damage by the excitation light. If the optical transmission line 121 is connected to other optical device, then the optical device receives no excitation light, whereby the optical device is free from any damage by the excitation light.

NINETEENTH EMBODIMENT

A nineteenth embodiment according to the present invention will be described in detail with reference to FIG. 22 which is a diagram illustrative of a novel optical gate switch utilizing optical wavelength multiplexer/demultiplexer and an erbium doped fiber.

An optical transmission line 121 is provided for transmitting an optical signal having a wavelength of 1550 nanometers. The optical transmission line 121 has first and second optical wavelength multiplexer/demultiplexers 157 and 158, and an erbium doped fiber 141 between the first and second optical wavelength multiplexer/demultiplexers 157 and 158. An excitation light source 163 is provided for emitting an excitation light having a wavelength of 1480 nanometers. The excitation light source 163 is connected through a first subordinate optical transmission line 122 to the first wavelength multiplexer/demultiplexer 157. A second subordinate optical transmission line 123 extends from the second optical wavelength multiplexer/demultiplexer 158. The second subordinate optical transmission line 123 has an optical reflective mirror 25 and a monitor 200. The optical reflecting mirror may comprise a wavelength band selective optical reflecting mirror which is capable of selecting a wavelength band of a light to be reflected. The excitation light is emitted from the excitation light source 163 and then transmitted through the first subordinate optical transmission line 122 to the first wavelength multiplexer/demultiplexer 157. The excitation light is multiplexed with the optical signal by the first wavelength multiplexer/demultiplexer 157 and further fed to the erbium doped fiber 141 to excite the erbium doped fiber 141, whereby the optical signal transmitted on the optical transmission line 121 is amplified by the erbium doped fiber 141 and then amplified signal is transmitted to the second wavelength

multiplexer/demultiplexer **158**. The excitation of the erbium doped fiber **141** is caused by absorption of the 1480 nanometers wavelength composition of the multiplexed signal into the erbium doped fiber **141**. The 1480 nanometers wavelength composition of the multiplexed signal may partially be unabsorbed into the erbium doped fiber **141**. The multiplexed signal is then transmitted to the second wavelength multiplexer/demultiplexer **158** so that the remaining 1480 nanometers wavelength composition is demultiplexed from the 1550 nanometers wavelength composition by the second wavelength multiplexer/demultiplexer **158**, whereby the remaining 1480 nanometers wavelength composition is transmitted through the second subordinate optical transmission line **123** whilst the 1550 nanometers wavelength composition is then transmitted through the optical transmission line **121**. The remaining 1480 nanometers wavelength composition corresponds to a transmitted minority part of the excitation light having a large intensity, for which reason the transmitted minority part of the excitation light having a large intensity is transmitted through the second subordinate optical transmission line to the wavelength-band optical reflecting mirror **25**. The transmitted minority part of the excitation light is thus reflected by the wavelength-band optical reflecting mirror **25** and then transmitted through the second wavelength multiplexer/demultiplexer **158** to the erbium doped fiber **141** again whereby the transmitted minority part of the excitation light is further used to excite the erbium doped fiber **141**. As a result, the efficiency of the excitation of the erbium doped fiber **141** is high.

The excitation light has a large intensity for causing an excitation of the erbium doped fiber **141**. A majority part of the excitation light is absorbed into the erbium doped fiber **141** for excitation of the erbium doped fiber **141**, whilst a minority part of the excitation light is not absorbed into the erbium doped fiber **141** and then transmitted through the erbium doped fiber **141**. This transmitted excitation light remains to have the large intensity. Actually, this remaining excitation light is multiplexed with the optical signal. However, the second wavelength multiplexer/demultiplexer **158** is operated for demultiplexing the signal into the optical signal having the wavelength of 1550 nanometers and the remaining excitation light having the wavelength of 1480 nanometers, whereby the second wavelength multiplexer/demultiplexer **158** sends the optical signal having the wavelength of 1550 nanometers on the optical transmission line **121** and also sends the remaining excitation light having the wavelength of 1480 nanometers on the second subordinate optical transmission line **123** to avoid the transmission of the remaining excitation light on the optical transmission line **121**. The optical transmission line **121** may be connected to an optical multiplexer/demultiplexer. However, the optical multiplexer/demultiplexer receives no excitation light, whereby the optical multiplexer/demultiplexer is free from any damage by the excitation light. If the optical transmission line **121** is connected to other optical device, then the optical device receives no excitation light, whereby the optical device is free from any damage by the excitation light.

Further, a slight amount of the optical signal is transmitted through the second wavelength multiplexer/demultiplexer **158** to the second subordinate optical wavelength line **123**. Since the wavelength-band optical reflecting mirror **25** sets the reflecting wavelength band at 1448 nanometers for reflecting the excitation light component, then the slight amount of the optical signal having the wavelength of 1550 nanometers is transmitted through the wavelength-band optical reflecting mirror **25** to the monitor **200**. The monitor

200 monitors the intensity of the leaked optical signal for controlling optical power levels and device damage monitoring.

TWENTIETH EMBODIMENT

A twentieth embodiment according to the present invention will be described in detail with reference to FIG. **23** which is a diagram illustrative of a novel optical gate switch utilizing optical wavelength multiplexer/demultiplexer and an erbium doped fiber.

An optical transmission line **121** is provided for transmitting an optical signal having a wavelength of 1550 nanometers. The optical transmission line **121** has first and second optical wavelength multiplexer/demultiplexers **157** and **158**, and an erbium doped fiber **141** between the first and second optical wavelength multiplexer/demultiplexers **157** and **158**. A first excitation light source **163** is provided for emitting a first excitation light having a wavelength of 1480 nanometers. The first excitation light source **163** is connected through a first subordinate optical transmission line **22** to the first wavelength multiplexer/demultiplexer **157**. A second excitation light source **164** is provided for emitting a second excitation light having a wavelength of 1480 nanometers. The second excitation light source **164** is connected through a second subordinate optical transmission line **123** to the second wavelength multiplexer/demultiplexer **158**. The first excitation light is emitted from the excitation light source **163** and then transmitted through the first subordinate optical transmission line **122** to the first wavelength multiplexer/demultiplexer **157**. The first excitation light is multiplexed with the optical signal by the first wavelength multiplexer/demultiplexer **157** and further fed to the erbium doped fiber **141** to excite the erbium doped fiber **141**, whereby the optical signal transmitted on the optical transmission line **121** is amplified by the erbium doped fiber **141** and then amplified signal is transmitted to the second wavelength multiplexer/demultiplexer **158**. The second excitation light is emitted from the excitation light source **164** and then transmitted through the second subordinate optical transmission line **123** to the second wavelength multiplexer/demultiplexer **158**. The second excitation light is multiplexed with the optical signal by the first wavelength multiplexer/demultiplexer **158** and further fed to the erbium doped fiber **141** to excite the erbium doped fiber **141**, whereby the optical signal transmitted on the optical transmission line **121** is amplified by the erbium doped fiber **141** and then amplified signal is transmitted to the second wavelength multiplexer/demultiplexer **158**.

The first excitation light has a large intensity for causing an excitation of the erbium doped fiber **141**. A majority part of the first excitation light is absorbed into the erbium doped fiber **141** for excitation of the erbium doped fiber **141**, whilst a majority part of the first excitation light is not absorbed into the erbium doped fiber **141** and then transmitted through the erbium doped fiber **141**. This transmitted first excitation light remains to have the large intensity. Actually, this remaining first excitation light is multiplexed with the optical signal. However, the second wavelength multiplexer/demultiplexer **158** is operated for demultiplexing the signal into the optical signal having the wavelength of 1550 nanometers and the remaining first excitation light having the wavelength of 1480 nanometers, whereby the second wavelength multiplexer/demultiplexer **158** sends the optical signal having the wavelength of 1550 nanometers on the optical transmission line **121** and also sends the remaining first excitation light having the wavelength of 1480 nanometers on the second subordinate optical transmission line **123**

to avoid the transmission of the remaining first excitation light on the optical transmission line 121. The optical transmission line 121 may be connected to an optical multiplexer/demultiplexer. However, the optical multiplexer/demultiplexer receives no first excitation light, whereby the optical multiplexer/demultiplexer is free from any damage by the first excitation light. If the optical transmission line 121 is connected to other optical device, then the optical device receives no first excitation light, whereby the optical device is free from any damage by the first excitation light.

The second excitation light has a large intensity for causing an excitation of the erbium doped fiber 141. A majority part of the second excitation light is absorbed into the erbium doped fiber 141 for excitation of the erbium doped fiber 141, whilst a minority part of the second excitation light is not absorbed into the erbium doped fiber 141 and then transmitted through the erbium doped fiber 141. This transmitted second excitation light remains to have the large intensity. Actually, this remaining second excitation light is multiplexed with the optical signal. However, the first wavelength multiplexer/demultiplexer 157 is operated for demultiplexing the signal into the optical signal having the wavelength of 1550 nanometers and the remaining second excitation light having the wavelength of 1480 nanometers, whereby the first wavelength multiplexer/demultiplexer 157 sends the optical signal having the wavelength of 1550 nanometers on the optical transmission line 121 and also sends the remaining second excitation light having the wavelength of 1480 nanometers on the second subordinate optical transmission line 123 to avoid the transmission of the remaining second excitation light on the optical transmission line 121. The optical transmission line 121 may be connected to an optical multiplexer/demultiplexer. However, the optical multiplexer/demultiplexer receives no second excitation light, whereby the optical multiplexer/demultiplexer is free from any damage by the second excitation light. If the optical transmission line 121 is connected to other optical device, then the optical device receives no second excitation light, whereby the optical device is free from any damage by the second excitation light.

The use of the first and second excitation light sources reduces the required intensity of the individual excitation light.

TWENTY FIRST EMBODIMENT

A twenty first embodiment according to the present invention will be described in detail with reference to FIG. 24 which is a novel wavelength-multiplexed optical add-drop multiplexer including the above optical multiplexer/demultiplexers utilizing the above novel optical gate switches having the same structure as illustrated in FIG. 22, wherein band-pass filters 171 and 172 are used in place of wavelength band selective optical reflecting mirror 25 of FIG. 22 as well as utilizing the above novel optical gate switches having the same structure as illustrated in FIG. 21.

TWENTY SECOND EMBODIMENT

A twenty second embodiment according to the present invention will be described in detail with reference to FIG. 25 which is a novel wavelength-multiplexed optical add-drop multiplexer which is modified from the above novel wavelength-multiplexed optical add-drop multiplexer of FIG. 15 by utilizing the above novel optical gate switches having the same structure as illustrated in FIG. 21.

TWENTY FOURTH EMBODIMENT

A twenty fourth embodiment according to the present invention will be described in detail with reference to FIG. 26 which is a novel wavelength-multiplexed optical add-drop multiplexer which is modified from the above novel wavelength-multiplexed optical add-drop multiplexer of FIG. 16 by utilizing the above novel optical gate switches having the same structure as illustrated in FIG. 22, wherein band-pass filters 171 and 172 are used in place of wavelength band selective optical reflecting mirror 25 of FIG. 22 as well as utilizing the above novel optical gate switches having the same structure as illustrated in FIG. 21.

TWENTY FOURTH EMBODIMENT

A twenty fourth embodiment according to the present invention will be described in detail with reference to FIG. 27 which is a novel wavelength-multiplexed optical add-drop multiplexer utilizing the above novel optical gate switches having the same structure as illustrated in FIG. 22, wherein band-pass filters 171 and 172 are used in place of wavelength band selective optical reflecting mirror 25 of FIG. 22.

TWENTY FIFTH EMBODIMENT

A twenty fifth embodiment according to the present invention will be described in detail with reference to FIG. 28 is a novel wavelength-multiplexed optical add-drop multiplexer which is modified from the above novel wavelength-multiplexed optical add-drop multiplexer of FIG. 15 by eliminating optical transmitters and replacing optical receivers by a combination of band pass filters 171, 172, 173 and 174 with a monitor 200.

TWENTY SIXTH EMBODIMENT

A twenty sixth embodiment according to the present invention will be described in detail with reference to FIG. 29 which is a novel wavelength-multiplexed optical add-drop multiplexer which is modified from the above novel wavelength-multiplexed optical add-drop multiplexer of FIG. 19 by replacing optical amplifiers with the above novel optical gate switches having the same structure as illustrated in FIG. 22, wherein band-pass filters 171 and 172 are used in place of wavelength band selective optical reflecting mirror 25 of FIG. 22.

Whereas modifications of the present invention will be apparent to a person having ordinary skill in the art, to which the invention pertains, it is to be understood that embodiments as shown and described by way of illustrations are by no means intended to be considered in a limiting sense. Accordingly, it is to be intended to cover by claims all modifications which fall within the spirit and scope of the present invention.

What is claimed is:

1. An optical switch including:

- at least a plurality of optical transmission lines for transmissions of optical signals, each of said at least plurality of optical transmission lines having at least an impurity doped fiber;
- at least an excitation light source for emitting an excitation light; and
- at least an excitation light switch connected to said excitation light source and also connected to said at least plurality of optical transmission lines for individual switching operations to supply said excitation light to said at least plurality of optical transmission

lines to feed said excitation light to said impurity doped fiber on said at least plurality of optical transmission lines, thereby causing an excitation of said impurity doped fiber on selected one of said at least plurality of optical transmission lines so as to permit a transmission of said optical signal through said excited impurity doped fiber, whilst unselected one of said impurity doped fibers is unexcited whereby said optical signals are absorbed into said unselected one of said impurity doped fibers thereby to discontinue transmission of said optical signal by said unselected one of said impurity doped fibers,

wherein said optical switch further includes:

- a single input side optical transmission line; and
- a single input side optical coupler connected to said single input side optical transmission line, and

wherein said at least plurality of optical transmission lines comprise first and second optical transmission lines which are connected through said single input side optical coupler to said single input side optical transmission line, and said first and second optical transmission lines have first and second impurity doped fibers, and

wherein said at least excitation light source comprises a single excitation light source, and said at least excitation light switch comprises a single excitation light switch which has first and second output terminals for selecting any one of said first and second output terminals, and said first output terminal is connected through a first optical coupler to said first impurity doped fiber to feed said excitation light to said first impurity doped fiber only when said first output terminal is selected by said single excitation light switch, and said second output terminal is connected through a second optical coupler to said second impurity doped fiber to feed said excitation light to said second impurity doped fiber only when said second output terminal is selected by said single excitation light switch,

a first optical reflective mirror provided on one end of said first optical transmission line for reflecting said first optical signal passed through said first impurity doped fiber excited so that said reflected first optical signal is again transmitted through said first impurity doped fiber excited to an opposite end as an output terminal of said first optical transmission line;

a first optical isolator provided between said input side optical coupler and said first optical transmission line for permitting a unidirectional transmission of an optical signal from said input side optical coupler to said first optical transmission line;

a second optical reflective mirror provided on one end of said second optical transmission line for reflecting said second optical signal passed through said second impurity doped fiber excited so that said reflected second optical signal is again transmitted through said second impurity doped fiber excited to an opposite end as an output terminal of said second optical transmission line; and

a second optical isolator provided between said input side optical coupler and said second optical transmission line for permitting a unidirectional transmission of an optical signal from said input side optical coupler to said second optical transmission line.

2. An optical switch including:

at least a plurality of optical transmission lines for transmissions of optical signals, each of said at least plu-

rality of optical transmission lines having at least an impurity doped fiber;

at least an excitation light source for emitting an excitation light; and

at least an excitation light switch connected to said excitation light source and also connected to said at least plurality of optical transmission lines for individual switching operations to supply said excitation light to said at least plurality of optical transmission lines to feed said excitation light to said impurity doped fiber on said at least plurality of optical transmission lines, thereby causing an excitation of said impurity doped fiber on selected one of said at least plurality of optical transmission lines so as to permit a transmission of said optical signal through said excited impurity doped fiber, whilst unselected one of said impurity doped fibers is unexcited whereby said optical signals are absorbed into said unselected one of said impurity doped fibers thereby to discontinue transmission of said optical signal by said unselected one of said impurity doped fibers,

wherein said optical switch further includes:

- a single input side optical transmission line; and
- a single input side optical coupler connected to said single input side optical transmission line, and

wherein said at least plurality of optical transmission lines comprise first and second optical transmission lines which are connected through said single input side optical coupler to said single optical transmission line, and said first and second optical transmission lines have first and second impurity doped fibers, and

wherein said at least excitation light source comprises a single excitation light source, and said at least excitation light switch comprises a single excitation light switch which has first and second output terminals for selecting any one of said first and second output terminals, and said first output terminal is connected through a first optical coupler to said first impurity doped fiber to feed said excitation light to said first impurity doped fiber only when said first output terminal is selected by said single excitation light switch, and said second output terminal is connected through a second optical coupler to said second impurity doped fiber to feed said excitation light to said second impurity doped fiber only when said second output terminal is selected by said single excitation light switch,

a first optical reflective mirror provided on one end of said first optical transmission line for reflecting said first optical signal passed through said first impurity doped fiber excited so that said reflected first optical signal is again transmitted through said first impurity doped fiber excited to an opposite end as an output terminal of said first optical transmission line;

a second optical reflective mirror provided on one end of said second optical transmission line for reflecting said second optical signal passed through said second impurity doped fiber excited so that said reflected second optical signal is again transmitted through said second impurity doped fiber excited to an opposite end as an output terminal of said second optical transmission line; and

a circulator as said input side optical coupler and an optical isolator provided between said input side optical transmission line and said first and second optical transmission lines.

3. An optical switch including:
 at least a plurality of optical transmission lines for trans-
 missions of optical signals, each of said at least plu-
 rality of optical transmission lines having at least an
 impurity doped fiber; 5
 at least an excitation light source for emitting an excita-
 tion light; and
 at least an excitation light switch connected to said
 excitation light source and also connected to said at
 least plurality of optical transmission lines for indi- 10
 vidual switching operations to supply said excitation
 light to said at least plurality of optical transmission
 lines to feed said excitation light to said impurity doped
 fiber on said at least plurality of optical transmission
 lines, thereby causing an excitation of said impurity 15
 doped fiber on selected one of said at least plurality of
 optical transmission lines so as to permit a transmission
 of said optical signal through said excited impurity
 doped fiber, whilst unselected one of said impurity
 doped fibers is unexcited whereby said optical signals
 are absorbed into said unselected one of said impurity 20
 doped fibers thereby to discontinue transmission of said
 optical signal by said unselected one of said impurity
 doped fibers,
 wherein said optical switch has two inputs and two 25
 outputs and comprises a pair of first and second optical
 switches connected to each other through at least an
 interconnecting optical transmission line, and
 wherein each of said first and second optical switches
 further comprises:
 a single input side optical coupler connected to said 30
 single input side optical transmission line;
 first and second optical transmission lines which are
 connected through said single input side optical
 coupler to said single input side optical transmission 35
 line, and said first and second optical transmission
 lines having first and second impurity doped fibers;
 a single excitation light source; and
 a single excitation light switch has first and second 40
 output terminals for selecting any one of said first
 and second output terminals, and said first output
 terminal being connected through a first optical
 coupler to said first impurity doped fiber to feed said 45
 excitation light to said first impurity doped fiber only
 when said first output terminal is selected by said
 single excitation light switch, and said second output
 terminal being connected through a second optical
 coupler to said second impurity doped fiber to feed
 said excitation light to said second impurity doped 50
 fiber only when said second output terminal is
 selected by said single excitation light switch.

4. The optical switch as claimed in claim 3, wherein each
 of said first and second optical switches further comprises:
 a first optical filter provided on said first optical trans- 55
 mission line and positioned between said first optical
 coupler and an output terminal of said first optical
 transmission line so as to remove a noise from said first
 optical signal when said first impurity doped fiber is
 excited; and
 a second optical filter provided on said second optical 60
 transmission line and positioned between said second
 optical coupler and an output terminal of said second
 optical transmission line so as to remove a noise from
 said second optical signal when said second impurity
 doped fiber is excited.

5. The optical switch as claimed in claim 3, wherein each
 of said first and second optical switches further comprises:

a first optical reflective mirror provided on one end of said
 first optical transmission line for reflecting said first
 optical signal passed through said first impurity doped
 fiber excited so that said reflected first optical signal is
 again transmitted through said first impurity doped 5
 fiber excited to an opposite end as an output terminal of
 said first optical transmission line;

a first optical isolator provided between said input side
 optical coupler and said first optical transmission line
 for permitting a unidirectional transmission of an opti- 10
 cal signal from said input side optical coupler to said
 first optical transmission line;

a second optical reflective mirror provided on one end of
 said second optical transmission line for reflecting said 15
 second optical signal passed through said second impu-
 rity doped fiber excited so that said reflected second
 optical signal is again transmitted through said second
 impurity doped fiber excited to an opposite end as an
 output terminal of said second optical transmission
 line; and

a second optical isolator provided between said input side
 optical coupler and said second optical transmission
 line for permitting a unidirectional transmission of an 20
 optical signal from said input side optical coupler to
 said second optical transmission line.

6. The optical switch as claimed in claim 3, wherein each
 of said first and second optical switches further comprises:
 a first optical reflective mirror provided on one end of said 25
 first optical transmission line for reflecting said first
 optical signal passed through said first impurity doped
 fiber excited so that said reflected first optical signal is
 again transmitted through said first impurity doped
 fiber excited to an opposite end as an output terminal of
 said first optical transmission line;

a second optical reflective mirror provided on one end of
 said second optical transmission line for reflecting said 30
 second optical signal passed through said second impu-
 rity doped fiber excited so that said reflected second
 optical signal is again transmitted through said second
 impurity doped fiber excited to an opposite end as an
 output terminal of said second optical transmission
 line; and

a circulator as said input side optical coupler and an
 optical isolator provided between said input side optical
 transmission line and said first and second optical 35
 transmission lines.

7. The optical switch as claimed in claim 3, wherein, for
 each of said first and second optical switches, said first
 optical coupler is inserted between said first impurity doped
 fiber and an output terminal of said first optical transmission
 line so as to feed said excitation light to said first impurity
 doped fiber in an opposite direction to a transmission of said
 first optical signal through said first impurity doped fiber 40
 excited, and also said second optical coupler is inserted
 between said second impurity doped fiber and an output
 terminal of said second optical transmission line so as to
 feed said excitation light to said second impurity doped
 fiber in an opposite direction to a transmission of said
 second optical signal through said second impurity doped
 fiber excited.

8. The optical switch as claimed in claim 3, wherein, for
 each of said first and second optical switches, said first
 optical coupler is inserted between said first impurity doped
 fiber and said input side optical coupler so as to feed said
 excitation light to said first impurity doped fiber in the same
 direction as a transmission of said first optical signal through 45
 said first optical transmission line.

said first impurity doped fiber excited, and also second optical coupler is inserted between said second impurity doped fiber and said input side optical coupler so as to feed said excitation light to said second impurity doped fiber in the same direction as a transmission of said second optical signal through said second impurity doped fiber excited. 5

9. An optical switch including:

at least a plurality of optical transmission lines for transmissions of optical signals, each of said at least plurality of optical transmission lines having at least an impurity doped fiber; 10

at least an excitation light source for emitting an excitation light; and

at least an excitation light switch connected to said excitation light source and also connected to said at least plurality of optical transmission lines for individual switching operations to supply said excitation light to said at least plurality of optical transmission lines to feed said excitation light to said impurity doped fiber on said at least plurality of optical transmission lines, thereby causing an excitation of said impurity doped fiber on selected one of said at least plurality of optical transmission lines so as to permit a transmission of said optical signal through said excited impurity doped fiber, whilst unselected one of said impurity doped fibers is unexcited whereby said optical signals are absorbed into said unselected one of said impurity doped fibers thereby to discontinue transmission of said optical signal by said unselected one of said impurity doped fibers, 15 20 25 30

wherein said optical switch has two inputs and two outputs and comprises a pair of first and second optical

switches connected to each other through at least an interconnecting optical transmission line, and a common excitation line source connected to said first and second optical switches, and

wherein each of said first and second optical switches further comprises:

a single input side optical coupler connected to said single input side optical transmission line;

first and second optical transmission lines which are connected through said single input side optical coupler to said single input side optical transmission line, and said first and second optical transmission lines having first and second impurity doped fibers; and

a single excitation light switch connected to said common excitation light source, said single excitation light switch having first and second output terminals for selecting any one of said first and second output terminals, and said first output terminal being connected through a first optical coupler to said first impurity doped fiber to feed said excitation light to said first impurity doped fiber only when said first output terminal is selected by said single excitation light switch, and said second output terminal being connected through a second optical coupler to said second impurity doped fiber to feed said excitation light to said second impurity doped fiber only when said second output terminal is selected by said single excitation light switch.

* * * * *