

(No Model.)

J. H. MAYER.
LET-OFF MECHANISM FOR LOOMS.

No. 520,603.

Patented May 29, 1894.

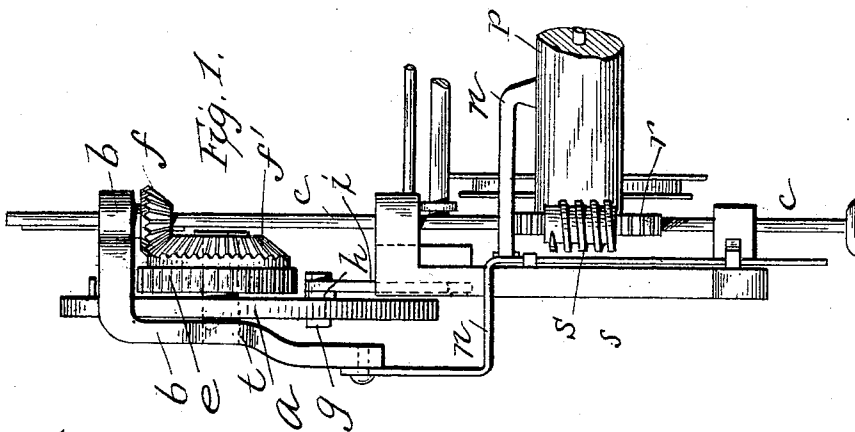
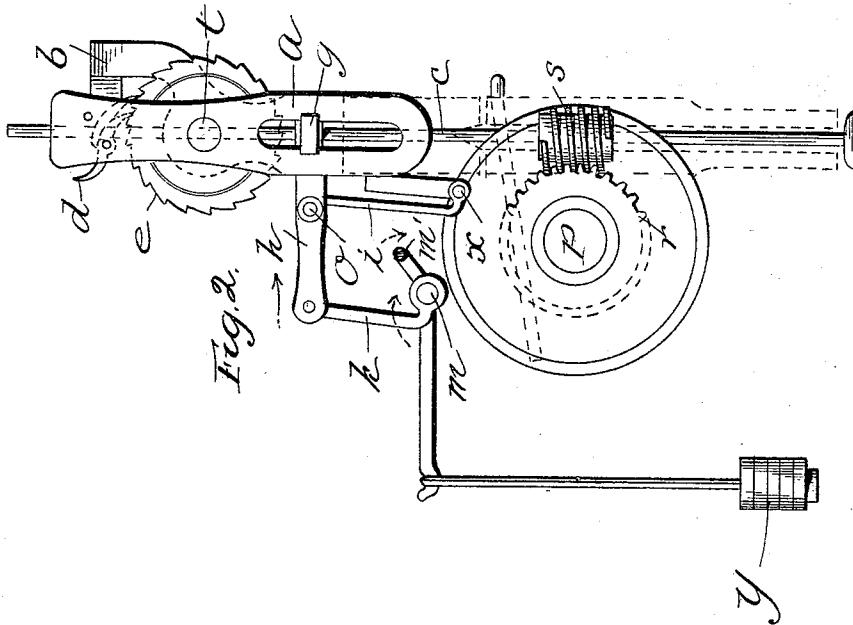

Attest
Walter Middleton
F. L. Middleton

Inventor
John Henry Mayer
by *Richardson & Co*
ATTYS

UNITED STATES PATENT OFFICE.

JOHN H. MAYER, OF WATERLOO, CANADA.

LET-OFF MECHANISM FOR LOOMS.

SPECIFICATION forming part of Letters Patent No. 520,603, dated May 29, 1894.

Application filed May 5, 1893. Serial No. 473,160. (No model.)

To all whom it may concern:

Be it known that I, JOHN HENRY MAYER, a subject of the Queen of Great Britain and Ireland, and a resident of the town of Waterloo, Ontario, in the county of Waterloo and Province of Ontario, in the Dominion of Canada, have invented a certain new and useful Improvement in Let-Off Mechanisms for Looms, of which the following is a specification.

This invention relates to improvements in the let off mechanism of looms. It consists in the arrangement and construction of the operating parts as hereinafter described and has for its object the regulation of the motion of the warp beam so as to keep the warp at an even tension and to overcome the increasing strain thereon as the diameter of the warp roll decreases.

Referring to the drawings which form a part of this specification Figure 1 is an end view of a sufficient part of a loom to illustrate my invention. Fig. 2 is a side view.

The drawings show no part of the loom frame which may be of any suitable shape having proper bearings for the journals of the warp beam, "p" on which is a worm gear "r" which is engaged by the worm "s" on the upright shaft "c," which at its base may have its bearing upon the floor or secured to some part of the loom frame. The worm shaft "c" passes through and has its bearing in a loose collar in the movable frame "b." Upon such shaft and immediately below such loose collar the pinion "f" is loosely keyed or otherwise fitted so as to revolve the shaft "c" and at the same time to allow the pinion to rise or fall on such shaft as the frame "b" is raised or lowered. The pinion "f" engages with the pinion f' attached to the ratchet "e" which is actuated by the pawl or pawls "d" attached to the pawl carrier "a" having its fulcrum on the short shaft "i" having its bearing in the frame "b." The lower end of the pawl carrier "a" is slotted to receive the pin "g" on the lever "h." This lever "h" has its fulcrum "o" pivoted on the rod "i" which is pivoted on the loom frame at "x." The other end of the lever "h" is connected by the rod "k" with the whip roll "m." To the movable frame "b" by means of the shaft "t" are secured the pawl carrier "a" the ratchet "e" and

the pinion "f'." To the lower part of the movable frame "b" is also attached the arm "n" which is so bent and adjusted as to rest upon the warp roll and thereby to support such frame "b" upon the shaft "c."

Any suitable form of connection may be used for operating the whip roll positively to return the parts after being operated by the strain of the warp such for instance as that shown in United States Patent No. 264,864, of September 26, 1882.

My invention is operated in the following manner: As each stroke of the lay takes up a certain amount of the warp, the strain on the warp caused thereby depresses the bar "m'." Each depression of this bar causes a partial revolution of the whip roll "m" and a consequent forward motion of the rod "k." This by means of the lever "h" which now moves longitudinally in the direction of the arrow, Fig. 2, owing to its supporting rod being free to turn at point x is communicated to the pawl carrier "a" thus causing the pawl "d" to travel a certain distance upon the ratchet "e." When by means of a suitable device the bar "m'" is restored to its former position it imparts a backward motion to the rod "k" and causes the pawl "d" to engage with the ratchet "e" and thus by means of the pinion "f'" the pinion "f" the worm shaft "c" the worm "s" and the worm gear "r" to revolve the warp beam "p." The arrows in Fig. 2, show the movement of the bar m', the whip roll and the rod k whereby the strain of the warp depresses the bar m'. As the warp roll decreases in diameter the arm "n" resting upon it allows the frame "b" and its attachments and the pinion "f'" of their own weight to slide down along the worm shaft "c" and as they sink the connection of the lever "h" with the slotted end of the pawl carrier gradually approaches nearer its fulcrum thus causing the pawl "d" to travel a greater distance on the ratchet "e" and thus transmitting to the warp beam a motion increasing as the warp is unwound from the beam.

If the different parts are constructed and adjusted with a mechanical consideration of the diameter of the warp beam the motion of the whip roll and the strain upon the warp

will be uniform throughout notwithstanding the variation in the amount of warp upon the beam.

It will be understood that as the means for operating the whip roll positively forms no part of my invention the same has not been shown or described specifically herein.

Having now described my invention, what I claim as new, and desire to secure by Letters Patent, is—

1. In combination in a let off mechanism, the beam, the worm shaft for driving the same, the mechanism for turning the worm shaft including a pawl lever and ratchet, said mechanism being arranged to slide along the worm shaft, the whip roll, the connections from said whip roll to the pawl lever, said connections having a shifting connection with said pawl lever and the support for said sliding operating mechanism said support arranged to press on the warp of the warp beam to be controlled as the same unwinds, substantially as described.

2. In combination, the warp beam, the shaft connected therewith for operating the same,

the sliding pinion on said shaft, the pawl and ratchet for operating said pinion also arranged to slide the pawl lever for operating the pawls, the whip roll, the connection therefrom to the pawl lever, said connections having a shifting joint connection with the pawl lever and the support for controlling the position of the shifting parts, said support bearing on the warp beam, substantially as described.

3. In combination, the warp beam, the whip roll, the shaft connected with the warp beam, the operating mechanism for said shaft arranged to slide thereon, the support therefor bearing on the warp beam, the whip roll and the connection therefrom to the operating mechanism having a sliding connection therewith whereby the feed stroke of said mechanism will be varied as the warp unwinds, substantially as described.

In witness whereof I have hereunto set my hand in presence of two witnesses.

JOHN H. MAYER.

Witnesses:

WM. HOGG,

J. M. SCULLY.