



US009241872B2

(12) **United States Patent**
Manico et al.

(10) **Patent No.:** **US 9,241,872 B2**
(45) **Date of Patent:** **Jan. 26, 2016**

(54) **TIMED SEQUENCE INDICATORS**

(71) Applicants: **Joseph Anthony Manico**, Rochester, NY (US); **Kevin Michael Gobeyn**, Rochester, NY (US)

(72) Inventors: **Joseph Anthony Manico**, Rochester, NY (US); **Kevin Michael Gobeyn**, Rochester, NY (US)

(73) Assignee: **EASTMAN KODAK COMPANY**, Rochester, NY (US)

(*) Notice: Subject to any disclaimer, the term of this patent is extended or adjusted under 35 U.S.C. 154(b) by 171 days.

(21) Appl. No.: **13/929,829**

(22) Filed: **Jun. 28, 2013**

(65) **Prior Publication Data**

US 2015/0001123 A1 Jan. 1, 2015

(51) **Int. Cl.**

A61J 1/03 (2006.01)
A61J 7/04 (2006.01)
G01N 31/22 (2006.01)
G07C 1/08 (2006.01)

(52) **U.S. Cl.**

CPC **A61J 1/035** (2013.01); **A61J 7/0409** (2013.01); **G01N 31/225** (2013.01); **G01N 31/229** (2013.01); **G07C 1/08** (2013.01); **G01N 31/22** (2013.01)

(58) **Field of Classification Search**

CPC B65D 85/00; A61J 1/035; A61J 1/03; A61J 7/0409; G01N 31/225; G01N 31/22; G01N 31/229; G07C 1/08
USPC 206/531, 534, 532, 538, 528; 53/477
See application file for complete search history.

(56) **References Cited**

U.S. PATENT DOCUMENTS

4,091,921 A *	5/1978	Lewis	206/363
4,945,708 A *	8/1990	Curiel	53/411
5,602,804 A	2/1997	Haas	
6,345,717 B1 *	2/2002	Flewitt	206/531
6,741,523 B1 *	5/2004	Bommarito et al.	368/327
6,916,116 B2 *	7/2005	Diekmann et al.	374/102
6,968,804 B1 *	11/2005	Barbieri et al.	116/219
7,294,379 B2	11/2007	Ko et al.	
7,808,861 B2	10/2010	Wien	
2006/0086639 A1	4/2006	Priebe et al.	
2006/0110835 A1 *	5/2006	Gohil	436/169

(Continued)

FOREIGN PATENT DOCUMENTS

DE	3028808	3/1982
EP	2 468 283 A1	6/2012

(Continued)

OTHER PUBLICATIONS

"A solvent-based intelligence ink for oxygen", Andrew Mills and David Hazafy, The Royal Society of Chemistry, The Analyst, Jan. 28, 2008, vol. 133, pp. 213-218.

(Continued)

Primary Examiner — Steven A. Reynolds

(74) *Attorney, Agent, or Firm* — David A. Novais; Nelson A. Blish; Kevin E. Spaulding

(57) **ABSTRACT**

A containment system for packaging a plurality of products that are to be accessed in a predetermined sequence. The containment system includes a plurality of product compartments that each holds at least one of the plurality of products. Indicators having a gas reactive material that changes appearance after a predetermined period of time of exposure to ambient air are deployed when gas cover seals are removed or broken to access a product in the product compartment.

15 Claims, 15 Drawing Sheets

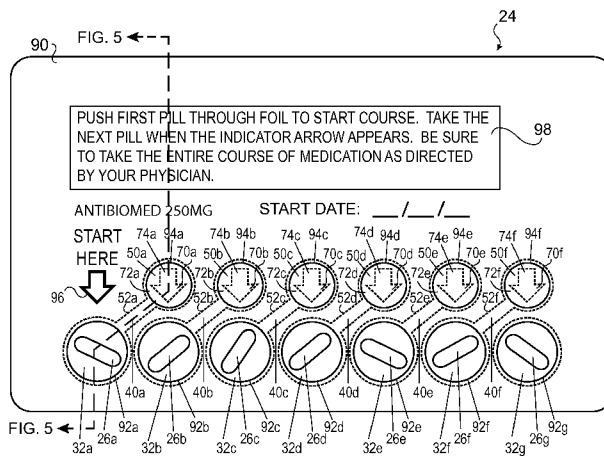

(56)

References Cited

U.S. PATENT DOCUMENTS

2009/0107873	A1 *	4/2009	Cotton et al.	206/531
2010/0143675	A1	6/2010	Guckian et al.	
2010/0193468	A1	8/2010	Burrows et al.	
2010/0221468	A1	9/2010	Khan et al.	
2011/0139655	A1	6/2011	Cochran et al.	
2014/0326635	A1 *	11/2014	Uetake, Kazuaki	206/531

FOREIGN PATENT DOCUMENTS

JP	10319148	12/1998
JP	2009-143591	7/2007
WO	WO 97/20754	6/1997
WO	WO 2004/005424	1/2004

WO WO 2010/068527 6/2010

OTHER PUBLICATIONS

“Oxygen indicators and intelligent inks for packaging food”, Andrew Mills, The Royal Society of Chemistry, Chemical Society Review, 2005, vol. 34, pp. 1003-1011.

“An intelligence ink for oxygen”, Soo-Kean Lee, Andrew Mills and Anne Lepre, The Royal Society of Chemistry, Chemical Communications, 2004, Issue 17, pp. 1912-1913.

“UV-Activated Luminescence/Colourimetric O₂ Indicator”, Andrew Mills, Cheryl Tommons, Raymond T. Bailey, M. Catriona Tedford and Peter J. Crilly, International Journal of Photoenergy, vol. 2008, Article ID 547301.

* cited by examiner

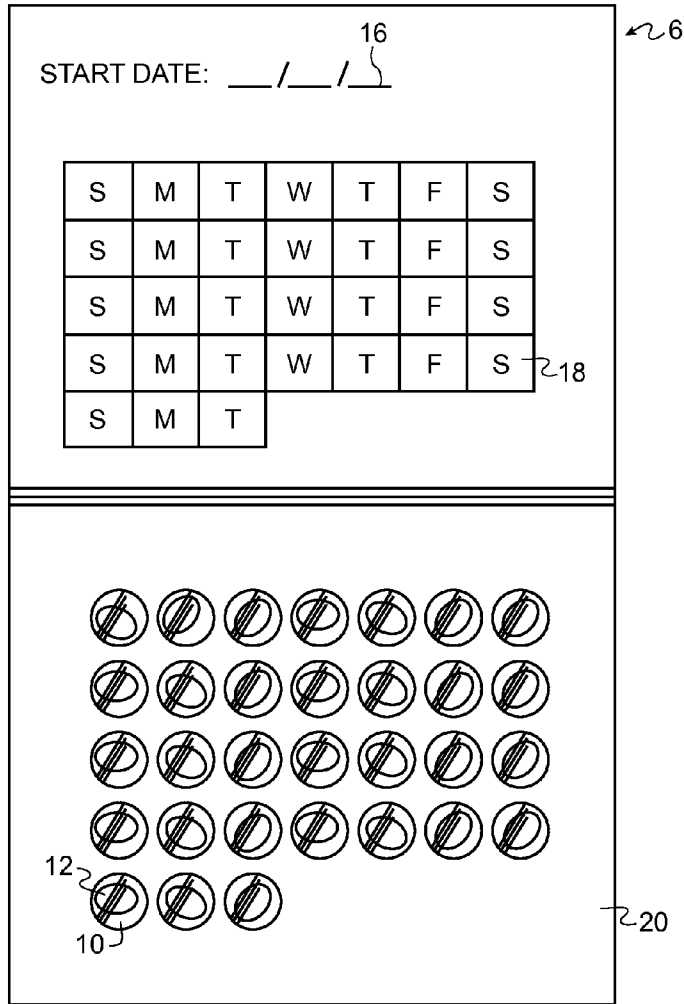

FIG. 1a
(PRIOR ART)

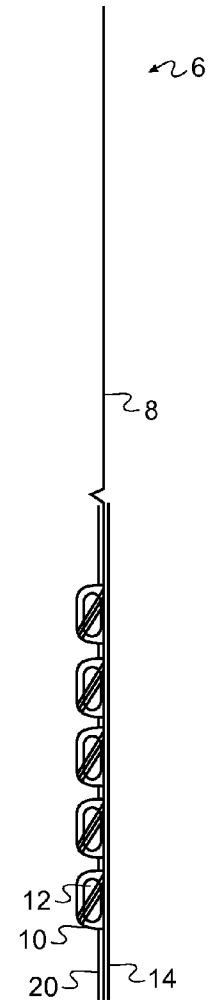

FIG. 1b
(PRIOR ART)

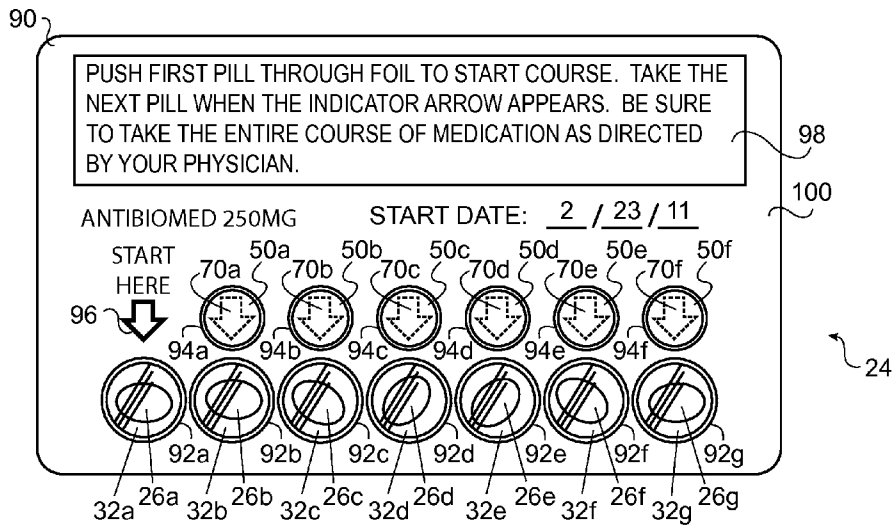

FIG. 2

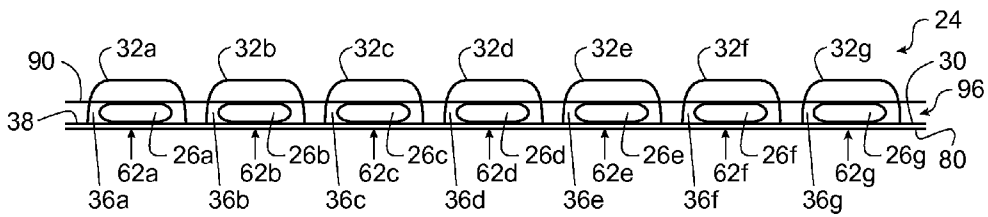

FIG. 3

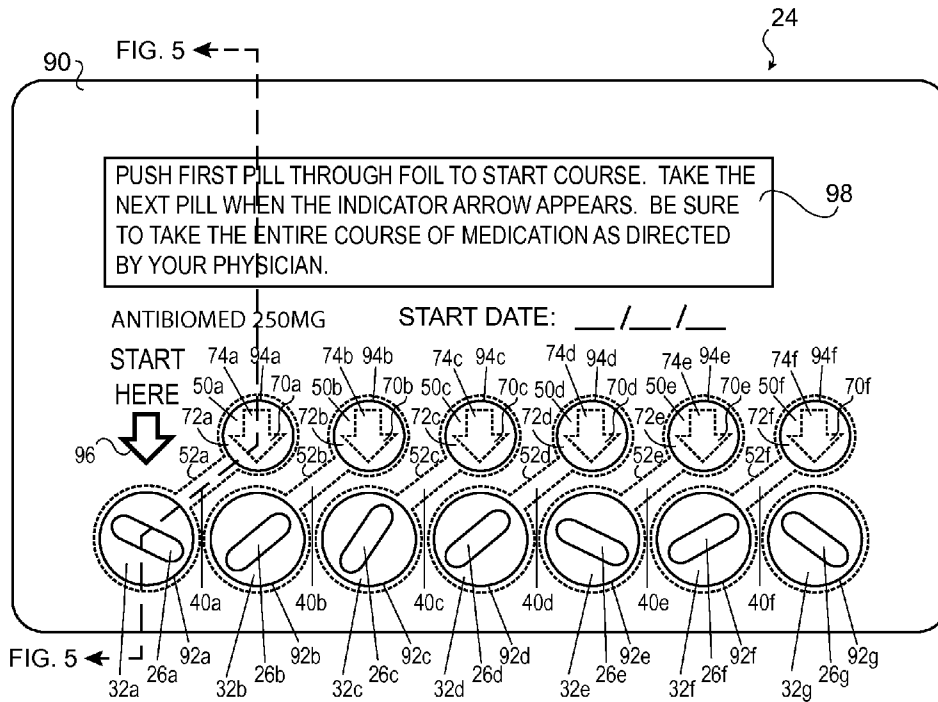

FIG. 4

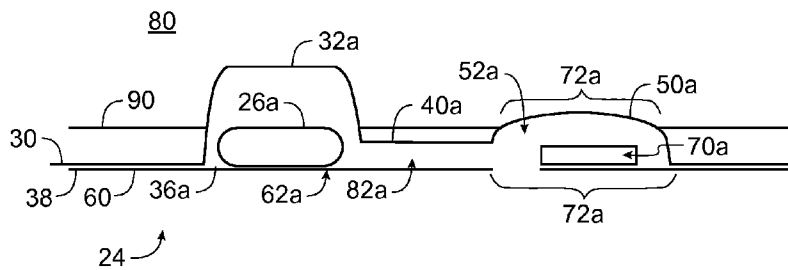

FIG. 5

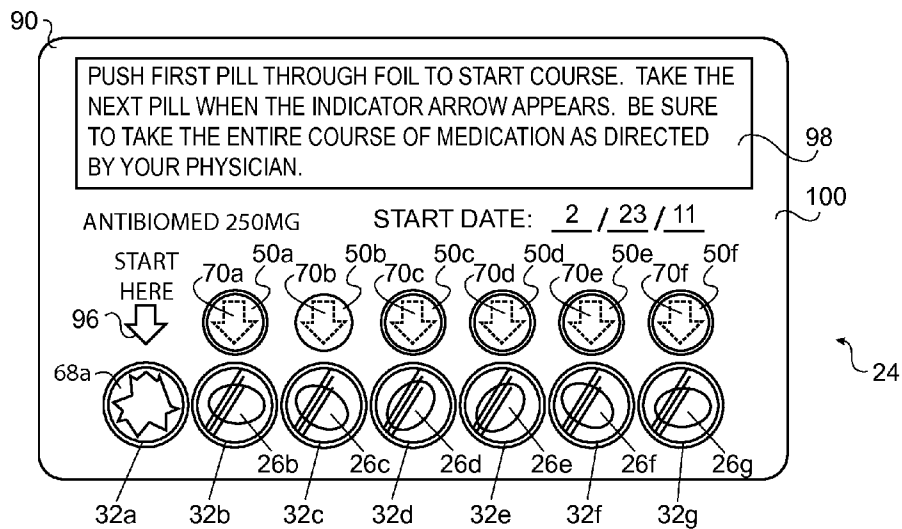

FIG. 6

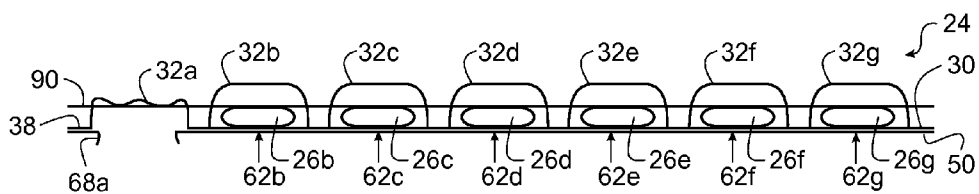

FIG. 7

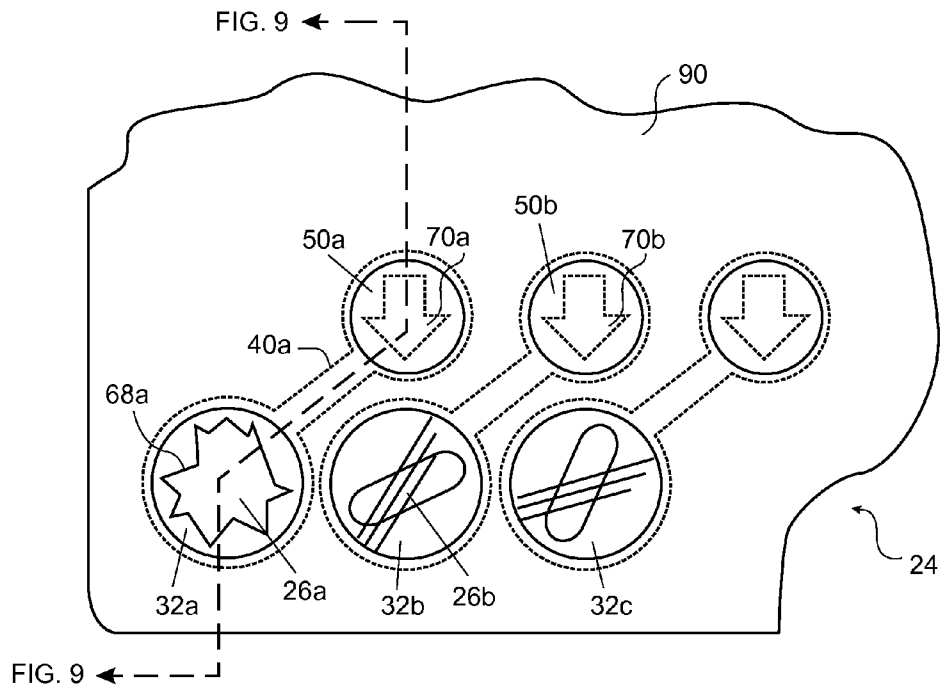

FIG. 8

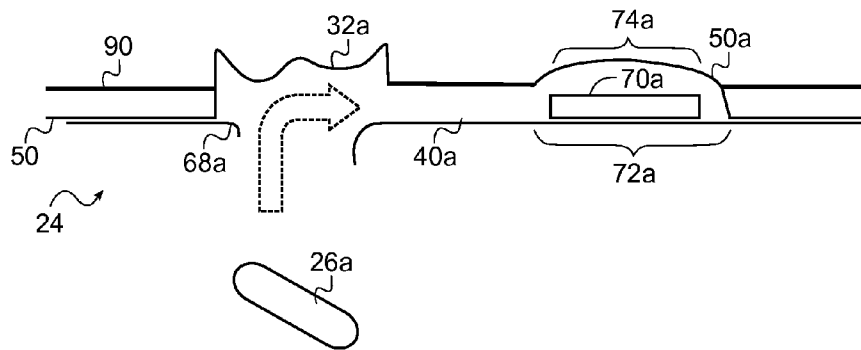

FIG. 9

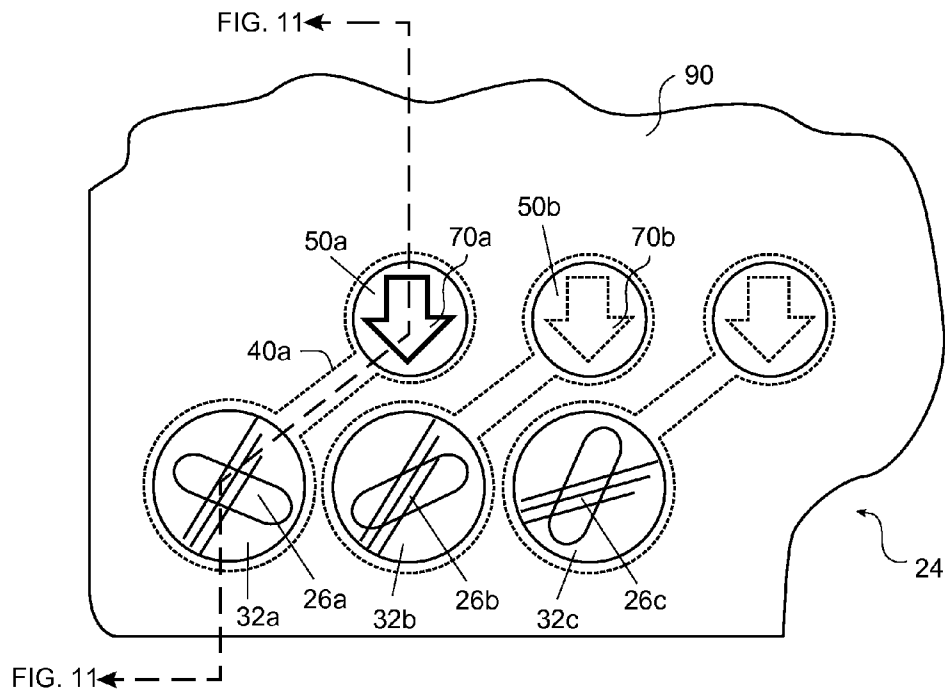

FIG. 10

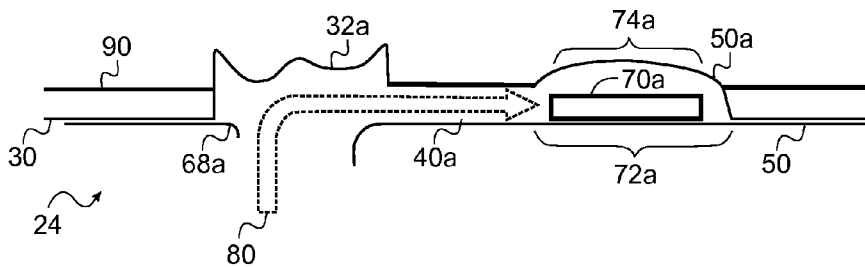
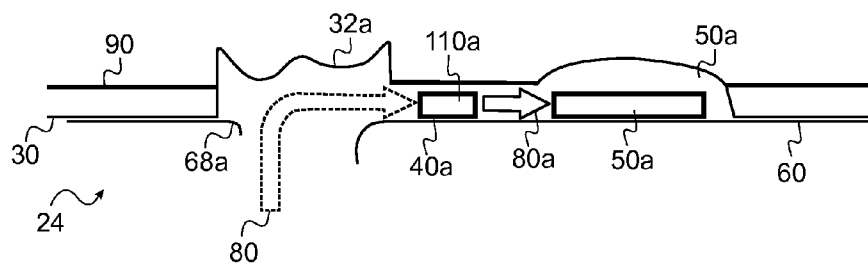
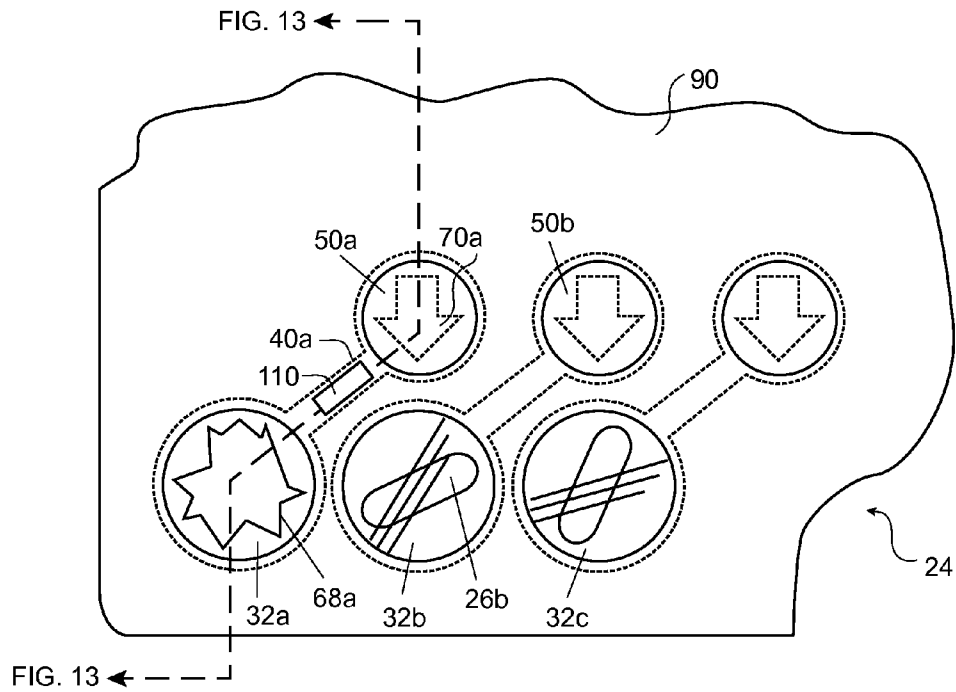

FIG. 11



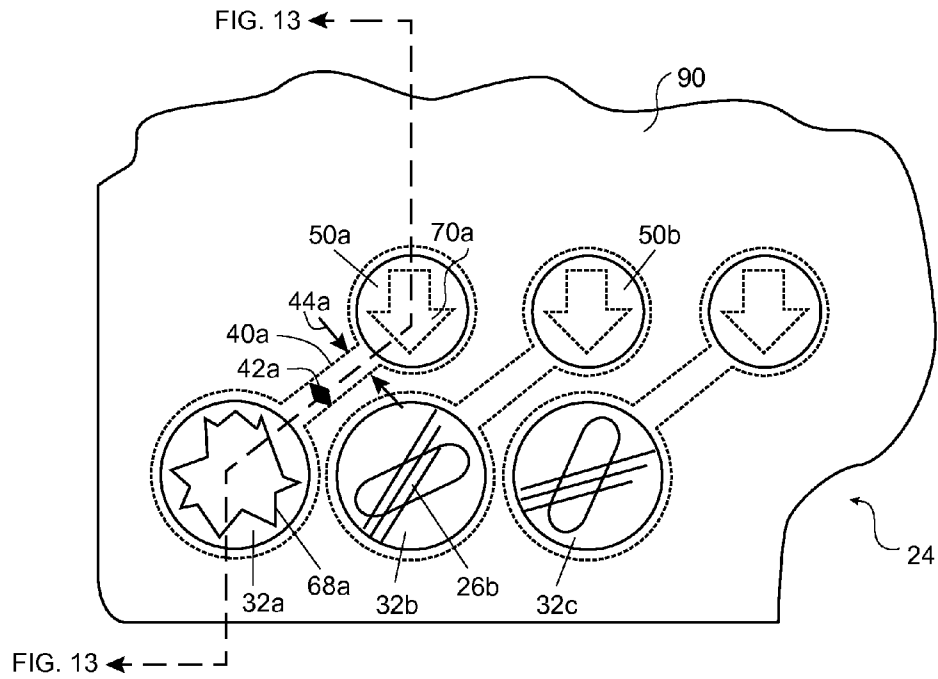

FIG. 14

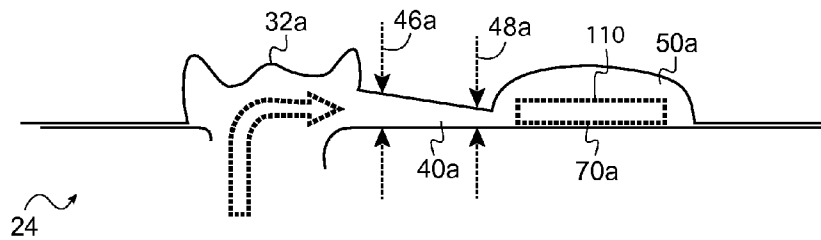

FIG. 15

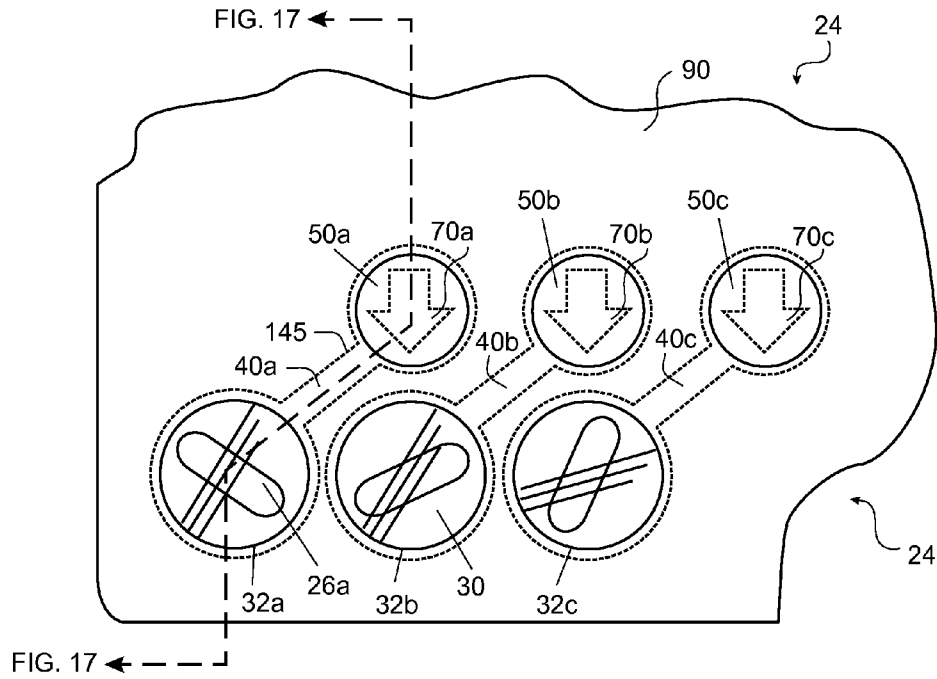

FIG. 16

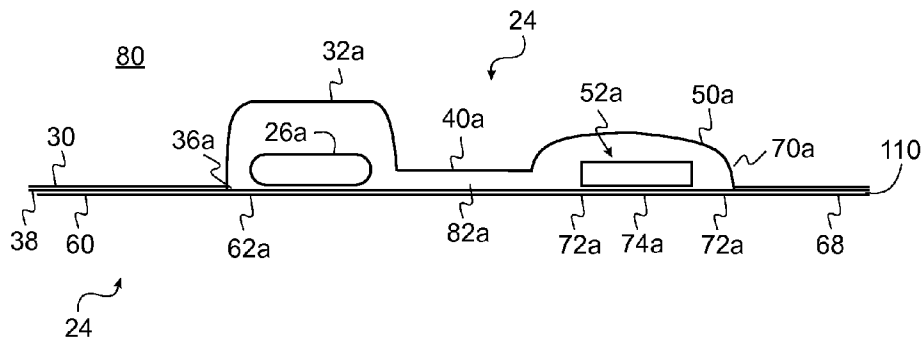

FIG. 17

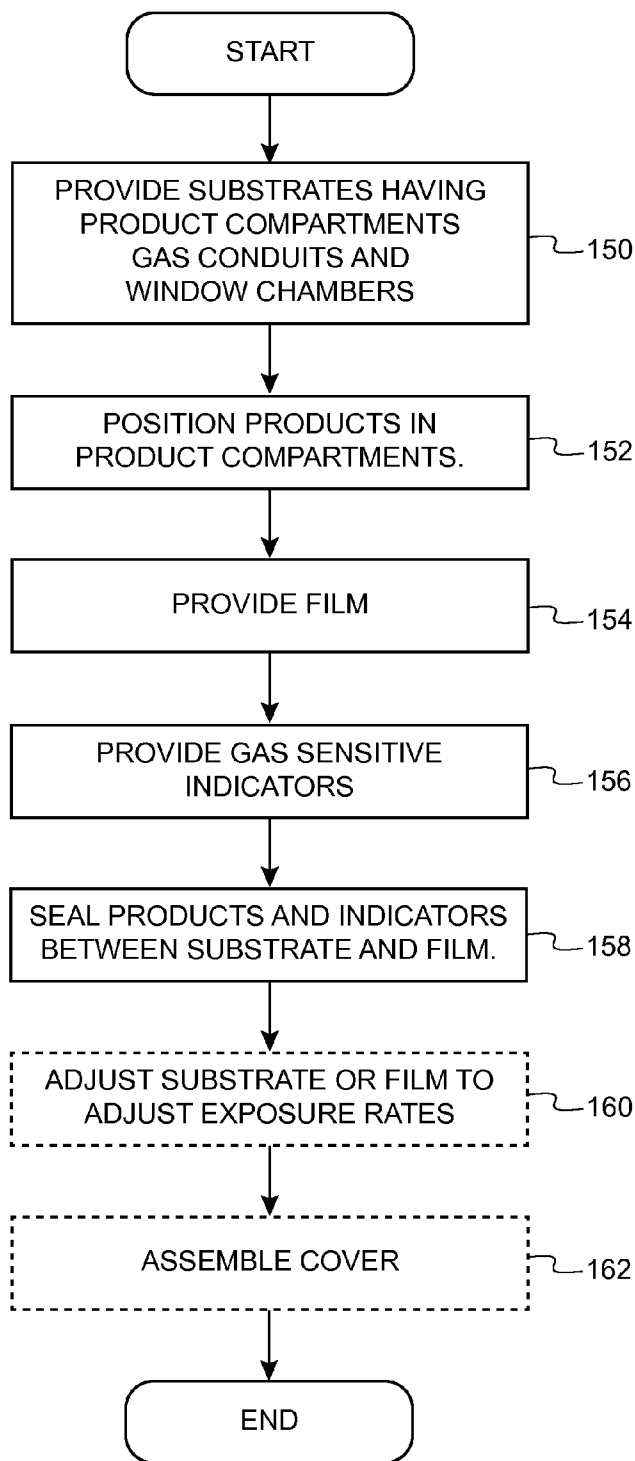

FIG. 18

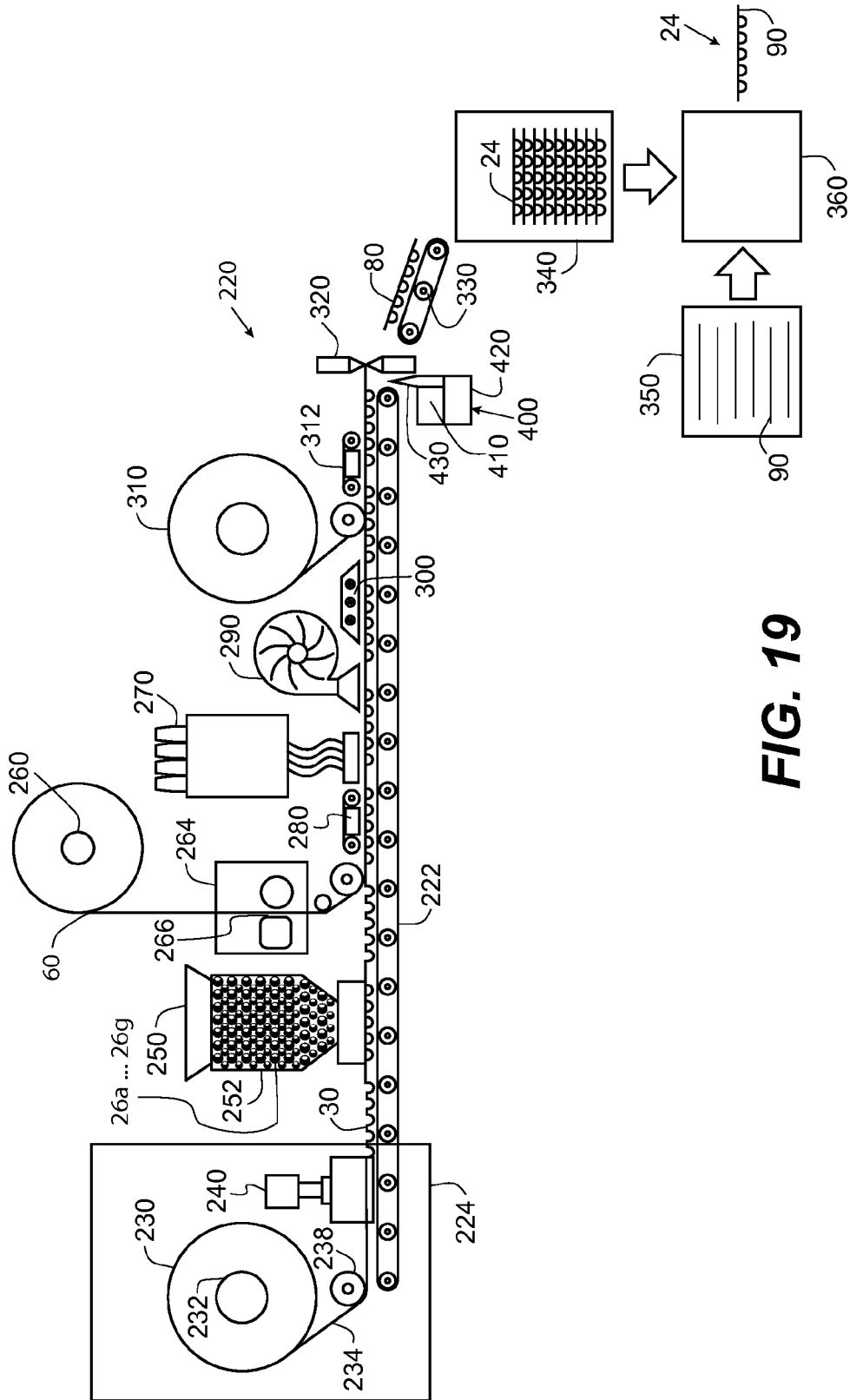

FIG. 19

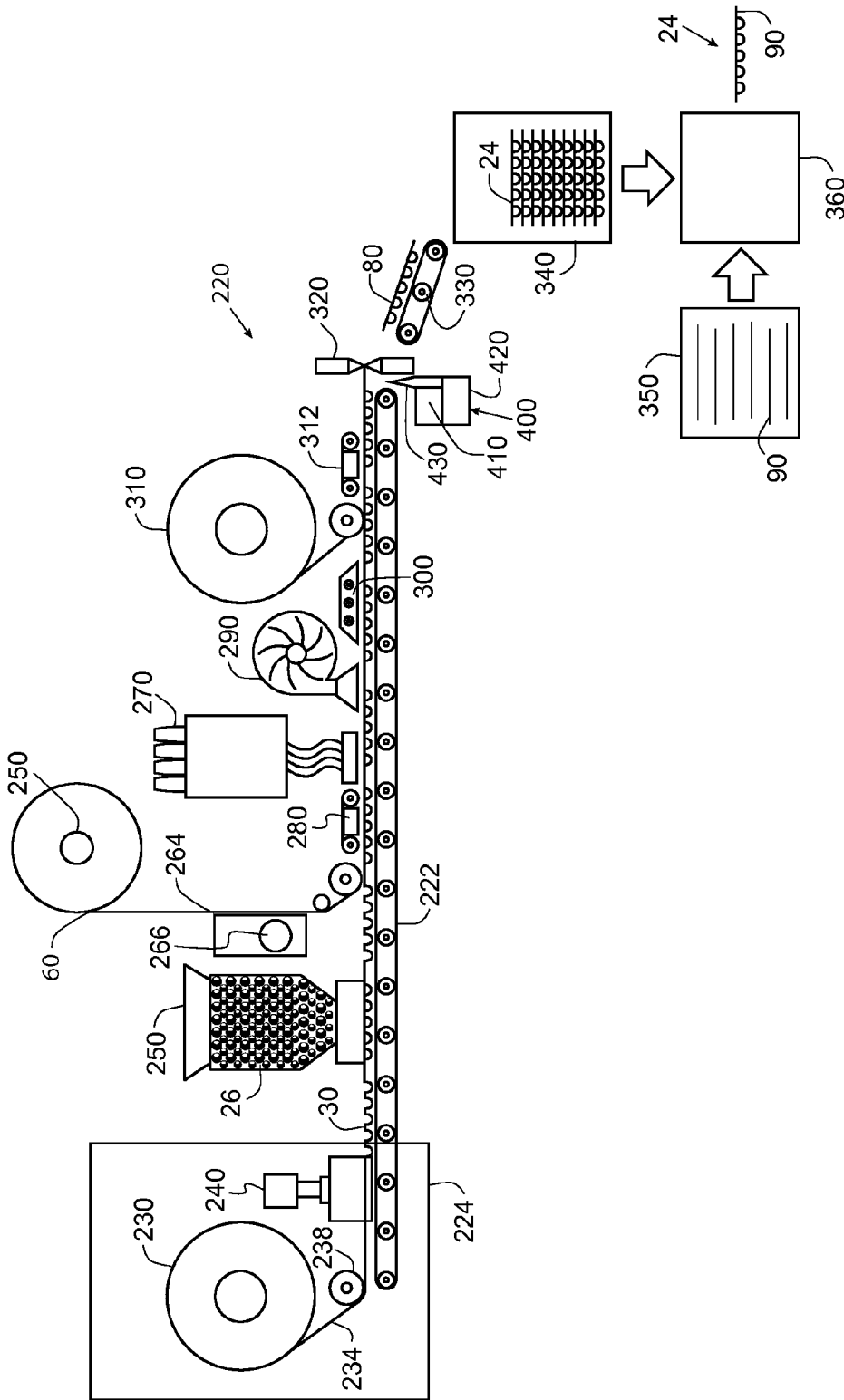

FIG. 21

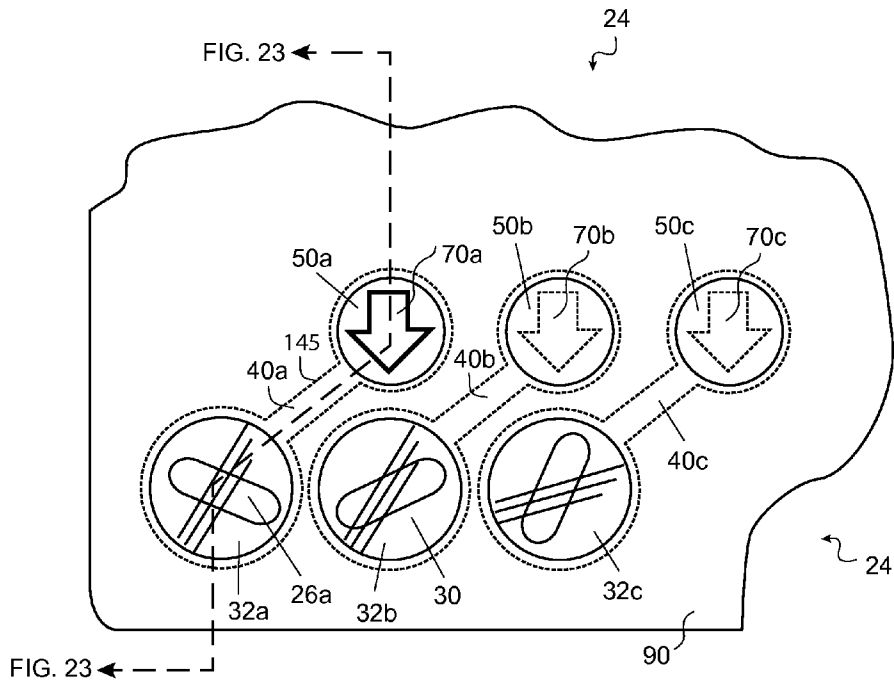

FIG. 22

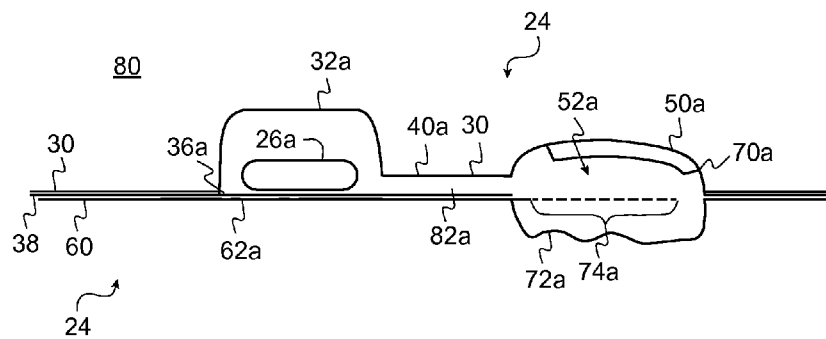

FIG. 23

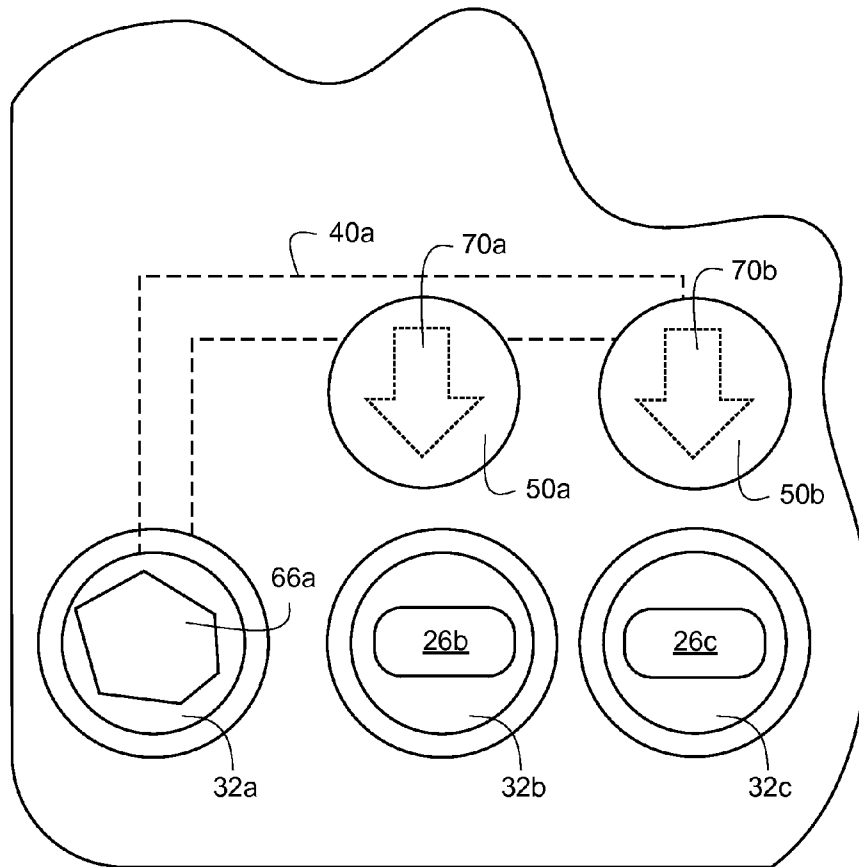

FIG. 24

TIMED SEQUENCE INDICATORS

FIELD OF THE INVENTION

The present invention relates to the field of product packaging and/or service offerings, and more particularly, to product packaging and/or service offerings that incorporate user instructions and/or notifications.

BACKGROUND OF THE INVENTION

The packing of individual products in individual containers sized for single use is becoming increasingly common for a variety of products that have previously been packaged in bulk forms. Because this transition is occurring most rapidly with respect to medical products, this type of packaging is often referred to as unit dose packaging. In some types of unit dose packaging each product has a separate container. However, this can lead to inefficiencies in manufacturing and can complicate handling by requiring the management of a multiplicity of individual items.

Accordingly, another type of unit dose packaging has emerged having a plurality of separate non-reusable unit dose containers that are physically linked often in a manner that allows the separation of the unit dose containers if later desired. For example, it is commonly known to package a plurality of pills using what is known as a blister pack. This approach provides a form of unit dose packaging that can be manufactured and handled more efficiently than separate but individual packages of pills.

Various examples of blister packs are described in WO 97/20754, entitled: "Reinforced Blister Pack". As is noted therein, blister packs generally comprise a pattern of blisters formed in a sheet of substantially impermeable deformable plastics material, each blister defining a cavity for the containment of a tablet. The open face of the blister is closed with a film cover, usually a thin, tearable metal foil or a peel-off film. The film cover can either be easily ruptured, or the film can be easily peeled away from the blister. In use either the blister is compressibly deformed so as to force the tablet therein out through a rupturable film, or the film is peeled off and the tablet is removed from the cavity. Generally the deformable material is a stiff but relatively flexible material such as a plastic material or a plastic material laminate or plastic material metal foil laminate. WO 97/20754 provides a blister pack having reinforced material between blisters to confer rigidity relative to flexing deformation of the blister pack and is said to facilitate handling by users with weak or deformed hands.

FIG. 1a is a front view and FIG. 1b is a side view of a prior art blister pack 6 used for unit dose packaging of pills 12. In the example of FIGS. 1a and 1b, blister pack 6 provides a container tray 8 with a plurality of individual containment areas 10 that can each receive one of thirty one pills 12 and a film 14 that is joined to container tray 8 and support 20 to contain pills 12 within containment areas 10. This arrangement conveniently allows packaging of an entire one month course of individual doses of pills 12. The embodiment of prior art blister pack 6 illustrated in FIGS. 1a and 1b is known in the art as a "push through pack" because it is necessary to push pills 12 through film 14 in order to access pills 12. The process of pushing pills 12 through film 14 alters prior art blister pack 10 in a variety of ways (for example, leaving an opening in film 14 at the containment area 10 from which pill 12 has been pushed). Such alterations provide a clear indication of which of pills 12 have been used, and which pills 12 remain available for use.

However, when pills 12 must be taken in a sequence and at particular times relative to each other, it is necessary to carefully prepare printed instructions and warnings. It is also necessary that the user carefully review and interpret the instructions, and properly execute the instructions to ensure that pills 12 are taken according to a desired treatment regime. This places a heavy burden on the manufacturer of pills 12 and upon the user of user pills 12 to make sure that the pills are used and taken in accordance with these instructions. Even when manufacturers and users both act diligently there can be confusion and errors in the timing, sequence and quantity of pills 12 to be taken which can negatively impact the efficacy of treatment. For example while prior art blister pack 6 requires a user to push pills 12 through film 14, leaving a clear indication that certain of pills 12 have been accessed, there is no inherent indication of when pills 12 were accessed.

Accordingly, in the example of prior art blister pack 6 shown in FIGS. 1a and 1b, the manufacturer provides a variety of printed tools to help a user to resolve such problems. As shown, prior art blister pack 6 has a printed area 16 in which starting dates can be written and a calendar 18 which can be used to provide a user with some guidance on this point. However, even where such tools are used, a user of pills 12 can be confused as to which day they are in with respect to a multi day course of treatment. That is, a user who is to take a daily course of one pill per day can observe that prior art blister pack 6 has two containment areas 10 without pills 12 but cannot recall whether today is the second or third day of a course of treatment and will be left with weighing the risks of taking too much medication or too little medication today. Further, such expedients rely both on the correct entry and use of such information. Over the course of a thirty one day treatment regime confusion is still possible particularly where such users are in pain, fatigued, or taking medications that impair or otherwise limit their analytical abilities.

In other examples, some pills 12 must be taken according to a more rigorous schedule. For example, in some cases pills 12 are to be taken within 24 hours of each other during the course of therapy. However, problems can arise if a first one of pills 12 is taken at 6:00 a.m. on a first day of treatment and a second one of pills 12 is taken at 6:00 p.m. on a second day of treatment. Conversely, where a user is subject to a treatment regime that requires that a user take pills 12 no sooner than 24 hours apart, the tools and arrangement of the prior art blister pack 6 leave open the possibility that this regime will not be followed. For example, a user can dutifully use the tools on prior art blister pack 6 while taking a first one of pills 12 at 6 p.m. on a first day of treatment, and a second one of pills 12 at 6 a.m. on a second day treatment such that pills 12 are not taken according to the regime prescribed.

The individual packaging of pills 12 in prior art blister pack 6 can also be construed by some users as impliedly suggesting that pills 12 are to be taken one at a time. However, in some cases a course of pills 12 may require that a user take pills 12 in different doses over the course of treatment such that, for example, on a first day two pills 12 must be taken while on each of the following three days only one pill 12 is to be taken. Additionally, in some cases pills 12 can be taken according to more than one possible sequence or schedule. For example, when certain pills 12 are to be used on a periodic schedule, optional instructions can be provided to allow a user to consume a first one of pills 12 and then, if symptoms for which the pills 12 are being taken persist, the user can take a second pill 12 within a shorter than normal period. In such cases great care must be taken in preparing the printed instructions for such packaging and the risk of error arising through misread-

ing instructions, misinterpreting instructions or inaccurate recollection of consumption cannot be eliminated.

This places a burden on a user to carefully manage usage of the products to accurately read, understand and follow instructions on prior art blister pack 6, and, as necessary, to set reminder systems, checklists or other processes to provide context in which to interpret the indications provided by prior art blister pack 6. Here too, while many users are capable of doing this, many pills 12 are intended for use by people whose ability to do so is limited by pain, fatigue, impaired judgment or the like. Additionally, there is the risk that a user may misunderstand the instructions, forget the instructions or specific details of the instructions.

Automatic reminder systems such as mechanical and electronic timers and clocks can be used to help remind a user as to when the user is to access the next unit dose. These devices require that the user secure such a timer and repeatedly reset the timer or otherwise program the timer so that the timer provides reminders at appropriate times. Mechanical timers have to be periodically rewound and electronic timers require batteries and need to be programmed by the user employing user interfaces with limited buttons and displays. Further, there is no inherent physical or logical integration between such timers and pills 12.

Also, automatic timers are not easily integrated into blister packs 6 as the physical format, low cost, and automated production of prior art blister packs 6 is made possible through the use of conventional blister pack manufacturing lines known in the art as "blisterlines". These blisterlines use a process that involves laminating multiple films to form a container tray 8 having appropriately sized containment areas 10, loading pills 12 and applying film 14 to container tray 8. The blisterline tooling has been highly optimized to achieve greater productivity and to minimize the cost of manufacturing conventional blister packs 6. Accordingly such tooling cannot easily be adapted in the many ways that would be required to allow conventional blisterlines to incorporate automatic mechanical or electronic timers as these timers add significant cost, size, and complexity to such tooling.

Alternatively, it is possible for a user to use reusable pill management devices such as the MedReady 1600, sold by MedReady Inc., Torrance, Calif., USA, in which a user stores pills in separate containers that are linked to a timer that indicates when the contents of container are to be used. However, this approach requires the user to transfer pills 12 from the prior art blister pack 6 to the purchased device and then properly load and configure the device to the time period required. This creates risks that pills 12 can be lost, mixed, or degraded due to exposure to atmospheric gasses and humidity.

It will be appreciated that the problems associated with prior art blister packs 6 used for medical purposes exist more generally across a wide variety of products having a combination of individually packaged components that must be used in a particular sequence and at particular times in order to achieve desired results. Indeed, a wide variety of common consumer products include blister packed items or items that can potentially be packaged in a blister pack and that require careful adherence to potentially confusing instructions which require careful adherence to a sequence of activities; where certain activities are to be performed at predetermined timings relative to each other in order to achieve desired results. Examples of this include, but are not limited to, self assembled furniture kits, ingredient packages, repair kits, emergency kits, chemical preparation kits and the like.

What is needed in the art are new product containment systems that contain products to be used collectively to

accomplish a result and that are to be used in a particular sequence and with particular timings.

SUMMARY OF THE INVENTION

The present invention accordingly relates to a containment system for a plurality of products that are to be accessed in a predetermined timed sequence. The containment system comprises a substrate with a plurality of product compartments which each have a volume sufficient to receive at least one of a plurality of products. The substrate further includes a plurality of atmospheric gas conduits each leading from one of the product compartments to a gas sensitive indicator window chamber. The containment system further comprises a plurality of gas sensitive indicators having a gas reactive material that changes appearance at a predetermined time after exposure to ambient air when gas cover seals are removed or broken to access a product in the product compartment.

The present invention further relates to a containment system for a plurality of products that are to be accessed in a timed sequence that comprises: a plurality of product compartments, with each of the product compartments being adapted to hold at least one of the plurality of products; a plurality of gas sensitive indicators adapted to change appearance after exposure to ambient air, at least one of the gas sensitive indicators being located within a gas sensitive indicator window volume; and a plurality of atmospheric gas conduits each leading from one of the product compartments to one of the gas sensitive indicator window chambers, such that an exposure of one of the product compartments to gain access to a product in the one product compartment allows atmospheric gas to flow through at least one of the plurality of atmospheric gas conduits that leads from the exposed product compartment to expose at least one of the gas sensitive indicators. The at least one gas sensitive indicator exposed to ambient air being arranged to change appearance in a manner that indicates that at least one next product in the timed sequence is to be accessed.

The present invention further relates to a method of manufacturing a containment system having time-based visual indicators which comprises: providing at least two gas sensitive indicators on a substrate, with each of the at least two indicators providing an indication directed to an adjacent space on the substrate and being adapted to change appearance at a predetermined time after exposure to ambient air; attaching user removable, gas barrier film segments substantially aligned with and covering the indicators and the substrate; and sealing the film segments to the substrate so that the indicators are isolated from ambient air.

BRIEF DESCRIPTION OF THE DRAWINGS

FIG. 1a is a front view of a prior art blister pack;
 FIG. 1b is a side view of the prior art blister pack of FIG. 1a.
 FIG. 2 is a front view of one embodiment of a product containment system according to the present invention;
 FIG. 3 is a bottom elevation view of the product containment system of FIG. 2.
 FIG. 4 is a further front view of the product containment system of FIG. 2.
 FIG. 5 is a section view of the product containment system of FIG. 2 taken as shown in FIG. 4.
 FIG. 6 is a front view of the embodiment of a product containment system shown in FIGS. 2-6 immediately after a product has been accessed;

5

FIG. 7 is a bottom elevation view of the product containment system of FIG. 6.

FIG. 8 is a cutaway view of the product containment system of FIG. 6.

FIG. 9 is a section view of the product containment system of FIG. 6 taken as shown in FIG. 8.

FIG. 10 is a top cutaway view of the product containment system of FIGS. 2-9 at a predetermined time after a product has been accessed;

FIG. 11 is a section view of the product containment system at the predetermined time after a product has been accessed taken as shown in FIG. 10.

FIG. 12 is a top cutaway view of an embodiment of a product containment system having an oxygen scavenger;

FIG. 13 is a section view of the embodiment of FIG. 12 taken as indicated in FIG. 12;

FIG. 14 is a top cutaway view of an embodiment of a product containment system having a conduit shaped to influence a predetermined time;

FIG. 15 is a section view of the embodiment of FIG. 14 taken as indicated in FIG. 14.

FIG. 16 is a cutaway view of an embodiment of a containment system having an oxygen scavenger.

FIG. 17 is a section view of the embodiment of FIG. 16 taken as indicated in FIG. 16;

FIG. 18 shows a first embodiment of a method for manufacturing a product containment system in accordance with the present invention;

FIG. 19 shows a first embodiment of an apparatus for manufacturing a product containment system in accordance with the present invention;

FIG. 20 shows an assembly view of a product containment system in accordance with the present invention;

FIG. 21 shows another embodiment of a product containment system assembly line in accordance with the present invention;

FIG. 22 shows a cut away view of another embodiment of a product containment system in accordance with the present invention;

FIG. 23 shows a section view of the embodiment of FIG. 22 taken as indicated in FIG. 22; and

FIG. 24 shows a cut away of another embodiment of a product containment system in accordance with the present invention in which two indicators have an appearance indicating that it is time to use two different products.

DETAILED DESCRIPTION OF THE INVENTION

Referring now to the drawings, wherein like reference numerals represent identical or corresponding parts throughout the several views, FIGS. 2-11 illustrate a first embodiment of a product containment system 24 in accordance with the present invention. In FIGS. 2-5 product containment system 24 is illustrated in an unused state; in FIGS. 6-9 product containment system 24 is illustrated immediately after a first product 26a in a sequence of products has been accessed; and FIGS. 10 and 11 illustrate product containment system 24 at a time when a next product 26b in a sequence of products is to be accessed.

FIGS. 2-5 respectively show a top view of product containment system 24, a bottom elevation view of product containment system 24, a further top view of product containment system 24, and a section view of product containment system 24 taken as indicated in FIG. 4. In this embodiment, product containment system 24 is used to hold a plurality of products 26a-26g. Products 26a-26g can be, for example, pills. However, the present invention is not limited to pills and products

6

26a-26g can be any type of product that needs to be dispensed in sequence such as a timed sequence. In this example, products 26b-26g are to be used in a predetermined sequence after a product 26a is used, and each product in the sequence is used at a predetermined time after a preceding one of products 26a-26g is used.

In this embodiment, product containment system 24 has a substrate 30 with a plurality of product compartments 32a-32g. Product compartments 32a-32g each have a volume sufficient to receive at least one of the plurality of products 26a-26g, and a compartment opening 36a-36g at a front side 38 of substrate 30 through which products 26a-26g can be moved into and out of product compartments 32a-32g. Substrate 30 also provides a plurality of gas conduits for each product compartment 32a-32g. FIG. 4 shows gas conduits 40a-40f respectively for compartments 32a-32f. Each conduit 40a-40f links each of product compartments 32a-32f to one of a plurality of window chambers 50a-50f. Window chambers 50a-50f are transparent or translucent portions of substrate 30 through which the appearance of one of a plurality of indicators 70a-70f such as gas sensitive indicators can be observed. A film 60 is bound to back side 38 of substrate 30. Film 60 encloses product compartments 32a-32g, conduits 40a-40f and window chambers 50a-50f creating window chamber volumes 52a-52f between film 60 and substrate 30 that are connected to product compartments 32a-32g by way of conduits 40a-40f, respectively.

An optional cover sheet 90 (FIGS. 2-3) is also shown having, in this embodiment, holes 92a-92g that are patterned and sized to allow cover sheet 90 to slide over product compartments 32a-32g until cover sheet 90 is pressed against at least a part of front side 38 of substrate 30, such that product compartments 32a-32g protrude from holes 92a-92g. A back side 96 of cover sheet 90 is typically adhesively bound to front side 38 of substrate 30.

In the embodiment illustrated in FIGS. 2-5, substrate 30 comprises a polymeric material that is impermeable or substantially impermeable to ambient air 80 (FIG. 5) surrounding product containment system 24. Film 60 is made from a thin film of a metallic foil such as an aluminum foil or other metallic foil and is likewise impermeable or substantially impermeable to ambient air 80. Accordingly, when film 60 is bound to front side 38 of substrate 30, film 60 creates a plurality of gas seals 62a-62g (FIG. 3) each sealing one of product compartments 32a-32g against the flow of ambient air 80. Film 60 also seals window chambers 50a-50g and gas conduits 40a-40f against ambient air 80 while creating enclosed environments such as enclosed environment 82a shown in FIG. 5 where gas can flow between connected ones of product compartments 32a-32g, gas conduits 40a-40f and window chambers 50a-50f. Essentially, the product compartments 32a-32g can form sealed cavities that can be arranged in, for example, at least linear array, a matrix pattern or another type of pattern based on the shape of the product containment system.

In other embodiments, thin film 60 can take other forms and comprise, for example and without limitation, a polymeric film or a fibrous material such as paper that is impermeable or substantially impermeable to ambient air 80. Film 60 can have one or more surfaces with one or more layers of additional material thereon. Examples of such additional material include but is not limited to adhesives, primers, sealants, toners, dyes, protective materials, oxygen scavengers and the like. These layers can be applied by way of coating, thermal transfer, or printing for example.

In the embodiment of FIGS. 2-5, indicators 70a-70f are formed on film 60 in indicator portions 74a-74f. Indicator

portions **74a-74f**, in turn are positioned within visible areas **72a-72f** of film **60** that can be observed through window chambers **50a-50f**. In other embodiments indicators **70a-70f** can be formed in whole or in part on window chambers **50a-50f**.

Indicators **70a-70f** have or are made of a gas reactive or sensitive material that changes from a first appearance to a second appearance after a predetermined time after exposure to gasses in ambient air **80**. In the embodiment shown in FIGS. 2-5, the presence of the gas reactive or sensitive material in indicators **70a-70f** causes indicators **70a-70f** to have a first appearance causing indicator portions **74a-74f** to be difficult to visually discriminate from other portions of visible areas **72a-72f**. In this regard, in this embodiment, indicators **70a-70f** can have a first appearance that causes indicator portions **74a-74f** to be identical, consistent with, to match, or correspond to or to complement other portions of visible areas **72a-72f**, so as to limit the extent to which indicator portions **74a-74f** have an appearance that is different from that of other portions of visible areas **72a-72f**.

As will be discussed in greater detail below, when indicators **70a-70f** have a second appearance, indicators **70a-70f** cause indicating portions **74a-74f** to have an appearance that does not match the appearance of remaining portions of visible area **72a-72f**, such as by creating contrast differences between indicating portion **74a** and other portions of visible area **72a**, by creating inconsistent colors, or by changing in any other way to cause the appearance of the indicating portions **74a-74f** to be visually distinct from the appearance of the viewable area.

In other embodiments, indicators **70a-70f** can have a first appearance with indicating portions **74a-74f** appearing visually inconsistent with the appearance of other portions of visible areas **72a-72f**, and a second appearance that is consistent with that of other portions of visible areas **72a-72f**. Other arrangements are also possible.

Exposure of the gas sensitive material in indicators **70a-70f** can cause indicators **70a-70f** to change appearance in any of a number of ways including but not limited to causing a change in the reflectance, absorbency or transmissivity of indicators **70a-70f**. For example, the change in gas sensitive material caused by exposure to ambient air **80** can create color changes, reflection pattern changes, or optical density changes or any other changes that can cause or create a visually distinct difference in the appearance of what is visible to an observer through window chambers **50a-50f**. Additionally, and without limitation, indicators **70a-70f** can have a gas sensitive material that serves as a medium that combines with more than one gas or that cause a combination between more than one gas in ambient air **80** to form combinations that change colors, reflectivities, or transmission characteristics of indicators **70a-70f**. In other embodiments, the gas reactive material can comprise a substrate on which biological agents can grow when supplied with oxygen and/or humidity when exposed to atmospheric air so that the appearance change occurs as a product of the growth of a colony of such biological agents. A wide variety of gas sensitive materials can be used for the purposes described herein and several of these materials are described in greater detail below.

As used in this embodiment, ambient air **80** can be understood to mean atmospheric air including at least nitrogen, oxygen, carbon dioxide and water vapor, and in this embodiment the gas reactive material that is selected to cause indicators **70a-70f** to change from the first appearance to the second appearance after a predetermined exposure to one or more of these gasses.

As is shown in FIG. 5, when substrate **30** and film **60** are joined together a portion of film **60** provides a gas seal **62a** between a portion of film **60** and portions of substrate **30** forming product compartment **32a**, conduit **40a**, and window chamber **50a**. This in turn creates an enclosed environment **82a** within which indicator **70a** is protected from exposure to gasses in ambient air **80** that can cause indicator **70a** to change appearance. Similarly, other gas seals **62b-62g** are formed between portions of film **60** and portions of substrate **30** forming product compartments **32b-32f**, conduits **40b-40f**, and window chambers **50b-50f**. Additionally, a seal **62g** is provided between a portion of film **60** and a portion of substrate **30** forming product compartment **32g**.

Product containment system **24** is of a push through type. Accordingly, cover sheet **90** can provide starting instructions **98** and optionally a section **100** to enter a start date for administering the product as well as the name of the product, which can be printed using conventional printing technologies on cover sheet **90**. Cover sheet **90** can also include instructions to the user such as "Start Here" with an arrow **96** pointing toward product compartment **32a** which contains a first product **26a** in the sequence of products **26a-26f**. This can also be printed on the cover sheet **90** using conventional printing technologies. Arrow **96** also provides the advantage of being an example for the user to observe in order to recognize the subsequent indicators that will appear after the predetermined time period has elapsed. The user, following the instructions can remove product **26a** from product compartment **32a** by pressing product **26a** against thin film **60** to create a disruption **68a** (FIG. 6) in gas seal **62a** through which product **26a** can be removed from product containment system **24**.

In this regard, product compartments **32a-32g** are collapsible and film **60** and seals **62a-62g** are arranged so that a pressure that is sufficient to collapse one of product compartment **32a-32g** is also sufficient to drive products **26a-26g** through seals **62a-62g** respectively. This can be done, for example, by rupturing film **60** at gas seals **62a-62g** or by breaking a bond between film **60** and substrate **30** at gas seals **62a-62g**. Substrate **30**, film **60** and seals **62a-62g** otherwise provide sufficient structural strength to hold products **26a-26g** within product compartments **32a-32g** when exposed to a range of forces that product containment system **24** may be exposed to during incidental contact that arises during manufacture, packaging, retail sale and pre-use transportation to a retailer and to a user.

FIG. 6 shows a top view of the embodiment of product containment system **24** of FIGS. 2-5 immediately after a product **26a** has been accessed. FIG. 7 illustrates a bottom elevation view of product containment system **24** immediately after a product **26a** has been accessed. FIG. 8 illustrates a cutaway view of the product containment system **24** immediately after a product **26a** has been accessed. FIG. 9 illustrates a cross section of the cutaway view of the product containment system **24** immediately after a product **26a** has been accessed. FIGS. 10 and 11 illustrate product containment system **24** at a predetermined time after product **26a** has been accessed.

As is illustrated in FIGS. 6-9, when a product **26a** is accessed, disruption **68a** is formed in seal **62a** that allows ambient air **80** to be exchanged with any gasses in product compartment **32a**. This also allows gasses in ambient air **80** to flow through conduit **40a** to window chamber **50a** by way of conduit **40a**. This begins an exposure of the gas reactive material in indicator **70a** that will cause indicator **70a** to change from a first appearance to a second appearance at a predetermined time after disruption **68a** is formed in seal **62a**.

In this embodiment indicator **70a** is arranged to indicate at least one of the plurality of products **26b-26f** in the predetermined sequence that is to be accessed next. Here, this is done by positioning indicator **70a** and window chamber **50a** proximate to product compartment **32b** in which a next product **26b** in the sequence of products **26b-26g** is contained (FIGS. 6 and 8). It will be appreciated that use of conduits such as conduit **40a**, makes it possible to physically separate the physical location of window chamber **50a** from the physical location of product compartment **32a**, and to position window chamber **50a** in a location that is proximate to product compartment **32b**. In this way compartment **32b** and the remaining compartments **32c-32g** remain sealed from ambient air **80**. This proximity helps to avoid confusion as to which product is to be accessed next and is made possible through the use of conduits **40a-40f**.

Indicators **70a-70f** can also optionally be arranged to supplement the proximity based indication of product compartments **32b-32g** by being patterned to further help to clarify which of product compartments **32b-32g** are to be used next. In the embodiment of FIGS. 2-9 this is done by shaping indicators **70a-70f** in the form of an arrow that is directed toward product compartments **32b-32g**. Similarly, in this embodiment, indicator **70b** is likewise shaped in the form of an arrow that points toward product compartment **32b** and by shaping the remaining indicators in similar fashion. This can help to visually link individual ones of indicators **70a-70f** and individual ones of product compartments **32b-32g** respectively.

In other embodiments, indicators **70a-70f** can also optionally be shaped in other ways to visually link the product compartments. For example, individual ones of indicators **70a-70f** can be patterned to have text or graphic symbols that visually correspond with text and graphic symbols associated with individual ones of product compartments **32a-32g**. In still other embodiments, indicators **70a-70f** can be mapped to correspond to the shapes of distinctly shaped products **26a-26g** or to correspond to distinctly shaped product compartments **32b-32g** such as by providing indicators **70a-70f** that are patterned in distinct shapes that correspond to distinctly shaped ones of product compartments **32b-32g**. Similarly, in other embodiments, a plurality of different colors can be optionally used at each of indicators **70a-70f** that correspond to a plurality of different colors used at each of product compartments **32b-32g**.

It will be appreciated from the description above that the act of accessing one of products **26a-26g** that is stored in product containment system **24** automatically initiates processes that will cause one of indicators **70a-70f** to indicate one of the products **26b-26g** that is to be used next, and will do so only after a predetermined period of time has elapsed. This relieves the user of product containment system **24** from the tasks of determining what product to use next and when it might be necessary to use the product.

In this embodiment, each of products **26b-26g** is to be accessed no sooner than 24 hours after a preceding one of products **26a-26f** has been accessed. Accordingly, indicators **70a-70f** generally maintain a first appearance until about 24 hours after exposure to ambient air **80**. After a 24 hour period of exposure to ambient air **80**, indicator **70a** changes from a first appearance shown in FIGS. 2-9 to a second appearance shown in FIGS. 10 and 11. As is shown in FIGS. 10 and 11, indicator **70a** has a second appearance that is different from the appearance of other portions of visible area **72a** of film **60**. This then provides an observer with an indication that it is now time to access product **26b** which, in this embodiment, is

the next one of products **26b-26g** to be accessed in the sequence of products **26a-26g**.

Similarly, when product **26b** is accessed, indicator **70b** is exposed to ambient air **80** and changes appearance 24 hours later to indicate that it is time to access product **26c**. This process repeats in like fashion after products **26c**, **26d**, **26e** and **26f** are accessed.

There are various ways that product containment system **24** can be used to define the predetermined time between access to one of products **26a-26f** and the change in appearance of an associated one of indicators **70a-70f**.

In some embodiments, the type of gas sensitive material provided in each of indicators **70a-70f** can be used to determine the predetermined time for each of indicators **70a-70f**. For example, certain gas sensitive materials will change appearance at different times even though exposed to the same ambient air **80**. Accordingly, in the embodiment of FIGS. 2-11 indicators **70a-70f** can include gas sensitive materials that are known to transition from a first appearance to a second appearance after about 24 hours of exposure to one or more of the gases in ambient air **80**.

Alternatively, in the embodiment of FIGS. 2-11, indicators **70a-70f** can use gas sensitive materials (such as different gas sensitive materials) that transition from a first appearance to a second appearance at times that are greater than or less than 24 hours of exposure to ambient air **80** but that are treated, processed, patterned, printed, coated, overcoated or applied in ways that reduce the rate of exposure of indicators **70a-70f** to gasses in ambient air; or that accelerate or delay the change in appearance of gas sensitive materials so that such gas sensitive materials cause indicators **70a-70f** to transition from the first appearance to the second appearance after a predetermined period of time. For example and without limitation, the embodiment of FIGS. 2-11 can use gas sensitive materials in indicators **70a-70f** that would cause indicators **70a-70f** to transition from a first appearance to a second appearance in 12 hours when directly exposed to ambient air **80**, where such gas sensitive materials are coated with a material that is semi-permeable to ambient air **80**. Such semi-permeable material can adjust or restrict the rate at which this gas sensitive material is exposed to ambient air **80** so as to delay the change in appearance of indicators **70a-70f** so that indicators **70a-70f** change appearance after 24 hours after exposure to ambient air **80**. Accordingly, the present invention can provide for an adjustment or modification or control of the time or rate at which the indicators **70a-70f** can transition from a first appearance to a second appearance through at least the selection of the gas sensitive material or a coating applied on the gas sensitive material.

Another embodiment of a product containment system **24** is shown in FIGS. 12 and 13. The embodiment of FIGS. 12-13 is substantially similar to that shown in FIGS. 2-11 but includes the addition of a gas scavenger **110** that is positioned between a product compartment **32a** that has an indicator **70a**. The gas scavenger **110** is adapted to absorb one or more of the gasses in ambient air **80** that a gas reactive material in indicator **70a** reacts with to cause a change in appearance of the indicator **70a**. This causes the predetermined time between the creation of disruption **68a** and a time of transition of indicator **70a** to be longer in the embodiment of FIGS. 12 and 13 than in the embodiment of FIGS. 2-11.

In the embodiment of FIGS. 12 and 13, gas scavenger **110** comprises an oxygen scavenging material that is supplied in conduit **40a**. In other embodiments, such a gas scavenger **110** can be positioned in product compartments **32a-32g**, in window chambers **50a-50f** (as shown in, for example, FIG. 15) or on film **60**.

In any of these embodiments, the predetermined time can be adjusted or modified by controlling the intensity of the gas scavenging of the gas scavenger **110** or the capacity of gas scavenger **110** to scavenge gas(es) from ambient air **80**. These factors, in turn, can be controlled by selection of a gas scavenging material to be used in gas scavenger **110** by controlling, for example and without limitation, the amounts, the size, the shapes, the patterns or the surface area of gas scavenging materials in gas scavenger **110**. Accordingly, by proper control of such factors it becomes possible to control the predetermined time between the creation of a disruption such as disruption **68a** and the time at which an indicator such as indicator **70a** transitions from the first appearance to the second appearance. In some examples of this embodiment, the gas scavenger **110** and the gas reactive material in indicator **70a** can be the same material and in such embodiments the gas scavenging material can be positioned in locations that will not be visible to an observer of window chamber **50a** because these areas are located under cover sheet **90**.

As is noted above, in the embodiment of FIGS. **12** and **13**, gas scavenger **110** is an oxygen scavenger. A wide variety of oxygen scavenging materials are available and can be used to form such an oxygen scavenger. These materials can include but are not limited to organic oxygen scavengers such as carbonylhydrazide, diethyl hydroxylamine (DEHA), methyl ethyl ketoxime (MEKO), hydroquinone, or tannin, and inorganic oxygen scavengers such as sodium sulfite and hydrazine.

In still other embodiments, a shape, size, volume, or area of conduits **40a-40f** and window chambers **50a-50f** can be used to control an extent and a timing of an exposure of a particular indicator **70a-70f** to gases in ambient air **80** so as to provide control over the timing of the transition of the indicator **70a-70f** from the first appearance to the second appearance. For example, FIG. **14** shows a top view of a cutaway of one embodiment of a product containment system **24** having a conduit **40a** with a first width **42a** that tapers to a second width **44a**, while FIG. **15**, shows a section view of a product containment system **24** of FIG. **12** having a conduit **40a** that has a first height **46a** at a first position and a second height **48a** at a second position between product compartment **32a** and window chamber **50a**; with the second height **48a** being smaller than the first height **46a**. It will be appreciated that this approach reduces a flow of ambient air **80** into window chamber **50a**. This shapes conduit **40a** to have a greater resistance to the movement of ambient air **80** than conduit **40b** given that conduit **40b** is not illustrated with such features. This therefore increases the amount of time required for indicator **70b** to change from a first appearance to a second appearance after product **26b** is accessed by removing product **26b** from product compartment **32b**, as compared to the amount of time required for indicator **70a** to change from a first appearance to a second appearance following access of product **26a**.

It will be appreciated that size and shape modifications can be made to limit the rate at which ambient air **80** can flow from disruption **68a** to window chamber **50a**, that such modifications can include modifications to product compartments **32a-32g**, to conduits **40a-40f**, to window chambers **50a-50f**, and that other known methods for shaping and sizing air conduits or chambers can be used to provide controlled airflow, so as to control an amount of time between access to a product **26a-26g** in a product compartment **32a-32g**, and a time at which an indicator **70a-70f** that is in a window chamber **50a-50f** that is connected to the holding chamber changes appearance.

It is not necessary that indicators **70a-70f** each change from a first appearance to a second appearance at the same time following exposure to ambient air **80**. For example, an amount of time between an exposure of indicator **70a** to ambient air **80**, and a time at which indicator **70a** changes from the first appearance to the second appearance can be significantly longer or shorter than an amount of time between an exposure of indicator **70b** to ambient air **80**, and a time at which indicator **70b** changes from a first appearance to a second appearance. In this regard, the various techniques described above for controlling the time at which a particular indicator transitions from a first appearance to a second appearance can be used in different ways to cause, for example, indicator **70a** to transition from the first appearance to the second appearance fifteen minutes after product **26a** is accessed, while causing indicator **70b** to transition from the first appearance to the second appearance 24 hours after second product **26b** is accessed. These examples are non-limiting.

It will be appreciated from this that by using product containment system **24** to package products **26a-26g** it becomes possible to form a product containment system **24** with accurate indications of the sequence and relative times at which products **26a-26g** are to be used. Additionally, it will be appreciated that the use of conduits **40a-40f** to separate product compartments **32a-32g** from indicators **70a-70f** enables product containment system **24** to have products **26a-26g** without requiring that products **26a-26g** be arranged in a positional sequence and without requiring special attention to product instructions and labeling.

FIGS. **16** and **17** shows still another embodiment of a product containment system **24** in accordance with the present invention. In this embodiment, product containment system **24** has a gas scavenger **110'** (FIG. **17**) between film **60** and substrate **30**. In this embodiment, the gas scavenging material is applied as a layer on a surface of film **60** that confronts substrate **30** when film **60** is bound to substrate **30**. In this embodiment gas scavenger **110'** further isolates product compartments **32a-32g**, conduits **40a-40f** and window chambers **50a-50f** from gasses in ambient air **80** in areas between product compartments **32a-32g**, conduits **40a-40f** and window chambers **50a-50f**. In this embodiment, gas scavenger **110'** can be printed, coated or otherwise bonded to substrate **30** or to film **60** prior to assembly of product containment system **24**. Such printing or coating can be patterned or uniform. Gas scavenger **110'** can also be provided in a matrix or mixed with adhesives or other bonding agents that help to bond and form seals between substrate **30** and receive **24**.

Optionally gas scavenger **110** or **110'** can be provided in product compartments **32a-32g**, conduits **40a-40f** and window chambers **50a-50f** (for example, see FIG. **15**) to reduce the extent to which any gases in product compartments **32a-32g**, conduits **40a-40f** and window chambers **50a-50f** during manufacture of product containment system **24** can react with gas sensitive materials in indicators **70a-70f** after manufacture but prior to a time at which any of products **26a-26g** are accessed. Further, the presence of such gas scavenger **110** or **110'** in product compartments **32a-32g**, conduits **40a-40f** and window chambers **50a-50f** can also help to control the extent and timing of exposure of gas sensitive materials in indicators **70a-70f** so as to help control when indicators **70a-70f** transition from a first appearance to a second appearance following access of a product contained in one of product compartments **32a-32g** as is generally described above.

A wide variety of gas scavenging materials are known that can be used to form a gas scavenger **110**, **110'**. For example,

oxygen-scavenging material such as those that are described in U.S. Pat. Pub. 2006/0110835A1 "Apparatus For Indicating The Passage Of Time And Method Thereof and Articles Therewith". U.S. Pat. Pub. 2006/0110835A1 describes using an oxygen scavenging material to delay or control the elapsed time interval causing a reduction-oxidation (redox) dye to change color. This approach is also limited to one individual fixed time interval and does not provide an indication of a sequence of individual fixed or variable timed events.

As is described in U.S. Pat. Pub. 2006/0110835A1, suitable oxygen-scavenging materials include the oxygen-indicating tablets sold by Mitsubishi Chemical Company under the trademark, "Ageless®", such as Ageless® E-200 oxygen-indicating tablets. The ultraviolet light activatable polymeric oxygen-scavenging system sold by Cryovac Company as Cryovac OS2000 system, or the ultraviolet light activatable formulation described in PCT published application WO 2004/005424, may also be used. Other suitable oxygen-scavenging materials include tannin, carbohydrazide and the material sold by Completion Products and Services as OS-8, an organic salt that is a non-sulfur-based oxygen scavenger. An ultraviolet light activatable material may be preferred as it offers the advantage of longer shelf life for a time-indicating apparatus because it removes the necessity of storage of the time-indicating apparatus in a non-oxygen environment. Other commercially available oxygen scavenging materials such as oxygen-scavenging additives sold under the brand name of O2Block by NanoBioMatters Industries S.L., Valencia, Spain, can be dispersed directly into the packaging materials. This material is based on surface-modified phyllosilicate clay that is functionalized with active iron to create a naturally sourced and highly efficient oxygen scavenging product.

As noted above, indicators **70a-70f** include gas reactive materials that cause indicators **70a-70f** to change from a first appearance to a second appearance after an exposure to one or more gasses in ambient air **80**. Examples of such gas reactive materials include, those described in U.S. Pat. Pub. 2011/0139655A1 "Indicating Package" which describes an ink, that shows whether the inside of a package has been exposed to air and hence oxygen, by a color change or response to an external stimulus. Similarly, U.S. Pat. Pub. 2010/0221468A1 "Printable Oxygen Sensing Composition" describes an oxygen sensing composition capable of being printed by a variety of printing techniques and that can be used to cause a change in an appearance of an indicator after a period of exposure time to oxygen. U.S. Pat. Pub. 2010/0221468A1 discloses the use of fluorescing dyes for this purpose. As is noted therein, the dye should be capable of fluorescing in a manner proportional to the oxygen content of the atmosphere surrounding it. Thus, for example, the intensity of fluorescence may be proportional to oxygen content, or, and more preferably, the decay of fluorescence may be proportional to oxygen content, as in the prior art. Examples of such dyes include: ruthenium (II), osmium(II), iridium(III), rhodium(III) and chromium ions with ligands, especially alpha-diimine ligands, such as 2,2'-bipyridine, 1,10-phenanthroline, 4,7-diphenyl-1-10-phenanthroline, 4,7-disulphonated-diphenyl-1,10-phenanthroline, 5-bromo-1,10-phenanthroline, 5-chloro-1,10-phenanthroline and other diimine ligands. Examples of these complexes include tris(2,2'-bipyridine)ruthenium(II) salts, tris(1,10-phenanthroline)ruthenium(II) salts and tris(4,7-diphenyl-1-10-phenanthroline)ruthenium (II) salts, especially the chloride described above. Other possible systems include similar palladium(II) and platinum(II) complexes with alpha-diimine ligands. Of these dyes, the tris(4,7-diphenyl-1-10-phenanthroline)ruthenium (II) salts, especially the

chloride is preferred. One or more of these dyes is then immobilized in a polymer matrix having pendant sulphonic or phosphonic groups (the term "sulphonic groups" being used herein to mean sulphonic acid groups or ester or salt groups derived from such sulphonic acid groups and the term "phosphonic groups" being used correspondingly to mean phosphonic acid groups or ester or salt groups derived from such phosphonic acid groups). The polymer used in the present invention may be prepared by copolymerising a first ethylenically unsaturated compound, e.g. an acrylic monomer or oligomer, with a second ethylenically unsaturated compound, this one containing one or more sulphonic or phosphonic groups. Provided the acrylic monomer or oligomer and the sulphonic or phosphonic group-containing compound are copolymerisable, there is no particular restriction on them. U.S. Pat. Pub. 2006/0110835A1 also describes the use of dyes that undergo a reduction-oxidation (redox) dye to change color. Examples of such dyes include leucomethylene blue, indigo carmine, Ciba Scarlet B. G., Cibanone Yellow, sodium anthraquinone beta-sulfonate, may be used. The weight of the reduced redox dye disposed in the receptacle having a surface area of approximately four square inches (4 in.sup.2; 6.45 cm.sup.2) is preferably in the range from 0.025 mg to 200 mg, and more preferably in the range from 0.025 mg to 1 mg. U.S. Pat. Pub. 2006/0110835A1 also cites a Cibanone Yellow dye as a preferred redox dye. The reduced form of this dye gives a perceived initial color as intense blue or red-orange (depending upon the ratio of the components of the preferred reducing agent, to be discussed). The perceived final color of the oxidized form of this dye is yellow. This approach is also limited to one individual fixed time interval and does not provide an indication of a sequence of individual fixed or variable timed events.

Other examples include materials prepared by Andrew Mills, as described in the article, "Oxygen indicators and intelligent inks for packaging food", The Royal Society of Chemistry, 2005, Chemical Society Reviews, Chapter 34, Pages 1003-1011, who has developed an irreversible solvent-based blue ink, which upon activation with UV light, loses all its color and becomes oxygen sensitive; it will only gain its original color upon exposure to oxygen.

An advantage of the oxygen ink over most of the traditional methods for detecting oxygen are that it is cheap and easy to use, especially as it relies on a color-change detectable by the human eye. Solvent-based inks such as these may also be easier to print on the common polymers used in food packaging. Other examples of materials can be found in: A. Mills, C. Thommons, R. Bailey, M. C. Tedford Crilly, "UV-Activated Luminescence/Colourmetric O₂ Indicator" International Journal of Photoenergy, Article ID 547301, 2008, S-K. Lee, A. Mills and A. Lepre "An intelligence ink for oxygen," Chemical Communications, No. 17, pp. 1912-1913.

FIG. 18 illustrates one embodiment of a method for manufacturing a product containment system **24** in accordance with the present invention. FIG. 19 illustrates one embodiment of a product containment system manufacturing line **220** in accordance with the present invention that can be used to manufacture a product containment system **24** and that can be used, for example, in the performance of the method of FIG. 18. FIG. 20 provides an assembly view of one embodiment of a product containment system **24** made according to the method of FIG. 18 using the product containment system manufacturing line **220** of FIG. 19.

According to the method of FIG. 18 (step **150**), a substrate **30** is provided having a plurality of product compartments **32a-32g** each with a volume sufficient to receive at least one of a plurality of products **26a-26g**, with a plurality of gas

conduits **40a-40f** each leading from one of product compartments **32a-32g** to one of a plurality of window chambers **50a-50f**. Window chambers **50a-50f** each have a window volume. The provided substrate **30** can take the form of any embodiment having such features. For convenience only, the 5
embodiments described with reference to FIGS. **18**, **19**, and **20** will be described as using the embodiment of substrate **30** illustrated in FIGS. **2-11**. Accordingly, as is illustrated in FIG. **20** and described above, in this embodiment, substrate **30** has a plurality of product compartments **32a-32g**, a plurality of window chambers **50a-50f** and a plurality of conduits **40a-40f** (not shown in FIG. **20**) that connect individual ones of product compartments **32a-32g** to respective ones of window chambers **50a-50f** as is described and shown above in greater detail with reference to FIG. **2-11**.

Substrate **30** can be provided in a variety of ways, such as by fabrication, assembly or other known techniques for forming a substrate **30** or by positioning prefabricated or pre-assembled substrates for use in forming a product containment system **24**.

The embodiment of product containment system manufacturing line **220** shown in FIG. **19** illustrates one example of one way in which a substrate **30** can be provided. In this embodiment, product containment system manufacturing line **220** has a powered conveyor **222** and a source of substrates **224** that supplies substrates **30** to powered conveyor **222**. In this embodiment source of substrates **224** comprises a supply **230** of a formable film **234** and a molding station **240**. In this embodiment, formable film **234** is thermally formable and is supplied in the form of a continuous web that is wound and stored on roller **232** and drawn therefrom as needed. Examples of such thermally formable films can include but are not limited to polymeric and other organic plastic films such as polyesters and polystyrenes. Formable film **234** is then guided through an optional pre-heating station shown here as heated roller **238** and is then supplied to molding station **240**.

In this embodiment, molding station **240** thermoforms and optionally sizes formable film **234** using conventional techniques for hot molding such as by using a heated two-part 40
form or using a vacuum-forming device to form product compartments **32a-32g**, window chambers **50a-50f** and gas conduits **40a-40f** as is described in greater detail elsewhere herein. Examples of a thermally formable film **234** include polyvinyl chloride (PVC) which has excellent thermoforming and optical transparency properties and is used to provide the basic structure of the thermoformed blister pack tray, but is a poor barrier against moisture and oxygen. PVC can be combined with other materials via co-extrusion or lamination to form multi-layer barrier films. For example, PVC can be laminated to polychlorotrifluoro ethylene (PCTFE) to obtain an oxygen and moisture barrier. In addition, PVC can be coated with polyvinylidene chloride (PVDC) known by the trade name "Saran" or laminated to PCTFE or cyclic olefin copolymers (COC) to increase the barrier properties.

In one embodiment, ultraviolet (UV) light can be provided to the gas sensitive indicators **70a-70f** by way of window chambers **50a-50f** during production of product containment system **24**. This UV light can be used to make gas sensitive materials in indicators **70a-70f** become reactive to gasses in ambient air **80** so that predetermined times between exposure of indicators **70a-70f** to ambient air **80** after products **26a-26g** are accessed are maintained despite any exposures. Alternatively, indicators **70a-70f** can be provided with a temporary barrier to exposure to ambient air to prevent reaction of indicators **70a-70f** during assembly of product containment system **24**.

In other embodiments, formable film **234** can comprise a cold formable film such as an aluminum-based laminate film that can be cold stamped or drawn to form substrates **30** having the desired arrangement of product compartment **32a-32g**, window chambers **50a-50f** and gas conduits **40a-40f** as is generally described above under certain circumstances. The use of a cold formable film **234** of this type can provide a highly effective barrier against water and oxygen but lacks the transparency of thermoformed plastics.

Products **26a-26g** are positioned in product compartments **32a-32g** (step **152**). Product containment system manufacturing line **220** illustrates one, non-limiting method for positioning products **26a-26g** in product compartments **32a-32g**. As is shown in the embodiment of FIG. **19**, a product dispenser **250** distributes products **26a-26g** from a dispenser supply **252**. A variety of conventional sources of product dispensers can be used for this purpose. In this embodiment, product dispenser **250** takes the form of a bulk dispenser of products **26a-26g**. As shown in the example, the same product 20
26a-26g is used in each of product compartment **32a-32g**. However, where more than one different type of product **26a-26g** is loaded into each of product compartments **32a-32g**, more complex dispensing equipment can be used. For example, pick and place robotic or other forms of automatic assembly equipment known in the art can be used for this purpose. Additionally, dedicated dispensing tooling adapted to deliver different products can also be used to enable high-volume production of product containment system **24**.

Film **60** is then provided (step **154**). There are a number of ways in which film **60** can be provided. In the embodiment shown in FIG. **19**, film **60** is supplied in the form of a continuous web that is stored on a spool **260** and supplied as needed. In other embodiments, film **60** can be provided in other convenient forms including sheet forms.

Gas sensitive indicators **70a-70f** are provided in areas that will be aligned with window chambers **50a-50f** after film **60** is joined to the substrate **30** (step **156**). In the embodiment of FIGS. **18-20**, indicators **70a-70f** are shown being provided on film **60**. In this regard, an indicator application system **264** prints, transfers, adheres or otherwise applies materials forming gas sensitive indicators **70a-70f** to film **60**. In this embodiment, indicator application system **264** has a printhead **266** that prints indicators **70a-70f** on a surface of film **60** that confronts substrate **30**. Printhead **266** can comprise, for example and without limitation, an inkjet printhead, a thermal printhead, an electrophotographic printhead, or a contact printing plate or system. In other embodiments, indicator application system **264** can comprise a system for transferring a structure such as a film, fabric or sticker to film **60**.

Substrate **30** and film **60** are sealed together with products **26a-26g** and gas sensitive indicators **70a-70f** therebetween and with gas sensitive indicators **70a-70f** aligned with window chambers **50a-50f** so that the appearance of gas sensitive indicators **70a-70f** can be observed through window chambers **50a-50f** (step **158**). This encapsulates indicators **70a-70f** between substrate **30** and film **60** to isolate indicators **70a-70f** from ambient air **80**. In addition, in other embodiments window chambers **50a-50f** can allow ultraviolet or other light to pass through substrate **30** to the gas sensitive indicators **70a-70f** during production of the Push-Through-Packs on a blisterline to initiate the gas sensitive reaction where indicators **70a-70f** require such exposure.

In the embodiment of FIG. **19**, a film application system **280** is used to apply film **60** to form gas seals for each of the product compartments **32a-32g** and any associated ones of conduits **40a-40f** and window chambers **50a-50f**. Film **60** can be bound to substrate **30** using pressure and heat to weld,

bond or fuse or otherwise form a seal between substrate **30** and film **60**. In the embodiment that is illustrated, film application system **280** applies heat and pressure to film **60** to form a bond between film **60** and substrate **30** that sealing encloses each of product compartments **32a-32g**, any associated conduits **40a-40f** and window chambers **50a-50f**.

In the embodiment of FIG. **19**, product containment system manufacturing line **220** has indicator application system **264** and film application system **280** closely positioned to limit the amount of time that film **60**, and indicators **70a-70f** thereon are exposed to ambient air **80** before indicators **70a-70f** are enclosed between substrate **30** and film **60**. In other embodiments, product containment system manufacturing line **220** can be operated in an environment that has low concentrations of gasses in ambient air **80** to which gas sensitive materials in indicators **70a-70f** react. This can be done, for example, by providing a low pressure atmosphere around film **60** between printing of indicators **70a-70f** and sealing assembling film **60** to substrate **30** in areas between the provision of indicators **70a-70f** on film **60** and the joining of film **60** to substrate **30**. This can also be done by creating an increased concentration of gasses that do not interact with gas sensitive materials in indicators **70a-70f**.

A printing system **270** prints text, graphics and other information on film **60** and a dryer **290** directs heat or airflow at film **60** when printing by printing system **270** involves the use of types of printing that require drying.

One or more additional films **310** can also be supplied for purposes such as protecting printing made on film **60**, enhancing the gas bather capabilities of film **60**, or for aesthetic reasons. Film **310** is then bonded to film **60** using a bonding system **312** that creates such a bond using heat and pressure or other activating energies to induce bonding of film **310** to film **60**.

After assembly, substrate **30**, film **60** and optionally film **310** are then measured and cut by an inline cutter **320** and advanced by an output conveyor **330** to a collection bin **340**.

Optionally, a cover sheet **90** can be supplied and joined thereto (step **162**). Cover sheet **90** can be created using conventional printing and cutting systems **350** including but not limited to conventional printers such as inkjet printers, electrophotographic printers, other toner printers, and contact printers and conventional paper punch or laser cutting systems. Sheets **90** can be joined to substrate **30** using conventional assembly and bonding equipment **360** that receives assembled product containment systems **24** and adds optional cover sheets **90**. Conventional positioning systems such as conveyors and other known material handling techniques can be used to position product containment systems **24** and cover sheets **90** relative to each other. Similarly, assembly bonding equipment **360** can include adhesive applicators or activators or thermal systems that can cause heat bonding of cover sheet **90** to substrate **30**.

Also shown in FIG. **18** (Step **160**) is an optional adjustment step, in which substrate **30** or film **60** are resized to adjust exposure rates of at least one of the indicators **70a-70f**. FIG. **19** shows one embodiment of an optional resizing system **400** that can be used to resize substrate **30** for such a purpose. In this embodiment, resizing system **400** comprises a shaping element such as a hot or cold form that can be used to resize any of conduits **40a-40f** or window chambers **50a-50f** in order to control a rate at which ambient air **80** can flow to indicators **70a-70f** located in such window chambers **50a-50f**. This allows a source of substrates **30** to supply substrates **30** having uniformly shaped conduits **40a-40f** and/or window chambers **50a-50f** while still allowing the substrates to provide different predetermined delays between a time at which gas

seals associated with different ones of a sequence of products are disrupted, and a time at which indicators for the next product are to change appearance. That is, a uniform substrate **30** can be provided that can be modified to provide different predetermined delays for different ones of products assembled thereto. Such modifications can occur after manufacture.

In one embodiment, where substrate **30** comprises a heat formable film, optional resizing system **400** uses a heater **410** and an actuator **420** to advance a surface **430** into contact with one or more of conduits **40a-40f** of substrate **30** to adjust the shape of a conduit **40a-40f** to provide a controlled resistance to ambient air flow into individual ones of viewing chambers **50a-50f**. By causing different ones of conduits **40a-40f** to have different resistances to the flow of ambient air **80** into different viewing chambers **50a-50f**, each of indicators **70a-70f** can be made to have a different rate of exposure to ambient air **80** and therefore to change appearance at different times. This can be done, for example, by modifying a substrate **30** having identically sized and shaped conduits **40a-40f** so that, for example, one of conduits **40a-40f** has a different size or shape as is discussed above in greater detail with respect to FIGS. **14** and **15**. It will be appreciated that where film **60** can reliably retain a modified shape, resizing system **400** can be repositioned to modify film **60** in the area of one or more conduits **40a-40f** or window chambers **50a-50f** to create increased resistance to flow in like fashion with similar results.

If cover sheet **90** is made of paper board, card board, or the like, or is otherwise opaque it is provided with cover sheet apertures **94a-94f** (FIG. **2**) that are aligned with each of window chambers **50a-50f** so that visible areas **72a-72f** can be observed.

In other embodiments, indicators **70a-70f** can be printed on substrate **30** against window chambers **50a-50f**. For example, FIG. **21** illustrates an embodiment of a product containment system manufacturing line **220** having an indicator application system **264** that is positioned proximate to substrate **30** to apply indicators **70a-70f** directly to substrate **30** and that does so in window chambers **50a-50f**. FIGS. **22** and **23** illustrate a cut away view of one example of such an arrangement of a product containment system **24**. As can be seen here, indicator **70a** is formed in an indicating portion **74a** that is within a visible area **72a** that can be observed through window chamber **50a**.

In another alternative embodiment, gas sensitive indicators **70a-70f** are printed on substrate **30** by replacing the paper board cover sheet **90** with a mounting card made of a transparent gas barrier material like the product tray and sealed to the top surface of the substrate **30**. Ink printing and/or additional labels can be used to obscure portions of the top surface, provide text and/or graphics, and to provide instructions. The third position in the sequence is shown with un-deployed gas sensitive indicator **70a-70f**, which will become visible through aperture **94** and window chamber **50a** after a predetermined amount of time after the product **26a** in product compartment **32a** has been removed by disrupting the gas seal **62**.

FIG. **24** is a cut away view of another embodiment of a product containment system **24**. FIG. **24** illustrates a product containment system **24** after a product (not shown) in product compartment **32a** has been removed creating a disruption **66a** that allows ambient air **80** into a conduit **40a** (shown in phantom) that is linked to a window chamber **50a** and a window chamber **50b**. FIG. **24** illustrates this embodiment of product containment system **24** at or after a predetermined period of time when both of products **26b** and **26c** are to be

accessed and at which indicators **70a** and **70b** have a second appearance indicating that it is time to access products **26b** and **26c**.

In a feature of the invention it is understood that gasses such as hydrogen can be found in ambient air **80** and that it is both difficult and expensive to seal against penetration of hydrogen. However, hydrogen comprises a very small component of ambient air **80** and may not have a meaningful reaction with any of the gas reactive materials used to form indicators **70a-70f**. Accordingly, a seal against ambient air **80** provided by or between substrate **30** and film **60** may not be completely impervious to all atmospheric gases while still functioning in accordance with this or other embodiments described herein.

In other embodiments, the use of conduits **40a-40f** can also enable product containment system **24** to have physical arrangements of products **26a-26g** that are not sequential while linking individual product compartments **32a-32f** to indicators **70a-70f** that are not immediately proximate to product compartments **32a-32f** to which they are linked.

The invention has been described in detail with particular reference to certain preferred embodiments thereof, but it will be understood that variations and modifications can be effected within the spirit and scope of the invention.

What is claimed is:

1. A containment system for a plurality of products that are to be accessed in a predetermined timed sequence, the containment system comprising:

a substrate with a plurality of product compartments, each of said product compartments having a volume sufficient to receive at least one of a plurality of products, said substrate further including a plurality of atmospheric gas conduits each leading from one of the product compartments to a gas sensitive indicator window chamber;

a plurality of gas sensitive indicators having a gas reactive material that changes appearance at a predetermined time after exposure to ambient air, said gas sensitive indicators being located within a gas sensitive indicator window chamber; and

a plurality of gas seals each sealing one of the plurality of the product compartments against atmospheric gases so that disrupting the gas seal to access a product in the product compartment allows atmospheric gas to enter the product compartment and from there to flow through one of the plurality of atmospheric gas conduits to expose at least one of the gas sensitive indicators, the one gas sensitive indicator exposed to ambient air being arranged to change appearance in a manner that indicates at least one next product in the predetermined sequence to be accessed after the predetermined time after exposure has elapsed.

2. The containment system of claim 1, wherein the predetermined time after exposure is substantially consistent for all of the gas sensitive indicators.

3. The containment system of claim 1, wherein at least two of the gas sensitive indicators have at least one of a different material, a different coating or a different pattern of application to cause the predetermined time after exposure for at least two of indicators to be different.

4. The containment system of claim 1, wherein at least one of the conduits has at least one of a different size and a different shape than the other conduits to create resistance in a flow of the ambient air from one of the product compartments to which said at least one conduit is connected to one of the window chambers to which the at least one conduit is connected to cause the predetermined time for at least one of the indicators to be different.

5. The containment system of claim 1, further comprising an oxygen scavenger between at least one of the product

compartments and one of the indicators in one of the window chambers that is linked to the at least one product compartment to reduce the rate at which the one of the indicators is exposed to ambient air so as to extend the predetermined time.

6. The containment system of claim 1, wherein the gas reactive material is activatable to become gas sensitive after exposure to ultraviolet light, and wherein the window chamber allows sufficient ultraviolet light to pass through to the gas reactive material to allow the gas reactive material to be made gas sensitive.

7. The containment system according to claim 1, wherein at least one of said gas sensitive indicators further includes a semi-permeable material coated on said gas reactive material to adjust the time at which the gas reactive material changes appearance after exposure to ambient air.

8. The containment system according to claim 1, wherein at least one of a type of the gas reactive material or a coated material on the gas reactive material determines the time at which the gas reactive material changes appearance after exposure to ambient air.

9. The containment system according to claim 1, wherein a size or shape of at least one of said plurality of atmospheric gas conduits can be modified to adjust a rate of the gas flow through the one of the plurality of atmospheric gas conduits.

10. A containment system for a plurality of products that are to be accessed in a timed sequence, the containment system comprising:

a plurality of product compartments, each of said product compartments being adapted to hold at least one of said plurality of products;

a plurality of gas sensitive indicators adapted to change appearance after exposure to ambient air, at least one of said gas sensitive indicators being located within a gas sensitive indicator window volume; and

a plurality of atmospheric gas conduits each leading from one of the product compartments to one of said gas sensitive indicator window chambers, such that an exposure of one of said product compartments to gain access to a product in said one product compartment allows atmospheric gas to enter the product compartment and from there to flow through at least one of the plurality of atmospheric gas conduits that leads from said exposed product compartment to expose at least one of the gas sensitive indicators, the one gas sensitive indicator exposed to ambient air being arranged to change appearance in a manner that indicates that a next product in the timed sequence is to be accessed.

11. The containment system according to claim 1, further including a cover sheet providing instructions to a user pertaining to how to use the containment system.

12. The containment system according to claim 1, wherein the gas sensitive indicators are symbols, characters, images, or messages that become visible at the predetermined time after exposure to ambient air.

13. The containment system according to claim 1, wherein the product is a pill, capsule or tablet.

14. The containment system according to claim 1, wherein the product compartments are arranged in a linear array or matrix array pattern.

15. The containment system according to claim 14, wherein the gas sensitive indicator connected to a particular product compartment by one of the atmospheric gas conduits is positioned in proximity to a next product compartment in the linear array or matrix array pattern.