

W. E. DAWSON & R. McALPINE.
 ALARM FOR CASH BOXES.
 APPLICATION FILED SEPT. 11, 1908.

1,002,232.

Patented Sept. 5, 1911.

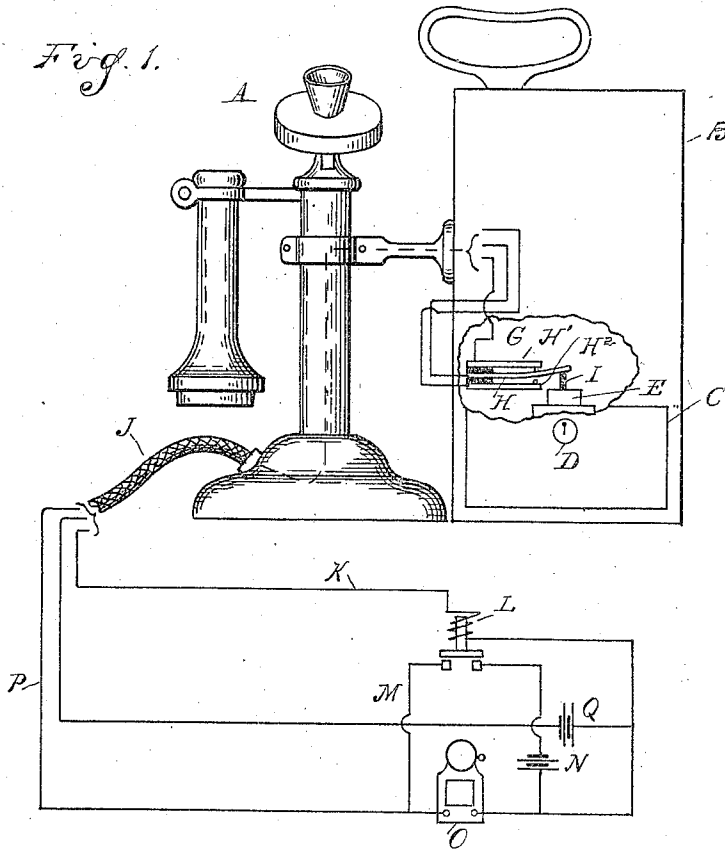

Fig. 2.

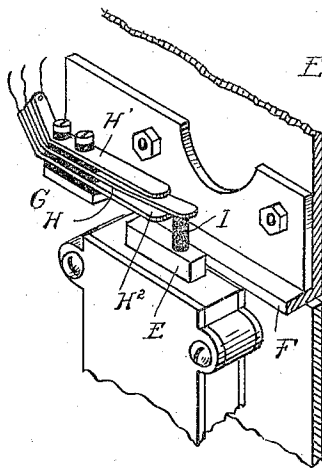
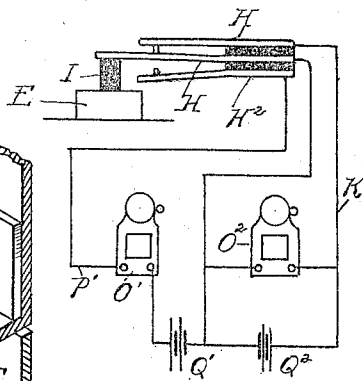

Fig. 3.



Witnesses
 Nellie Kinella
 James P. Barry

Inventors
 William E. Dawson
 Robert M. Alpine

By *Whitcomb Hubert Whitcomb*
 Attys.

UNITED STATES PATENT OFFICE.

WILLIAM E. DAWSON AND ROBERT McALPINE, OF DETROIT, MICHIGAN, ASSIGNORS OF ONE-FOURTH TO WILLIAM D. SOUTHWICK AND ONE-FOURTH TO HARRY J. BOOTH, BOTH OF DETROIT, MICHIGAN.

ALARM FOR CASH-BOXES.

1,002,232.

Specification of Letters Patent.

Patented Sept. 5, 1911.

Application filed September 11, 1908. Serial No. 452,623.

To all whom it may concern:

Be it known that we, WILLIAM E. DAWSON and ROBERT McALPINE, citizens of the United States of America, residing at Detroit, in the county of Wayne and State of Michigan, have invented certain new and useful Improvements in Alarms for Cash-Boxes, of which the following is a specification, reference being had therein to the accompanying drawings.

The invention relates to alarms for cash boxes and is more particularly designed for use in connection with telephone instruments at pay stations.

It is usual to provide telephone instruments at pay stations with a cash box connected therewith into which the toll for the use of the instrument is placed by the user. As the instruments are frequently placed inside of a cabinet or booth opportunity is afforded for the robbing of the box by the thief in comparative concealment. At other stations the instrument is placed on a desk or counter but is usually provided with a cord connection which forms the sole means of attachment. It is therefore only necessary for the thief to pick the cord and to then carry the instrument off bodily—cash box and all.

It is the object of the present invention to provide an effective guard or alarm which will immediately indicate any unlawful tampering with the instrument.

To this end the invention consists in the peculiar construction and arrangement of an electric alarm guarding the cash drawer of the instrument, and further in the means by which the cutting of the circuit or the detachment of the instrument will also sound the alarm.

The invention still further consists in the peculiar construction, arrangement and combination of parts as hereinafter set forth.

In the drawings—Figure 1 is an elevation of the telephone instrument and cash box indicating diagrammatically the alarm circuits; Fig. 2 is a perspective view of the bolt for the cash drawer with the circuit closer for the alarm in operative connection therewith. Fig. 3 is a diagram illustrating a modified arrangement of the electric circuits.

A is the telephone instrument which is

provided with a cash box B, having a drawer C guarded by the lock D. This lock, as shown in Fig. 2, comprises a bolt E which, when projected, extends adjacent to a flange on the inside of the cash box, which flange forms a keeper for the bolt and prevents the opening of the drawer.

Adjacent to the bolt E is arranged a circuit closer G. This preferably consists of a plurality of cooperating contacts H, one of which is operated by the bolt E through the medium of an insulator pin or block I. The arrangement is such that the retracting of the bolt will cause the circuit closer to set in operation the alarm either through the closing or opening of an electric circuit. I preferably employ a double guard circuit under the control of the circuit closer G, one circuit being normally open and the other normally closed. Thus, as shown, the movable contact H is held when the bolt E is projected against the contact H' which closes one electric circuit, while in the same position the movable contact H is separated from a second cooperating contact H² whereby a second electric circuit is opened. Thus the withdrawal of the bolt E will cause the sounding of the alarm through the agency of either or both of these electric circuits, and if one is rendered inoperative the other will still be effective.

As illustrated in Fig. 1, the telephone instrument is provided with a cord connection J, which forms both the electrical and mechanical connection between the instrument and the line. With such a construction the conductors of the alarm circuit are also passed through the cord J. Thus the severing of this cord J, while rendering the open circuit inoperative, will nevertheless sound the alarm by the opening of the normally closed circuit. As illustrated, the normally closed circuit K includes a relay or electromagnetically controlled circuit closer L which controls a local circuit M, including the battery N and alarm bell O. The normally open circuit P also controls an alarm bell and, as indicated, the same bell O is operated by both circuits, and by a distinct battery Q. It is therefore apparent that the device cannot become inoperative through the failure of either of the batteries N or Q, as in the former case the relay L will be operated to close the circuit M, which

will operate the bell O, and in the latter case this bell will be operated by the closing of the circuit P from the battery Q.

Although we have illustrated an instrument in which the electric and mechanical connections are formed through the cord J, it is obvious that the alarm may also be applied to instruments secured in fixed positions, and that with either construction the alarm will be sounded both upon the tampering with the drawer and by the severing of the electric connections. Moreover, in each case, the electric conductors of the alarm circuit may be indistinguishably associated with the regular electric connections for the telephone instrument so that it is impossible to prevent the sounding of the alarm by first cutting or otherwise rendering the alarm circuit inoperative. This is particularly true in cases where the cord connection, the several conductors of the telephone and alarm circuits are so intertwined as to be indistinguishable.

In Fig. 3 a modified arrangement of the electric circuits is illustrated, in which Q' is a battery for the normally open circuit P' and Q² is a battery for the normally closed circuit K'. The bell O² is permanently connected into the circuit K', but the contacts H and H' close a shunt in this circuit whenever the bolt E is projected thereby preventing the operation of the bell O². When this shunt is open the bell O² will be set in operation and at the same time the closing of the circuit P' will set into operation a second bell O'.

What we claim as our invention is:

1. The combination with a telephone instrument and a flexible cord for mechanically and electrically connecting said instrument to its station, of an electric alarm having a portion of its circuit passing through said cord and operated upon the severance or detachment of said cord.
2. The combination with a telephone instrument, of an electric alarm for guarding said instrument having its circuit indistinguishably associated with the electric connections of said instrument.

3. The combination with a telephone instrument and a flexible cord for mechanically and electrically connecting said instrument to its station, of a cash box for said instrument, a lock for said cash box, an electric alarm operatively connected to said lock having a portion of its circuit passing through said cord, and means for operating said alarm upon the unlocking of said lock or the severance of the cord.

4. The combination with a telephone instrument and a flexible cord for mechanically and electrically connecting said instrument to its station, of a cash box for said instrument, a lock for said box, an arm connecting the cash box to the instrument, an electric alarm operatively connected to said lock, having a portion of its circuit passing through the cord and said arm, and means for operating the alarm upon the unlocking of the lock or the severance of the cord.

5. The combination with a telephone instrument and its electrical connections, of a cash box connected to said instrument, a lock for said box, an alarm operatively connected with said lock having its circuit indistinguishably associated with the electrical connections of the instrument, and means for operating said alarm upon the unlocking of said lock or the detachment of said instrument.

6. The combination with a telephone instrument and a flexible cord forming the mechanical and electrical connections between the instrument and its station, of an electric alarm having a portion of its circuit passing through said cord whereby said connections are indistinguishably associated with the cord, said alarm being operated upon the severing or detachment of the cord.

In testimony whereof we affix our signatures in presence of two witnesses.

WILLIAM E. DAWSON.
ROBERT McALPINE.

Witnesses:

NELLIE KINSELLA,
HARRY W. GALVIN.