

M. J. AND A. ROTH.
 SCREEN FRAME.
 APPLICATION FILED MAR. 24, 1920.

1,363,921.

Patented Dec. 28, 1920.

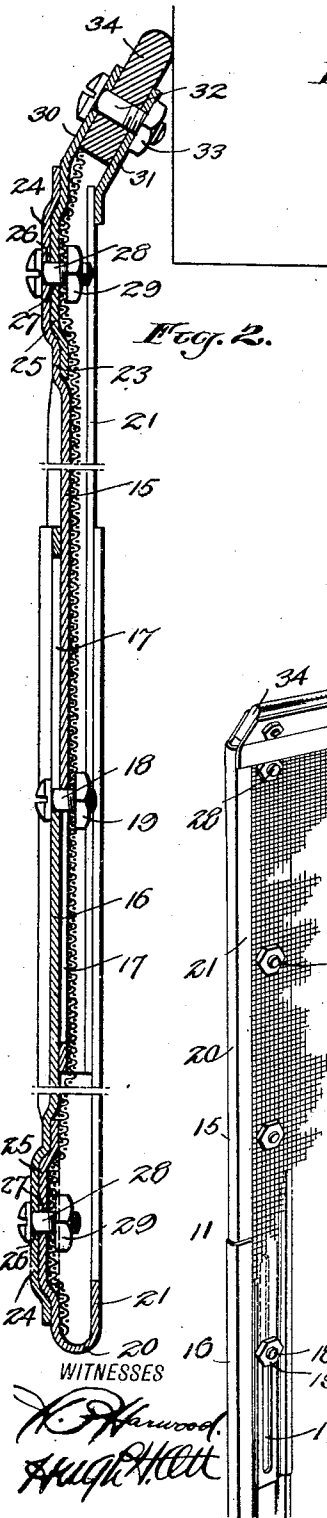

Fig. 1.

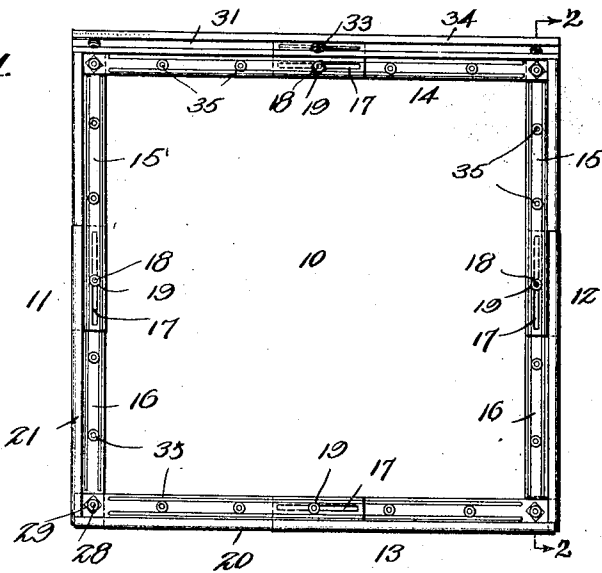

Fig. 2.

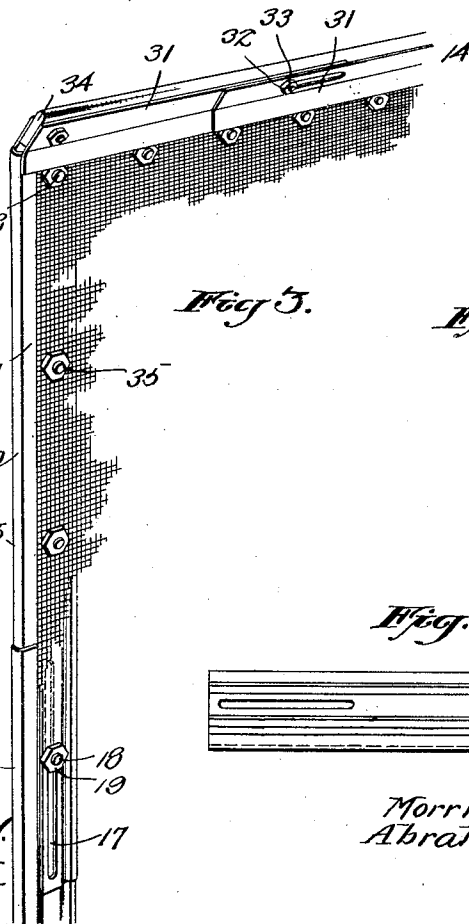

Fig. 3.

Fig. 4.

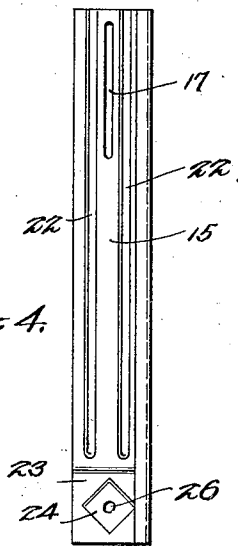
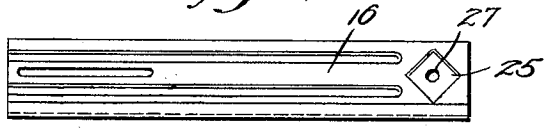

Fig. 5.



WITNESSES
R. J. Harwood
August Helt

INVENTORS
Morris J. Roth
Abraham Roth
 BY
Munn & Co
 ATTORNEYS

UNITED STATES PATENT OFFICE.

MORRIS J. ROTH, OF CORONA, AND ABRAHAM ROTH, OF EAST ELMHURST, NEW YORK.

SCREEN-FRAME.

1,363,921.

Specification of Letters Patent. Patented Dec. 28, 1920.

Application filed March 24, 1920. Serial No. 368,299.

To all whom it may concern:

Be it known that we, MORRIS J. ROTH and ABRAHAM ROTH, both citizens of the United States, and residents, respectively, of the city of New York, Corona and East Elmhurst, borough of Queens, county of Queens, and State of New York, have invented a new and Improved Screen-Frame, of which the following is a full, clear, and exact description.

This invention relates to screens and has particular relation to an adjustable screen frame for windows.

Various frame structures have been designed heretofore for the purpose of rendering the width of the same adjustable to windows of different widths and while the same have been found practical to some extent, many objectionable features have been experienced.

The principal object therefore of the present invention is to perfect an adjustable screen frame by providing a structure which is adjustable both in its width and height.

Another object in view is to construct an adjustable screen frame provided with means which renders the application of the screen fabric thereto, an extremely simple and expeditious task.

A further object of the invention is to provide in combination with an adjustable screen frame means adapted to co-act with the window structure which renders the screen positively proof against the entrance of insects.

A still further object in view is to provide a strong, durable and efficient structure which is inexpensive to manufacture and assemble, and which is readily adjustable to windows of various dimensions.

With the above recited and other objects in view, some of which will be more readily apparent hereafter, reference is made in the following specification to the accompanying drawings forming a part of this application and in which—

Figure 1 is a front view of the frame with the screen fabric removed.

Fig. 2 is a vertical sectional view thereof through taken approximately on the line 2—2 of Fig. 1.

Fig. 3 is a fragmentary perspective view.

Figs. 4 and 5 are detail front elevations of the frame elements.

Referring to the drawings by characters

of reference which denote like parts throughout the several views thereof, the frame in its entirety is designated by the numeral 10 and the same consists of the side rails 11 and 12 and the end rails 13 and 14. All of the rails are of substantially identical construction and each consists of relatively adjustable members 15 and 16 which are preferably formed of sheet metal and provided adjacent their inner extremities with longitudinal slots 17 through which is adapted to be passed a securing element in the nature of a bolt 18 upon which is threaded a nut 19, which serves to retain the members 15 and 16 in their relatively adjusted positions. The outer longitudinal edge of each of the members of the side rails and the lower end rails is provided with an upwardly extending marginal flange 20 having an inturned extremity 21 arranged parallel to the body portion of the member. The members are provided with longitudinal strengthening ribs 22 extending from the inner connected extremity and terminating at a point short of the outer free end of the member. The ribs 22 of the member 15 are designed to co-act with the ribs 22 of the member 16 in order to brace the connected ends against relative lateral displacement. The free extremity of each of the members 16 of the side rails 11 and 12 is offset as at 23 and provided with a rectangular depression 24 which is designed to constitute a socket for the reception of a similarly formed boss 25 provided on the abutting face of the free extremity of each member of the rails 13 and 14. The depressed portion 24 is provided with a central aperture 26 and the depressed portion 25 with a central aperture 27 which are designed to register when the boss is arranged within the depression and through which the securing element in the nature of a bolt 28 is passed and secured in place by means of a nut 29. When the boss 25 is arranged in the depression and the bolt passed therethrough and secured to retain the same in place the proper relative angularity of the side and end rails is maintained. Each of the members of the upper end rail 14 is provided with an angularly disposed extension 30 in lieu of the marginal flanges 20 with which the side rails and lower end rail are provided. A strip 31 is provided and secured in spaced parallel relation to the extension

30 by means of a securing bolt 32 having a nut 33. A resilient packing strip or a gasket 34 is clamped between the extension 30 and the strip 31 and is designed to contact and co-act with the lower rail of the window sash to seal the space between the screen and the sash. The lower extremity of the strip 31 is disposed at an angle to the main body portion and lies parallel with the main body portion of the rail member to provide a housing for the upper extremity of the screen fabric. The screen fabric is secured to the frame members by means of the bolts 18, 28 and additional bolts 35.

15 By the construction heretofore described, it will be seen that an inexpensive screen is provided which is adjustable to suit window openings of various dimensions. The structure permits of the ready removal and application of the screen fabric thereto with means for covering the raw edges of the fabric to prevent the contact of said edges with exterior objects and to present a neat appearance. The packing strip or gasket and its arrangement with respect to the frame provides a means for sealing the space between the upper edge of the screen and the window sash in order to exclude possible entry of insects therebetween.

30 In order to reduce the width of the frame it is only necessary to loosen the nut 32 and the nuts 19 and cut off a portion of the packing strip or gasket and the screen fabric. When it is desired to increase the width of the frame, it is of course understood that a new packing or gasket 34 and a new piece of screen fabric is necessary.

40 While there has been illustrated and described a single and preferred form of the invention, it is understood that variations and changes which fall within the scope of the appended claims and do not depart from

the spirit of the invention may be resorted to when found desirable.

Having thus described our invention, 45 what we claim as new and desire to secure by Letters Patent; is,

1. In a screen structure, a plurality of members adapted to be secured to each other at their extremities to constitute a frame, 50 including side rails and upper and lower end rails, upturned flanges having inwardly extending portions, provided on the side rails and the lower end rail, an outwardly extending angularly disposed flange provided on the upper end rail, a parallel strip spaced therefrom, a packing strip arranged therebetween, means for securing the strips to the angular flange, and a screen fabric secured to the frame members, the outer 60 strip and the inwardly extending portions of the flanges constituting a housing for the edges of the screen fabric.

2. In a screen frame including side rails, and a lower end rail provided with inturned 65 outer marginal edges adapted to house the edges of a screen fabric, an upper end rail having an angularly disposed extended edge, a cover strip having angularly disposed portions adapted to be secured to the upper 70 end rail with the angular portions thereof arranged parallel to said upper end rail and the extension respectively, and a packing strip arranged between the extension and the mating portion of the cover strip, the 75 space between the remaining portion and the upper end rail constituting a housing for the edge of the screen fabric.

3. A screen frame as characterized in claim 2 in which the side and end rails and 80 the cover strip comprise relatively adjustable sections.

MORRIS J. ROTH.
ABRAHAM ROTH.