

Aug. 4, 1942.

F. C. KOLLATH

2,291,908

LAMP GUARD

Filed Feb. 13, 1941

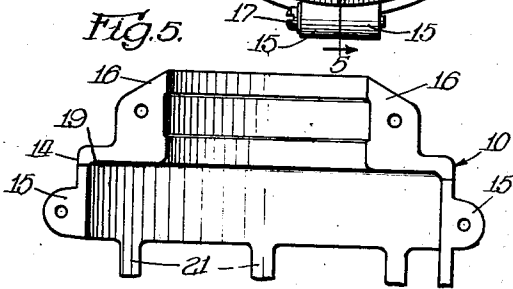
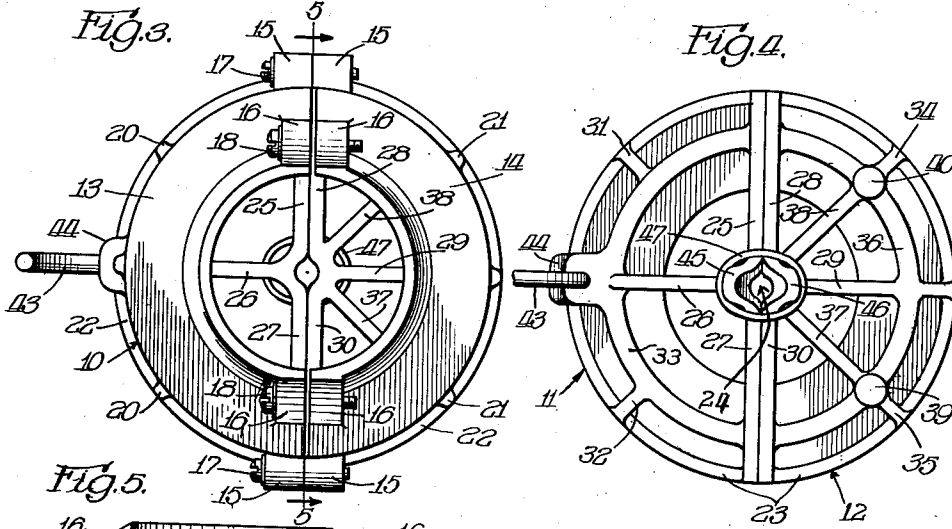
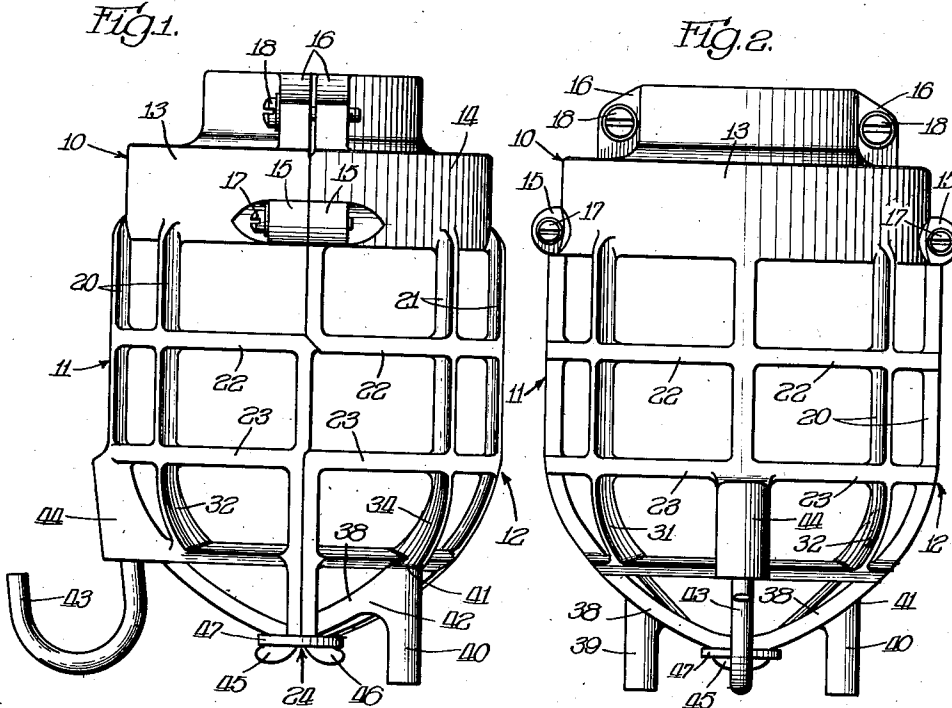

INVENTOR.
Francis C. Kollath
BY *Spencer, Margall, Johnston & Cook*
Attys.

UNITED STATES PATENT OFFICE

2,291,908

LAMP GUARD

Francis C. Kollath, Chicago, Ill.

Application February 13, 1941, Serial No. 378,735

1 Claim. (Cl. 240—102)

This invention relates to lamp guards. More particularly, it relates to lamp guards assembled from a plurality of sections for removably associating the lamp guard with a portable handle.

One object of this invention is to provide a tripod leg arrangement on the lamp guard so that the lamp may be stood firmly on a three-point contact. By this arrangement one using a light protected by such a lamp guard will be able to stand it firmly on a floor even though the floor is cluttered with various things such as tools.

Another object of this invention is to so extend the ends of the legs forming the tripod beyond the lamp guard that portions of the lamp guard will not interfere with the ability of the legs to act as a tripod when the lamp guard is rested upon uneven surfaces.

Another object of this invention is to position such an arrangement of legs on a sectional type of lamp guard. More specifically, lamp guards are frequently of the cast type. In order that these guards may be closely positioned around a lamp, the guard may be formed of two cast sections which are held in assembled relationship by any suitable means. One of the features of this invention is the provision of two supporting legs on one of the complementary sections forming a lamp guard and the provision of a hook means on the other section to provide the requisite tripod arrangement when the two sections are mounted in assembled relationship, while nevertheless maintaining a symmetry of line without sacrificing requisite strength.

Numerous other objects and advantages will be apparent throughout the progress of the following specification.

The accompanying drawing illustrates selected embodiments of the invention, and the views therein are as follows:

Figure 1 is an elevational view of one form of lamp guard embodying the invention;

Figure 2 is another elevational view at right angles to that shown in Figure 1;

Figure 3 is a plan view of the base of the lamp guard;

Figure 4 is a plan view of the curved end of the lamp guard; and

Figure 5 is a view of the interior of the base or collar portion of one of the sections making up the lamp guard.

Continuing to refer to the drawing, and particularly to Figures 1 and 2, the lamp guard is generally identified by the numeral 10 and com-

prises two complementary sections 11 and 12. Each of the complementary sections 11 and 12 have semi-circular ring portions 13 and 14 carrying outwardly extending shoulders or bosses such as 15 and 16. These shoulders 15 and 16 are suitably drilled and threaded to receive holding means such as screws 17 and 18.

When the two sections 11 and 12 are assembled together in the manner shown in Figure 1, the semi-circular ring portions 13 and 14 form a collar or gripping element having an interior channel 19, see Figure 5, which may be closed around an enlarged portion of a handle for holding the lamp guard to the handle. Extending from the semi-circular ring portions 13 and 14 of each of the complementary sections 11 and 12 is a protective webbing composed of a plurality of web elements such as 20 and 21, which elements are interconnected by lateral web elements such as 22 and 23. Referring to Figure 4, the web elements 25, 26 and 27, which are 90° apart on the complementary section 11, are extensions of elements 20 and are curved toward an apex 24 while the web elements 28, 29 and 30, also 90° apart, are extensions of elements 21 and are curved toward the apex 24. The web elements 31 and 32 terminate at the lateral web element 33. The web elements 34 and 35 normally would terminate at the lateral web element 36, but in order to provide the requisite structural strength for two supporting leg members 39 and 40, while retaining desirable symmetrical lines for the lamp guard as a whole, are continued by the web elements 37 and 38 to the apex 24.

Describing now the three supporting legs for the lamp guard, the legs 39 and 40 are cast integral with the complementary section 12 as continuations of the web elements 34 and 35 at the points where the lateral web member 36 joins the web elements 34 and 35. If the leg members 39 and 40 received no support excepting that of the lateral web element 36, the web elements 34 and 35 would of necessity have to be greatly enlarged at the cost of symmetry of the lamp guard because it is essential that the leg members 39 and 40 not break off from the lamp guard due to a sharp blow such as that caused by falling on a cement floor. In order to retain the web elements 34 and 35 at a size comparable to the web elements 31 and 32, see Figure 4, applicants have provided the additional web elements 37 and 38. By supporting the leg elements 39 and 40, therefore, not only at their ends but laterally, the web elements 34 and 35, of

the complementary section 12 will be retained at a size so that symmetry with the other complementary section 11 will be retained.

The third leg that forms the tripod comprises, referring to Figure 1, a hook member 43 mounted in an enlarged portion 44 on the web elements of the section 11 where these elements commence to curve toward the apex 24.

Attention is invited to the fact that the tripod established by the hook member 43 and the leg members 39 and 40 terminates in a plane, all points of which are at a substantial distance from the apex 24. This distance may be varied to suit requirements, the point being that a portion of the lamp guard itself should not extend so closely to the plane through the ends of the supporting legs that the portion of the lamp guard may under certain circumstances become a leg itself, and in so doing make it difficult to properly position the lamp guard. The arrangement shown is for the specific purpose of enabling the lamp guard to obtain a firm footing even though its legs straddle a wrench or some other tool lying on a floor or to assist in standing the lamp on its legs on some uneven surface such as ground.

In order to assemble the two sections 11 and 12, the latter are provided at the tip of their rounded portion with ears 45 and 46 which are inserted through a ring 47 when the two sections are spread apart. The ring 47 plus the screws such as 17 and 18 hold the two sections in assembled relationship.

The invention consists in providing a tripod on the end of a multiple section lamp guard in such a way that the legs may properly function to firmly support the lamp guard when positioned on an uneven surface, while said legs nevertheless are not permitted to distort the symmetry of the sections forming the lamp guard.

Changes may be made in the form, construction and arrangement of the parts without departing from the spirit of the invention or sacrificing any of its advantages, and the right is hereby reserved to make all such changes as may fairly fall within the scope of the following claim.

The invention is hereby claimed as follows:

A two-part lamp guard comprising a pair of complementary guard members each cast from metal and having longitudinally and transversely extending webs curved generally to the shape of a lamp globe and providing light openings between the webs, one of said guard members having a pair of spaced depending lugs formed integrally therewith at the junctions of two of said longitudinally extending webs with one of said transverse webs, said longitudinal webs extending downwardly from said junctions to an apex to reinforce and strengthen said lugs, the other of said guard members having a lug cast integrally therewith at the junction of one of said longitudinally extending webs and at least one of said transverse webs, said longitudinal web extending downwardly from said junction to said apex to reinforce and strengthen said third lug, a hook shaped member depending downwardly from said last mentioned lug, an outwardly turned ear on each of said guard members at said apex, a locking ring within which said ears are received when said guard members are separated, means at the other ends of said guard members for drawing the members together, and said first mentioned pair of lugs and said hook member extending downwardly to substantially a common plane spaced below said ears to provide a tripod support for the lamp guard.

FRANCIS C. KOLLATH.