

(No Model.)

4 Sheets—Sheet 1.

F. G. & A. C. SARGENT.
FIBER DRYING MACHINE.

No. 527,721.

Patented Oct. 16, 1894.

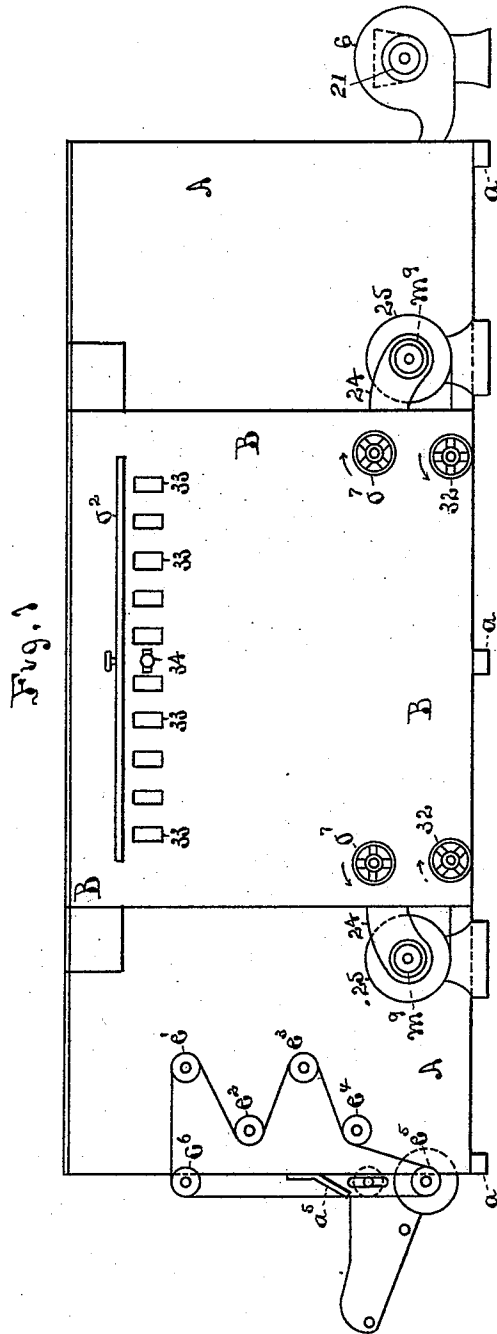

Fig. 1

Witnesses
Wm. D. Brown
A. P. Ockington.

Inventors:
Frederick G. Sargent
Allan C. Sargent
By David Hall Rice
Atty

(No Model.)

4 Sheets—Sheet 2.

F. G. & A. C. SARGENT. FIBER DRYING MACHINE.

No. 527,721.

Patented Oct. 16, 1894.

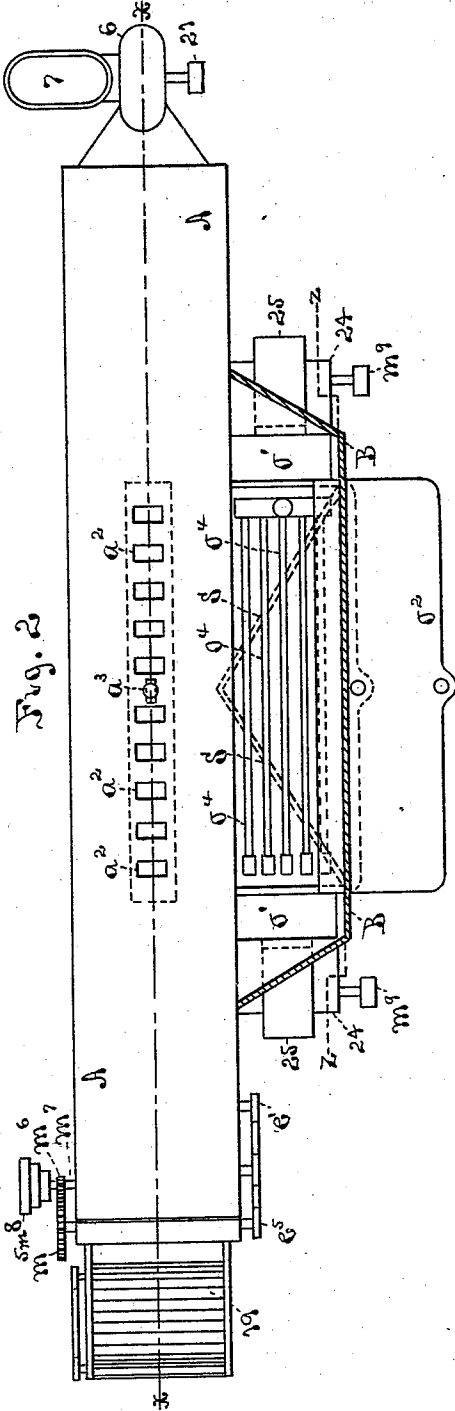

Fig. 2

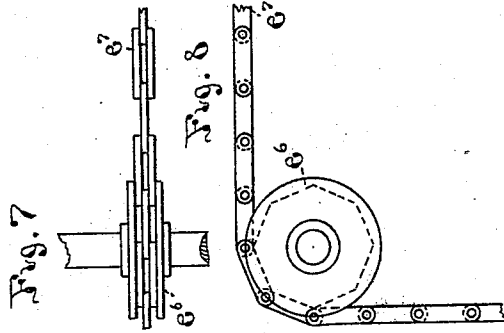

Fig. 7

Fig. 8

Fig. 5

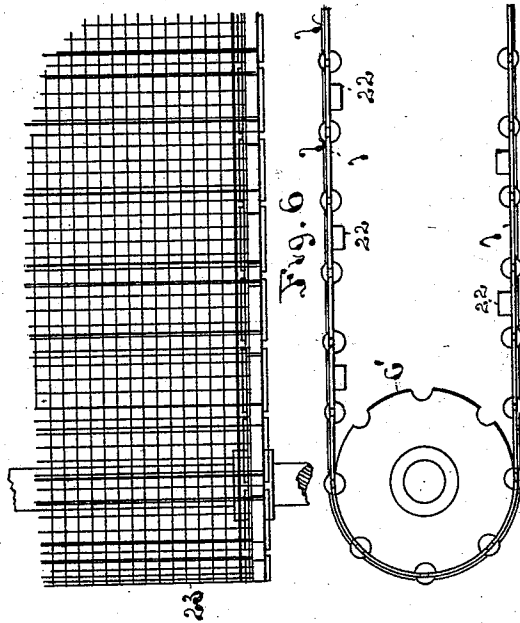

Fig. 6

Witnesses
Wm. D. Brown
A. P. Dickinson

Inventors,
Frederick G. Sargent
Allan C. Sargent
 By *David Wallace*
 Atty.

F. G. & A. C. SARGENT.
FIBER DRYING MACHINE.

No. 527,721.

Patented Oct. 16, 1894.

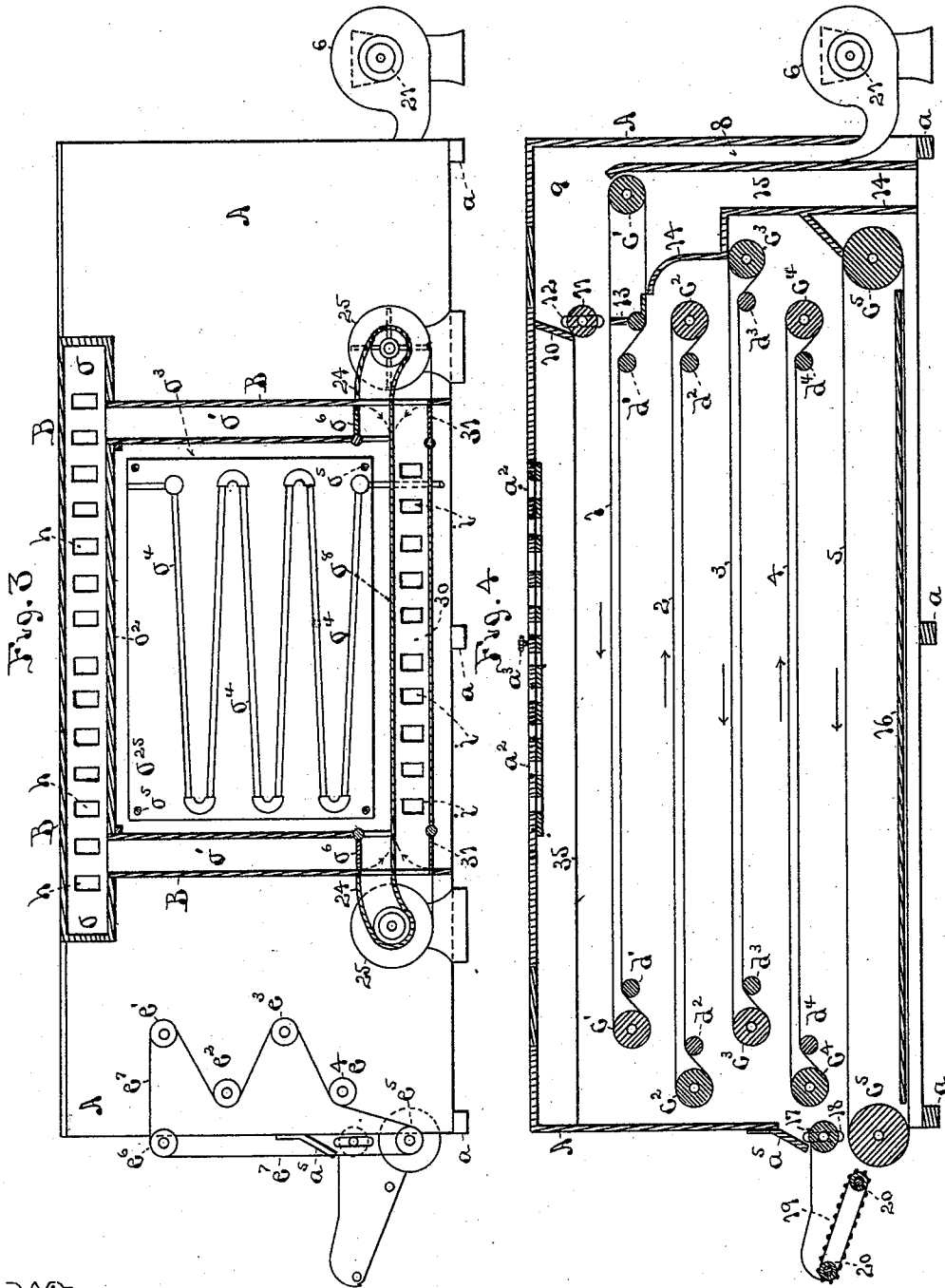

Witnesses

Wm. D. Brown
A. P. Ockington

Inventors:

Fredrick G. Sargent
Allan C. Sargent
By David Hall Lee
Atty

(No Model.)

4 Sheets—Sheet 4.

F. G. & A. C. SARGENT.
FIBER DRYING MACHINE.

No. 527,721.

Patented Oct. 16, 1894.

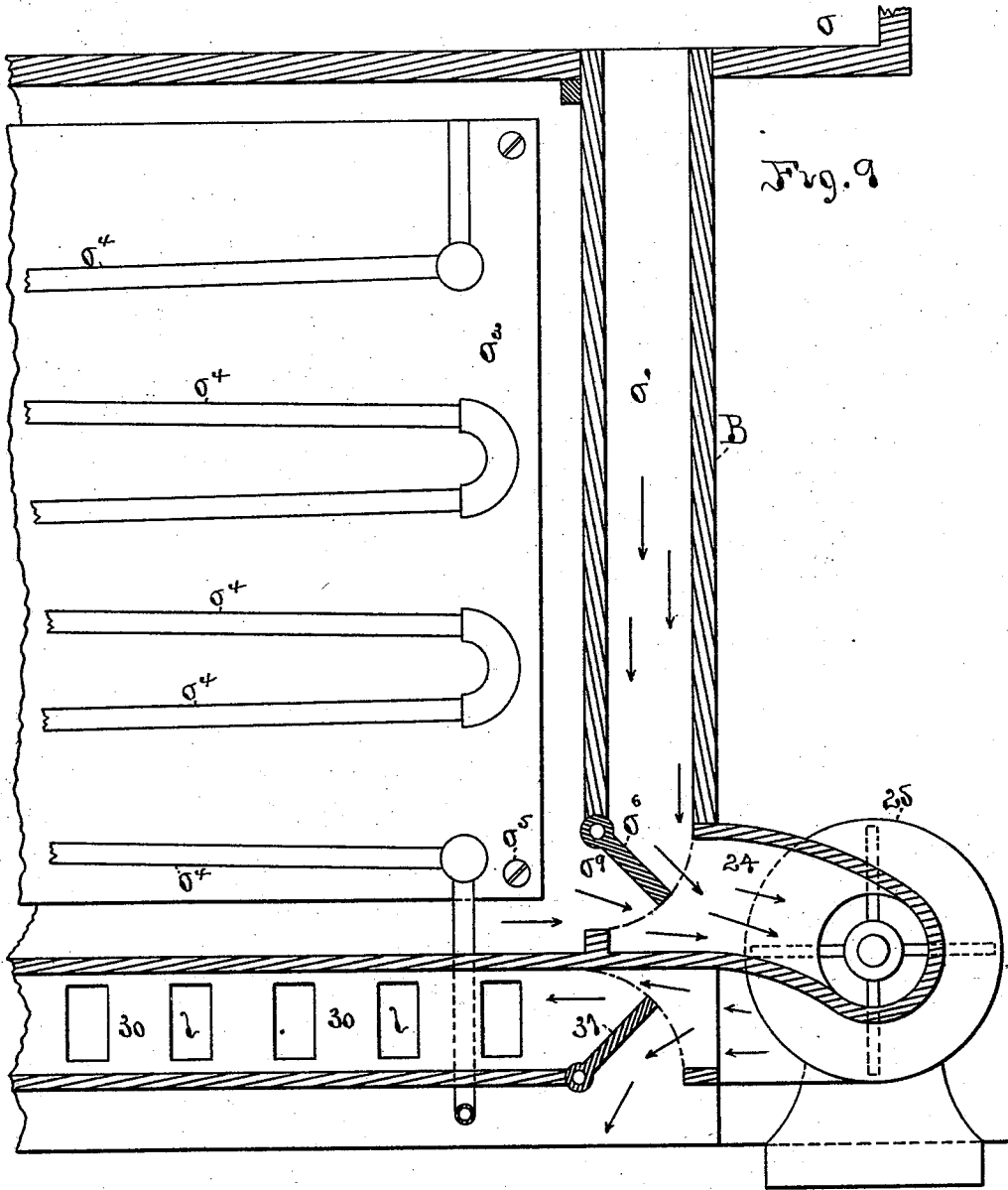

Witnesses

W. D. Brown
A. P. Ockington

Inventors:

Frederick G. Sargent
Allan C. Sargent
By *Lepine & Rice*
Attorney.

UNITED STATES PATENT OFFICE.

FREDERICK G. SARGENT AND ALLAN C. SARGENT, OF GRANITEVILLE,
MASSACHUSETTS.

FIBER-DRYING MACHINE.

SPECIFICATION forming part of Letters Patent No. 527,721, dated October 16, 1894.

Application filed February 5, 1892. Serial No. 420,393. (No model.)

To all whom it may concern:

Be it known that we, FREDERICK G. SARGENT and ALLAN C. SARGENT, of Graniteville, in the county of Middlesex and State of Massachusetts, have invented a new and useful Improvement in Fiber-Drying Machines, of which the following is a specification.

Our invention relates to machines for drying fiber and especially for drying various kinds of wool, and it consists in certain improved constructions and combinations of the various parts of the same, substantially as hereinafter described and claimed.

In the drawings:—Figure 1 is a side elevation of a drying machine. Fig. 2 is a top plan view of the same, with the cover of the steam chest and connected passages removed. Fig. 3 is a side elevation with the steam chest and fans in vertical section on the dotted line $z-z$ of Fig. 2. Fig. 4 is a vertical section through the main drying apparatus, on the line $x-x$ of Fig. 2. Figs. 5 and 6 are respectively a plan and side view of a portion of one of the drying screens of the drier, showing the details of their construction. Figs. 7 and 8 are respectively plan and side views of the chain belt and one of its pulleys, which drives the movable screens during the drying process. Fig. 9 is an enlarged drawing of the blower connections shown in Fig. 3.

A is the casing of the main part of the drier, which contains the traveling drying screens.

B is the casing of the steam box and air passages, for drying, heating and circulating the air; the latter being attached to one side of the casing of the drier.

The drier is supported on feet, a, a , which allow the air to pass underneath it. The casing A is also provided with a series of openings a^1, a^2 , in its top which is closed by a sliding damper operated by a knob, a^3 , projecting through the casing.

Internally the drier is provided with a series of traveling screens, 1, 2, 3, 4, 5, having their upper surfaces traveling in the direction indicated by the arrows and passing around the rollers c^1, c^2, c^3, c^4, c^5 . These rollers are so disposed that when the fiber has arrived at the end of one apron it falls down onto the upper surface of the next lower one, which projects far enough beyond to receive it and

carry it in the opposite direction. In order to allow the fiber to have more room between each apron and the one next above it, we provide a series of idler rollers d^1, d^2, d^3, d^4 , journaled in the casing on each side to elevate the lower portion of each apron above a straight line extending from the lower periphery of one roller to the other, as shown in Fig. 4. This allows the air flowing upward through the screens to lift and loosen the fiber, causing it to dry quicker.

The fiber is fed into the drier by the blower, 6, which has a hopper, 7, into which the fiber is thrown, it being delivered to the drier through the blower and the spout, 8, which elevate it on top of the screen, 1, into the chamber 9. This chamber is separated from the other parts of the drier by the partition, 10, and roller, 11, which has a capacity of movement up and down in a slot, 12, made at each end of the roller, in the casing, for its axis to rise and fall in to accommodate the fiber passing under it on the screen 1, and entering the main portion of the drier casing. A partition, 13, is provided between the upper and lower traveling portions of the screen, 1, opposite the roller, 11, which serves to cut off the portion between the two parts of the screen 1 below the chamber, 9, and another partition, 14, underneath screen 1 forms the passageway, 15, leading through the bottom of the drier from the chamber 9. This conveys away the air forced into chamber 9 by the blower to convey the wool onto screen, 1, by allowing it to pass downward through the screen and the passage, 15, and out of the drier. This arrangement for the escape of the air current created by the blower, 6, serves to distribute the fiber more evenly over the apron, 1, preparatory to its passing under the roller, 11, into the drying chamber proper, and also prevents the cooler air of this current from mingling with the hot air of the drying chamber and suddenly cooling the latter, causing it to leave moisture on the wool instead of drying it.

To inclose the main chamber of the drier, the partition 16 is attached to the side walls and has its ends extending as closely as possible to the rollers c^5, c^5 . At the feed-out end of the drying chamber the roller, 17, as an idler

roller, bears down upon the fiber passing out, its bearings working up and down in the slot, 18, in the same manner as the roller, 11, operates as before described. The supplemental casing, a^5 , inclines outward to accommodate the roller, 17, and allow it to rise and fall as described.

From the apron, 5, delivering the fiber out of the drier, the supplemental apron, 19, passing over the rollers, 20, 20, receives and conveys it away. The several aprons are driven by the pulleys e^1, e^2, e^3, e^4, e^5 , attached to the ends of their roller shafts, which pass through the casing to its exterior. Around these rollers and the idler pulley, e^6 , the chain belt, e^7 , is passed. The delivering-out roller, c^5 , has attached to its other end the gear wheel, m^5 , which is driven by the pinion, m^6 , attached to a counter shaft, m^7 , which is provided with a cone pulley on its outer end, m^8 . The blower 6 is driven by a belt leading from a suitable counter shaft upon the pulley, 21.

The traveling screens 1, 2, 3, 4, 5, are formed as shown in detail in Figs. 5 and 6. They have a chain belt or series of links, l , pivoted together at each end, carrying not only the cross bars, 22, but supporting each edge of the wire screen apron, 23. This arrangement prevents undue stretching of the wire screen apron, and by means of the cross bars, 22, prevents its sagging down in the middle under the continued weight of the wet and heavy wool passing over during the drying process. We are enabled by this means to stretch the aprons taut with the requisite tension at their edges on the chain to prevent undue sagging, without at the same time, by this stretching, expanding and pulling the wire meshes on the edges of the apron so that they become longer than the middle part and longer on one edge than the other, which prevents the apron from traveling evenly around its rollers. Again, we prevent the strain of the load carried on the center of the wire screen apron unduly stretching the meshes at that point and impairing or destroying its efficiency in a short time. We thus overcome these well-known difficulties, which are due to the stiffness of the wire and difficulty of causing it to fit snugly and evenly together, when the wire screen material is woven to form the apron. The edges of the wire apron are attached to the links of the chain, which form its edges, by means of soldering or by being bent around through one side of the links and twisted back into the apron. The object aimed at by this arrangement of slats attached to the side chains beneath the apron and with the woven wire attached to the side chains or carriers, is to locate the contact surfaces of the slats and wire apron in the pivot line or neutral axis of the carriers, so that when the carriers and apron pass around the supporting rollers at either end there will be no tendency either to stretch or to buckle the

woven wire of which the apron is composed, and at the same time to furnish proper support for the portion of the apron between the two rollers when weighted with the material that is drying.

In the upper part of the casing A, in one side, we provide the openings, h, h, h , for the escape of air from the drier, and in the lower part of the same side underneath the upper surface of screen 5, we provide openings, i, i , for the admission of the air. Around and connecting these openings is arranged the casing, B. The openings, h , lead into a chamber, o , which has in its lower part the passages o', o' , leading downward, and is separated by the slide, o^2 , from a larger chamber, o^3 , underneath it, which contains steam pipes, o^4 , connected to any suitable source of steam supply, to heat the air brought in contact with them. In the lower part of chamber, o^3 , at each end are openings o^9 which lead into the lower ends of the passages, o' , and a pair of valves, o^6 , is arranged as shown so that when raised, as shown in Fig. 3, they close the upper part of the passages o' and open the openings o^9 into the lower part of the passages o' , which connect with conduits, 24, which lead direct to the blowers, 25, 25. When, however, the valves, o^6 , are swung downward as indicated by dotted lines, they will close the openings o^9 , and connect the passages, o' , directly with the blower passages 24. The valves o^6 are operated by the hand wheel, o^7 , on the ends of their pivot shafts, which project through the casing.

The chamber, o^3 , is shut off from the passages i, i , into the drier by means of a bottom partition, o^8 , which extends through from one side casing B to the other and forms the top of a passage, 30, into which the blowers 25, 25, discharge the air at each end from the periphery of their respective casings. At each end of the bottom wall of passage, 30, is a valve, 31, mounted on a revolving shaft as shown, the outer end of which projects through the casing and is provided with a hand wheel, 32, to operate the valve. The openings i, i , lead from the passage 30 into the drier. When the valves 31, 31, are set as shown in Fig. 3, the air is consequently blown into the drier through the passage 30 and openings, i , but when the valves are swung upward, as indicated by the dotted lines, the air is blown from each blower directly out of the machine underneath it.

A series of openings 33, 33, is made in the casing B directly below the slide, o^2 , (Fig. 1) which are opened and closed by a sliding damper operated by the knob, 34. Sometimes we provide the air passage, 30, with deflecting boards or partitions, as indicated by the dotted lines. The blowers 25, 25, are driven by pulleys m^9, m^9 , on the ends of their shafts.

A horizontal screen, 35, is placed above the

upper traveling apron, *l*, in the drier to prevent the fiber being carried upward through the openings, *h*, or the openings, *a*².

It will be seen that this drier is susceptible of use either as an exhaust drier, or as a drier for circulating heated or ordinary air through the fiber on the traveling screens. For example, when the damper of the openings *a*², is closed and the damper of the openings *33*, *33*, is closed and the slide, *o*², is drawn out as shown in Fig. 2, and the valves *o*⁶, *o*⁶, and *31*, *31*, are in the position shown in Fig. 3, the operation of the blowers, 25, will create a constant circuit of air out of the drier through the openings, *h*, down through the steam pipes, *o*⁴, thence through the blowers and back again into the drier by way of passages, 30, and openings *i*, *i*. If now it be desired to admit air from the outside to any extent, it may be done by opening the damper of the openings, 33, 33, and opening the damper of the openings *a*², *a*². This will admit a certain portion of outer air to be heated by the steam pipes and blown upward through the drying screens, and escape through the openings *a*², *a*², the slide *o*² being of course pushed in sufficiently to regulate the proportion of air admitted and expelled to that making the entire circuit.

If it be desired to use the machine as an exhaust drier and thus extract the moisture from the fiber, the dampers of openings *a*², *a*², and 33, will be closed, the slide *o*² will be closed, and the dampers *o*⁶, will be swung downward opening the passages *o*⁷ to the blowers, and the valves 31, 31, will be swung upward, when the blowers will operate to exhaust the air from the drier and deliver it outside of the machine. Variations of these manipulations may be carried on as, for example, with the dampers *o*⁶ and valves, 31, in the position last supposed, the dampers of openings *a*², *a*², may be slightly opened, or the dampers *o*⁶ and valves, 31, may be so adjusted as to pass the air through the fans partly without heating and partly by heating, or to throw part of the air out of the machine, or send part of it round in the machine through the openings *i* as shown in Fig. 9. These various arrangements will readily suggest themselves to the practical operator on examination.

The steam heating chamber, *o*⁸, is separated from the main drying chamber of the drier by means of a metal plate, *o*²⁵, which is secured over an opening cut in the casing A by means of screws *o*⁵ at the corners as shown. This plate, *o*²⁵, allows the heat from the steam chamber to radiate more readily through it into the drying chamber, while the casing A of the drying chamber being formed of wood and the outer casing of the steam chamber being also formed of wood or other similar

non-conducting material, prevents radiation outward into the open air as readily as if it were formed of metal.

What we claim as new and of our invention is—

1. The combination in a fiber drying machine of a feeding-in-blower, a receiving chamber for the fiber fed by said blower, which is provided with an air exit passage, a main drying chamber adjacent to the receiving chamber, and a traveling screen which extends from the receiving chamber into the drying chamber and is adapted to separate the fiber from the current of air by which it is fed to the receiving chamber and convey it into the drying chamber substantially as described.

2. The combination in a fiber drying machine of a main drying chamber, traveling screens mounted therein and arranged to deliver the fiber successively from one to another and thereby convey it through the chamber, air passages in the walls of said chamber both above and below said screens to serve as outlets and inlets for air, and an air conduit connecting the said upper and lower air passages; heating apparatus within a chamber also connected with said upper and lower air passages, and forming a second air conduit between them, a blower connected with both of said air conduits, and valves in each to regulate the currents of air produced by the action of the blower substantially as described.

3. The combination in a fiber drying machine of a main drying chamber having air ports in the top thereof, traveling screens therein arranged to deliver the fiber successively from one to the other and thereby convey it through said chamber, openings in a wall of said chamber above and below said screens to serve as outlet and inlet passages for air, heating apparatus within a chamber connected with said inlet and outlet passages and serving as one air conduit between them; a second air conduit connecting said outlet and inlet passages independently of the heating chamber, a blower connected with both of said air conduits, and valves therein to regulate the air currents from the blower as desired, substantially as described.

4. In a fiber drying machine, the combination of a drying chamber, and a traveling apron therein which consists of side carriers, cross-slats attached thereto, and a wire apron outside of said slats, with the contact surface of the slats and apron in the pivot line or neutral axis of the carriers.

FREDERICK G. SARGENT.

ALLAN C. SARGENT.

Witnesses:

F. P. HAWKES,

W. A. HARRIS.