

19



ORGANISATION AFRICAINE DE LA PROPRIETE INTELLECTUELLE

51

Inter. Cl.⁸

C10M 107/32

11

N° 16410

FASCICULE DE BREVET D'INVENTION

21

Numéro de dépôt : 1201300199
(PCT/EP11/005524)

22

Date de dépôt : 02/11/2011

30

Priorité(s) :
FR n° 10/04399 du 10/11/2010

24

Délivré le : 30/04/2014

45

Publié le : 07.10.2015

73

Titulaire(s) :

VALLOUREC MANNESMANN OIL & GAS FRANCE,
54, rue Anatole France,
59620 AULNOYE-AYMERIES (FR)

NIPPON STEEL & SUMITOMO METAL CORPORATION,
6-1, Marunouchi 2-chome,
Chiyoda-ku, TOKYO 100-8071 (JP)

72

Inventeur(s) :

GARD Eric (FR)
PINEL Eliette (FR)
PETIT Mikael (FR)
GOUIDER Mohamed (FR)

74

Mandataire : Cabinet CAZENAVE SARL,
B.P. 500, YAOUNDE (CM).

54

Titre : Process for coating a threaded tubular component, threaded tubular component and resulting connection.

57

Abrégé :

The invention concerns a threaded tubular component for drilling or working hydrocarbon wells, said tubular component having at one of its ends (1; 2) a threaded zone (3; 4) produced on its outer or inner peripheral surface depending on whether the threaded end is male or female in type, in which at least a portion of the end (1; 2) is coated with at least one lubricating dry film (12) comprising at least 65% by weight of a polyaryletherketone. The invention also concerns a process for depositing said film (12).

**PROCESS FOR COATING A THREADED TUBULAR COMPONENT, THREADED
TUBULAR COMPONENT AND RESULTING CONNECTION**

The present invention relates to a tubular component used for drilling and working
5 hydrocarbon wells, and more precisely to the threaded end of such a component, said end being
male or female in type and capable of being connected to a corresponding end of another
component to form a connection.

The invention also relates to a process for producing a galling-resistant film on such a
tubular component.

10 A component which is "used for drilling and working hydrocarbon wells" means any
element which is substantially tubular in form intended to be connected to another element of the
same type or otherwise to finally constitute either a string for drilling a hydrocarbon well or a
riser intended for maintenance (also known as work-over risers) or for working, such as risers, or
for a casing string or tubing string used in working wells. The invention is also applicable to
15 components used in a drill string, such as drill pipes, heavy weight drill pipes, drill collars and
the portions of pipe connections and heavy weight pipes known as tool joints.

Each tubular component comprises one end provided with a male threaded zone and/or
one end provided with a female threaded zone each intended to be connected by screwing with
the corresponding end of another component, the assembly defining a connection.

20 Threaded tubular components are connected under defined stresses in order to satisfy the
requirements for tightening and sealing imposed by the service conditions, knowing that at the
well, the threaded tubular components may be required to undergo several makeup-breakout
cycles.

The conditions for use of such threaded tubular components give rise to different types of
25 stresses which make it necessary to use coatings on the sensitive portions of such components
such as the threaded zones, abutments or sealing surfaces.

Screwing operations are generally carried out under a high axial load, for example the weight of a tube several metres in length to be connected via the threaded connection, possibly localized by a slight misalignment of the axis of the threaded elements to be connected, which induces risks of galling at the threaded zones and at the metal/metal sealing surfaces. For this reason, it is necessary to coat the threaded zones, the abutment surfaces and the metal/metal sealing surfaces with lubricants.

Furthermore, the threaded tubular components are stored (sometimes for several years), then made up in a hostile environment. This is the case, for example, in an offshore situation with a salt spray and in an onshore situation when sand, dust or other pollutants are present. Thus, it is necessary to use coatings that counter corrosion, on the surfaces which have to cooperate by screwing (threaded zones) or by interfering contact (metal/metal sealing surfaces). It is also necessary to treat the surfaces against corrosion.

Environmentally, however, it appears that using screwing greases conforming to API (American Petroleum Institute) standard RP 5A3 does not constitute a long-term solution because such greases, which contain heavy metals, can be expelled from the tubular components and released into the environment or into the well, resulting in plugging which necessitates special cleaning operations. Furthermore, such greases do not provide sufficient protection against corrosion and have to be applied on site for each screwing operation.

In order to overcome the problems of requiring a long-term corrosion resistance and resistance to galling and to satisfy environmental prerogatives, the principal protagonists in the field of threaded connections have been actively developing solid dry coatings (i.e. not pasty and not tacky like greases) which are both lubricants and protect against corrosion, and which can be applied definitively, at the factory, to the tubular components.

In particular, coatings which are inert as regards the environment and which are resistant to wear are being developed.

VL

The present invention is based on the discovery that using polyaryletherketones enables to obtain lubricating dry films which are highly resistant to wear, anti-galling, have high mechanical strength, with a low coefficient of friction and which are resistant to extreme hydrocarbon well working conditions. The solutions employed can also be adapted to various
5 grades of metal for the connections for the tubular components cited above.

The use of such polyaryletherketones and their properties in the context of threaded tubular components as defined above have neither been described nor suggested in the prior art.

More precisely, the invention concerns a threaded tubular component for drilling or working hydrocarbon wells, said tubular component having at one of its ends a threaded zone
10 produced on its outer or inner peripheral surface depending on whether the threaded end is male or female in type, in which at least a portion of the end is coated with at least one lubricating dry film comprising at least 65% by weight of a polyaryletherketone.

Optional characteristics, which are complementary or substitutional, are defined below.

The polyaryletherketone is selected from a polyetheretherketone (PEEK), a polyetherketone
15 (PEK) and mixtures thereof.

The lubricating dry film has a structure with a degree of crystallinity in the range 10% to 35%.

The lubricating dry film further comprises at least one class 4 solid lubricant in a proportion by weight in the range 10% to 35%.

20 The lubricating dry film comprises a perfluoroalkoxyethylene copolymer in a proportion by weight in the range 10% to 30%.

The lubricating dry film comprises a mechanical reinforcing agent selected from the list of the following pigments: carbon black, mica, wollastonite, nanometric aluminium oxide, nanometric titanium oxide, glass powders, nano-diamond, nanometric WS₂ or WS₂-fullerenes, in a proportion
25 by weight in the range 1% to 15%.

EL

The portion coated with lubricating dry film has previously undergone a surface preparation step selected from the group constituted by sanding, manganese phosphatation, electrolytic deposition of Cu or Cu-Sn-Zn alloys, and Fe and Zn alloys deposited by projection.

The portion coated with lubricating dry film has previously been coated with an undercoat
5 of polyetheretherketone with a semi-crystalline structure and containing mica pigments.

The entire threaded zone is coated with lubricating dry film.

The threaded tubular component comprises a metal/metal sealing surface, said sealing surface being coated with lubricating dry film.

The invention also concerns a threaded tubular connection comprising a male threaded
10 tubular component and a female threaded tubular component made up one into the other, in which at least one of said threaded tubular components is as defined above.

The invention also concerns a process for coating a threaded tubular component for drilling or working hydrocarbon wells, said tubular component having at one of its ends a threaded zone produced on its outer or inner peripheral surface depending on whether the threaded end is male or
15 female in type, comprising the following steps:

- producing a mixture comprising a polyaryletherketone powder in suspension in water, in proportions in the range 25% to 35% by weight;
- applying said mixture to a portion of the end of said threaded tubular component;
- drying the portion of the end thus coated at a temperature in the range 100°C to
20 150°C for a period in the range 5 to 10 minutes;
- heating the thus coated portion of the end to a temperature in the range 350°C to 450°C for 5 to 15 minutes at a rate of increase in temperature in the range 10°C to 20°C per minute;
- cooling the thus coated portion of the end to ambient temperature at a cooling rate of
25 less than 10°C per minute, in order to obtain a principally crystalline structure.

Optional characteristics, which are complementary or substitutional, are defined below.

B.L

The mixture also comprises a coalescing agent with a rapid evaporation rate with a boiling point in the range 100°C to 200°C and in proportions in the range 2.5% to 10% by weight.

The mixture further comprises a non-ionic wetting and dispersing agent in proportions in the range 2.5% to 10% by weight.

The mixture also comprises at least one class 4 solid lubricant in proportions in the range 3% to 12% by weight.

The class 4 solid lubricant is a perfluoroalkoxyethylene copolymer in a proportion by weight in the range 3% to 12%.

The mixture also comprises a mechanical reinforcing agent selected from the list of the following pigments: carbon black, mica, wollastonite, nanometric aluminium oxide, nanometric titanium oxide, glass powders, nano-diamond, nanometric WS₂ or WS₂-fullerenes, in a proportion by weight in the range 0.5% to 5%.

The portion of the end is coated using a pneumatic spray system, the diameter of said system being in the range 0.7 to 1.8 mm and the air pressure being in the range 4 to 6 bars.

A surface preparation step selected from the group constituted by sanding, manganese phosphatation, electrolytic deposition of Cu or Cu-Sn-Zn alloys, and particles of Fe and Zn alloys deposited by projection is carried out before applying the mixture to the portion of the end.

A surface preparation step consisting of producing an undercoat of polyetheretherketone with a semi-crystalline structure and containing mica pigments is carried out before applying the mixture to the portion of the end.

The invention also concerns a process for coating a threaded tubular component for drilling or working hydrocarbon wells, said tubular component having at one of its ends a threaded zone produced on its outer or inner peripheral surface depending on whether the threaded end is male or female in type, which comprises the following steps:

PL

- heating a portion of the end of said threaded tubular component to a temperature in the range 360°C to 420°C, preferably to a temperature close to 400°C;
- projecting PEK and/or PEEK powders onto the portion of the end of said threaded tubular component;
- 5 • maintaining the thus coated portion of the end at a temperature in the range 360°C to 420°C, preferably at a temperature close to 400°C, for a period in the range 1 to 4 minutes;
- cooling the thus coated portion of the end to ambient temperature at a cooling rate of less than 10°C per minute, in order to obtain a principally crystalline structure.

10 Advantageously, a step for degreasing the portion to be coated is carried out before heating said portion.

The features and advantages of the invention will be described in more detail in the description which follows, made with reference to the accompanying drawings.

15 Figure 1 is a diagrammatic view of a connection resulting from connecting two tubular components by makeup;

Figure 2 is a diagrammatic view of a screwing curve for two threaded tubular components;

Figure 3 is a diagrammatic view of a substrate coated with a lubricating dry film;

Figure 4 is a diagrammatic view of a test set-up;

20 Figure 5 is a diagrammatic view of another test set-up;

Figures 6 and 7 show test curves.

The threaded connection shown in Figure 1 comprises a first tubular component with an axis of revolution 10 provided with a male end 1 and a second tubular component with an axis of revolution 10 provided with a female end 2. The two ends 1 and 2 each finish in a terminal surface which is orientated radially with respect to the axis 10 of the threaded connection and are
25 respectively provided with threaded zones 3 and 4 which cooperate mutually for mutual

connection of the two components by screwing. The threaded zones 3 and 4 may be of the trapezoidal, self-locking, etc thread type. Furthermore, metal/metal sealing surfaces 5, 6 intended to come into scaled interfering contact against each other after connecting the two threaded components by screwing are provided respectively on the male and female ends close
5 to the threaded zones 3, 4. Finally, the male end 1 ends in a terminal surface 7 which comes into abutment against a corresponding surface 8 provided on the female end 2 when the two ends are made up one into the other.

The Applicant has also foreseen other configurations wherein the abutment formed in the present case by the two contact surfaces 7 and 8 is replaced by self-locking tightening
10 cooperation of the threaded zones 3, 4 (see US 4 822 081, US RE 30 467 and US RE 34467).

As can be seen in Figures 1 and 3, at least one of the threaded tubular connections is coated over a portion of its end 1, termed the substrate 11, with a lubricating dry film 12 comprising at least 65% by weight of a polyaryletherketone, said dry film 12 having a structure with a degree of crystallinity of at least 10%. It will be recalled here that the degree of
15 crystallinity is measurable by the enthalpy of fusion or crystallization (ΔH^0) of the polymer. The theoretical enthalpy of fusion for a totally crystalline polyaryletherketone, in particular a polyetheretherketone (PEEK) is 122 J/g according to Hay and Coll (Polymer Communications, 1984, 25, 175-178). The presence of a degree of crystallinity of at least 10% has the advantage of offering excellent mechanical properties, in particular a good torque on shoulder resistance.
20 However, it is preferable to keep the degree of crystallinity below 35% to preserve the characteristics of the film, in terms of adhesion and protection, of the surface preparation against corrosion.

The polyaryletherketones used in the invention may be obtained from aqueous polyetheretherketone dispersions or from aqueous polyetherketone dispersions. These aqueous
25 dispersions may comprise organic or inorganic mechanical reinforcing agents such as mica pigments of the muscovite and/or biotite type constituted by aluminium silicate and hydrated

potassium or magnesium, amorphous aluminium oxides with a gamma crystalline structure and with a particle size in the range 20 to 300 nm, titanium dioxide pigments with a particle size in the range 10 to 100 nm, perfluoroalkoxyethylene copolymer resins (PFA), amorphous carbon black pigments, synthetic graphite powders with a diameter of less than 5 μm , nano-diamond
 5 powders obtained by detonation and with a particle size in the range 4 to 6 nm, C type glass with a fibre thickness in the range 1 to 1.3 μm with a diameter $D_{90} < 50 \mu\text{m}$, WS2 fullerene nano materials with a particle size in the range 80 to 220 nm, or WS2 tungsten bisulphide lamellar pigments with a particle size $D_{50} = 55 \text{ nm}$.

Polyetheretherketones, the abbreviation for which is PEEK, and polyetherketones the
 10 abbreviation for which is PEK, are obtained by a nucleophilic substitution type synthesis pathway. Polyetherification results in rigid semi-crystalline polymers with high melting points. They fall into the category of the most high performance materials in the thermoplastic material range. They have a glass transition temperature of 143°C and, because of their semi-crystalline nature, retain their excellent mechanical properties up to temperatures close to their melting point
 15 which is 343°C . Their quasi-linear and aromatic structure provides PEEK and PEK with excellent long-term thermal stability.

The molecular structure of polyetheretherketones is as follows:

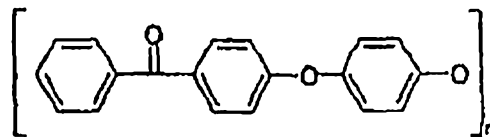

The molecular structure of polyetherketones is as follows:

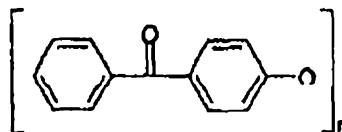

20

With a glass transition temperature of 157°C and a melting point of 374°C , polyetherketones, PEKs, offer extended performance at high temperatures compared with

polyetheretherketones, PEEKs, while having all the same advantages such as rigidity, solidity and chemical resistance.

The continuous service temperature is 240°C and the deformation under load temperature exceeds 300°C for reinforced grades of PEEK and PEK compared with other polymers.

5

PEEK has high level mechanical properties and retains its properties up to 250°C for tensile strength and up to 300°C for bending strength. These mechanical characteristics are greatly improved by incorporating 10% to 30% of solid lubricants such as graphite, carbon black, fluorinated PTFE type polymers or perfluoroalkoxyethylene (PFA) type resins, or glass

10

fibres.

PEKs supply up to three times the wear resistance of PEEKs at high temperatures and retain their mechanical and physical properties at temperatures of more than 30°C above those for PEEK while accommodating higher loads without permanent deformation.

15

PEEKs and PEKs have chemical resistance, in particular against saturated salt solutions, gaseous hydrogen sulphide at 200°C and also resistance to hydrolysis at 200°C under 1.6 MPa with a temperature resistance comparable to fluorinated polymers. Table 1 clearly shows the superior mechanical properties of PEEK and PEK compared with fluorinated polymers (PTFE and PFA).

Properties	PEEK	PEK	PTFE	PFA
Melting point (°C)	343	372	327	310
Continuous service temperature (°C)	260	280	260	260
Tensile strength (MPa)	100	100	14-35	28-31
Tensile modulus (GPa)	3.5	3.5	0.55	0.78
Bending modulus (GPa)	4	4	0.45	0.67
Hardness (Shore D)	D85	D85	D50-D55	D60-D64
Compressive strength (MPa)	118	118	-	12
Density	1.3	1.3	2.1-2.2	2.1-2.2

Table 1

20

Various implementations are possible for PEKs and PEEKs, but involve a transformation by melting at a temperature in the range 370°C to 420°C. Deposition may be carried out by

electrostatic powder projection, by spraying aqueous dispersions and by thermal projection. In the molten state, PEEKs and PEKs are not sensitive to corrosion, but they may be polluted by the moulds formed from alloys containing copper or chromium (as in certain grades of martensitic stainless steels comprising 13% of chromium, for example) which will catalyse degradation and produce coatings less resistant to oxidation. Overall, after transformation by melting, PEKs and PEEKs adhere well to metal, especially if it is not well polished. The permitted roughness represents between 20% and 25% of the total desired thickness of the dry film. The adhesion may be increased using an undercoat as an adhesion promoter or by using a surface treatment by mechanical abrasion (sanding or shot blasting), by mordanting in chromic acid or by plasma treatment with an oxidizing agent of the air, or O₂ type or even a NH₃ type reducing agent. At the same time, superficial oxidation of almost all metals tends to reduce the adhesion of the polymer. Heating the metal in an inert atmosphere or by induction proves to be necessary in order not to modify the surface energy of the support. Finally, the cooling must be sufficiently slow to result in good re-crystallization, and to conserve the intrinsic properties of the polymer, such as wear resistance and scratch resistance. Rapid cooling would produce an amorphous coating which could still be re-crystallized by annealing the parts at 200°C for 30 minutes. The mechanical properties of the polymer may be increased by increasing the crystallinity by means of a controlled cooling process, for example with a cooling rate of 10°C/min from 400°C to 250°C followed by a constant temperature stage of 30 minutes to 1 hour at 250°C.

In a first stage, the Applicant investigated obtaining a polyaryletherketone coating from an aqueous suspension of polyetheretherketone sold by Victrex under the Vicote F800 series name which can contain at least one solid lubricant, preferably a fluorinated polymer of the perfluoroalkoxyethylene copolymer resin type to strengthen the wear resistance and/or at least one inorganic carbon black type solid compound to strengthen the abrasion resistance. The physic-chemical characteristics of the various aqueous phase Vicote F800 series suspensions are evaluated in Table 2.

el

Physico-chemical characteristics	Vicote F804	Vicote F805	Vicote F807Blk
Appearance	White liquid	White liquid	Black liquid
Solids (% by wt)	37	37	37
pH	6	5.5	5.5
ISO viscosity 6 mm (second)	55	55	30
Particle size (D90 diameter)	10 μm	10 μm	10 μm
Melting point ($^{\circ}\text{C}$)	343	343	343
Continuous service temperature ($^{\circ}\text{C}$)	260	260	260
Perfluoroalkoxyethylene copolymer resin (PFA)	-	10% of solids	30% of solids
Inorganic compound	-	-	Carbon black

Table 2

The Applicant has also accurately determined the composition of aqueous suspensions of polyetheretherketone powder. In particular, it was established that the aqueous suspensions may preferably comprise in the range 25% to 35% by weight of a PEEK powder with a particle size

5 D90 of 10 μm sold by Victrex under the trade name Vicote 704.

The aqueous suspensions may also comprise solid lubricant particles from at least one of classes 1, 2 and 4 and preferably in the range 3% to 12% by weight of a solid lubricant from class 4 in the form of a fluorinated powder of the perfluoroalkoxyethylene copolymer type sold by DYNELON under the trade name Hyflon® PFA with a mean particle size in the range 20 to 30

10 μm .

The term "solid lubricant" as used here means a solid and stable body which, on being interposed between two frictional surfaces, can reduce the coefficient of friction and reduce wear and damage to the surfaces. These bodies can be classified into different categories defined by their functional mechanism and their structure, namely:

- 15
- class 1: solid bodies owing their lubricating properties to their crystalline structure, for example graphite, zinc oxide (ZnO) or boron nitride (BN);
 - class 2: solid bodies owing their lubricating properties to their crystalline structure and also to a reactive chemical element in their composition, for example molybdenum

disulphide MoS_2 , graphite fluoride, tin sulphides, bismuth sulphides, tungsten disulphide, or calcium fluoride;

- class 3: solid bodies owing their lubricating properties to their chemical reactivity, for example certain chemical compounds of the thiosulphate type, or Desilube 88® sold by Desilube Technologies Inc;
- class 4: solid bodies owing their lubricating properties to a plastic or viscoplastic behaviour under frictional stress, for example polytetrafluoroethylene (PTFE) or polyamides.

The aqueous suspensions may comprise mechanical reinforcing agents, preferably in the range 0.5% to 1% by weight of carbon black pigments sold by Evonik under the trade name Printex with a BET specific surface area in the range 25 to 300 m^2/g and a mean particle size in the range 1 to 5 μm .

The aqueous suspensions may comprise a coalescing agent, preferably with a rapid evaporation rate and a boiling point in the range 100°C to 200°C, of the ethylene glycol mono-butyl ether type, in the range 2.5% to 10% by weight and more preferably in the range 2.5% to 5% by weight of the suspension in order to facilitate coalescence or formation of a film by external plastification of the polymer entities and to modify the surface tension of the suspension in order to facilitate spreading.

The aqueous suspensions may comprise a surfactant, and preferably a non-ionic wetting and dispersing agent of the sodium dioctylsulphosuccinate type (a compound of sulphuric acid and an aliphatic ester in a mixture of water and ethanol) in the range 2.5% to 10% by weight and preferably in the range 2.5% to 5% by weight of the suspension in order to improve wetting of the support and prevent the powders from settling out of the solution.

Regarding the process for depositing a dry film on the portion of the end 1, 2 of the threaded tubular component, the Applicant has established that the Vicote 704

polyetheretherketone powder grade may be applied by projection using an electrostatic gun using either a dry or wet procedure.

In a first variation, the portion of the end 1,2 is pre-heated to 400°C before applying the PEEK powder. Next, the coated portion is maintained at a temperature in the range 360°C to 5 420°C for 2 minutes and preferably at the initial temperature of 400°C to generate a good surface appearance. The operation may be repeated several times in order to produce the desired thickness. The powder must have been dehydrated for a minimum of 2 h at 180°C.

In a second variation, the portion of the end 1, 2 is coated by pneumatic spraying of a cold aqueous suspension of Vicote 704 powder which may or may not have been reinforced. For 10 this process, it is preferable for the portion of the end 1, 2 to be perfectly clean and degreased using a solvent, preferably a polar aprotic solvent such as acetone.

Application may be carried out using a pneumatic gun spraying system with a gravity feed gun and cup, the portion of the end 1, 2 being at ambient temperature. The temperature of the mixture is preferably close to the ambient temperature, said ambient temperature preferably 15 being in the range 20°C to 30°C.

The diameter of the gun nozzle is preferably in the range 0.7 to 1.8 mm and the minimum air pressure of 4 bars is preferably in the range 4 to 6 bars.

The coated part is then left at ambient temperature for a period in the range 5 to 10 minutes.

20 The part is placed in an oven or furnace at a temperature of 120°C for a period in the range 5 to 10 minutes. This drying operation may be carried out by induction, for example. Next, the part is placed in a furnace either at 400°C or at a lower temperature, followed by raising it to 400°C at a rate in the range 10°C to 20°C/min.

25 Once the maximum temperature of the metal has been reached, the portion of the threaded end 1, 2 is left at this temperature for 5 to 15 minutes and preferably for at least 10 minutes in order to allow the dry film to fuse completely and form a homogeneous film.

The threaded end portion 1, 2 is then taken out of the furnace and allowed to cool to ambient temperature. The cooling rate is preferably slow, namely in the range 1°C/min to 200°C/min in order to obtain a semi-crystalline structure.

5 An alternative to electrostatic projection consists of applying a Vicote powder by dry thermal projection onto the portion of the threaded end 1, 2 using a heat gun. In this process, it is preferable for the portion of the end 1, 2 to be perfectly clean and degreased with a solvent, preferably a polar aprotic solvent such as acetone.

10 The part is pre-heated in an oven or furnace at 260°C. The Vicote powder is applied to the part using a heat gun with a vector gas allowing the fine particles of polyaryletherketone to be heated to the melting point, accelerated and transported to the substrate. The operation is followed by rapid cooling in air to ambient temperature. The operation may be repeated several times in order to obtain the desired thickness.

The thickness of the dry coating is in the range 20 to 70 µm, preferably in the range 30 to 50 µm.

15 The tests consist of evaluating a certain number of parameters, namely:

- the frictional torque at the surfaces in contact under high Hertz stresses (Bridgman test);
- the adhesive force of the film on the substrate (Scratch test, cross hatch test);
- the wet medium exposure resistance;
- 20 • the water immersion resistance;
- the high pressure wear resistance (Falex test).

The Bridgman test enables to determine the tribological characteristics of dry film pigments during a screwing operation specific for "premium" connections. More precisely, the torque on shoulder resistance CSB, also known as the ToSR (torque on shoulder resistance), is 25 simulated and determined. This torque arises during screwing operations specific for premium connections used in the oil industry and represented in Figure 2.

RL

The curve in Figure 2 expresses the screwing (or clamping) torque as a function of the number of rotational turns made. As can be seen, a profile for the screwing torque of "premium" connections breaks down into four portions.

In a first portion P1, the external threads of the male threaded element (or pin) of a first component of a threaded tubular connection as yet have no radial tightening with the internal threads of the corresponding female threaded element (or box) of a second component of the same threaded tubular connection.

In a second portion P2, the geometrical interference of the threads of the male and female threaded elements generates a radial tightening which increases as screwing continues (generating a small but increasing screwing torque).

In a third portion P3, a sealing surface at the external periphery of the end portion of the male threaded element interferes radially with a corresponding sealing surface of the female threaded element to produce a metal/metal seal.

In a fourth portion P4, the front end surface of the male threaded element is in axial abutment with the annular surface of a makeup abutment of the female threaded element. This fourth portion P4 corresponds to the terminal phase of makeup.

The makeup torque CAB which corresponds to the end of the third portion P3 and to the start of the fourth portion P4 is termed the shouldering torque.

The makeup torque CP which corresponds to the end of the fourth portion P4 is termed the plastification torque. Beyond this plastification torque CP, it is assumed that the male makeup abutment (end portion of the male threaded element) and/or the female makeup abutment (zone located behind the annular abutment surface of the female threaded element) is (or are) subjected to plastic deformation, which may degrade performance as regards the tightness of the contact between the sealing surfaces by plastification of the sealing surfaces as well.

q.l

The difference between the values for the plastification torque CP and the shouldering torque CAB is termed the torque on shoulder resistance CSB ($CSB = CP - CAB$). A threaded tubular connection is subjected to an optimum tightening at the end of makeup, which is the guarantee for optimum mechanical strength of the threaded connection, for example as regards
5 tensile forces, but also as regards accidental break-out in service, and for optimum sealing performances.

The designer of a threaded connection is thus obliged to define, for a given type of threaded connection, a value for the optimum makeup torque which, for all connections of this type of connection, must be lower than the plastification torque CP (in order to avoid
10 plastification of the abutments and the resulting disadvantages) and be higher than the shouldering torque, CAB . Ending makeup with a torque which is less than CAB cannot guarantee correct relative positioning of the male and female elements and thus of an efficient interference fit between their sealing surfaces. Furthermore, there is a risk of break-out. The effective value of the shouldering torque CAB fluctuates greatly from one connection to another
15 for the same type of connection as it depends on the diametral and axial machining tolerances of the male and female threads and sealing surface(s); the optimal makeup torque should be substantially higher than the shouldering torque CAB .

As a consequence, the higher the value of the torque on shoulder resistance CSB , the larger the margin for defining the optimized makeup torque, and the more the threaded
20 connection will be resistant to operational stresses.

Friction tests were carried out using a Bridgman type machine. This type of machine has in particular been described in the article by D Kuhlmann-Wilsdorf et al, "Plastic flow between Bridgman anvils under high pressures", J. Mater. Res., vol 6, no 12, Dec 1991. A diagrammatic and functional example of a Bridgman machine is illustrated in Figure 5.

25 This machine comprises: a disk DQ which can be driven in rotation at selected speeds; a first anvil $EC1$, preferably conical in type, permanently attached to a first face of the disk DQ ; a

B.L

second anvil EC2, preferably conical in type, permanently attached to a second face of the disk DQ, opposite its first face; first EP1 and second EP2 pressure elements, such as pistons, for example, which can exert the selected axial pressures P; a third anvil EC3, preferably cylindrical in type, which is permanently attached to one face of the first pressure element EP1; a fourth
5 anvil EC4, preferably cylindrical in type, which is permanently attached to one face of the second pressure element EP2.

To test a lubricant composition, two pieces of a material identical to that constituting a threaded element are covered with said composition in order to form the first S1 and second S2 specimens. Next, the first specimen S1 is interposed between the free faces of the first EC1 and
10 third EC3 anvils, and the second specimen S2 between the free faces of the second EC2 and fourth EC4 anvils. Next, the disk DQ is rotated at a selected speed while applying a selected axial pressure P (for example of the order of 1 GPa) with each of the first EP1 and second EP2 pressure elements, and the makeup torque to which each specimen S1, S2 is subjected is measured. The axial pressure, the rotation speed and the angle of rotation are selected in the
15 Bridgman test in order to simulate the Hertz pressure and the relative speed of the abutment surfaces at the end of makeup. Using such a machine, it is possible to fix several different pairings of parameters (makeup torque, rotation speed) in order to impose predetermined makeup torques on specimens S1 and S2, and thus to check whether these specimens S1 and S2 closely follow a given makeup torque profile, and in particular whether they can reach a number of
20 completed turns before galling which is at least equal to a threshold value selected with respect to the selected makeup torques.

In the present case, the selected contact pressure was 1 GPa and the rotation speed was 1 rpm. The test specimens were formed from stainless steel containing 13% Cr, machined then coated with different dry film formulations.

25 The Scratch test, shown diagrammatically in Figure 4, allows the adhesive force or adhesion of a film on a surface or surface preparation to be determined. The method, consisting

of shearing and deforming a film with a spherical bead subjected to an increasing load, also allows two major tribological parameters to be determined, namely the coefficient of friction and the critical load corresponding to the appearance of a loss of film cohesion.

The experimental conditions employ a spherical indenter formed from Inconel 718 with a diameter of 5 mm and a metal specimen formed from XC48 carbon steel which had been treated by zinc or manganese phosphatation or an electrolytic Cu-Sn-Zn deposit. The parameters were: a load increasing from 10 N to 310 N at a load increase rate of 15 N/s or a load increasing from 250 N to 750 N at a load increase rate of 25 N/s. The bead displacement rate was 2 mm/s for a period of 20 s (the track length was 40 mm). The measured coefficient of friction is considered to be low when it is in the range $\mu = 0.05$ for a load of 10 N and $\mu = 0.09$ for a load of 310 N. A μ of 0.07 was measured for a load of 310 N on a carbon steel surface. It should be noted that it is necessary to clearly set out the load and operating conditions for the test for each type of coating.

The cross hatch test consists of evaluating the resistance of a mono- or multi-layer coating to being separated from a substrate when the coating is cross-hatched by making incisions until said substrate in accordance with a classification into six categories. Excellent adhesion of the coating to the substrate must correspond to class 0 of ISO standard 2409 (2007): perfectly smooth edges to the incisions, none of the cross hatch squares detached. In order to take the environment into account, the cross hatch test is carried out after being placed in a moist medium (35°C and 90% RH). No change in appearance, no blistering no corrosion, no cracking, no scaling corresponding to the classifications in ISO standard 4628, and no loss of adhesion are characteristics of good moisture resistance.

The corrosion tests consist of a neutral salt spray test carried out in a climatic chamber under the following conditions: 35°C with a 50 g/L salt solution with a density in the range 1.029 to 1.036 at 25°C, with a pH in the range 6.5 to 7.2 at 25°C and recovered at a mean rate of 1.5 mL/h.

sh L

Specimens that were intact without rusting then had to correspond to the ReO class of ISO standard 9227 after exposure. The method provides a means of verifying that the comparative quality of a metallic material with or without a corrosion protective coating (metallic or organic coating on metallic material) is maintained.

5 The water resistance tests consist of subjecting the specimens to an accelerated corrosion test in accordance with DIN standard 50017 carried out in a climatic chamber. This test, comprising one cycle per day, consists of depositing water vapour by condensation under the following conditions: 35°C, 90% relative humidity (RH) for 8 hours, then allowing the specimen to dry. After 7 cycles, a check is made to see whether the substrate protected by the coating has
10 corroded.

Excellent resistance must correspond to the classifications in ISO standard 4628: no corrosion, no blistering, no cracking, nor scaling of a chromium or carbon steel plate treated or not treated by phosphatation with zinc (8 to 20 g/m² deposit of phosphate) or manganese or treated by an electrolytic deposit of a ternary Cu-Sn-Zn alloy with an intermediate layer of Ni.

15 The water immersion test is much more severe than the water resistance test of DIN standard 50017. It consists of testing the water resistance of the coatings. It is derived from ASTM standard D870-09 relating to industrial and automobile paints.

Immersion in water may cause coatings to degrade. Knowledge regarding the manner in which a coating resists immersion in water is useful for predicting its service life. Rupture or
20 failure in a water immersion test may be caused by a number of factors, in particular a deficiency in the coating itself, contamination of the substrate, or insufficient surface preparation. Thus, the test is useful for evaluating the coatings alone or complete coating systems.

The test consists of half immersing a specimen in demineralized water for a period of 168 hours at 40°C in an oven. Adhesion, blistering, rust, or blowholes are observed visually to
25 indicate the sensitivity of the coating to water.

The high pressure wear resistance (also termed the Falex test) uses a rotating indenter compressed between two V-shaped blocks as described in Figure 6. The Falex test is used in particular at high speeds to evaluate anti-wear and extreme pressure properties of lubricant fluids in accordance with ASTM standard D 2670 and ASTM D 3233, but it is also used at low speeds to evaluate solid lubricants in accordance with ASTM method D 2625. The Falex test is adapted to accommodate threaded connections used in working hydrocarbon wells in that it uses:

- a semi-closed contact geometry (to trap a third lubricating body);
- a pressure-speed range which matches up with that of the connections;
- the possibility of carrying out single direction or alternating tests in order to simulate make up and break out type operations.

The test conditions are as follows:

- load = 785 N;
- rotational speed of indenter = 60 rpm;
- mean metal/metal contact pressure = 560 MPa;
- indenter sliding speed = 20 mm/s.

The aim of this test is to simulate and evaluate endurance in terms of galling resistance for the various films without the need to carry out the evaluation on connections. This test means that the performance of the various coatings can be compared with actual tests on the connection. The galling criterion is defined using ASTM standard D 2625-94 relating to the measurement of the loading capacity of the solid lubricant film and corresponds to a sharp increase of the torque compared with the initial state of the order of 1130 N.mm or of the coefficient of friction of the order of 0.15 for a load of 785 N. In general, galling is observed when the applied load decreases irrespective of the materials and configuration.

The Applicant has evaluated the performance, especially tribo-rheological performance, of various films obtained with aqueous suspensions of polyetheretherketone in order to compare

RL

them, inter alia, with those observed with a thermoset film of the fluoroethane type or a viscoplastic film with a waxy thermoplastic matrix.

The fluoroethane film consists of an aqueous dispersion of fluoroethylenevinylether cured using an aliphatic polyisocyanate hardener.

5 The waxy thermoplastic matrix comprises at least one polyethylene wax and mainly an overbased calcium sulphate in which friction modifying pigments are dispersed, as described in patent WO 2008/139058.

In a first stage, the Applicant evaluated the adhesion, the coefficient of friction, the anti-corrosion protection and the water immersion characteristics of aqueous suspensions of polyetheretherketone on various substrates that had received a particular surface preparation
10 treatment:

- as-machined XC48 carbon steel (XC48 AsM);
- Z20C13 stainless steel (13Cr);
- XC48 carbon steel with zinc (PhZn) or manganese (PhMn) phosphatation;
- 15 • XC48 carbon steel with electrolytic Cu-Sn-Zn deposit (TA).

Tables 3, 4 and 5 summarize the adhesion results obtained respectively for aqueous suspensions of Vicote F804, Vicote F805 and Vicote F807Blk on specimens that have received different surface preparations by means of the Scratch test and by means of the cross hatch test in accordance with ISO standard 2409.

20 It will be recalled herein that the Scratch test characterizes the adhesive force of a high performance material, preferably thermoset or thermoplastic, as a function of an increasing applied load. The critical load, determining rupture at the interface and thus the adhesive force of the material, is higher when the material is resistant and adhesive. A minimum critical load of 310 N corresponds to a minimum adhesion for pressures which may reach 1.1 GPa below which
25 an increase in the quantity of wear product occurs in the contact and thus galling resistance is insufficient.

31

For the cross hatch test in accordance with ISO standard 2409, which provides a measurement of the adhesion after damage by Scratching the material to the interface, a mark of 0 corresponds to excellent adhesion while a mark of 5 defines very poor adhesion.

Surface preparation	XC48 AsM	PhMn	TA
Adhesion, Scratch test (Lc, in N)	242	750	400
Adhesion, ISO 2409	0	0	0

Table 3: adhesion performance of Vicote F804

Surface preparation	XC48 AsM	13Cr	PhMn	TA
Adhesion, Scratch test (Lc, in N)	253	246	750	294
Adhesion, ISO 2409	0	0	0	0

5 Table 4: adhesion performance of Vicote F805

Surface preparation	XC48 AsM	13Cr	PhZn	PhMn	TA
Adhesion, Scratch test (Lc, in N)	750	254	50	750	188
Adhesion, ISO 2409	0	0	5	0	0

Table 5: adhesion performance of Vicote F807Blk

The films tested had insufficient adhesive forces irrespective of the surface preparation carried out on carbon steels with zinc phosphatation, except for carbon steels with manganese phosphatation. In addition, the polyetheretherketone film had little compatibility with a zinc phosphatation type surface treatment.

In order to explain these results, the Applicant also evaluated the incidence of roughness obtained without phosphatation. Since the adhesion mechanism for a polyetheretherketone film is principally physical by mechanical keying, the roughness of the substrate is a determining factor.

At the same time, it is recommended to sand the substrate by projection in order to obtain a roughness Ra (Ra being the arithmetic mean with respect to the mean line for the amplitude of the roughness) of 20% or 25% of the thickness of the desired final film in order to ensure good adhesion of the film i.e. a roughness Ra in the range 4 μm to 6 μm minimum. The roughness was determined using a rugosimeter in accordance with ISO standard 1997.

Surface preparation	XC48 AsM	13Cr	PhZn	PhMn	TA
Ra (μm)	0.9 \pm 0.05	0.09	0.8 \pm 0.05	1.6 \pm 0.1	1 \pm 0.2
Rz (μm)	4.8 \pm 0.2	0.9 \pm 0.1	5.1 \pm 0.3	11.1 \pm 1.0	8 \pm 1.4

Table 6: roughness of test specimens as function of surface preparation

62

Table 6 illustrates that a relatively high roughness obtained by manganese phosphatation offers a better degree of adhesion. It also shows that very slightly polar surface preparations, such as the electrolytic deposition of ternary Cu-Sn-Zn, do not facilitate adhesion.

In view of these first results, the Applicant elected, to determine the corrosion resistance, only substrates with naturally low resistance to corrosion, thereby excluding martensitic stainless steel containing 13% chromium for which the critical adhesion load for polyetheretherketone films was more than 180 N.

The thicknesses of films produced by cold pneumatic spraying were in the range 20 to 45 μm . The degree of rusting in the range Re0 and Re9 was determined in accordance with ISO standard 4528-3. The degree of blistering and detachment in the range 2S2 (low concentration of blistering and of small dimensions) and 5S5 (generalized blistering and of large dimensions) was determined in accordance with ISO standard 4628-2. The results are summarized in Tables 7 and 8.

Surface preparation	Exposure time				
	24 h	48 h	250 h	750 h	1000 h
XC48 AsM	Re9	-	-	-	-
TA	Re2	Re3/4+ Detachment	-	-	-

Table 7: corrosion resistance for different surface preparations with Vicote F805

Surface preparation	Exposure time				
	24 h	48 h	250 h	750 h	1000 h
XC48 AsM	Re8	Re9	-	-	-
PhMn	Re1	Re2	Re3	-	-
TA	Re0	Re0	Re1	Re1	Re1/2 + detachment

Table 8: corrosion resistance for different surface preparations with Vicote F807Blk

The corrosion resistance of surface preparations coated with the monolayer polyetheretherketone film was broadly insufficient except for the Cu-Sn-Zn electrolytic deposit, despite the low adhesion or strong loss of cohesion of the film under stress. The results also show that the Vicote F807Blk polyetheretherketone film comprising an inorganic carbon black type compound has relatively better corrosion resistance compared with Vicote F805 irrespective of the surface preparation. The absolute best result was obtained with the electrolytic deposit

hL

with only 5 spots of corrosion after 1000 hours. It was observed that adding an electrically conductive carbon black reinforcing agent reinforced the mechanism for protection against corrosion by acting as a sacrificial anode.

Finally, the Applicant evaluated the mean coefficients of friction of a film subjected to abrasive wear by means of a Scratch test over a wide load range between 10 N and 750 N. The results are summarized in Table 9.

Film Surface preparation	Vicote F804		Vicote F805		Vicote F807Blk			
	XC48 AsM	TA	XC48 AsM	TA	XC48 AsM	13Cr	PhMn	TA
Mean CoF (10-310 N)	0.198	0.173	0.069	0.075	0.073	0.112	0.135	0.127

Table 9: mean coefficient of friction, Scratch test

The coefficients of friction of the polyetheretherketone films were less than 0.135 irrespective of the surface preparation and reached 0.075 for a mean contact pressure of 500 MPa for a polyetheretherketone comprising a fluorinated polymer of the perfluoroalkoxyethylene type.

The first results show that monolayer polyetheretherketone films are sufficiently lubricating with an anti-corrosion performance which depends not only on the composition of the film but also on the adhesion of the substrate.

In a second stage, the Applicant then developed a means for improving the adhesion and the anti-corrosion performance. The Applicant wanted to replace sanding when this was not possible due to the geometry of the parts to be coated. Above all, the Applicant investigated not modifying the composition of the commercial films studied. In fact, adding adhesion promoters or corrosion inhibiting pigments in proportions of more than 10% increases the PCV (pigment concentration by volume) beyond the PCV for which there is just enough binder to coat the powdered substances (pigments and fillers) and as a result the porosity and loss of cohesion of the film obtained from commercially available aqueous suspensions.

Other alternatives using Vicote 704 polyetheretherketone powder may also be foreseen.

The Applicant investigated increasing the adhesion with an undercoat of the adhesion promoter type. Direct adhesion between materials is rare. Since direct adhesion is principally

but not uniquely linked to Van der Waals interactions, it only occurs with very smooth materials which are extremely clean (mica or silicon, for example), which are brought into intimate contact, i.e. to within distances on the atomic scale (nanometric). Thus, this is often impossible to carry out if the surfaces are rough, but in contrast is entirely suitable for films with low
5 roughness.

Thus, the Applicant principally investigated a film compatible with the process for obtaining a polyetheretherketone film by melting at 400°C.

The undercoat may be a projected deposit of alloys of iron and zinc, sold under the trade name Dacroforge Z by Dacral to replace zinc phosphatation, but the process for obtaining it by
10 mechanical projection equivalent to sanding/shot blasting limits its use in hollow bodies which have small diameters and are short in height.

The undercoat is preferably a filled polyaryletherketone. The solution comprising, inter alia, mica pigments of the muscovite or biotite type in proportions of 25% to 50% by weight in an organic polyetheretherketone binder is sold under the trade name Vicote F817 by the supplier
15 Victrex.

The process for application and melting the undercoat is identical to that for the upper layer. In contrast, a rapid cooling rate is desired in order to obtain a less crystalline structure that is more insulating in order to retard the initiation of corrosion pits and to reduce the passive current density of the material.

20 The thickness of the undercoat may be in the range 30 to 40 µm.

The anti-corrosion and adhesion properties of the undercoat evaluated using two processes with different cooling kinetics are summarized in Tables 10 and 11 respectively.

HL

Surface preparation	Cooling kinetics	Exposure time						
		24 h	48 h	250 h	500 h	750h	1000 h	1500 h
XC48 asM	120°C/min	Re0	Re0	Re0	Re0	Re0	Re0 + 2S2 blistering	Re0/1+ 2S2 blistering
TA	120°C/min	Re0	Re0	Re0	Re0	Re0	Re0 + 2S2 blistering	Re0 + detachment
XC48 asM	400°C-260°C 15mn at 260°C 260°C-T amb	Re0	Re0	Re0	Re0	Re0	Re0/1 + 3S2 blistering	Re0/1 + 3S3 blistering
TA	400°C-260°C 15mn at 260°C 260°C-T amb	Re0	Re0	Re0	Re0	Re0	Re0/1 + 3S2 blistering	Re0/1 + 3S3 blistering

Table 10: corrosion resistance for different surface preparations with Vicote F817 undercoat

Surface preparation	XC48 asM	TA
Adhesion, Scratch test (Lc, N)	350	344
Adhesion, ISO 2409	0	0
Mean COF (10-310 N)	0.164	0.160

Table 11: adhesion performances and coefficient of friction for Vicote F817 .

The Vicote F817 undercoat was sufficiently protective and adhesive but not sufficiently lubricating. The lubricating properties were supplied by the upper polyaryletherketone layer.

The anti-corrosion, adhesion and double layer friction performances are summarized in Tables 12 and 13. The total thickness of the film comprising the undercoat and the upper layer (topcoat) was in the range 40 to 70 μm .

Topcoat	Undercoat	Surface preparation	Exposure time						
			24 h	48 h	250 h	500 h	750h	1000 h	1500 h
Vicote F807Blk	Vicote F817	XC48 asM	Re0	Re0	Re0	Re0	Re0	Re0 + 2S2 blistering	Re0/1+ 2S2 blistering
		PhMn	Re0	Re0	Re0	Re0	Re0	Re0	Re0
		TA	Re0	Re0	Re0	Re0	Re0	Re0 + 2S2 blistering	Re0 + detachment
	Dacroforge Z	XC48 asM	Re2	Re4	-	-	-	-	-

Table 12: corrosion resistance for different double layer surface preparations

Topcoat	Vicote F804		Vicote F805	Vicote F807 Blk			
Undercoat	Vicote F817						Dacro-forge Z
Surface preparation	XC48 asM	TA	XC48 asM	XC48 asM	PhMn	TA	XC48 asM
Scratch adhesion test (Lc, N)	441	662	>750	675	637	>750	>750
Adhesion, ISO 2409	0	0	0	0	0	0	0
Mean COF (10-310 N)	0.117	0.114	0.061	0.086	0.085	0.084	0.129

Table 13: adhesion performance and double layer coefficient of friction

The coefficients of friction for a mean contact pressure of 500 MPa were sufficiently low, particularly for the Vicote F807 Blk film wherein $\mu = 0.085$ irrespective of the surface preparation, and are comparable to the coefficients of friction for a fluoroethane or epoxide thermoset film, and must allow a shouldering torque value of less than 70% of the optimum makeup torque to be obtained.

Overall, the coefficient of friction, the adhesion and the anti-corrosion protection of the polyetheretherketone film are considerably improved, preferably with a polyetheretherketone undercoat with mica pigment filler and more particularly an upper layer of polyetheretherketone comprising at least one fluorinated polymer that deforms plastically under stress and/or a carbon black type mechanical reinforcing pigment.

Finally, the Applicant evaluated the tribo-rheological behavior of the film by means of a Bridgman test in order to determine the value of the torque on shoulder resistance. The torque on shoulder resistance value obtained for Vicote F807 Blk was equal to 85% of the reference value for API RP 5A3 grease on XC48 carbon steel and Z20C13 stainless steel. However, the difficulty in preparing the specimens due to the process for producing the film and the small diameter of the specimens meant that this value cannot be considered to be an absolute reference. The crystalline structure and many potential Van der Waals type intermolecular interactions in

✓

the polyetheretherketone point to the strong cohesion of the material and a high shear strength, and thus probably to a substantially higher torque on shoulder resistance value.

At the same time, the Applicant evaluated the galling resistance of the film by means of a Falex test. The configuration of a test matched to a connection may comprise a pair of V shaped
5 blocks, Vee blocks, with different surface preparations coated with PEEK film in a mono or double layer and an as machined XC48 carbon steel indenter or Z20C13 stainless steel indenter containing 13% chromium.

The test conditions using a load of 785 N correspond to a mean pressure in the contact of 150 MPa which is relatively close to that recorded during screwing at the start of shouldering at the
10 threads and the bearing surface (100-300 MPa) and a pressure-velocity modulus (PV) = 11.2 MPa.m/s which is close to that establishing the wear law in the threading at the load flanks with PV = 5 MPa.m/s.

The Applicant studied Vicote F805 and F807Blk reinforced polyetheretherketones.

Figure 6 shows the very good endurance of the double layer Vicote F817/Vicote F807 Blk
15 film compared with the waxy thermoplastic solution in current use on the connection and despite a ternary electrolytic deposit type surface treatment considered to be anti-galling (see document WO 2008/032872). Galling, defined in accordance with ASTM standard D 2625-94, was never obtained, while it was obtained with the HMS3 waxy thermoplastic solution after 51 minutes. The relatively low and constant coefficient of friction, $\mu = 0.08$, characterized very low abrasive wear.

20 In order to determine the limits to the galling resistance of the film below, the Applicant evaluated the endurance and the coefficient of friction of the film using the Falex test for increasing loads in the range 1335 N to 4200 N. The sliding speed was 10 mm/s, as opposed to the 20 mm/s employed before. The results are shown in Figure 7.

The results show that galling does not occur for mean contact pressures of 350 MPa and
25 confirm the very high wear resistance of the film for the present invention. The coefficient of friction also decreased as the pressure increased and was in the range 0.056 to 0.078.

In order to confirm the galling resistance and the coefficient of friction observed in the laboratory using the Falex and Scratch test on specimens, in particular of carbon steel with an electrolytic Cu-Sn-Zn deposit, the Applicant carried out makeups on 7" 29# L80 VAM TOP HT connections, which are highly sensitive to galling. The makeup torque was 29900 N.m.

- 5 The female end 2 of carbon steel was treated by electrolytic deposit and the male end 1 was treated by zinc phosphatation and coated with a UV curable acrylic resin described in patent publication WO 2006/104251. The double layer PEEK film was applied to the treated coupling with a cooling rate of less than 5°C/min. Table 14 summarizes the makeup results.

Product name	Number of makeup procedures without galling	Ratio of 1 st shouldering torque compared with respect to makeup torque	No of makeups with shouldering torque <70% of makeup torque
Vicote F807 Blk	17	57%	10

Table 14: comparison of 7" 29# L80 VAM TOP HT-CW UD makeup results

- 10 The makeup results obtained confirm the remarkable anti-galling nature of polyetheretherketone film and in particular reinforced polyetheretherketone film.

Female end	Male end	Number of makeups without galling
Carbon steel + electrolytic Cu-Sn-Zn deposit + PEEK double layer	Carbon steel + zinc phosphatation + UV acrylic resin	17

Table 15: results of 7" 29# L80 VAM TOP HT makeups

- 15 Thus, the present invention proposes a lubricant film having very interesting galling resistance properties when it is applied to a carbon steel surface or steel surface comprising at least 13% chromium. It also allows the use of electrolytic deposits of the binary Cu-Sn or ternary Cu-Sn-Zn type to be dispensed with.

04 AVR. 2013

CABINET CAZENAVE sarl
 Propriété Industrielle
 B.P. 500 YAOUNDE Cameroun
 Tél. 22 21 32 89 - Fax: 22 20 64 14
 E-mail: cabinetcazenave@iccnet.cm

CLAIMS

1. A threaded tubular component for drilling or working hydrocarbon wells, said tubular component having at one of its ends (1; 2) a threaded zone (3; 4) produced on its outer or inner peripheral surface depending on whether the threaded end is male or female in type,
5 characterized in that at least a portion of the end (1; 2) is coated with at least one lubricating dry film (12) comprising at least 65% by weight of a polyaryletherketone.
2. A threaded tubular component according to claim 1, characterized in that the polyaryletherketone is selected from a polyetheretherketone (PEEK), a polyetherketone (PEK) and mixtures thereof.
- 10 3. A threaded tubular component according to claim 1 or claim 2, characterized in that the lubricating dry film (12) has a structure with a degree of crystallinity in the range 10% to 35%.
4. A threaded tubular component according to any one of the preceding claims, characterized in that the lubricating dry film (12) further comprises at least one class 4 solid
15 lubricant in a proportion by weight in the range 10% to 35%.
5. A threaded tubular component according to claim 4, characterized in that the lubricating dry film (12) comprises a perfluoroalkoxyethylene copolymer in a proportion by weight in the range 10% to 30%.
6. A threaded tubular component according to any one of the preceding claims,
20 characterized in that the lubricating dry film (12) comprises a mechanical reinforcing agent selected from the list of the following pigments: carbon black, mica, wollastonite, nanometric aluminium oxide, nanometric titanium oxide, glass powders, nano-diamond, nanometric WS2 or WS2-fullerenes, in a proportion by weight in the range 1% to 15%.
7. A threaded tubular component according to any one of the preceding claims,
25 characterized in that the portion coated with lubricating dry film (12) has previously undergone a surface preparation step selected from the group constituted by sanding,

BL

manganese phosphatation, electrolytic deposition of Cu or Cu-Sn-Zn alloys, and Fe and Zn alloys deposited by projection.

8. A threaded tubular component according to any one of claims 1 to 6, characterized in that the portion coated with lubricating dry film (12) has previously been coated with an undercoat of polyetheretherketone with a semi-crystalline structure and containing mica pigments.
9. A threaded tubular component according to any one of the preceding claims, characterized in that the entire threaded zone (3; 4) is coated with lubricating dry film (12).
10. A threaded tubular component according to any one of the preceding claims, characterized in that it comprises a metal/metal sealing surface, said sealing surface being coated with lubricating dry film (12).
11. A threaded tubular connection comprising a male threaded tubular component and a female threaded tubular component made up one into the other, characterized in that at least one of said threaded tubular components is in accordance with one of the preceding claims.
12. A process for coating a threaded tubular component for drilling or working hydrocarbon wells, said tubular component having at one of its ends (1; 2) a threaded zone (3; 4) produced on its outer or inner peripheral surface depending on whether the threaded end is male or female in type, characterized in that the process comprises the following steps:
- producing a mixture comprising a polyaryletherketone powder in suspension in water, in proportions in the range 25% to 35% by weight;
 - applying said mixture to a portion of the end (1; 2) of said threaded tubular component;
 - drying the portion of the end (1; 2) thus coated at a temperature in the range 100°C to 150°C for a period in the range 5 to 10 minutes;

- heating the thus coated portion of the end (1; 2) to a temperature in the range 350°C to 450°C for 5 to 15 minutes at a rate of increase in temperature in the range 10°C to 20°C per minute;
 - cooling the thus coated portion of the end (1; 2) to ambient temperature at a cooling rate of less than 10°C per minute, in order to obtain a principally crystalline structure.
- 5
13. A process for coating a threaded tubular component according to claim 12, characterized in that the mixture also comprises a coalescing agent with a rapid evaporation rate with a boiling point in the range 100°C to 200°C and in proportions in the range 2.5% to 10% by weight.
- 10
14. A process for coating a threaded tubular component according to claim 12 or claim 13, characterized in that the mixture further comprises a non-ionic wetting and dispersing agent in proportions in the range 2.5% to 10% by weight.
15. A process for coating a threaded tubular component according to any one of claims 12 to 14, characterized in that the mixture also comprises at least one class 4 solid lubricant in proportions in the range 3% to 12% by weight.
- 15
16. A process for coating a threaded tubular component according to claim 15, characterized in that the class 4 solid lubricant is a perfluoroalkoxyethylene copolymer in a proportion by weight in the range 3% to 12%.
17. A process for coating a threaded tubular component according to claim 15, characterized in that the mixture also comprises a mechanical reinforcing agent selected from the list of the following pigments: carbon black, mica, wollastonite, nanometric aluminium oxide, nanometric titanium oxide, glass powders, nano-diamond, nanometric WS₂ or WS₂-fullerenes, in a proportion by weight in the range 0.5% to 5%.
- 20
18. A process for coating a threaded tubular component according to claim 12, characterized in that the portion of the end (1; 2) is coated using a pneumatic spray system, the diameter of
- 25

Bl

said system being in the range 0.7 to 1.8 mm and the air pressure being in the range 4 to 6 bars.

19. A process for coating a threaded tubular component according to any one of claims 12 to 18, characterized in that a surface preparation step selected from the group constituted by sanding, manganese phosphatation, electrolytic deposition of Cu or Cu-Sn-Zn alloys, and particles of Fe and Zn alloys deposited by projection is carried out before applying the mixture to the portion of the end.
20. A process for coating a threaded tubular component according to any one of claims 12 to 18, characterized in that a surface preparation step consisting of producing an undercoat of polyetheretherketone with a semi-crystalline structure and containing mica pigments is carried out before applying the mixture to the portion of the end.
21. A process for coating a threaded tubular component for drilling or working hydrocarbon wells, said tubular component having at one of its ends (1; 2) a threaded zone (3; 4) produced on its outer or inner peripheral surface depending on whether the threaded end is male or female in type, characterized in that it comprises the following steps:
- heating a portion of the end (1; 2) of said threaded tubular component to a temperature in the range 360°C to 420°C, preferably to a temperature close to 400°C;
 - projecting PEK and/or PEEK powders onto the portion of the end (1; 2) of said threaded tubular component;
 - maintaining the thus coated portion of the end (1; 2) at a temperature in the range 360°C to 420°C, preferably at a temperature close to 400°C, for a period in the range 1 to 4 minutes;
 - cooling the thus coated portion of the end (1; 2) to ambient temperature at a cooling rate of less than 10°C per minute, in order to obtain a principally crystalline structure.

g.l.

22. A process for coating a threaded tubular component according to claim 21, characterized in that a step for degreasing the portion to be coated is carried out before heating said portion.

34 pages

ml

ORIGINAL

1- VALLOUREC MANNESMANN OIL & GAS FRANCE

2- NIPPON STEEL & SUMITOMO METAL CORPORATION

PAR PROCURATION

04 AVR. 2013

CABINET CAZENAVE sarl
Propriété Industrielle
B.P 500 YAOUNDE Cameroun
Tél. 22 21 32 89 - Fax: 22 20 64 14
E-mail: cabinetcazenave@ccnet.cm

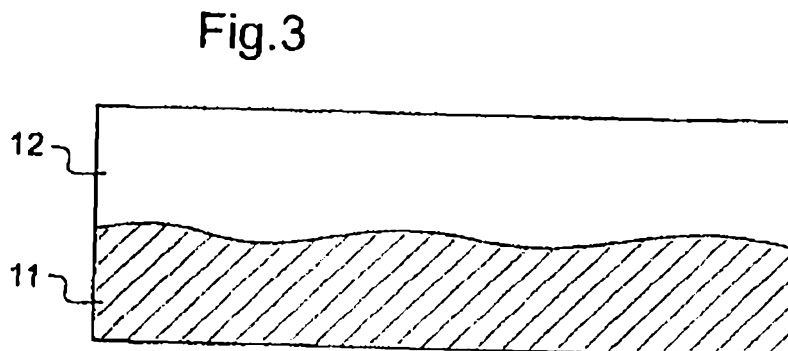
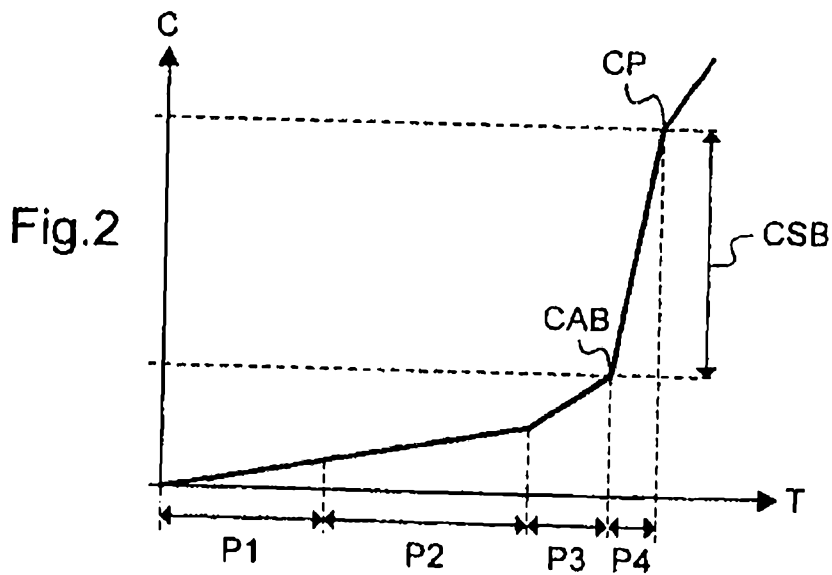
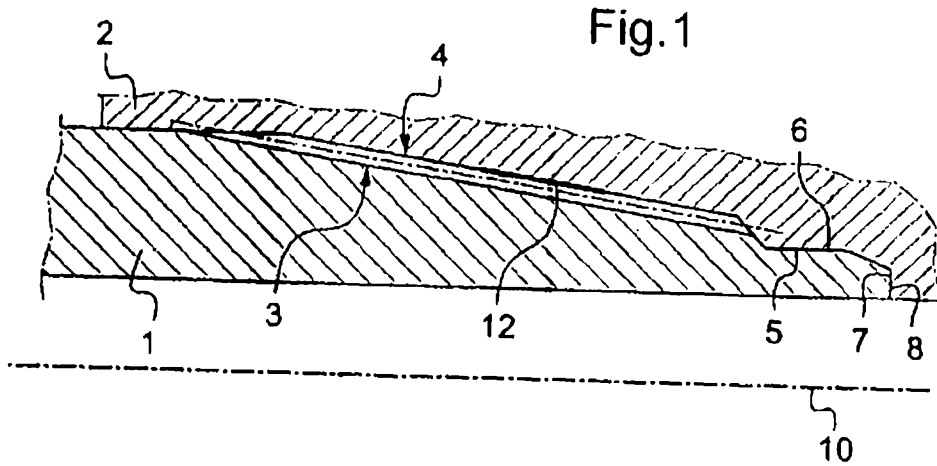

04 AVR. 2013

CABINET CAZENAVE sarl
Propriété Industrielle
B.P 500 YAOUNDE Cameroun
Tél. 22 21 32 89 - Fax: 22 20 64 14
E-mail: cabinetcazenave@iccnnet.cm

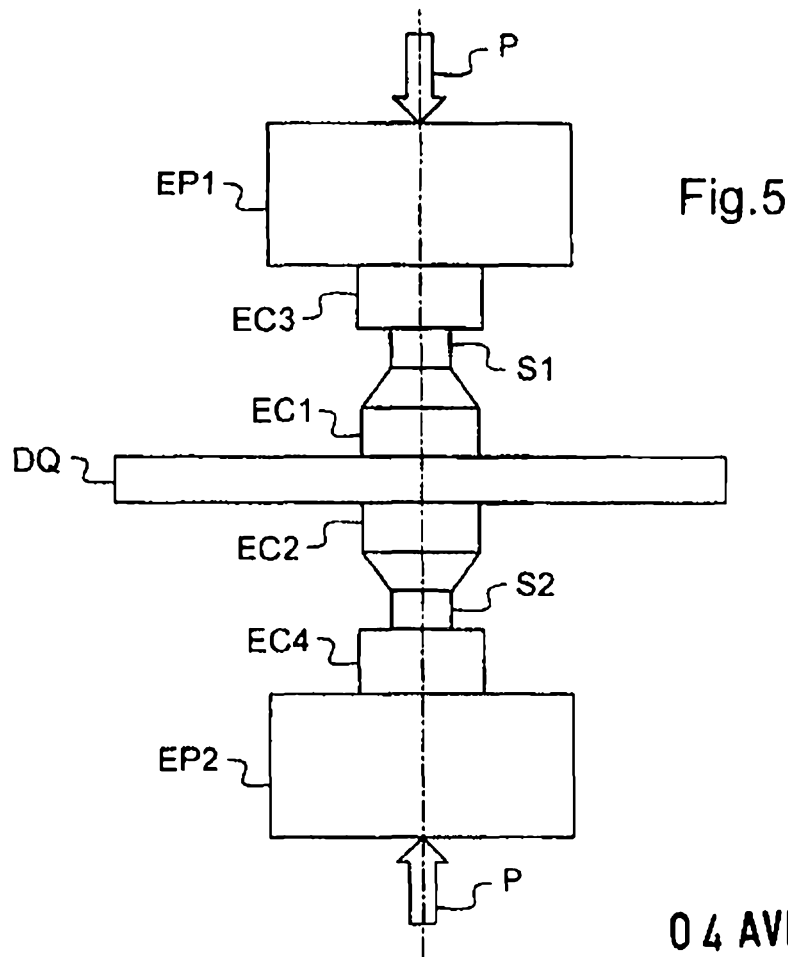
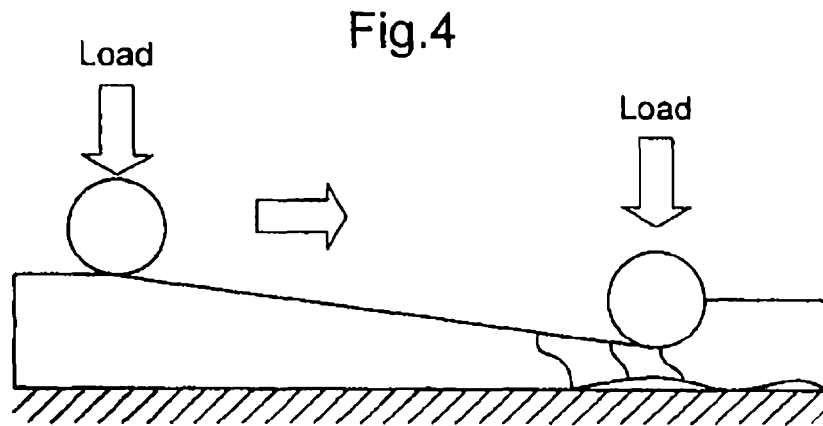

04 AVR. 2013
CABINET CAZENAVE sarl
Propriété Industrielle
B.P 500 YAOUNDE Cameroun
Tél. 22 21 32 89 - Fax 22 20 64 14
E-mail: cabinetcazenave@iccnel.cm

Fig.6

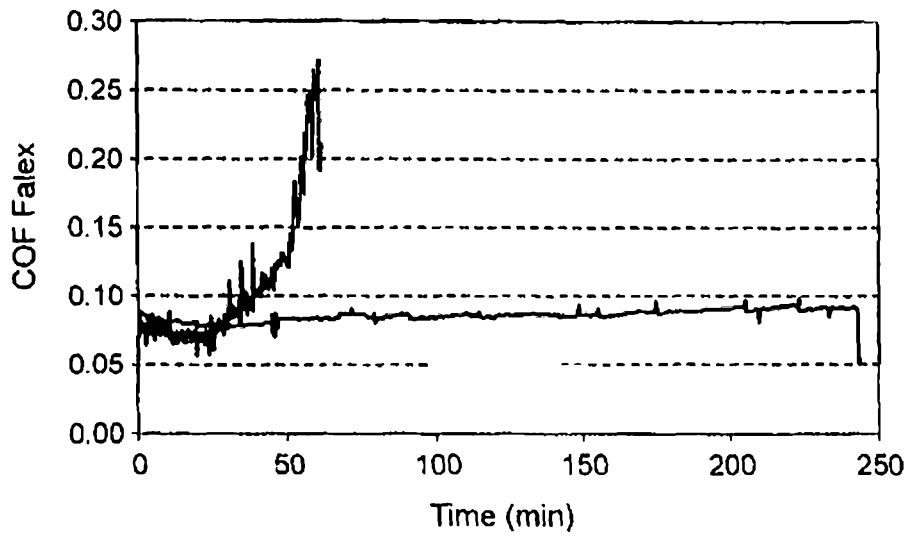
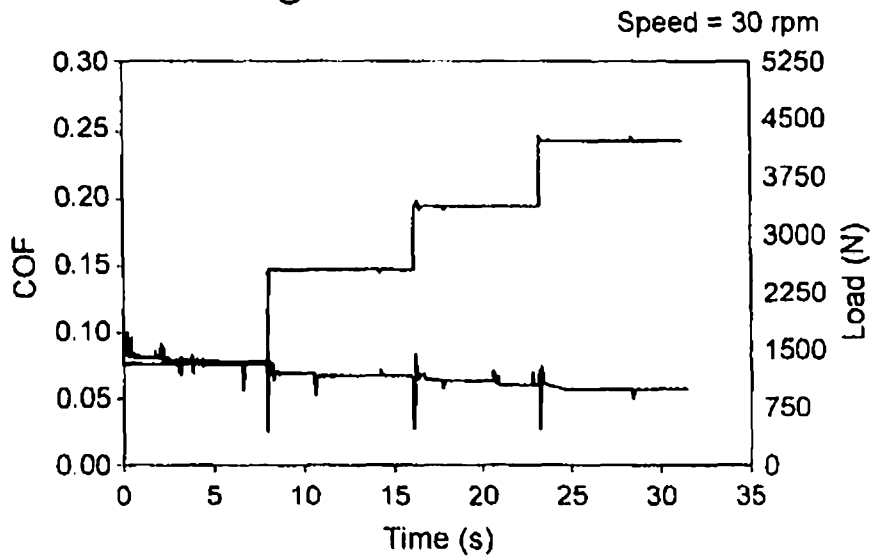

Fig.7



04 AVR. 2013

CABINET CAZENAVE sarl
Propriété Industrielle
B.P. 500 YAOUNDE Cameroun
Tél. 22 21 32 89 - Fax: 22 20 64 14
E-mail: cabinetcazenave@iccnnet.cm