

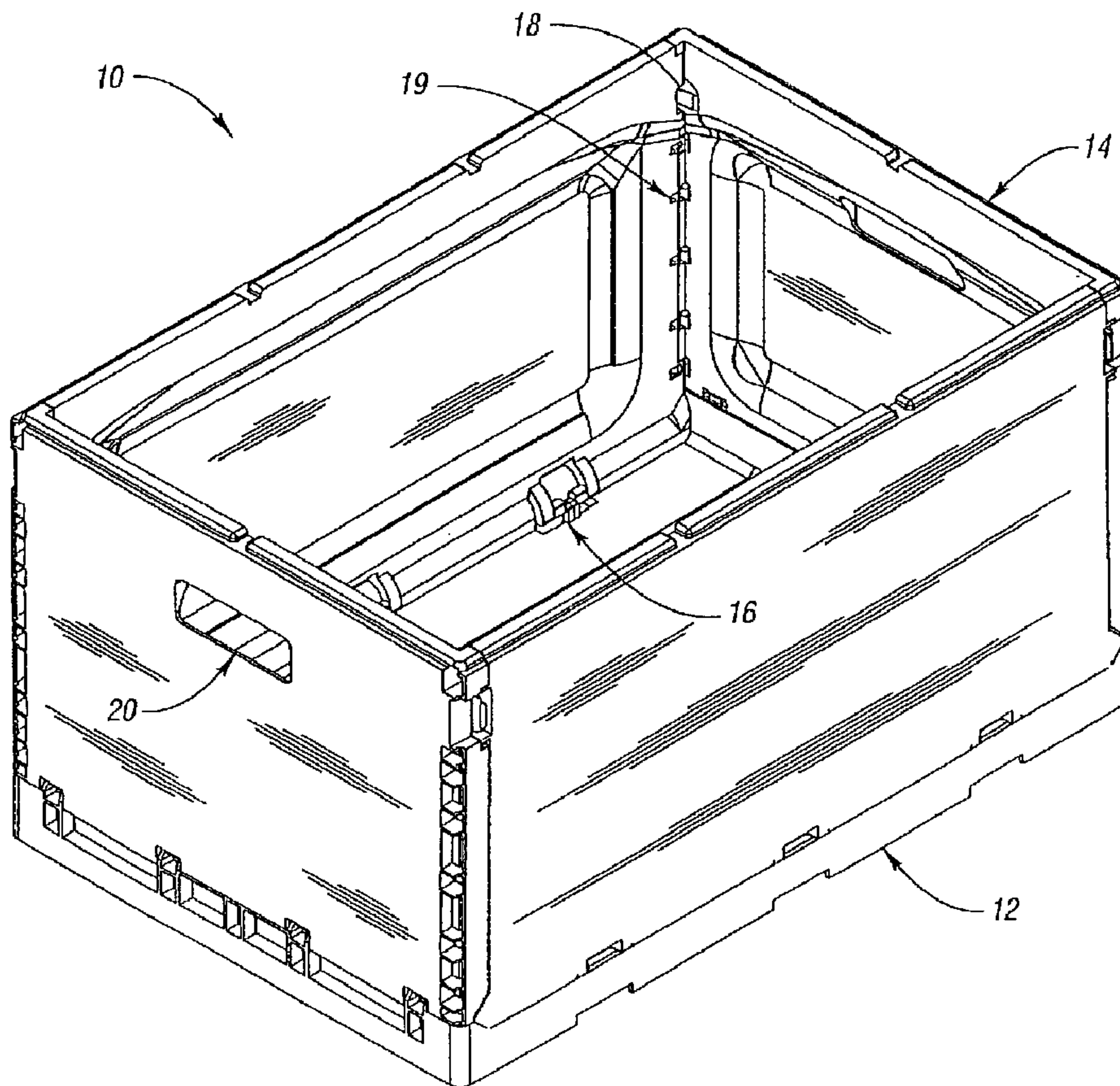

(86) Date de dépôt PCT/PCT Filing Date: 2002/08/19
 (87) Date publication PCT/PCT Publication Date: 2003/03/13
 (45) Date de délivrance/Issue Date: 2010/02/09
 (85) Entrée phase nationale/National Entry: 2004/02/25
 (86) N° demande PCT/PCT Application No.: US 2002/026336
 (87) N° publication PCT/PCT Publication No.: 2003/020602
 (30) Priorité/Priority: 2001/08/29 (US09/942,210)

(51) Cl.Int./Int.Cl. *B65D 6/18* (2006.01),
B65D 6/00 (2006.01), *B65D 6/12* (2006.01),
B65D 6/16 (2006.01)
 (72) Inventeurs/Inventors:
 SMYERS, JUSTIN M., US;
 OVERHOLT, TRENTON M., US
 (73) Propriétaire/Owner:
 REHRIG PACIFIC COMPANY, US
 (74) Agent: MACRAE & CO.

(54) Titre : CAISSE PLIABLE
 (54) Title: FOLDING CRATE



(57) Abrégé/Abstract:

A folding crate (10) or container is provided having a translating hinge arrangement (16) that allows a side wall (14) of the crate to freely translate in a vertical direction when rotated into a folded position. By allowing opposing side walls to move vertically relative to

(57) **Abrégé(suite)/Abstract(continued):**

a bottom component (12) of the crate when folded, subsequent overlapping side walls will lay substantially flat and parallel to the bottom component when folded thereon. This in turn allows the overall height of the crate to be reduced when in the folded position without requiring a specific side wall folding sequence.

(12) INTERNATIONAL APPLICATION PUBLISHED UNDER THE PATENT COOPERATION TREATY (PCT)

(19) World Intellectual Property Organization
International Bureau



(43) International Publication Date
13 March 2003 (13.03.2003)

PCT

(10) International Publication Number
WO 03/020602 A1

- (51) International Patent Classification⁷: **B65D 6/18**
- (21) International Application Number: PCT/US02/26336
- (22) International Filing Date: 19 August 2002 (19.08.2002)
- (25) Filing Language: English
- (26) Publication Language: English
- (30) Priority Data:
09/942,210 29 August 2001 (29.08.2001) US
- (71) Applicant (for all designated States except US): **REHRIG PACIFIC COMPANY** [US/US]; 4010 East 26th Street, Los Angeles, CA 90023 (US).
- (72) Inventors; and
(75) Inventors/Applicants (for US only): **SMYERS, Justin, M.** [US/US]; 607 N. Irena Ave., Apt. 202, Redondo Beach, CA 90277 (US). **OVERHOLT, Trenton, M.** [US/US]; 129 12th Street, Manhattan Beach, CA 90266 (US).
- (74) Agent: **DIAMOND, Konstantine, J.**; Rehrig Pacific Company, 4010 East 26th Street, Los Angeles, CA 90023 (US).
- (81) Designated States (*national*): AE, AG, AL, AM, AT, AU, AZ, BA, BB, BG, BR, BY, BZ, CA, CH, CN, CO, CR, CU, CZ, DE, DK, DM, DZ, EC, EE, ES, FI, GB, GD, GE, GH, GM, HR, HU, ID, IL, IN, IS, JP, KE, KG, KP, KR, KZ, LC, LK, LR, LS, LT, LU, LV, MA, MD, MG, MK, MN, MW, MX, MZ, NO, NZ, OM, PH, PL, PT, RO, RU, SD, SE, SG, SI, SK, SL, TJ, TM, TN, TR, TT, TZ, UA, UG, US, UZ, VN, YU, ZA, ZM, ZW.
- (84) Designated States (*regional*): ARIPO patent (GH, GM, KE, LS, MW, MZ, SD, SL, SZ, TZ, UG, ZM, ZW), Eurasian patent (AM, AZ, BY, KG, KZ, MD, RU, TJ, TM), European patent (AT, BE, BG, CH, CY, CZ, DE, DK, EE, ES, FI, FR, GB, GR, IE, IT, LU, MC, NL, PT, SE, SK, TR), OAPI patent (BF, BJ, CF, CG, CI, CM, GA, GN, GQ, GW, ML, MR, NE, SN, TD, TG).
- Published:
— with international search report

[Continued on next page]

(54) Title: FOLDING CRATE

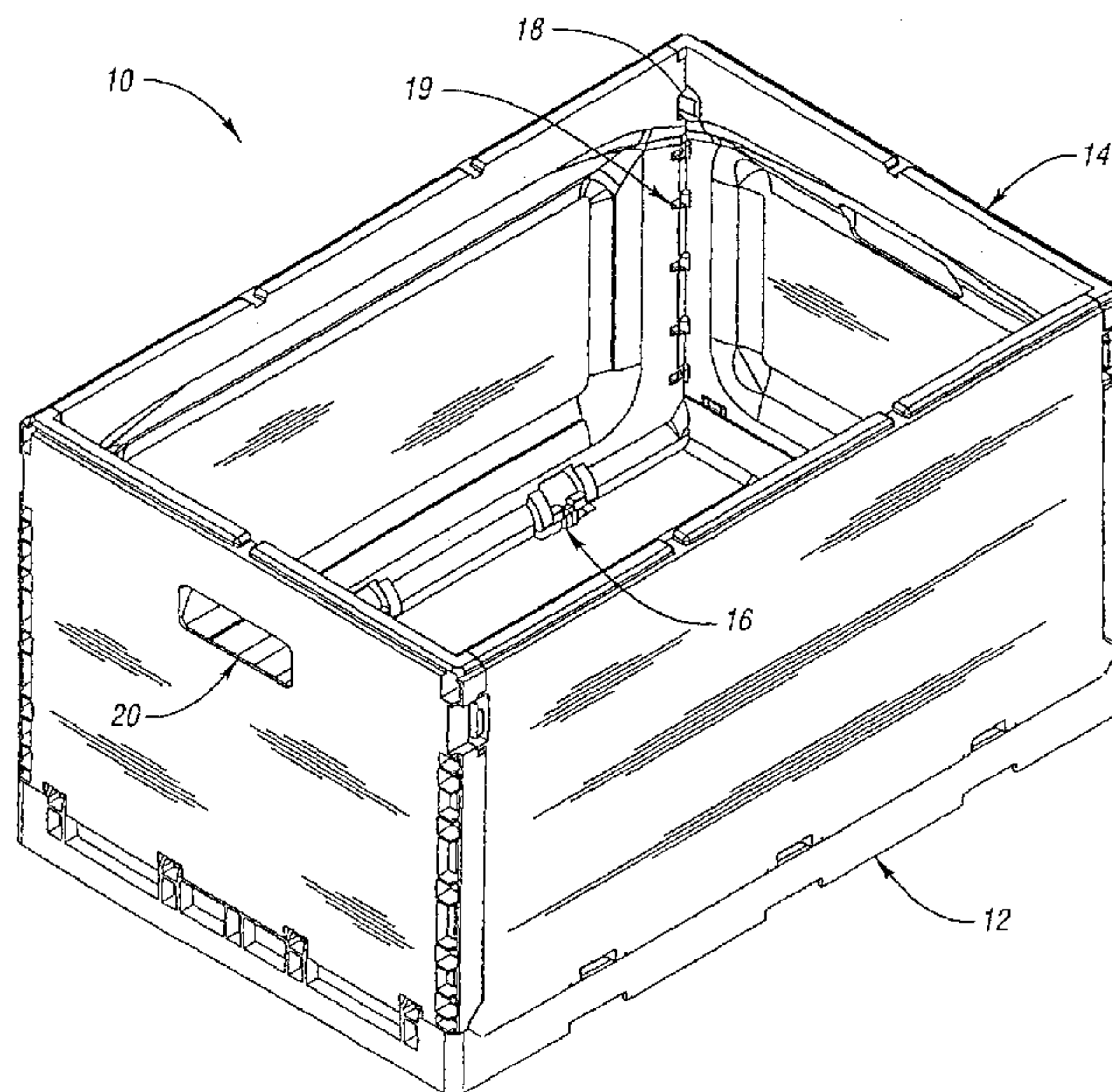

(57) Abstract: A folding crate (10) or container is provided having a translating hinge arrangement (16) that allows a side wall (14) of the crate to freely translate in a vertical direction when rotated into a folded position. By allowing opposing side walls to move vertically relative to a bottom component (12) of the crate when folded, subsequent overlapping side walls will lay substantially flat and parallel to the bottom component when folded thereon. This in turn allows the overall height of the crate to be reduced when in the folded position without requiring a specific side wall folding sequence.

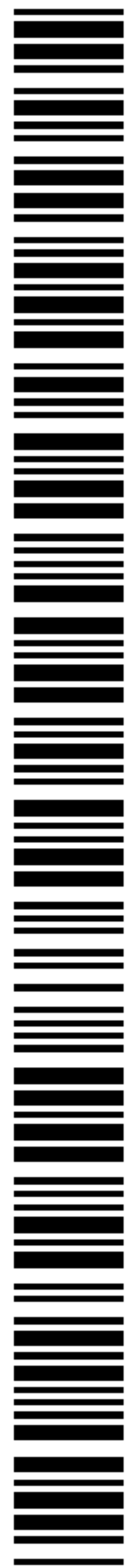

WO 03/020602 A1

WO 03/020602 A1



For two-letter codes and other abbreviations, refer to the "Guidance Notes on Codes and Abbreviations" appearing at the beginning of each regular issue of the PCT Gazette.

FOLDING CRATE

BACKGROUND OF THE INVENTION

Field of the Invention

5 The present invention relates to foldable crates suitable for holding and transporting objects.

Background Art

 Folding crates are generally known in the art. Typical folding crate arrangements connect each side wall to a bottom surface via a hinge arrangement.
10 When not in use, opposing side walls can be folded down onto the bottom surface to significantly reduce the space requirement of the crate.

 Depending on the overall size of the crate, it is common for two side walls to have a height greater than half the width of the bottom surface so that only one of the side walls will lie flat on the bottom surface, while the opposing side wall will
15 overlap and lie on top thereof. This causes the overlying side wall to be in a final nonparallel folded position relative to the bottom surface, i.e., an angle of incidence greater than zero. Thus, the overall height or "nest increment" of the folded crate is significantly increased by the angled, overlapping side wall when in the folded position.

20 One known approach for allowing the folded walls to lie parallel to the bottom surface, and thereby reduce the height of a folded crate, involves positioning the hinges of opposing side walls at different heights. However, such asymmetrical arrangements require the side walls to be folded in a specific sequence, which in turn increases complexity and convenience in handling the crate. In addition, the
25 asymmetrical hinge layout can present additional issues associated with tooling or molding of the crate. Another known approach involves forming the overlapping side walls with faces that align and intermesh when folded. Again, such an approach can increase the complexity in handling the crate, and may not even be practical for crates having side walls that overlap by a significant amount.

30 Therefore, a need exists for a folding crate having a reduced nest increment which does not require a specific side wall folding sequence, and can be employed with crates having side walls that substantially overlap.

SUMMARY OF THE INVENTION

Accordingly, one aspect of the present invention is to provide a folding crate having a hinge arrangement that allows a side wall to freely translate in a vertical direction upon folding so that the side wall will be generally parallel relative to a bottom component and a subsequently folded side wall and thereby substantially reduce the folded height of the crate without requiring a specific side wall folding sequence.

In accordance with this and other aspects, the present invention provides a folding crate including a side wall having a hinge pin, and a bottom component having a means for rotatably supporting the hinge pin to allow the side wall to be folded over the bottom component. The bottom component also includes a vertically extending slot formed therein. The hinge pin includes a portion thereof arranged to move within the slot when the side wall is in a folded position, thereby allowing the side wall to translate vertically into a position substantially parallel to the bottom component.

In accordance with another aspect of the present invention, a folding crate is provided including a side wall having a hinge pin, and a bottom component having a vertically extending slot formed therein, and a stationary hinge pin retainer arranged to support rotation of the hinge pin therein to allow the side wall to be folded over the bottom component. The hinge pin includes a portion thereof arranged to move within the slot upon the pin being rotated into a predetermined position relative to the bottom component so that the side wall can translate vertically into a position substantially parallel to the bottom component.

In accordance with still another aspect of the present invention, a folding crate is provided having a plurality of side walls each having a hinge arranged to allow the side wall to rotate and translate vertically, and a bottom component connected to each hinge. Because each hinge allows the side wall to translate vertically, any one of the side walls can be folded first so that the hinge will allow the wall to translate vertically. The hinge of a subsequently folded side wall will allow the side wall to fold over the previously folded side wall in a position substantially parallel relative thereto to reduce the overall folded height of the crate.

According to one aspect of the present invention there is provided a folding crate comprising a side wall having a hinge pin; and a bottom component having a means for rotatably supporting the hinge pin to allow the side wall to be folded over the bottom component, and a vertically extending slot formed therein, wherein the slot
5 extends downward and outward relative to a top surface of the bottom component, and wherein the hinge pin includes a portion thereof arranged to move within the slot when the side wall is in a folded position, thereby allowing the entire side wall to translate vertically into a position substantially parallel to the bottom component.

According to a further aspect of the present invention there is provided a
10 folding crate comprising a side wall; a bottom component; a hinge connection between the side wall and the bottom component including a hinge pin rotatably supported adjacent a vertically extending slot, the hinge pin including a cam portion with a major dimension larger than a width of the slot and a minor dimension less than the width of the slot; and a support adjacent the slot, the support including a
15 support surface adjacent an opening to the slot, wherein the cam portion is supported on the support surface when the side wall is in an unfolded position generally perpendicular to the bottom component, the support surface partially defining the opening to the slot.

According to another aspect of the present invention there is provided a
20 folding crate comprising a side wall; a bottom component; a hinge connection between the side wall and the bottom component including a hinge pin rotatably supported adjacent a vertically extending slot not perpendicular to the bottom component, the hinge pin including a cam portion with a major dimension larger than a width of the slot and a minor dimension less than the width of the slot, wherein the
25 slot is arcuate, such that the cam portion travels in an arcuate path in the slot when the cam portion is in the slot and the side wall is pivoted to a collapsed position; a support for supporting the hinge pin; and a stop member arranged to stop rotation of the side wall upon erecting the side wall into an unfolded position, the support comprising a stationary post member positioned relative to the stop member so as to form the slot
30 between the post member and the stop member.

The above aspects and other aspects, features, and advantages of the present invention are readily apparent from the following detailed description of the preferred embodiment(s) when taken in connection with the accompanying drawings.

5

BRIEF DESCRIPTION OF THE DRAWINGS

FIGURE 1 is an elevational perspective view of a crate in accordance with a first exemplary embodiment of the present invention;

10 FIGURE 2 is a partial elevational perspective view of the inside of the crate of FIGURE 1 showing a long wall and an end wall;

FIGURE 3 is an enlarged view of a portion of FIGURE 2 showing a full translating hinge arrangement and a center line section through another translating hinge arrangement;

15 FIGURE 4 is a side view cross-section showing the hinge arrangement in accordance with the first embodiment;

FIGURE 5 is a partial elevational perspective view of the outside of the crate of FIGURE 1;

FIGURE 6 is an elevational perspective cross-section of two long walls and an end wall when in the folded position;

20 FIGURE 7 is an end view of FIGURE 6 taken in the direction indicated by arrow A-A;

FIGURE 8 is a partial elevated perspective view of the inside of the crate in accordance with a second exemplary embodiment of the present invention;

25 FIGURE 9 is an enlarged view of a portion of FIGURE 7 showing a translating hinge arrangement in accordance with the second embodiment of the present invention;

FIGURE 10 is a side view cross-section showing the hinge arrangement in accordance with the second embodiment; and

30 FIGURE 11 is a partial elevational perspective view of the outside of the crate of FIGURE 8.

DETAILED DESCRIPTION OF THE PREFERRED EMBODIMENT(S)

Referring to Figures 1-5, a folding crate 10 is shown in accordance with a first, exemplary embodiment of the present invention. Crate 10 includes a bottom component 12 coupled to each of four side wall components 14 via a translating hinge arrangement 16 described more fully below. Thus, each side wall component 14 can be folded down inwardly across the bottom component 12 so as to be substantially parallel therewith. When erected, the side walls 14 form an enclosure with the bottom component 12. Adjacent side walls can be latched together in the erected position with any suitable latch or fastening mechanism arrangement. An interlocking arrangement 18 is shown for illustrative purposes, where one adjoining side wall includes a flexible latch arm integrally formed therewith which aligns with and engages a corresponding opening formed in the other adjoining side wall. However, such an arrangement is not to be construed as limiting. In addition, a set of vertically positioned guide elements 19 can be provided on each side wall to facilitate proper alignment of the side walls when raised.

The bottom component 12 and side wall components 14 of crate 10 can be injection molded from a thermoplastic material. In this exemplary embodiment, crate 10 is arranged in an open-top box configuration having a generally rectangular shape. However, the present invention can be applied to any type and shape of folding crate. Thus, the precise configuration shown in the Figures is not to be construed as limiting. As further shown, two or more side wall components 14 can include a handle or opening 20 formed therein. In addition, while not shown in the drawings, at least a portion of the bottom component and/or side walls can be formed having a pattern of holes or other openings for ventilation, weight reduction, etc.

Referring now more specifically to Figures 3 and 4, in accordance with this embodiment, hinge arrangement 16 includes a stationary member 22 having a curved hinge pin retainer 24 extending from at least a portion thereof, and a stop member 26 having a substantially parallel surface 28 and a curved surface 30. Both members 22 and 26 are integrally formed as part of bottom component 12. Stationary member 22 and stop member 26 are positioned relative to each other so as to form a vertically extending slot 32 defined by curved surface 30 and a partially

arcuate surface 34 on stationary member 22. In the embodiments shown, slot 32 extends downwardly and outward in an arcuate path.

Hinge arrangement 16 also includes a corresponding pivot arm 36 and stop heel 38 extending from the bottom edge of the side wall component 14. The pivot arm 36 includes a horizontally extending hinge pin 40 integrally formed therewith. Hinge pin 40 has a generally cylindrical shape arranged to fit within hinge pin retainer 24 and rotate therein to allow the side wall component to be folded downward over the bottom component 12.

Hinge pin 40 includes at least one selected portion thereof formed by substantially truncating or flattening the cylindrical circumference of pin 40. The selected portion or portions can be located at the end of the hinge pin 40. However, this is not to be construed as limiting. The flattened portion(s) form a cam-like member on the pin 40. More specifically, a non-flattened portion of the outer end surface of the hinge pin 40 supports pivoting within hinge pin retainer 24 as the side wall component is rotated up or down. The substantially flattened portion or portions of pin 40 are oriented relative to slot 32 so that rotation of the pin 40 aligns the flattened portion(s) with the top opening of slot 32 when the side wall component 14 has been folded into a substantially parallel position relative to the bottom component. When so positioned, the entire hinge pin 40 is able to freely slide within slot 32. As pin 40 slides down slot 32, the side wall component 14 is able to freely translate in a vertical direction, e.g., downward and outward, when folded so as to lay in a position substantially parallel to the bottom component 12. As seen in Figures 6 and 7, the translating hinge arrangement of the present invention allows a side wall component 14a to translate vertically by an amount sufficient to allow a subsequently folded side wall component 14b to lie substantially parallel when folded over the previously folded wall, thereby effectively reducing the overall height of the folded crate. In addition, because each side wall includes a translating hinge, opposing side walls do not need to be folded in a specific sequence relative to each other.

In addition, as the side wall component 14 is erected, a bottom surface of stop heel 38 will come to rest on flat surface 28 of stop member 26 to prevent any further upward rotation of the side wall component when the side wall is

substantially perpendicular to the bottom component 12 of the crate. This is accomplished by positioning flat surface 28 relative to hinge pin 40 so as to be in alignment with the center of rotation thereof. Heel 38 also provides structural support for the side wall to reduce potential load forces placed on hinge arrangement
5 16 when the crate has been unfolded.

Referring now to Figures 8-11, a second exemplary crate embodiment 100 is shown in accordance with the present invention having a translating hinge arrangement 102 used to allow the side wall component 14 to move vertically when rotated into the folded position. More specifically, as best seen in Figure 10, hinge
10 arrangement 102 includes an upwardly extending post member 104, a stationary member 106 having a curved hinge pin retainer 108 extending therefrom, and an arcuate stop member 110, all of which are integrally formed as part of bottom component 12. Appendage 104 and stop member 110 are positioned relative to each other so as to form the vertically extending slot 32 defined by the curved surface of
15 member 110 and a partially arcuate surface 112 on post member 104.

Hinge arrangement 102 also includes a corresponding pivot arm 114 extending from the bottom edge of the side wall component 14. Flattened end 42 of hinge pin 40 extends horizontally from pivot arm 114, and is arranged to fit within hinge pin retainer 108 and rotate therein to allow the side wall component 14 to be
20 folded downward over the bottom component 12.

As with crate 10, the flattened portion of pin end 42 allows the entire hinge pin 40 to slide down slot 32 when the side wall component is substantially parallel to the bottom component, i.e., when the flattened portion is aligned and oriented with the top opening of slot 32. As pin 40 slides down slot 32, the side wall
25 component 14 translates vertically into a position substantially parallel to the bottom component, thereby allowing a subsequently folded side wall to lie substantially parallel when folded down on top thereof.

In this embodiment, as the side wall component 14 is erected, a bottom surface of pivot arm 114 will come to rest on the outer curved surface of arcuate
30 stop member 108 to prevent any further upward rotation of the side wall component. The center point of the radius of stop member 108 is positioned relative to hinge pin 40 so as to be in alignment with the center of rotation thereof. In addition, the

distance between the center of rotation of pin 40 and the center point of stop 108 is equal to the thickest portion of the side wall component 14 so that pivot arm 114 will properly nest with stop member 108 when the side wall is the erect position.

5 While embodiments of the invention have been illustrated and described, it is not intended that these embodiments illustrate and describe all possible forms of the invention. Rather, the words used in the specification are words of description rather than limitation, and it is understood that various changes may be made without departing from the spirit and scope of the invention.

WHAT IS CLAIMED IS:

1. A folding crate comprising:
 - a side wall having a hinge pin; and
 - a bottom component having a means for rotatably supporting the hinge pin to allow the side wall to be folded over the bottom component, and a vertically extending slot formed therein, wherein the hinge pin includes a portion thereof arranged to move within the slot when the side wall is in a folded position, thereby allowing the entire side wall to translate vertically into a position substantially parallel to the bottom component and preventing the side wall from translating vertically when the side wall is in an unfolded position.
2. The folding crate of claim 1 wherein the portion of the hinge pin arranged to move within the slot is formed at an end of the hinge pin.
3. A folding crate comprising:
 - a side wall having a hinge pin; and
 - a bottom component having a means for rotatably supporting the hinge pin to allow the side wall to be folded over the bottom component, and a vertically extending slot formed therein, wherein the slot extends downward and outward relative to a top surface of the bottom component, and wherein the hinge pin includes a portion thereof arranged to move within the slot when the side wall is in a folded position, thereby allowing the entire side wall to translate vertically into a position substantially parallel to the bottom component.
4. The folding crate of claim 1 wherein the bottom component further includes a stop member arranged to stop rotation of the side wall upon erecting of the side wall into an unfolded position.
5. The folding crate of claim 4 wherein the side wall further comprises a stop heel formed thereon, said stop heel positioned on the side wall so as to contact a

surface of the stop member when the side wall is in substantially perpendicular to the bottom component.

6. The folding crate of claim 4 wherein the stop member comprises a curved surface having a center point in alignment with the center of rotation of the hinge pin.

7. The folding crate of claim 6 wherein the side wall further comprises a pivot arm formed thereon, said pivot arm positioned on the side wall so as to nest with the curved surface of the stop member when the side wall is substantially perpendicular to the bottom component.

8. The folding crate of claim 4 wherein the means for rotatably supporting the hinge pin comprises a stationary post member positioned relative to the stop member so as to form the slot between the post member and the stop member.

9. The folding crate of claim 1 wherein the hinge pin is integrally formed with the side wall.

10. The folding crate of claim 1 wherein the portion of the hinge pin arranged to move within the slot comprises at least one flattened portion in the hinge pin outer circumference so that the hinge pin is supported by the support means as the side wall component is erected perpendicular to the bottom component, and slides within the slot when the side wall component is substantially parallel to the bottom component.

11. A folding crate comprising:

a side wall having a hinge pin; and

a bottom component having a vertically extending slot formed therein, and a stationary hinge pin retainer arranged to support rotation of the hinge pin therein to allow the side wall to be folded over the bottom component, wherein the hinge pin includes a portion thereof arranged to move within the slot upon rotation of the pin into a predetermined position relative to the bottom component so that the side wall can translate vertically in a position substantially parallel to the bottom component

when folded, and wherein the portion of the hinge pin arranged to move within the slot is supported adjacent the slot when the side wall is perpendicular to the bottom component.

12. The folding crate of claim 11 wherein the portion of the hinge pin arranged to move within the slot is formed at an end of the hinge pin.

13. A folding crate comprising:

a side wall;

a hinge pin; and

a bottom component, one of the side wall and the bottom component having a vertically extending slot formed therein and a stationary hinge pin retainer arranged to support rotation of the hinge pin therein to allow the side wall to be folded over the bottom component, the slot extending downward and outward relative to a top surface of the bottom component when the side wall is in the unfolded position, and wherein the hinge pin includes a portion thereof arranged to move within the slot upon rotation of the pin into a predetermined position relative to the slot so that the side wall can translate vertically in a position substantially parallel to the bottom component when folded.

14. The folding crate of claim 11 wherein the bottom component further includes a stop member arranged to stop rotation of the side wall upon erecting of the side wall from a folded position.

15. The folding crate of claim 14 wherein the side wall further comprises a stop heel formed thereon, said stop heel positioned on the side wall so as to contact a surface of the stop member when the side wall is substantially perpendicular to the bottom component.

16. The folding crate of claim 14 wherein the stop member comprises a curved surface having a center point in alignment with the center of rotation of the hinge pin.

17. The folding crate of claim 16 wherein the side wall further comprises a pivot arm formed thereon, said pivot arm positioned on the side wall so as to nest with the curved surface of the stop member when the side wall is substantially perpendicular to the bottom component.

18. The folding crate of claim 14 wherein the bottom component further comprises a stationary post member positioned relative to the stop member so as to form the slot between the post member and the stop member.

19. The folding crate of claim 11 wherein the portion of the hinge pin arranged to move within the slot comprises at least one flattened portion in the hinge pin outer circumference so that the hinge pin is supported by the support means as the side wall component is erected perpendicular to the bottom component, and slides within the slot only when the side wall component is substantially parallel to the bottom component.

20. A folding crate comprising:

a plurality of side walls each having a hinge arranged to allow the side wall to rotate and translate vertically; and

a bottom component connected to each hinge, wherein any one of the side walls can be folded first so that the hinge will allow the wall to translate vertically so that a subsequently folded side wall will fold over the previously folded side wall in a position substantially parallel relative thereto to reduce the overall folded height of the crate, the hinge preventing the side wall from translating vertically when the side wall is substantially perpendicular to the bottom component.

21. The folding crate of claim 20 wherein each hinge comprises a hinge pin having a portion thereof arranged to move within a vertically extending slot formed in the bottom component.

22. The folding crate of claim 21 wherein the portion of each hinge pin arranged to move within a slot comprises at least one flattened portion in the hinge pin outer circumference arranged so that the hinge pin slides within a slot.

23. The folding crate of claim 21 wherein the portion of the hinge pin arranged to move within the slot is formed at an end of the hinge pin.

24. The folding crate of claim 20 wherein the bottom component further includes a stop member arranged to stop rotation of each side wall upon erecting into an unfolded position.

25. The folding crate of claim 24 wherein each side wall further comprises a stop heel formed thereon, said stop heel positioned on each side wall so as to contact a surface of the stop member upon rotation of a side wall into a position substantially perpendicular to the bottom component.

26. A folding crate comprising:

a side wall;

a bottom component;

a hinge connection between the side wall and the bottom component including a hinge pin rotatably supported adjacent a vertically extending slot, the hinge pin including a cam portion with a major dimension larger than a width of the slot and a minor dimension less than the width of the slot; and

a support adjacent the slot, the support including a support surface adjacent an opening to the slot, wherein the cam portion is supported on the support surface when the side wall is in an unfolded position generally perpendicular to the bottom component, the support surface partially defining the opening to the slot.

27. The folding crate of claim 26 wherein the support surface is concave.

28. The folding crate of claim 27 wherein the cam portion of the hinge pin comprises at least one flattened portion in an outer circumference of the hinge pin so

that the hinge pin is supported by the support as the side wall is erected perpendicular to the bottom component, and is slidable to a position within the slot at which the side wall is parallel to the bottom component.

29. The folding crate of claim 26 wherein the cam portion of the hinge pin is formed at an end of the hinge pin.

30. The folding crate of claim 26 further including a stop member arranged to stop rotation of the side wall upon erecting the side wall into an unfolded position.

31. The folding crate of claim 30 wherein the side wall further comprises a stop heel formed thereon, said stop heel positioned on the side wall so as to contact a surface of the stop member when the side wall is substantially perpendicular to the bottom component.

32. The folding crate of claim 26 wherein the hinge pin is integrally formed with the side wall.

33. The folding crate of claim 26 wherein the cam portion is positioned in the slot when the side wall is in a fully collapsed position when the side wall is resting directly on one of the bottom component and another collapsed side wall.

34. The folding crate of claim 26 wherein the cam portion is positioned in the slot when the side wall is in a fully collapsed position.

35. A folding crate comprising:

a side wall;

a bottom component;

a hinge connection between the side wall and the bottom component including a hinge pin rotatably supported adjacent a vertically extending slot not perpendicular to the bottom component, the hinge pin including a cam portion with a major dimension larger than a width of the slot and a minor dimension less than the width of

the slot, wherein the slot is arcuate, such that the cam portion travels in an arcuate path in the slot when the cam portion is in the slot and the side wall is pivoted to a collapsed position;

a support for supporting the hinge pin; and

a stop member arranged to stop rotation of the side wall upon erecting the side wall into an unfolded position, the support comprising a stationary post member positioned relative to the stop member so as to form the slot between the post member and the stop member.

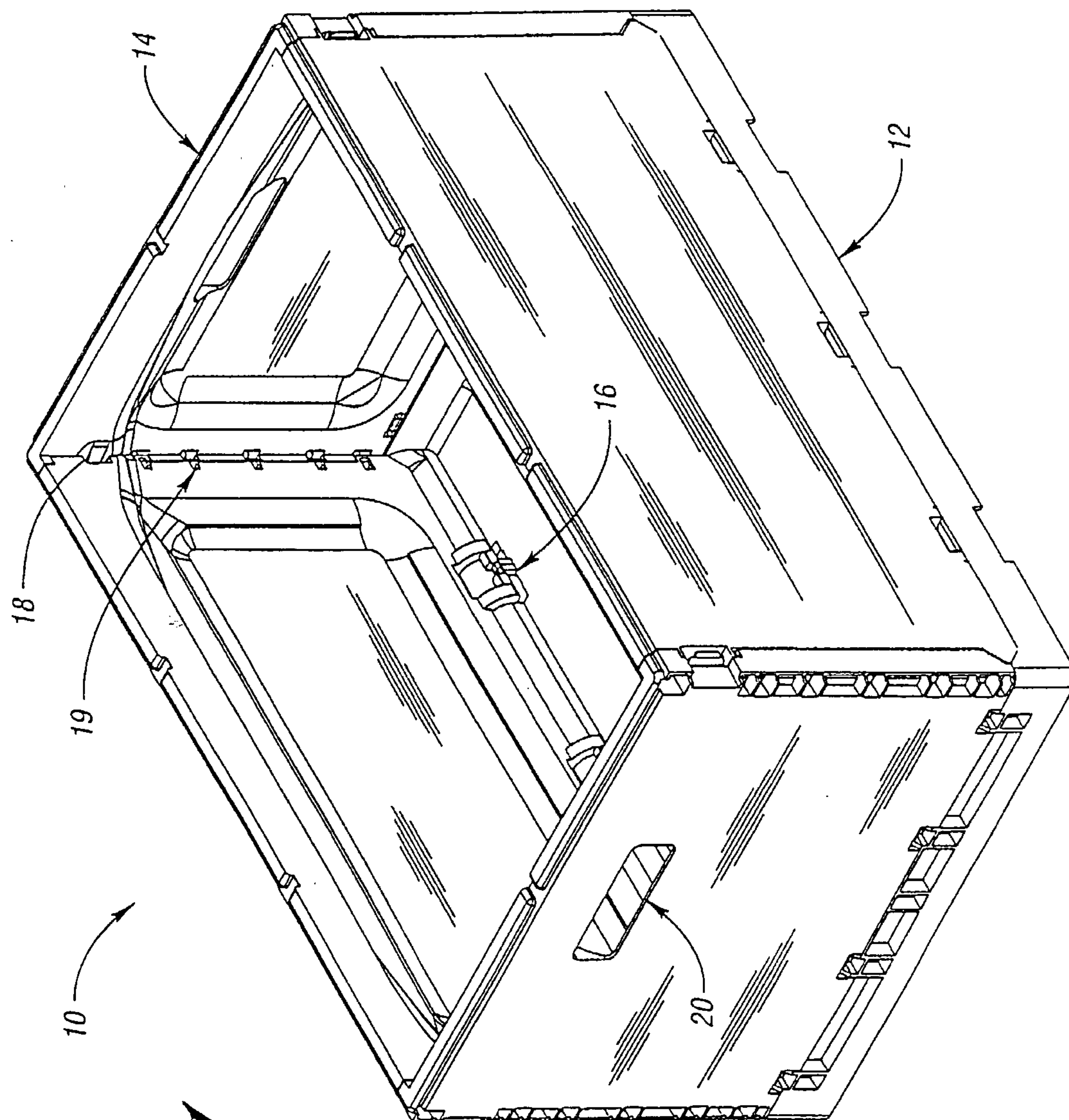

Fig. 1

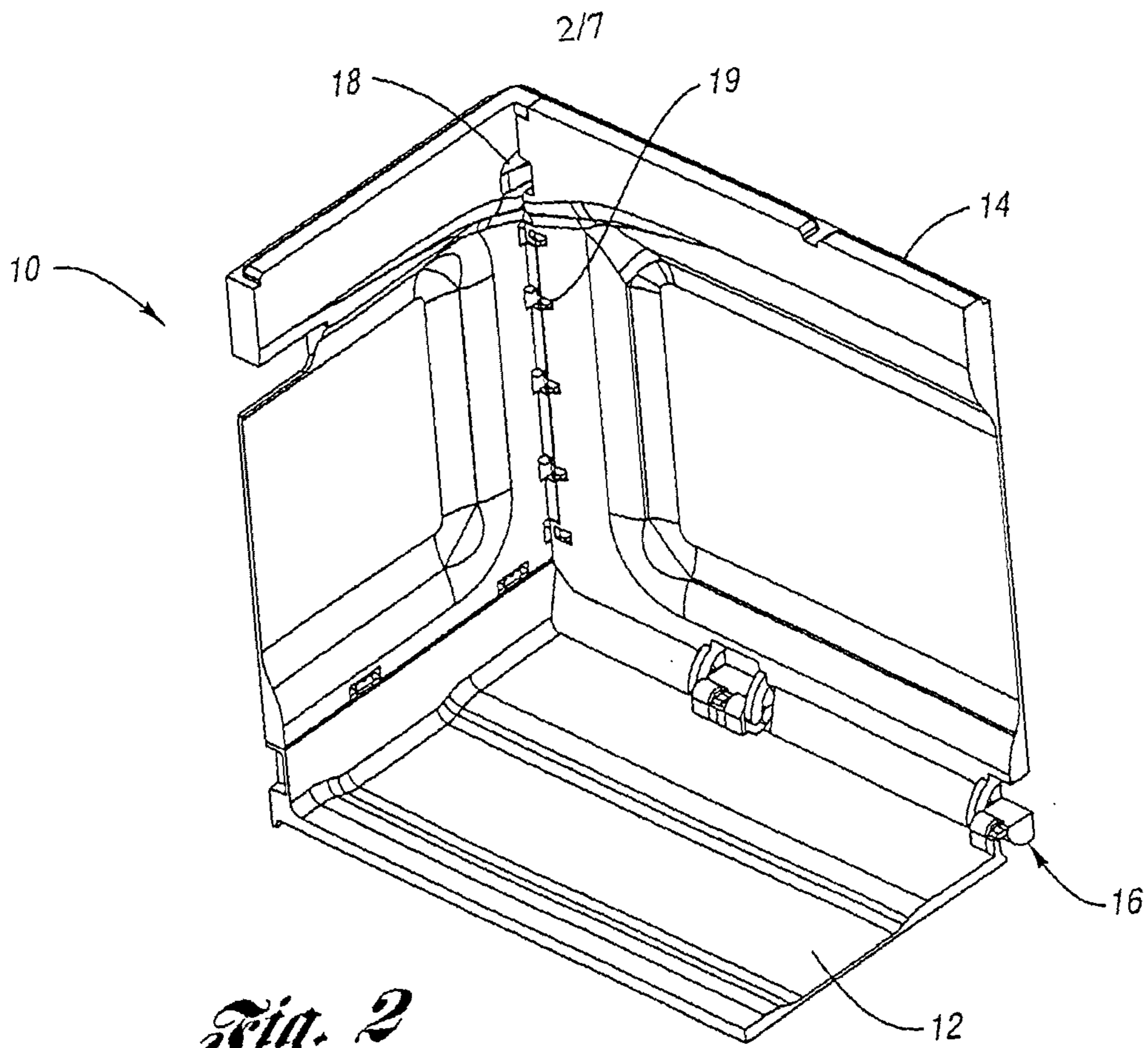

Fig. 2

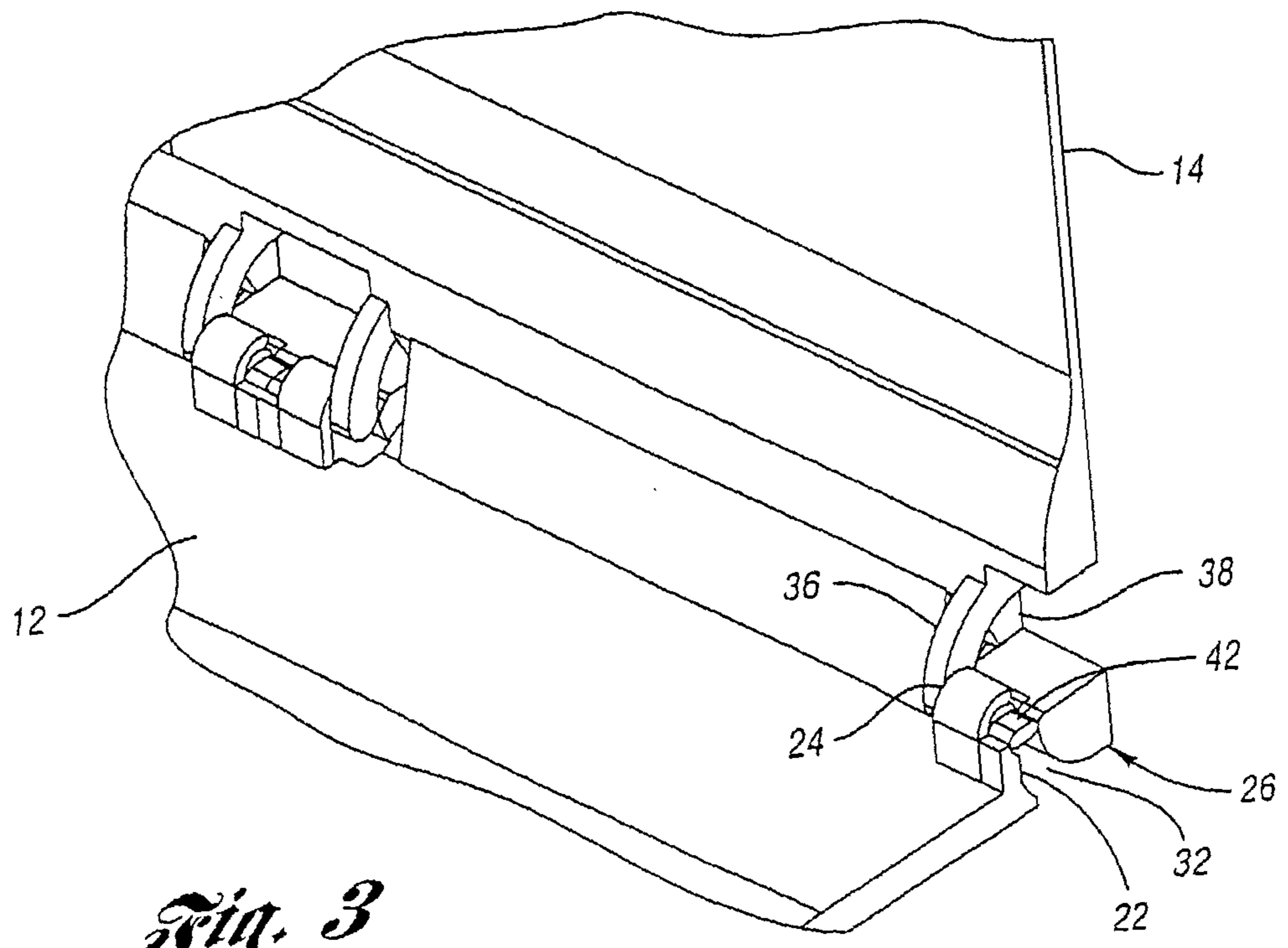
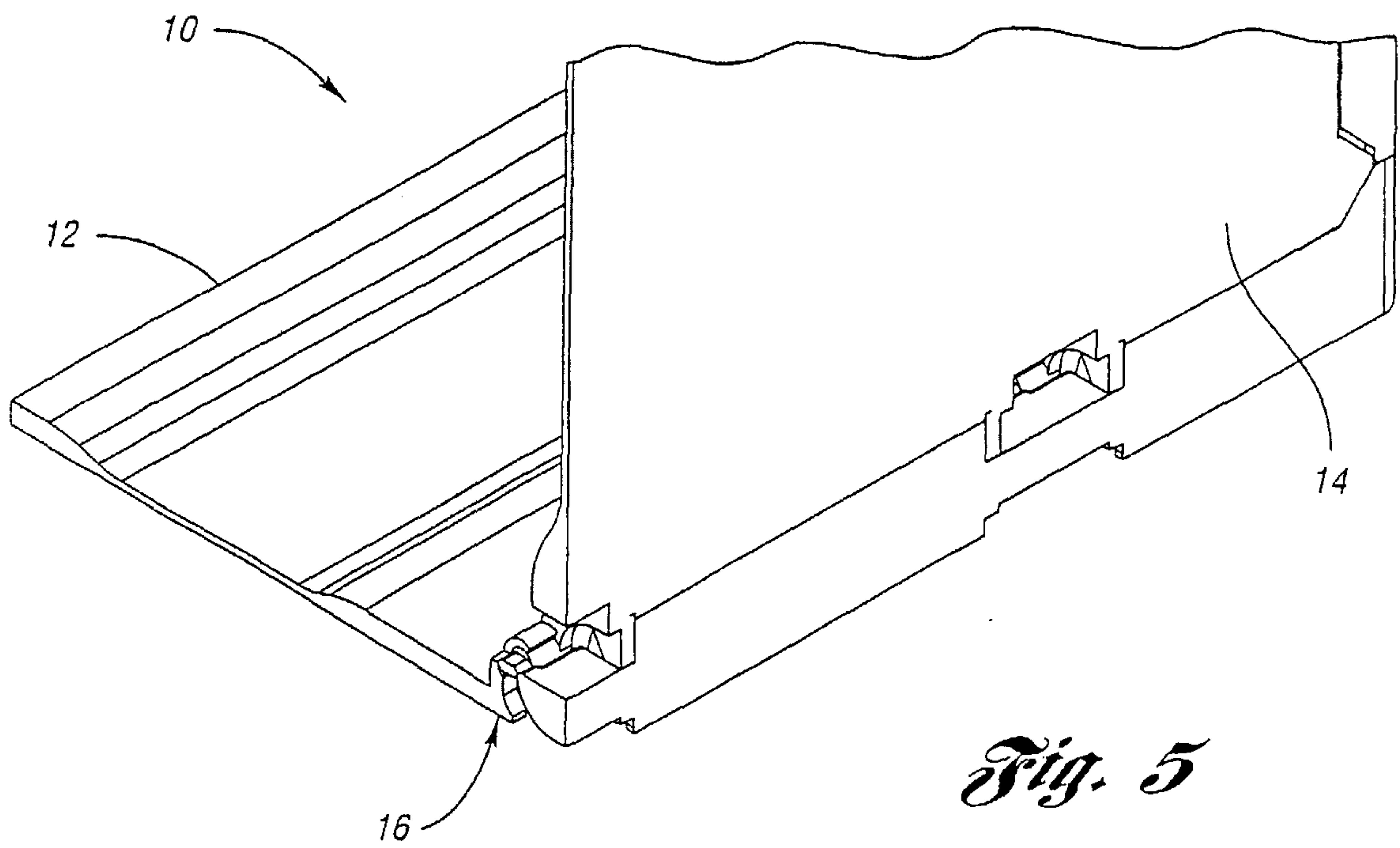
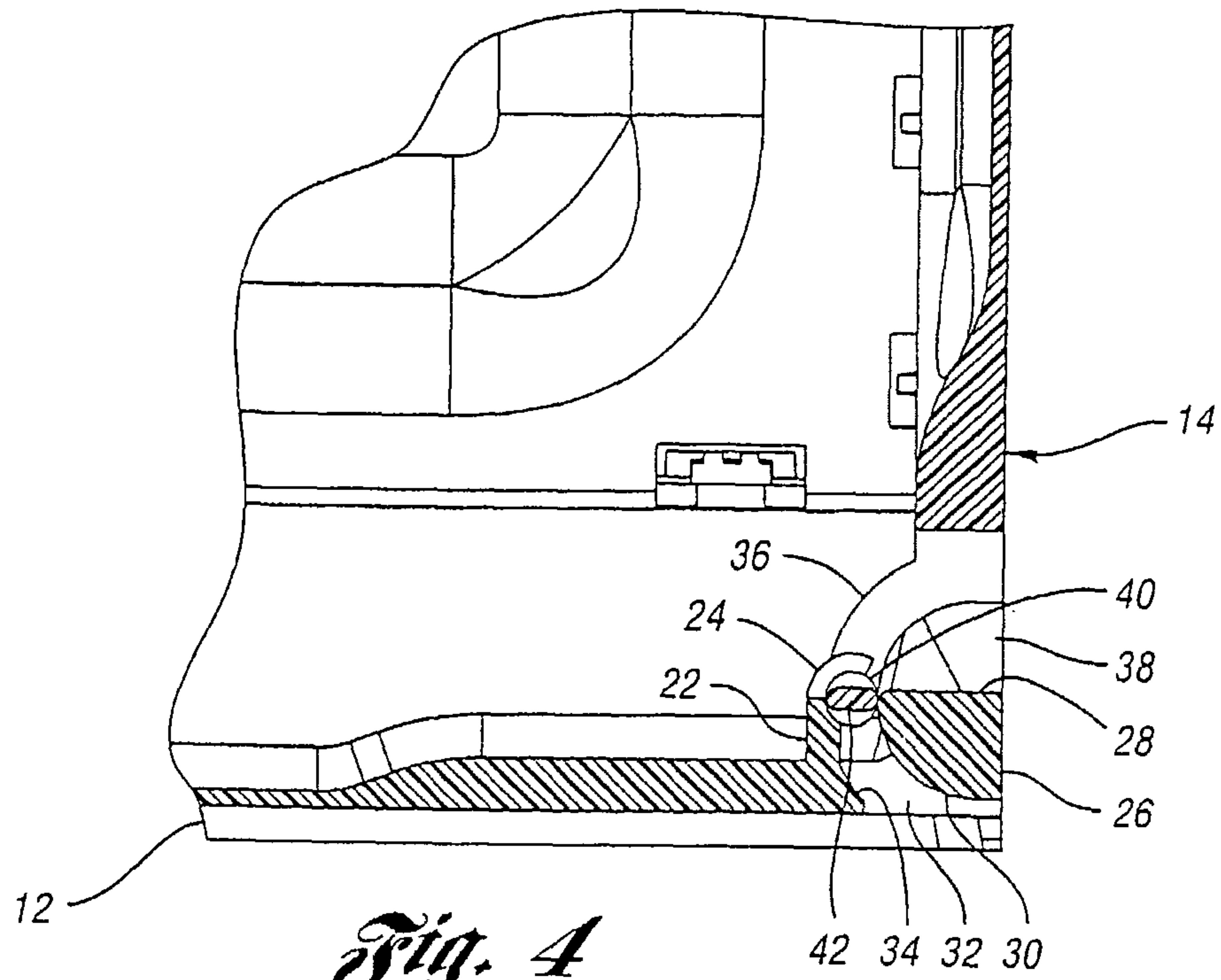
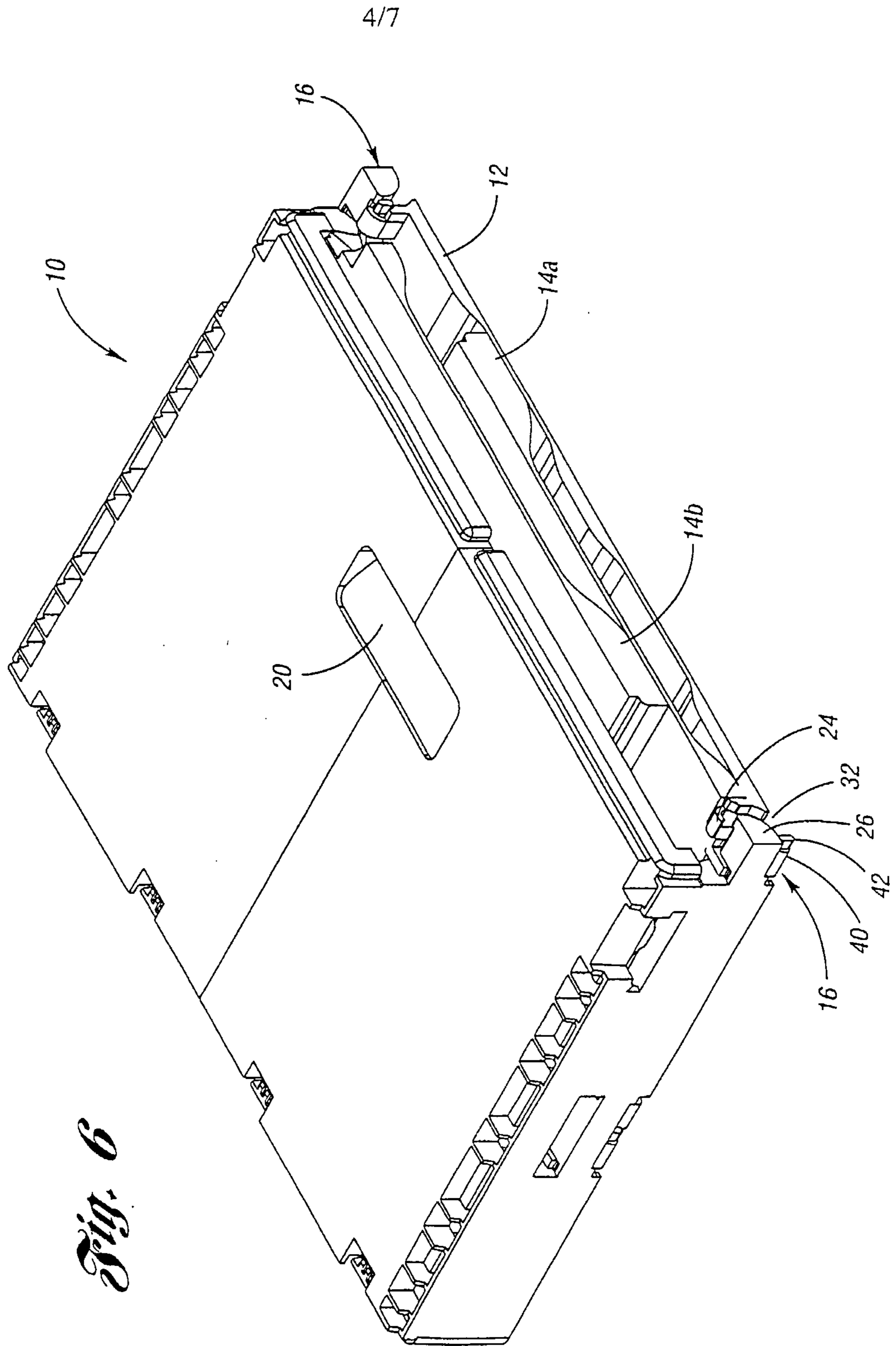

Fig. 3

3/7





5/7

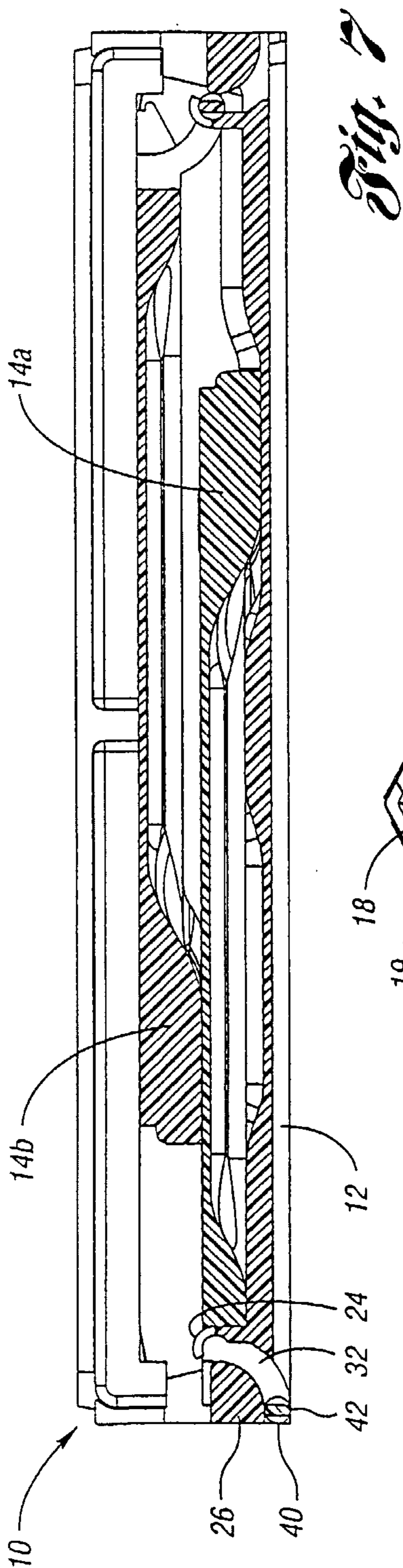

Fig. 7

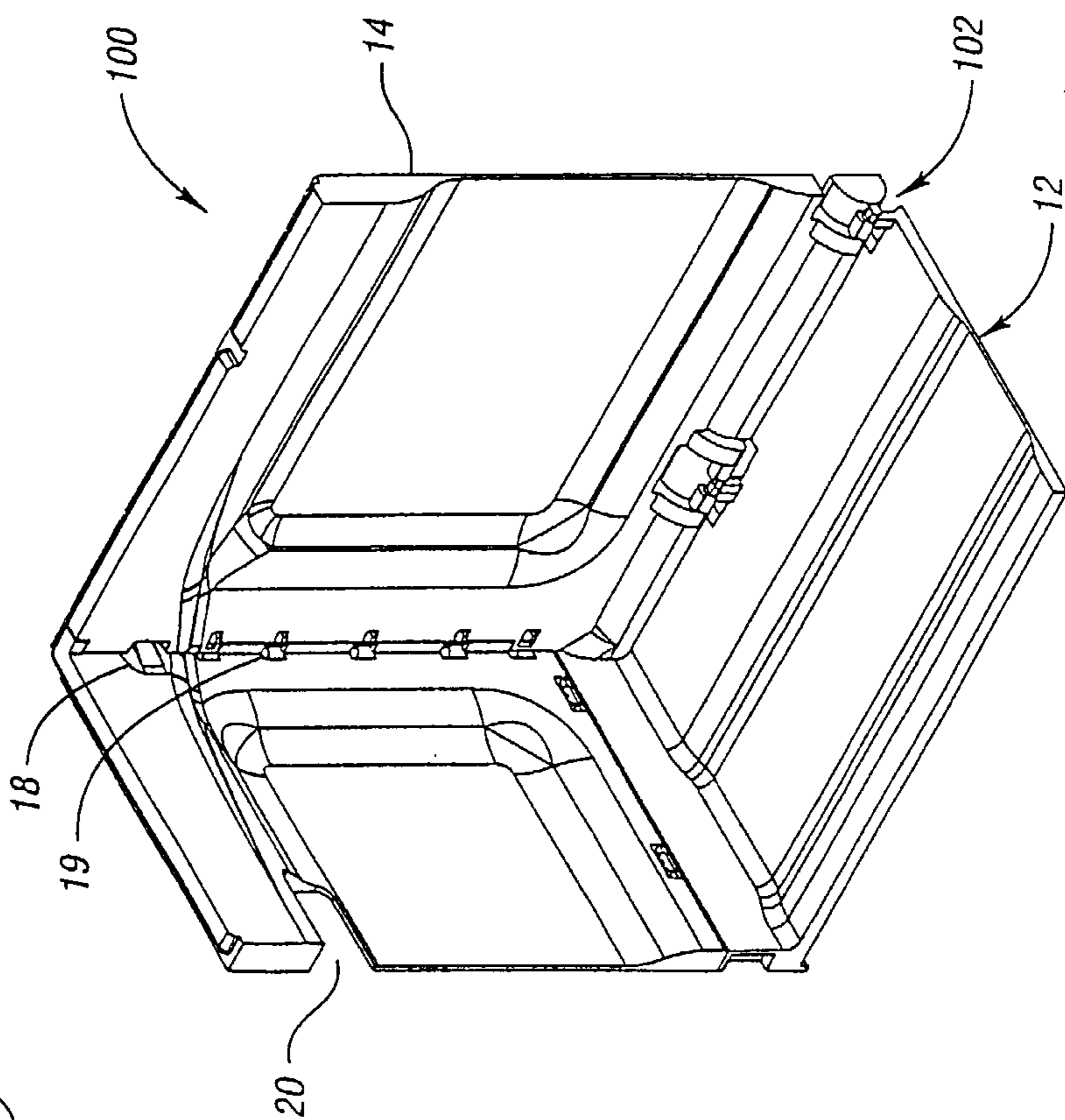
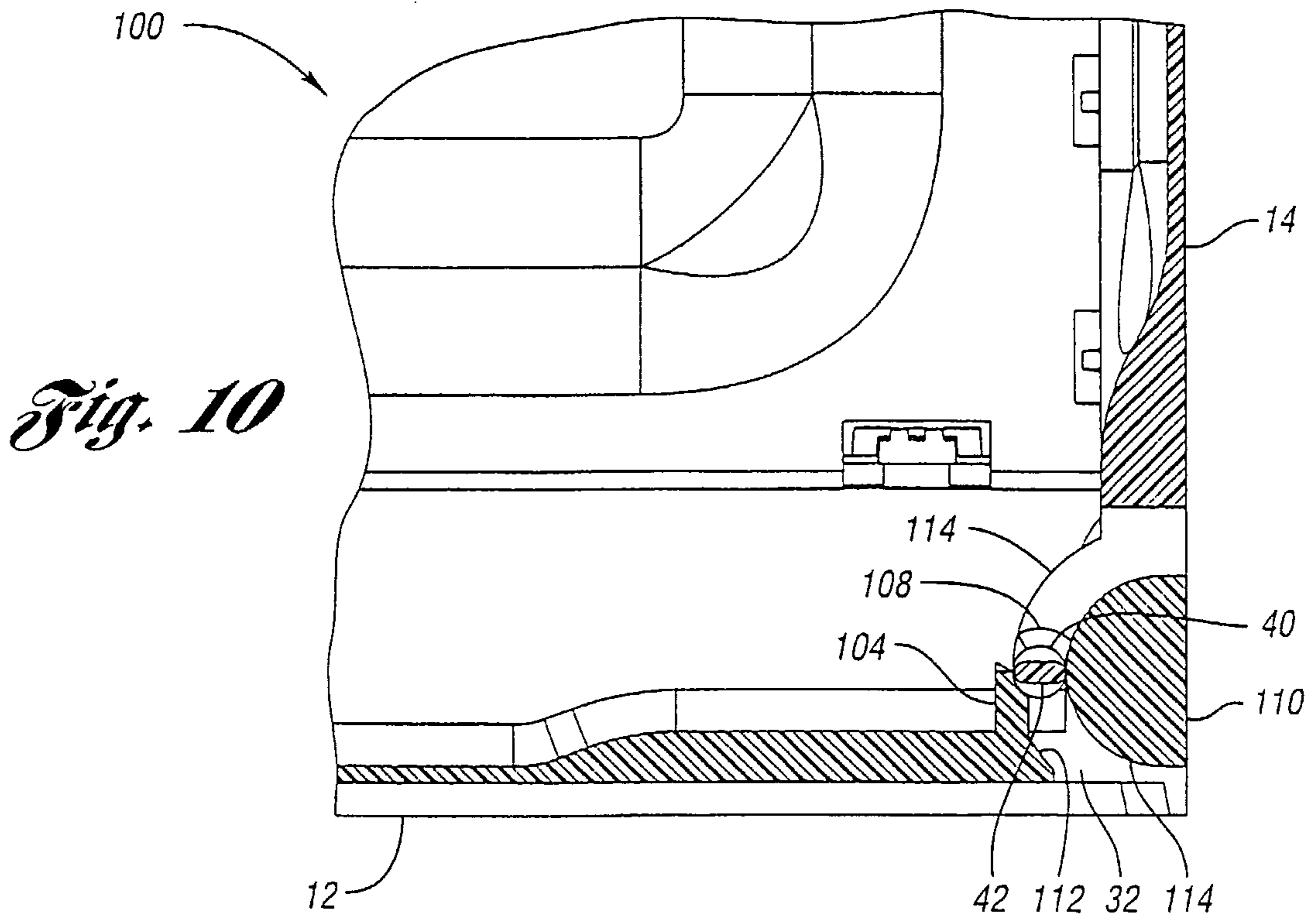
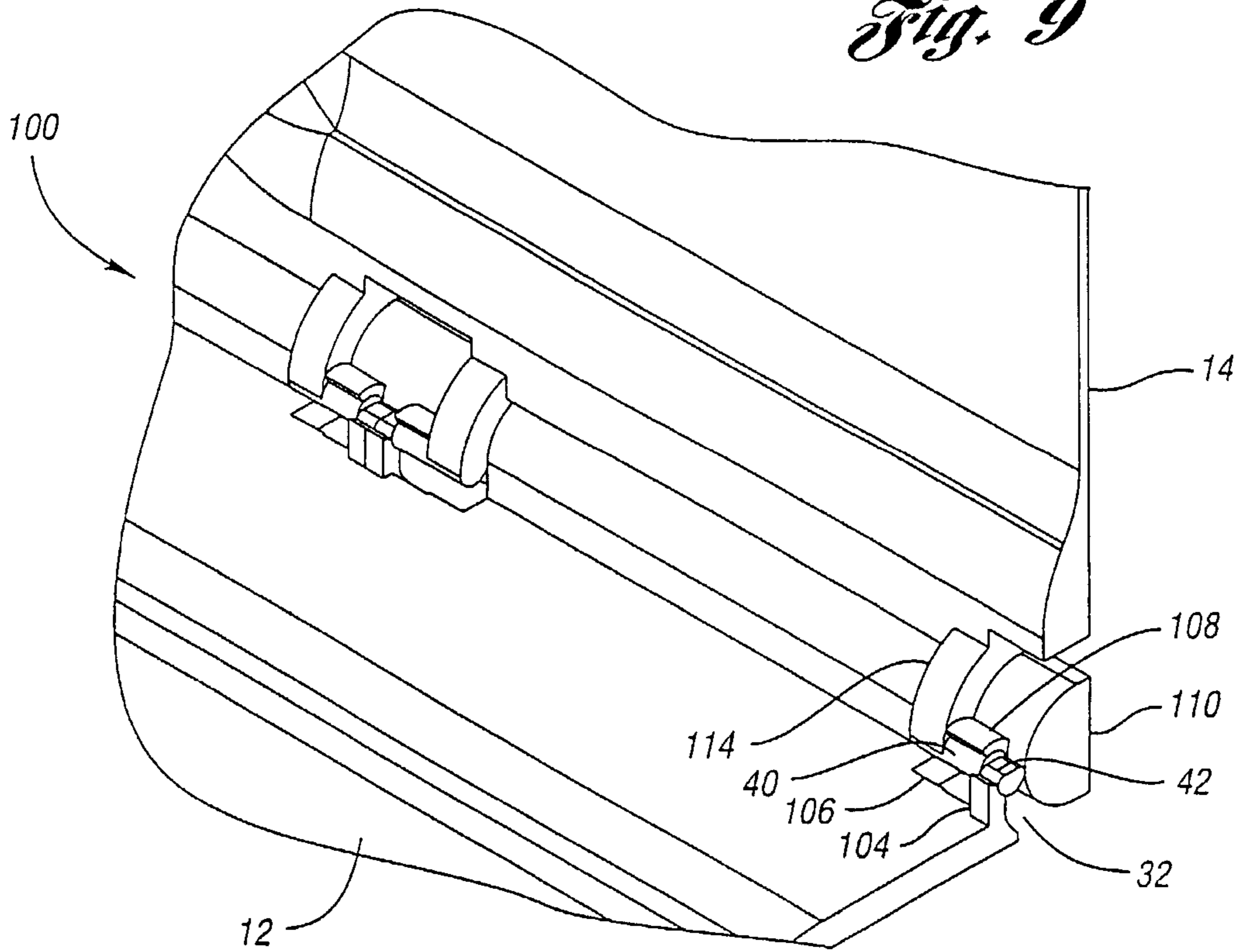

Fig. 8

6/7

Fig. 9



7/7

