

N. P. SHELDON.
PUMP.

No. 110,936.

Patented Jan. 10, 1871.

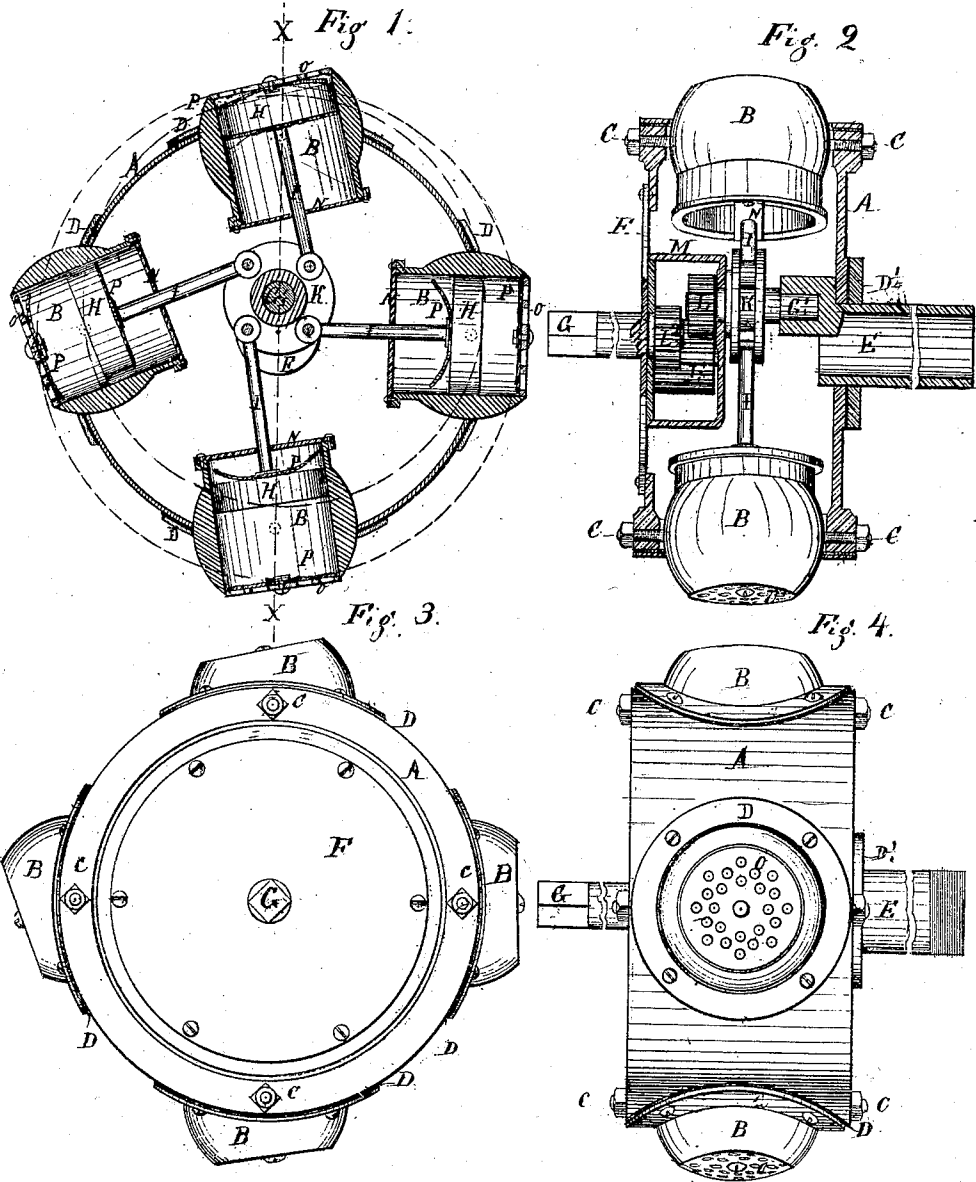

Witnesses
W. H. Whistler
Walter Glass

INVENTOR.

Nathaniel P. Sheldon

United States Patent Office.

NATHANIEL P. SHELDON, OF SAN FRANCISCO, ASSIGNOR TO HIMSELF AND WM. H. HALL, OF SAN JOSÉ, CALIFORNIA

Letters Patent No. 110,936, dated January 10, 1871.

IMPROVEMENT IN PUMPS.

The Schedule referred to in these Letters Patent and making part of the same.

I, NATHANIEL P. SHELDON, of the city and county of San Francisco, and State of California, have invented certain Improvements in the Mode of Constructing Pumps, of which the following is a specification.

Nature and Objects of the Invention.

The first part of my invention relates to the combination of a series of cylinders, of any required number, with a frame or shell in which they are hung upon axles, in such a manner that they may revolve together around a common center.

The second part of my invention relates to the combination of a series of plungers, corresponding in number to the number of cylinders used with a device, hereinafter described as a plunger-wheel, in such a manner that the plungers may revolve with the cylinders.

The third part of my invention relates to the combination of the plunger-wheel with a shaft, set eccentric to or upon one side of the driving-shaft, in such a manner as to hold the center of motion in the plungers to a different center from that of the cylinders.

The fourth part of my invention relates to the combination of the plunger-wheel with the frame or driving-shaft by means of gears or other device, in such a manner that any motion communicated to one shall cause the other to move in the same direction, and compel both to make their revolution in the same space of time.

Description of the Accompanying Drawing.

Figure 1 is a vertical transverse section of a machine embodying my invention, showing the positions of the cylinders, plungers, and valves when in operation.

Figure 2 shows the working parts of the machine, and the manner in which the plungers and cylinders are made to revolve together by gear-wheels.

Figure 3 is a side elevation.

Figure 4 is an end elevation.

General Description.

A is a metal frame or shell with circular openings in its circumference corresponding in number and size to the cylinders B, which are hung therein upon the axles C, secured to the frame.

D is a gland, for securing packing around the cylinders.

In the center of the frame A, upon one side, is an opening surrounded by a stuffing-box, or other device, for packing around the bearing upon the discharge-pipe E, around which the frame revolves. Upon the opposite side this frame has a large opening, covered by the flange F, attached to the driving-shaft G. The cylinders B are short metal cylinders, with their out-

er ends, which oscillate upon the axles C, turned to a section of a globe, of which the axles represent the center.

The plungers H have ports, covered by a valve.

The plunger-rods I are attached to the plunger by a rigid attachment, and to the plunger-wheel K by a loose attachment or joint.

The plunger-wheel K has the gear-wheel L cast upon or rigidly attached to it. This gear meshes into the intermediate gear-wheels L¹, which meshes into the gear-wheel L², rigidly attached to the flange F, upon line with the driving-shaft G.

The gear-wheels L and L² should be of like diameter and number of cogs, thus compelling them, with the instruments to which they are attached through the agency of the intermediate gear-wheel L¹, to make their respective revolutions in the same space of time.

G' is a stationary shaft, set firmly into the discharge-pipe E. This shaft forms a bearing for the plunger-wheel R, which revolves around it.

M is a collar or box, inclosing the gears, and is held in position by bearings upon the shafts G and G'; it also forms a bearing for the shaft upon which the intermediate gear L¹ revolves.

The guides N upon the inner ends of the cylinders through which the plunger-rods pass, are for the purpose of keeping the cylinders upon a line with the plungers.

The valve-seats O should be so inserted in the cylinders by screws, or other device, that they may be easily removed, and the plungers similarly attached to their rods, thus giving easy access to all the valves without taking the pump apart.

D' is a gland for the packing between the frame and discharge-pipe.

The foregoing description represents the application of my invention as a submerged pump; but I contemplate and propose applying it in a "suction and force" pump in the following-described ways; to wit:

First, by inclosing the pump constructed and arranged as herein described in an outer shell or case, with a suction-pipe inserted therein.

Second, by placing the valves with the pump thus inclosed upon the outside of their valve-seats, thus causing them to open by pressure from without, and close by pressure from within, change the discharge-pipe E to a suction pipe, and discharge through the pipe in the outer shell.

The revolution of the plungers and cylinders around their respective centers in the same space of time may be controlled by attaching the plunger-wheel K firmly to the shaft G', extending said shaft through the pipe E, placing the gear-wheels L and L¹ upon the outside of shafts G and G', outside of the

pump, and meshing them into two gear-wheels attached to a parallel shaft, or a stiff rod may be firmly set in the plunger-wheel, and play through an oscillating bearing attached to the frame A.

I do not wish to be confined to any particular mode of producing the required uniformity of motion.

In the operation of my invention when in motion, the plungers and cylinders each describe a circle in their revolutions, as seen by the circular dotted lines in fig. 1; but, owing to the different positions of their respective centers, any given point in the circle described by the cylinders gradually approaches the circle described by the plungers during one-half of a revolution, and passes away from them during the other half, thus passing each cylinder back and forth over its plunger to the extent of the length of the stroke once during every revolution, thereby causing them to be filled and discharged.

The line X X drawn across the fig. 1 cuts the points between the suction and discharge.

While the outer end of the cylinder is passing away from the plunger the valve upon the plunger remains closed by the pressure from within, and the water before it is held in place, and the movement of the cylinder forces the discharge; at the same time receiving water from the outside port with the open valve.

When the reverse motion takes place the valve up-

on the port in the plunger opens, closing the outer port by pressure upon the valve from within, and the water passes through the plunger-port.

The pressure of the discharging column of water upon the plunger when its port is closed is communicated through its rod to the plunger-wheel, and acting upon said wheel at an angle, as seen in fig. 1, and thence through the gears upon the frame, operates as a power to force or revolve the pump in the required direction, thus making the discharging column of water a lever to itself.

I claim as my invention—

1. The combination of the cylinders B with the revolving frame A, substantially as and for the purpose hereinbefore set forth.

2. The combination with the plunger H and the plunger-wheel K, placed eccentrically to the revolving cylinder A, substantially as and for the purpose hereinbefore set forth.

3. The combination of the plunger-wheel K with the frame A and gear L, intermediate gear L', and gear L², substantially as and for the purpose set forth.

NATHANIEL P. SHELDON.

Witnesses:

W. H. WASTE,
WALTER GLASS.