

(No Model.)

3 Sheets—Sheet 1.

M. BUTLER.
DENTAL CHAIR.

No. 490,637.

Patented Jan. 31, 1893.

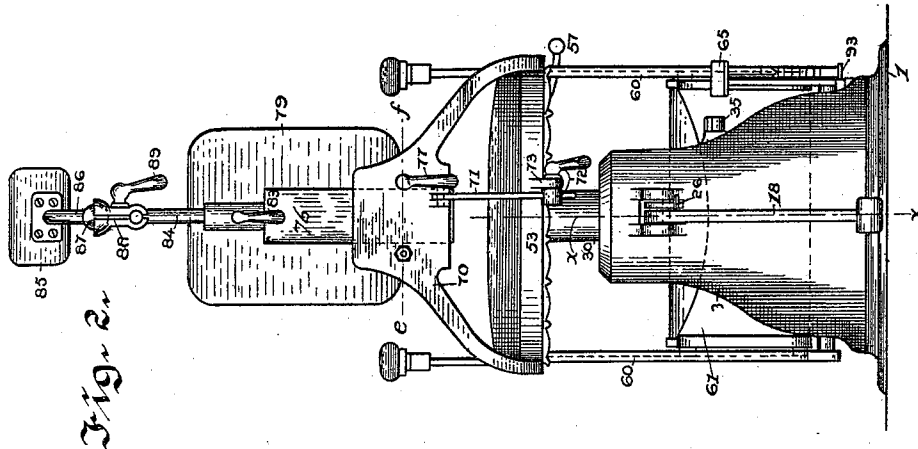

Fig. 2.

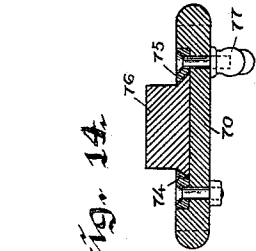

Fig. 14.

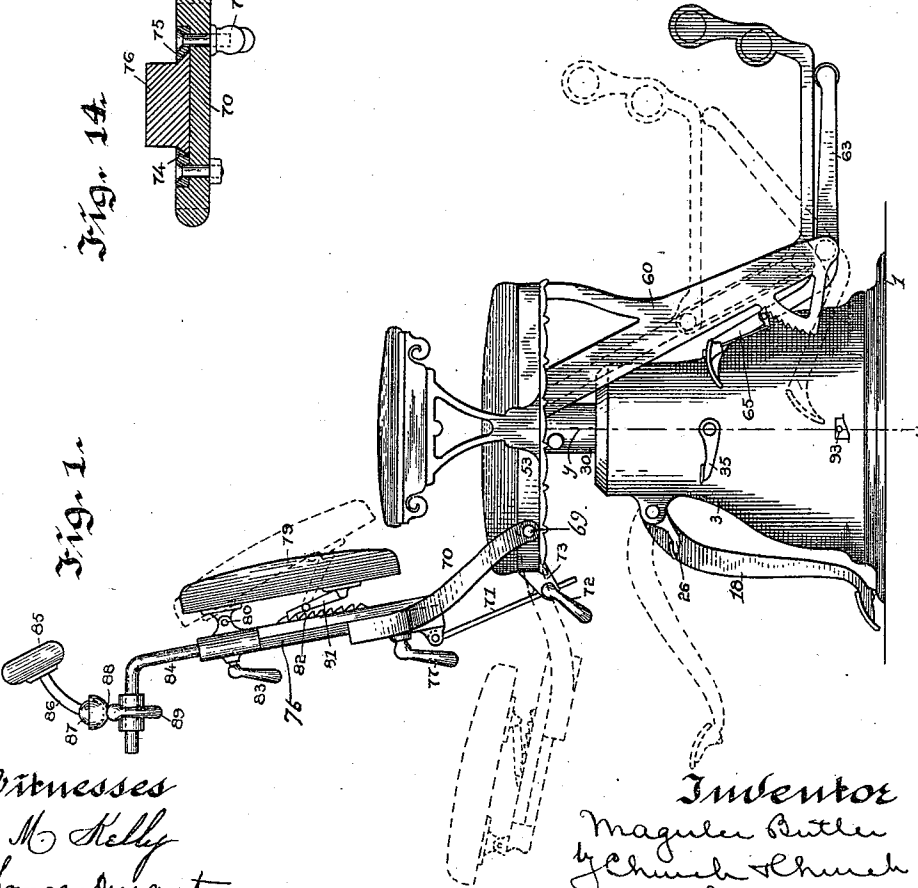

Fig. 1.

Witnesses
A. M. Kelly
Thomas Durant

Inventor
Maguel Butler
by Church & Church
his atty

(No Model.)

3 Sheets—Sheet 2.

M. BUTLER.
DENTAL CHAIR.

No. 490,637.

Patented Jan. 31, 1893.

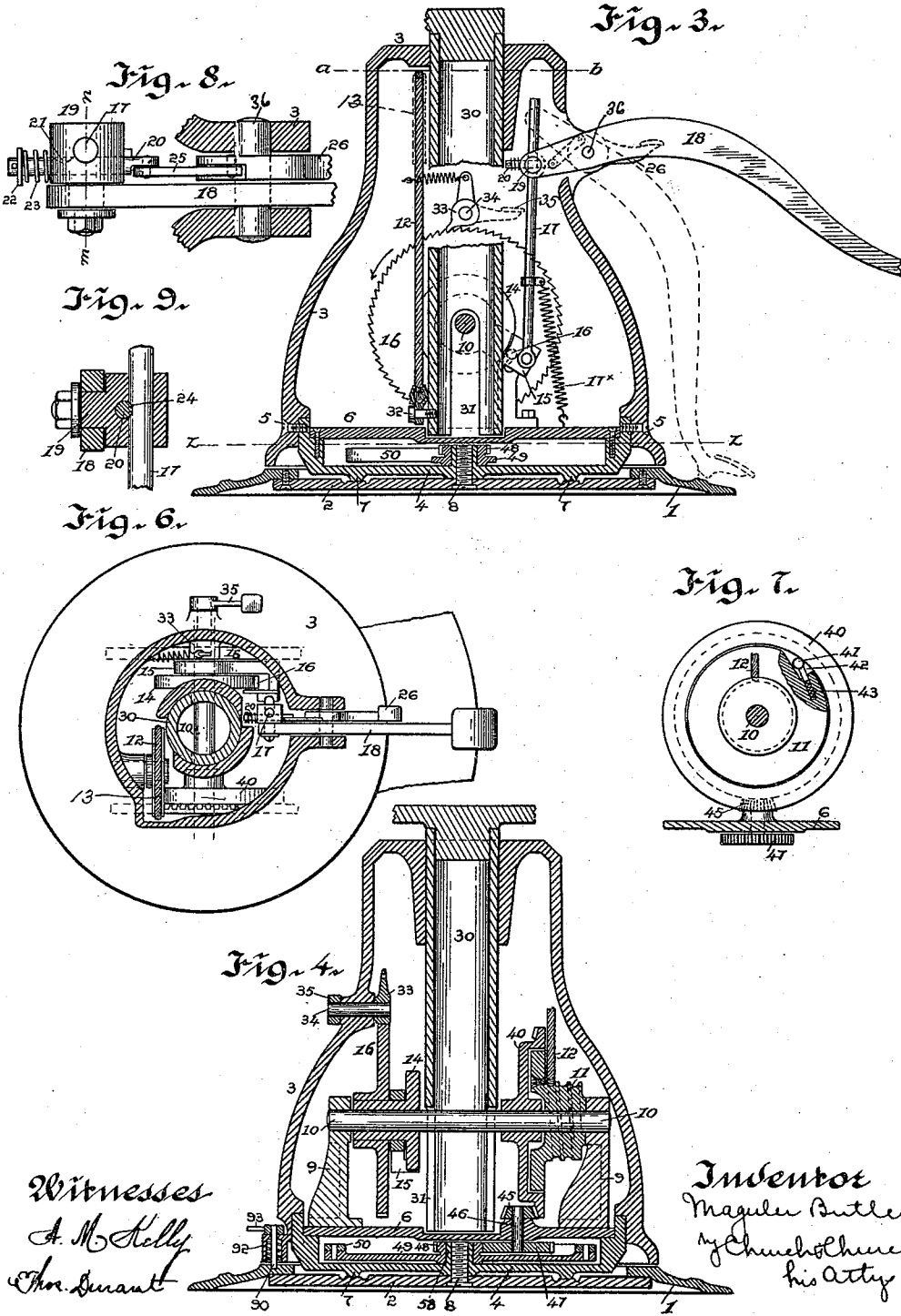

Witnesses
A. M. Kelly
Chas. Duant

Inventor
Magalen Butler
by Church & Church
his Atty

M. BUTLER.
DENTAL CHAIR.

No. 490,637.

Patented Jan. 31, 1893.

Fig. 5.

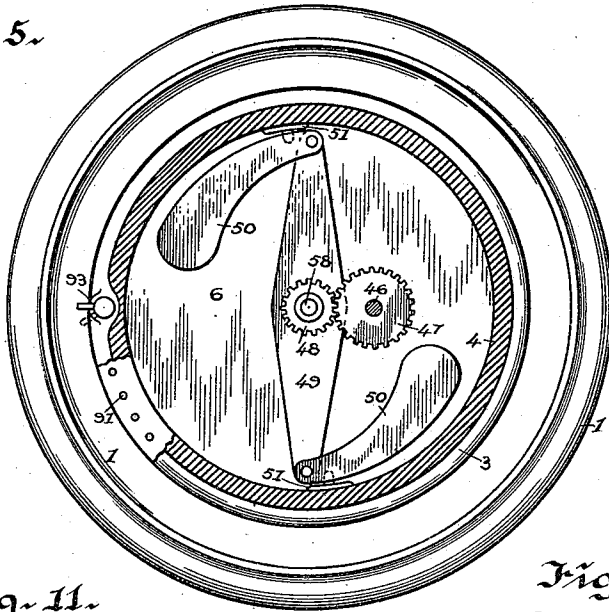

Fig. 11.

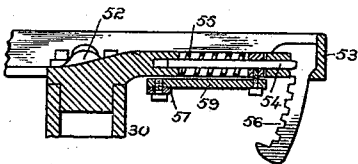

Fig. 10.

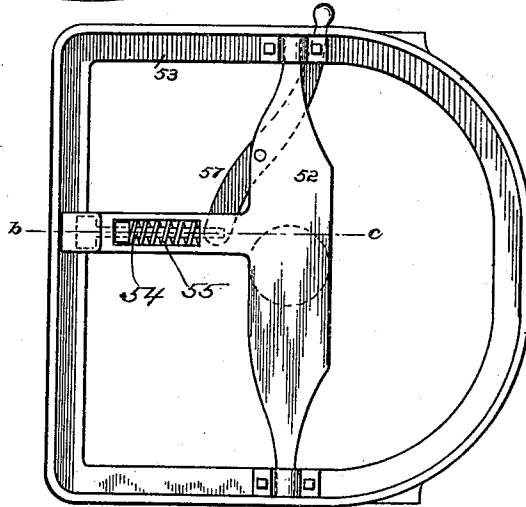

Fig. 12.

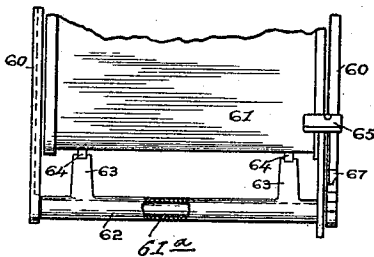
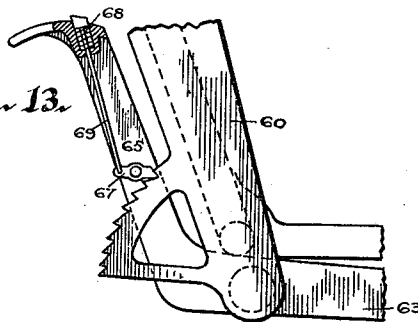

Fig. 13.



Witnesses
A. M. Kelly
Thos. Stewart

Inventor
Maurice Butler
by
John H. Church
his Atty.

UNITED STATES PATENT OFFICE.

MAGULER BUTLER, OF ROCHESTER, NEW YORK, ASSIGNOR OF ONE-HALF
TO THE ARCHER MANUFACTURING COMPANY, OF SAME PLACE.

DENTAL CHAIR.

SPECIFICATION forming part of Letters Patent No. 490,637, dated January 31, 1893.

Application filed February 15, 1892. Serial No. 421,587. (No model.)

To all whom it may concern:

Be it known that I, MAGULER BUTLER, of Rochester, in the county of Monroe and State of New York, have invented certain new and useful Improvements in Dental Chairs; and I do hereby declare the following to be a full, clear, and exact description of the same, reference being had to the accompanying drawings, forming a part of this specification, and to the reference-numerals marked thereon.

My present invention relates to dental and similar chairs and it has for its object to provide a chair that may be raised and lowered noiselessly and with facility and one in which the various adjustments necessary to put the patient in the most convenient position can be easily and quickly accomplished, and to these ends it consists in certain novelties in construction and combinations of parts, all as will be hereinafter fully described and the novel features pointed out in the claims at the end of this specification.

In the accompanying drawings: Figure 1 is a side elevation of a chair constructed in accordance with my invention showing in dotted lines some of the adjustments of which it is capable. Fig. 2 a rear elevation of the same. Fig. 3 a vertical section of the supporting base and standard taken on the line $x-x$ of Fig. 2. Fig. 4 a similar view taken on the line $y-y$ of Fig. 1. Fig. 5 a horizontal sectional view on the line $z-z$ of Fig. 3. Fig. 6 a horizontal sectional view on the line $a-b$ of Fig. 3. Fig. 7 a detail view of the winding drum and clutch. Fig. 8 a detail plan view of the device for disengaging the operating treadle. Fig. 9 a section on the line $m-n$ of Fig. 8. Fig. 10 a plan view of the seat frame. Fig. 11 a sectional view of the same on the line $b-c$. Fig. 12 a rear view of a portion of the foot rest or platform. Fig. 13 a side elevation of the platform adjusting mechanism partly in-section. Fig. 14 a sectional view of the back clamp taken on the line $e-f$ of Fig. 2.

Similar reference numerals in the several figures indicate similar parts.

The base or support for the chair, in which the seat supporting standard moves, is constructed, as shown in Figs. 1 to 4, of two parts, the lower part embodying a ring casting or base plate 1 adapted to rest upon and, if de-

sired, be secured to the floor, and to the inner edges of this is bolted or otherwise secured a plate 2 upon which the upper part of the base rests, said two parts being made integral however, if preferred. The upper part is composed of a column or casting 3 to the lower part of which is attached a dish-shaped casting 4, by means of securing screws 5 passing through the part 3 and the upturned edges of the casting. Also secured to this casting 4 is a plate 6.

The casting 4 is provided with a depending flange 7 resting upon the plate 2 and forming a small surface upon which the part 3 or column of the base may be rotated, it being centered and afforded a slight bearing at the center by means of a screw 8 passing up from the bottom and preventing its removal from the plate 2.

Mounted upon the cover plate 6 are suitable standards 9 in which are journaled the ends of a shaft 10 extending transversely of the base and having near one end and rigidly secured to it, a drum 11 preferably grooved spirally to receive a lifting rope or cable 12 to one end of which it is secured. At the other end of said shaft and rigidly secured to it is a ratchet wheel 16 and connected to this a disk 14 and sleeved upon the shaft, or an extension of the disk 14, is a loose arm 15 having a portion projecting over the periphery of the disk 14, between which and the disk operates a small roller 16, the edge of the projection over the disk being inclined so that when the arm 15 is raised by means of a pitman 17 attached to the foot lever 18, the roller will bite on the periphery of the disk and turn the latter and shaft in the direction indicated by the arrow Fig. 3. The clutch is retracted after being operated by the foot lever by means of a spring 17^x connected to the pitman and base. The connection between the clutch and the foot lever 18, (which latter is pivoted upon a pin 36 mounted in ears in the base and extending outward in convenient position to be operated upon,) is preferably detachable so that after the chair has been raised to the height desired, the operator may disconnect the foot lever 18 and allow it to move down out of the way, as shown in dotted lines Fig. 3.

One form of connection which I have employed with success, and prefer on account of its simplicity, is shown in detail in Figs. 8 and 9 and in this arrangement I pivot loosely upon the end of the lever, a stud 19 having a transverse aperture through which passes the pitman 17 connected to the clutch, and I provide in the stud and extending at right angles to said aperture, a sliding pin 20 having a recess 21 in its side, as shown in dotted lines Fig. 8, and to its outer end is secured a washer 22 between which and the stud is arranged a spring 23, adapted to move the pin in a direction to cause the solid portion to engage a suitable notch 24 provided in the side of the pitman 17. Connected to the other end of said pin is a link 25 pivoted to a small foot lever 26 journaled on the pivot pin 36 of the foot lever 18; the construction being such that under ordinary circumstances the pin 20 is projected by its spring so that it will be in engagement with the notch 24 in the pitman and the movements of the lever will be communicated to the latter, but when it is desired to disconnect the lever, it is only necessary for the operator to press with his foot on the end of the lever 26 drawing the pin 20 outward until the recess 21 is in line with the pitman, when the latter and its clutch will be drawn to lowest position by the spring 17^x and the lever will also drop to the position in dotted lines Fig. 3, the pin 20 being held retracted against the tension of its spring 23 as the notch 21 is in engagement with the solid part of the pitman. When it is desired to use the foot lever again, it is only necessary to raise it until the pin 20 is in line with the notch 24 when the spring will cause its re-engagement and the lever may then be operated in the usual way to raise the standard.

The standard 30 slides within the column 3 of the base, having a long bearing at its upper end and its lower end is provided with a slot 31 for the accommodation of the shaft 10 when the standard is lowered, and connected to the lower part of said standard by means of a screw 32 is one end of the cable 12, which extends over the pulley 13 journaled in the upper portion of the base and down again to the drum 11 to which it is secured.

It will be seen that in order to raise the chair it is only necessary to operate the foot lever in the usual manner (the spring 17^x returning it to highest position) when the disk 14 and shaft 10 will be rotated in the direction of the arrow Fig. 3, winding the cable 12 on the drum, the standard then being held by means of a spring pawl 33 secured to a shaft 34 extending to the exterior of the standard of the column and provided with a foot lever 35, said pawl arresting the backward rotation of the shaft 10 and the consequent unwinding of the cable from the drum.

It is necessary to supply some means for governing the backward movement of the winding drum in order to provide for an easy

and smooth descent of the standard carrying the chair seat and to provide for this, I journal loosely upon the shaft 10 a wheel 40 provided with a rim overhanging the enlarged end of the drum 11 and arrange between said drum and wheel a clutch device, whereby the drum may be rotated freely in a direction to wind up the cable and elevate the seat standard but when rotated in an opposite direction will cause the engagement of the drum and wheel, so that the latter will move with it. This clutch may be of any suitable construction but I prefer to employ a small roller 41 arranged in a tapering recess 42 in the drum and pressed outward by a spring 43 acting upon a suitable pin or follower.

Upon the outer side of the wheel 40 are gear teeth meshing with a small beveled pinion 45 secured to the upper end of a short shaft 46 journaled in the plate 6 and upon the lower end of this shaft is secured a pinion 47 meshing with a gear 48 secured to a spider 49 journaled loosely upon a boss or extension 58 of the casting 4, as shown in Figs. 3 and 4, and adapted to rotate loosely thereon. At the outer ends of the spider are pivoted weighted levers 50, and brake shoes 51 are arranged near the pivotal points of these levers and adapted to be pressed by them into engagement with the vertical rim of the casting 4, as in Fig. 5.

The operation of this governing device will now be apparent. When the shaft 10 is rotated in a direction to lower the chair seat by the weight of the parts and the occupant, the clutch between the drum and wheel 40 will be automatically engaged and said wheel will be rotated, actuating the spider 49 through the gears as described, and causing the weighted arms 50 to fly outward by centrifugal force, pressing the shoes 51 into engagement with the ring of part 4, this friction being sufficient to regulate and govern the descent, which can be arrested at any time by the operator allowing the pawl or detent 33 to engage the ratchet wheel 16.

Secured to the upper end of the seat standard 30 is a head or casting 52 having laterally projecting arms upon which the seat frame 53 is pivoted in the usual manner, said casting being also provided with a forward extension in which operates a bolt 54 normally pressed outward by a spring 55 to engage one of a series of recesses in a depending arm 56 secured to the seat frame, by which means the seat frame is retained in position when adjusted on its pivots, and as a means for readily operating said bolt I provide a lever 57 pivoted on the casting and extending outward at one side of the chair as shown in Figs. 9 and 11, and connected to the bolt by a link 59.

Depending from the forward portion of the seat frame are the slotted arms or plates suitably grooved or recessed on their inner side forming ways in which slide the platform

or foot rest 61 of the chair, the platform having suitable lugs or projections, for preventing tilting, fitting the ways.

The lower ends of the arms 60 are connected by a bolt or rod 61^a and surrounding this is a sleeve 62 having a bearing on the rod, to the forward portion of which are attached two arms 63 provided with rollers 64 on their ends in engagement with the under side of the platform and serving to support it. Near one end of the sleeve 62 is secured a foot lever 65 extending rearward and out at one side of the depending arm 60 where it projects slightly over the rack segment 66 secured to or formed upon the arm 60. Pivoted upon the lever is a pawl 67, the free end of which is held in engagement with the ratchet teeth by a spring 68 encircling a release rod 69 the latter being pivoted to the pawl and having its upper end extending through the tread portion of the foot lever. It will be seen that the operator can raise the foot rest or platform by pressing on the lever 65, the pawl sliding over the ratchet teeth and the arms 63 lifting the said platform in its guides and when he desires to lower it, it is only necessary to press on the end of rod 69 with his toe, releasing the pawl, when he can govern the descent with his foot as will be understood.

The arms 63 and 65 constitute in effect but a single lever pivoted upon the cross rod and while I prefer the arrangement shown, this construction could be modified materially and produce the same result.

Pivoted to the rear of the seat frame at 69 is a casting or frame 70 on which the chair back is supported said frame being maintained in vertical position by a rod 71 pivoted to it and extending through a pivoted clamping bolt or stud 72 journaled in a lug 73 on the back of the seat frame and fastened in any position to which it may be adjusted by a handle 73, this construction being such that the back can readily be lowered to almost a horizontal position, as in dotted lines Fig. 1, or otherwise adjusted on the pivot as desired.

To the front of the frame 70 are secured plates 74, 75, having the undercut edges and forming ways in which the slide 76 carrying the back support operates, the rear of the slide being formed with a corresponding dovetail projection. The plate 75 can be adjusted by means of handle 77 so that the slide can be moved and then secured rigidly in position. 79 indicates the padded chair back pivoted at 80 to the upper portion of the slide 76 and near its lower portion is pivoted a pawl 81 adapted to engage with the teeth of a rack 82 on the slide to adjust the inclination of the back, as shown in dotted lines.

Sliding in a socket in the upper part of the slide 76 and adapted to be secured in position by a clamping screw 83 is a bent rod 84 on which the head rest is supported, said head rest consisting of the usual pad 85 to the rear

side of which is connected a stem 86 having a ball 87 on its end adapted to be received in and secured by the clamp 88. This clamp consists of two co-operating sections connected by a hand screw 89, their upper portions when together constituting a spherical socket for receiving the ball 87 on the head rest stem, while their lower ends are provided with the semi-cylindrical grooves fitting the sides of the horizontal portion of the rod 84, the parts being so arranged that by a single movement of the hand screw, the head rest can be loosened and adjusted, not only by moving the ball around in its socket but the whole clamp can be moved along on the rod 84 or around it, as may be desired. The advantages of this construction of head rest will be at once apparent, as with a single clamping screw all the necessary motions of the pad or head rest proper are controlled. The construction of the back and the parts supported upon the seat frame also enables me to obtain all the adjustments necessary to put the patient in the most comfortable and convenient position to be operated upon.

The whole chair may be rotated around on the part 1,—2, of the base with the securing screw 8 as a center, the flange 7 offering but little frictional resistance on the plate 2 and in order to secure it in any position desired I provide a bolt 90 in the lower portion of the part 3 of the base, pressed downward into one of a series of holes 91 formed in the top of plate 1, by a spring 92 and adapted to be lifted and held out of engagement, when desired, by an arm 93 engaging the inclined or cam surface formed on the base when turned to one side as in Fig. 5, in dotted lines.

I claim as my invention.

1. In a chair, the combination with the seat standard, of the rotatable base in which the standard is movable, the winding drum, the cable connecting the standard and drum, the shaft carrying the drum, the ratchet wheel on the shaft, the pawl engaging with it, the clutch wheel, the clutch and means for actuating the latter, all said parts being located within the base, substantially as described.

2. In a chair, the combination with the seat standard of the base in which it operates, the winding drum, the cable connected to the drum and standard, clutch mechanism for operating the drum, retaining devices for arresting backward movement the speed governor and a clutch between said drum and governor permitting the independent rotation of the drum to raise the standard, but causing its automatic engagement with the governor when rotated in the opposite direction, substantially as described.

3. In a chair, the combination with the base, the seat standard the cable, the shaft having the drum, the ratchet wheel and clutch devices actuated from the exterior of the base, of the speed governor, the gear on the shaft connected with the governor, and the clutch between the gear and drum whereby the drum

may be actuated to raise the standard independently of the gear but is automatically connected thereto when rotated in the opposite direction, substantially as described.

5 4. The combination of the base 3, the seat standard operating therein, the rotating shaft in the base having the winding drum, ratchet and clutch wheels thereon, the clutch and dent, the cable connecting the drum and
10 standard, a speed governor and a clutch between the drum and governor for automatically causing their connection when the drum is rotated in one direction, substantially as described.

15 5. The combination with the base 3, the seat standard operating therein, the shaft, the drum fixed on the shaft, the lifting cable, the gear loose on the shaft and the clutch between it and the drum, of the speed governor and
20 gearing between it and the first mentioned gear, of clutch devices for rotating the drum and devices for securing it from backward rotation, substantially as described.

25 6. The combination of the base, the seat standard, the shaft, the drum, the cable connected to the standard and drum, the gear, and a clutch connecting it with the drum when
30 the latter moves in one direction, the vertical shaft having the pinion in engagement with the gear, the horizontally rotating spider having the gear and the weighted brake shoes and the gear on the vertical shaft engaging the one on the spider, substantially as described.

35 7. The combination with the base or column containing the lifting mechanism and the seat standard operating therein, the base casting 4 secured to the column having the central boss, the spider mounted thereon having the
40 weighted brake arms co-operating with the rim of the casting constituting a speed governor, and gearing connecting the spider with the lifting mechanism, of the base plate and the pivot bolt entering the casting 4 and securing it to the said plate, substantially as
45 described.

50 8. In a chair, the combination with the base, seat standard, and the lifting mechanism for the latter having the movable pitman, of the lifting lever pivoted in the base, the stud on the lever embracing the pitman and detachable connections between said stud and the pitman, whereby the lever may be disconnect-

ed and allowed to fall beside the base, substantially as described.

55 9. The combination with the chair base, the pivoted lever, having the stud and spring projected bolt, of the pitman having the recess with which the bolt co-operates for locking it to the pitman and means for operating said
60 bolt, substantially as described.

10. The combination with the chair base, the pivoted lever the stud mounted thereon having the spring projected bolt, the lever connected to said bolt and adapted to be operated from the exterior of the chair base, of
65 the pitman connected to the seat lifting mechanism passing through the stud and having the recess with which the bolt co-operates, substantially as described.

70 11. The combination with the chair base, the pivoted lifting lever, the stud pivoted thereon having the aperture and the spring projected bolt, the lever mounted on the pivot of the lifting lever and the link connecting
75 it with the bolt, of the pitman connected to the seat lifting mechanism passing through the stud and having the recess with which the bolt co-operates, substantially as described.

80 12. The combination with the seat frame having the depending arms constituting guides and the segmental rack thereon, of the platform sliding in said arms, the foot lever pivoted on said depending arms having forwardly extending arms projecting beneath the
85 platform and on which it is supported and the spring operated pawl engaging the rack, substantially as described.

13. The combination with the seat frame having the depending arms constituting
90 guides, the bolt or rod connecting them and the segmental rack, of the platform sliding on said arms, the sleeve encircling the rod having the forwardly extending arms projecting beneath and supporting the platform, the
95 rearwardly projecting foot lever, the spring pawl thereon co-operating with the rack, the rod connected to the pawl arranged in proximity to the tread of the lever, whereby the operator may operate the foot lever to raise
100 the platform or release the pawl and govern its descent, substantially as described.

MAGULER BUTLER.

Witnesses:

FRED F. CHURCH,
A. A. DAVIS.