

US RE46,308 E

(56)	References Cited	4,962,749 A	10/1990	Dempsey et al.	F23N 1/062 126/110 E
	U.S. PATENT DOCUMENTS	4,965,707 A	10/1990	Butterfield	F24C 7/004 362/806
2,630,821 A	3/1953 Arey et al.	5,039,007 A	8/1991	Wolter	A47J 31/54 126/19.5
	F17C 13/045 116/277	5,090,899 A	2/1992	Kee	F23D 14/64 126/92 AC
2,661,157 A	12/1953 Reichelderfer	5,172,728 A	12/1992	Tsukazaki	F16K 1/446 137/240
	F23D 14/60 236/1 A	5,199,385 A	4/1993	Doss	F24H 1/205 110/162
2,687,140 A	8/1954 St. Clair	5,201,651 A	4/1993	Niksic et al.	F23N 1/027 126/110 B
	F17C 13/045 137/113	5,239,979 A	8/1993	Maurice et al.	F24C 3/022 119/304
2,750,997 A	6/1956 Reuter	5,251,823 A	10/1993	Joshi et al.	F23D 11/107 239/401
	F23D 14/64 239/536	5,314,007 A	5/1994	Christenson	B60H 1/3202 123/557
3,001,541 A	9/1961 Clair	5,391,074 A	2/1995	Meeker	F23N 5/105 110/186
	B60G 17/0525 137/113	5,393,222 A	2/1995	Sutton	F23N 5/10 431/328
3,082,305 A	3/1963 Wunder	5,413,141 A	5/1995	Dietiker	F23N 1/007 137/489
	H01H 37/52 219/510	5,452,709 A	9/1995	Mealer	F24C 3/006 126/512
3,139,879 A	7/1964 Bauer et al.	5,470,018 A	11/1995	Smith	F23N 1/007 126/116 A
	F23D 14/12 126/38	5,486,107 A	1/1996	Bonne	G01N 33/2829 374/43
3,265,299 A	8/1966 Rice et al.	5,503,550 A	4/1996	DePalma	F23D 14/72 126/292
	F23N 5/105 122/14.22	5,513,798 A	5/1996	Tavor	B05B 7/0475 239/405
3,295,585 A	1/1967 Kovack, Jr. et al. ...	5,542,609 A	8/1996	Meyers	B01F 5/08 239/427
	F23D 14/60 431/22	5,553,603 A	9/1996	Barudi et al.	F23D 14/60 126/512
3,331,392 A	7/1967 Davidson et al. ..	5,567,141 A	10/1996	Josh et al.	F23D 11/106 239/419
	F15B 13/0814 137/559	5,575,274 A	11/1996	DePalma	F23D 14/72 126/285 R
3,469,590 A	9/1969 Barker	5,584,680 A	12/1996	Kim	F24C 3/006 126/512
	F16K 31/0675 137/1	5,603,211 A	2/1997	Graves	F23C 7/002 60/39.48
3,590,806 A	7/1971 Locke	5,632,614 A	5/1997	Consadori et al.	F23N 5/082 219/260
	F24C 3/14 126/92 B	5,642,580 A	7/1997	Hess et al.	F21S 10/04 40/428
3,595,270 A	7/1971 McNeal, Jr.	5,645,043 A	7/1997	Long et al.	F24C 1/10 126/91 R
	F16K 11/202 137/575	5,674,065 A	10/1997	Grando et al.	F24C 3/006 126/512
3,706,303 A	12/1972 Hapgood	D391,345 S	2/1998	Mandir et al.	D23/339
	F23M 20/005 122/356	5,738,084 A	4/1998	Hussong	F24C 3/122 126/116 A
3,740,688 A	6/1973 McIntosh et al.	5,782,626 A	7/1998	Joos et al.	F23D 11/007 431/181
	F23N 5/025 337/407	5,807,098 A	9/1998	Deng	F23N 5/006 126/112
3,747,586 A	7/1973 Weiss	5,814,121 A	9/1998	Travis	C03B 5/2353 239/430
	F24H 9/2085 126/110 B	5,838,243 A	11/1998	Gallo	F23N 5/242 236/21 R
3,814,573 A	6/1974 Karlovetz	5,839,428 A	11/1998	Schroeter et al.	F24C 3/042 126/512
	F23D 14/145 431/329	5,906,197 A	5/1999	French et al.	F24C 15/02 126/512
3,817,686 A	6/1974 Quittner	5,915,952 A	6/1999	Manning et al.	F24C 3/122 431/12
	F23D 91/02 126/92 R	5,941,699 A	8/1999	Abele	F23N 5/107 126/92 AC
3,829,279 A	8/1974 Qualley et al.				
	F23D 14/62 431/354				
D243,694 S	3/1977 Faulkner				
	D23/339				
4,020,870 A	5/1977 Carlson				
	F16K 5/0214 137/625.3				
4,290,450 A	9/1981 Swanson				
	F16K 11/24 137/606				
4,340,362 A	7/1982 Chalupsky et al. ..				
	F24H 3/0488 431/353				
4,348,172 A	9/1982 Miller				
	F23Q 3/002 431/255				
4,355,659 A	10/1982 Kelchner				
	F16K 11/0856 137/597				
4,640,674 A	2/1987 Kitchen				
	F23C 15/00 431/1				
4,640,680 A	2/1987 Schilling				
	F23D 14/64 431/347				
4,651,711 A	3/1987 Velie				
	F24H 3/0488 126/110 B				
4,718,448 A	1/1988 Love et al.				
	F23N 1/005 137/271				
4,718,846 A	1/1988 Oguri et al.				
	F23N 5/006 126/92 AC				
4,768,543 A	9/1988 Wienke et al.				
	F16K 1/305 137/240				
4,768,947 A	9/1988 Adachi				
	F23N 1/022 122/14.21				
4,779,643 A	10/1988 Genbauffe				
	F16K 5/0207 137/599.17				
4,782,814 A	11/1988 Cherryholmes				
	F24C 3/14 126/92 B				
4,848,313 A	7/1989 Velie				
	F24H 3/0488 126/110 B				
4,930,538 A	6/1990 Browne				
	F16K 27/0263 137/269				

(56)

References Cited

FOREIGN PATENT DOCUMENTS

JP	2003074838	3/2003
WO	WO0050815 A1	8/2000

OTHER PUBLICATIONS

Comfort Glow; Vent-Free Gas Space Heaters; Ultra Slim; available as of Mar. 9, 2007.*

Comfort Glow; Vent-Free Gas Space Heaters; Solarfusion; available as of Mar. 9, 2007.*

Glo-Warm; Blue Flame Vent-Free Space Heaters; available as of Mar. 9, 2007.*

Reddyheater; Garage Heaters; The Outdoorsman; available as of Mar. 9, 2007.*

Vanguard; Single Burner 26" Compact; Dual burner 26" Compact; Classic Hearth 32"; Classic Pro 36"; available as of Mar. 9, 2007.*

Vent-Free Gas Log Heaters; Blaze N Glow Oak; available as of Mar. 9, 2007.*

Vanguard; Cast Iron Gas Stove Heaters; available as of Mar. 9, 2007.*

Vanguard; Vent-Free Gas Space Heaters; available as of Mar. 9, 2007.*

Hearth Sense; Dual Fuel; available as of Mar. 9, 2007.*

Napoleon; The Madison Installation and Operation Instructions; May 24, 2005.*

Napoleon; Park Avenue Installation and Operation Instructions; Jul. 20, 2006.*

Heat and Glo; Escape Series Gas Fireplaces; Mar. 2005.*

Heat and Glo; Owner's Manual; Escape-42DV; Dec. 2006.*

* cited by examiner

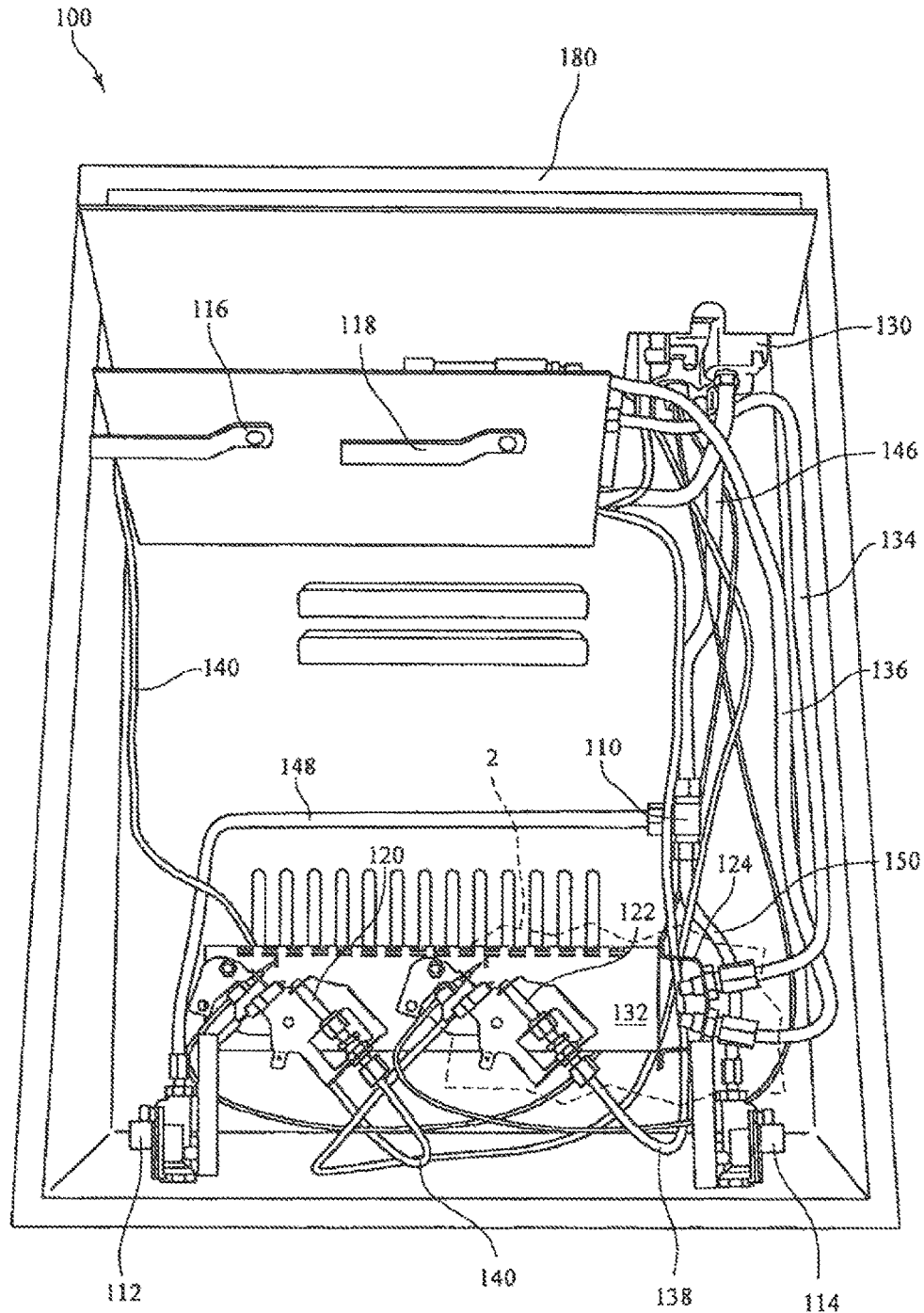

FIG. 1

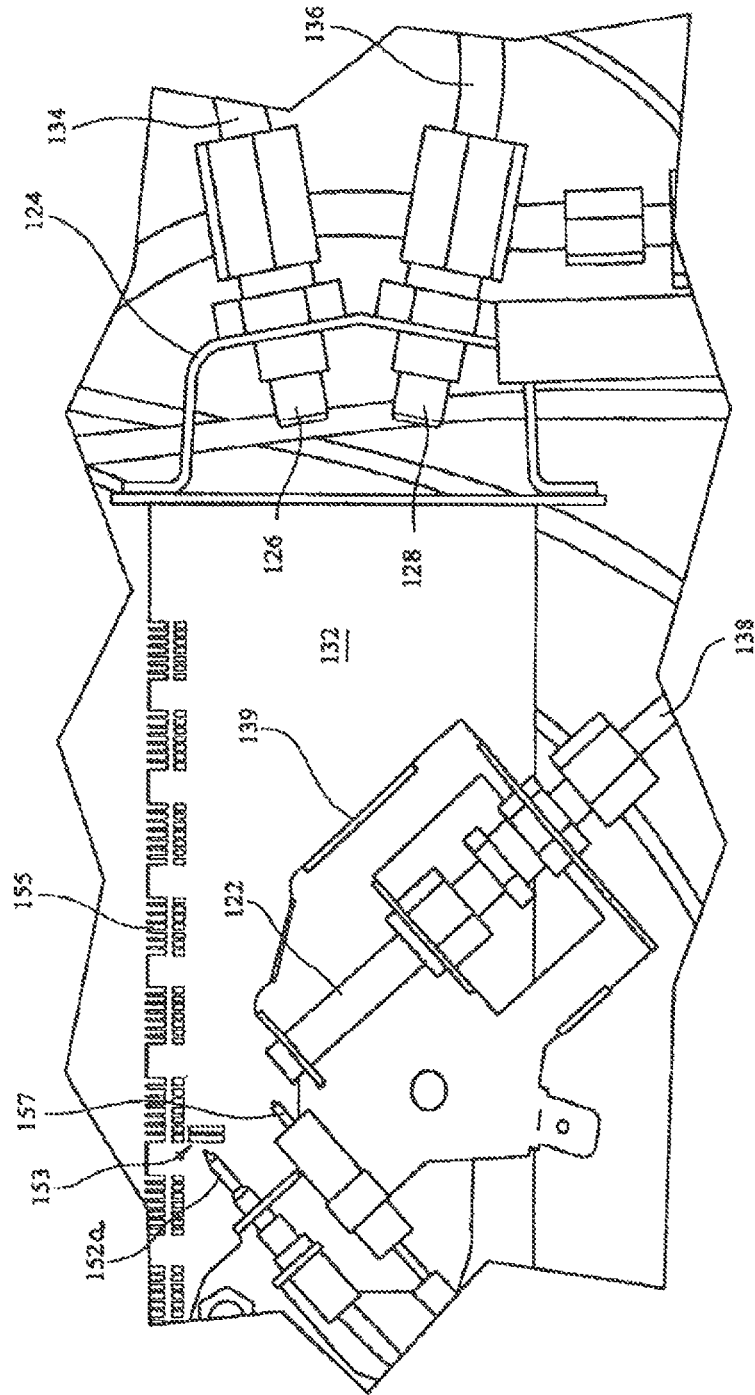

FIG. 2

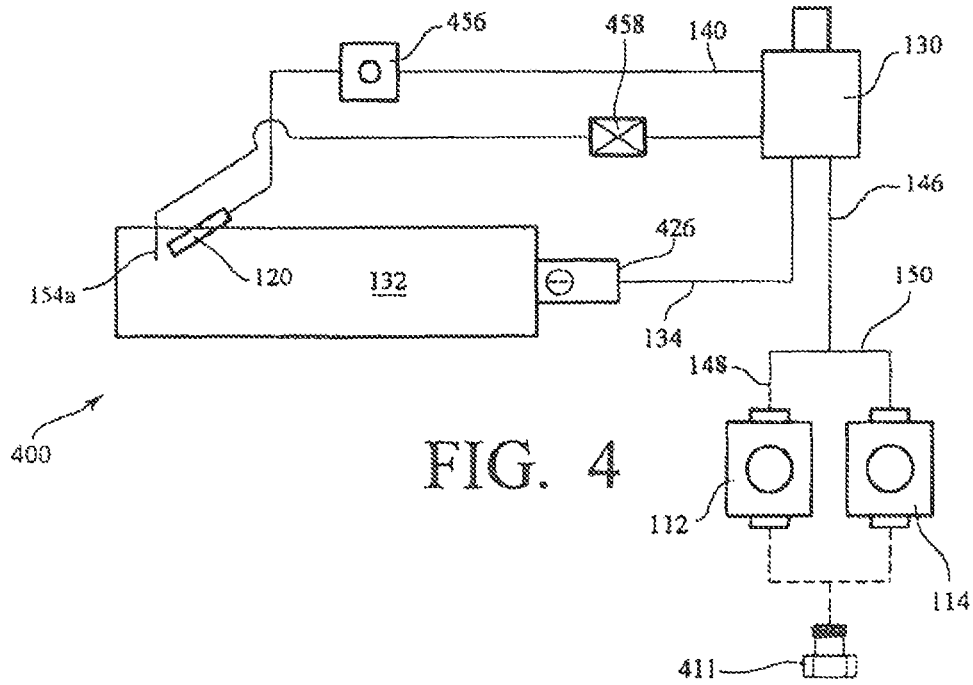

FIG. 4

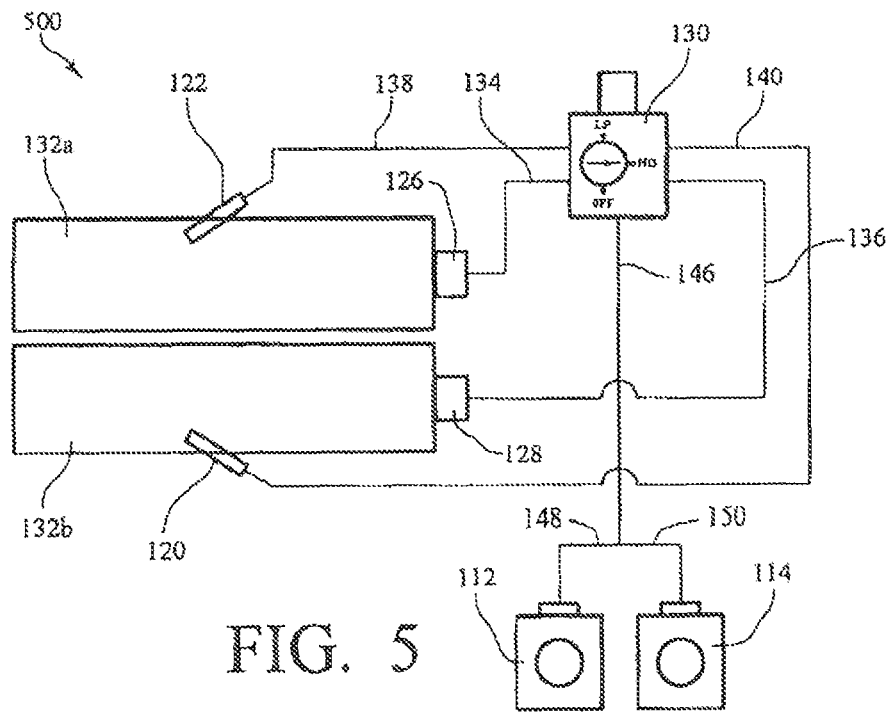

FIG. 5

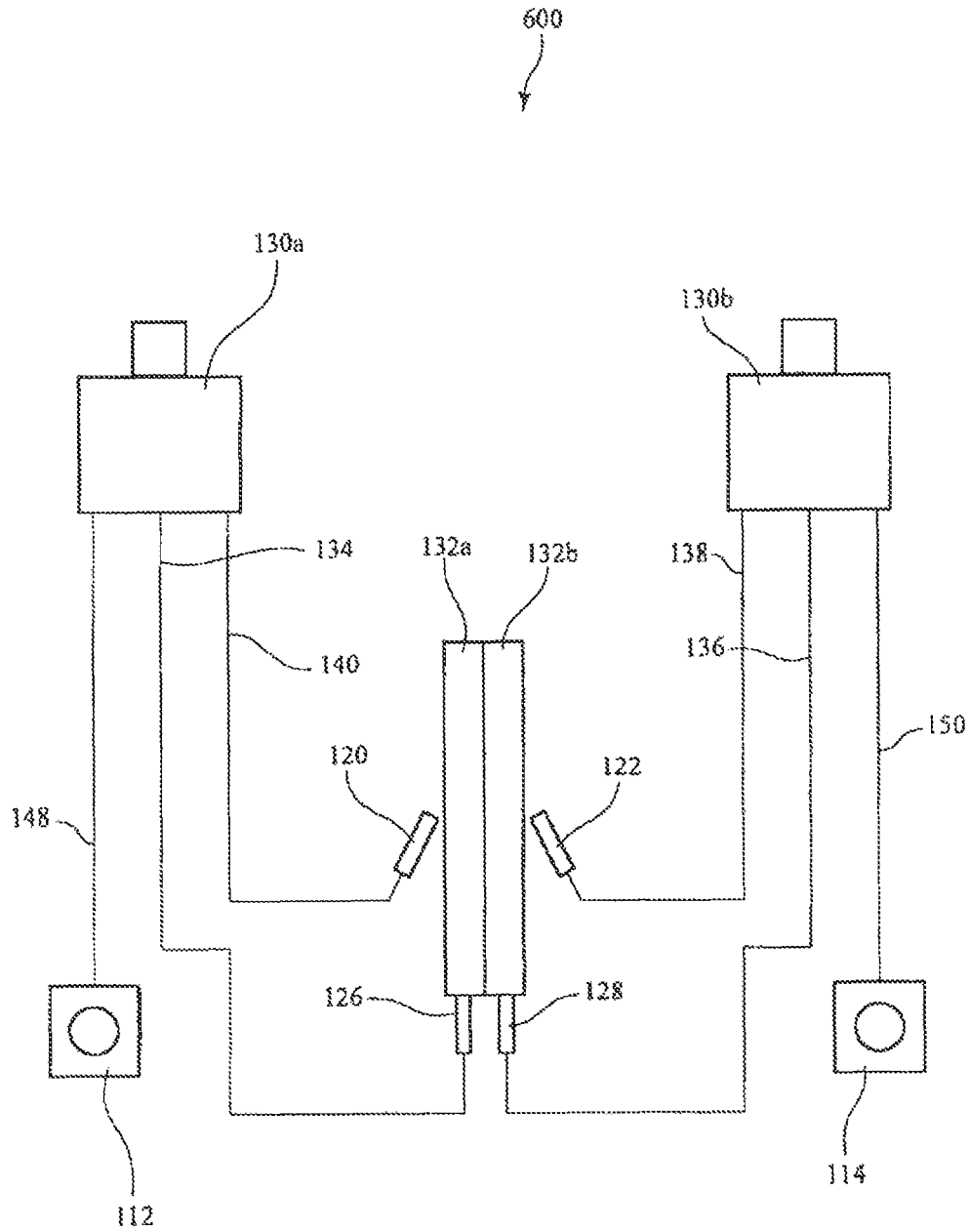

FIG. 6

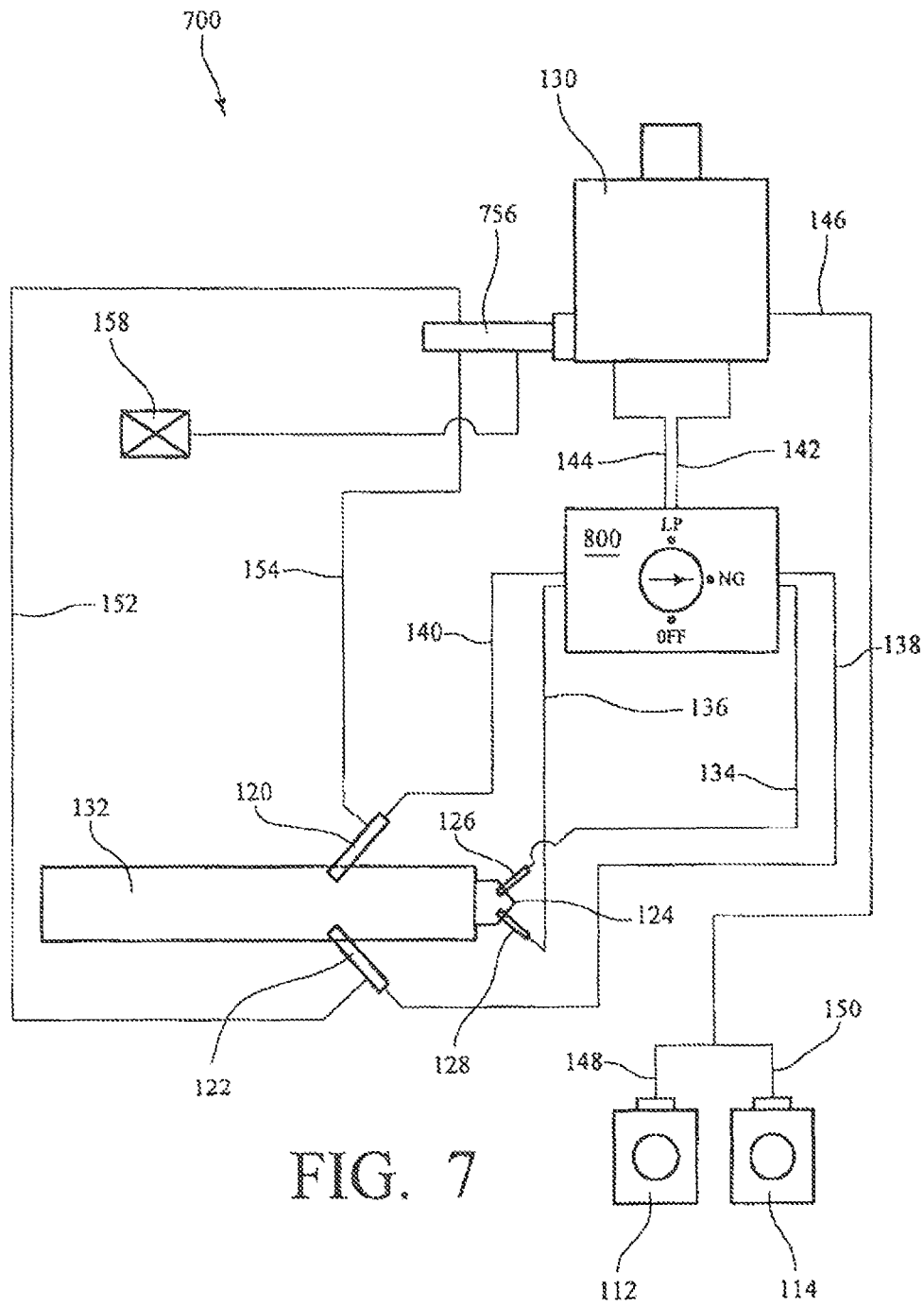
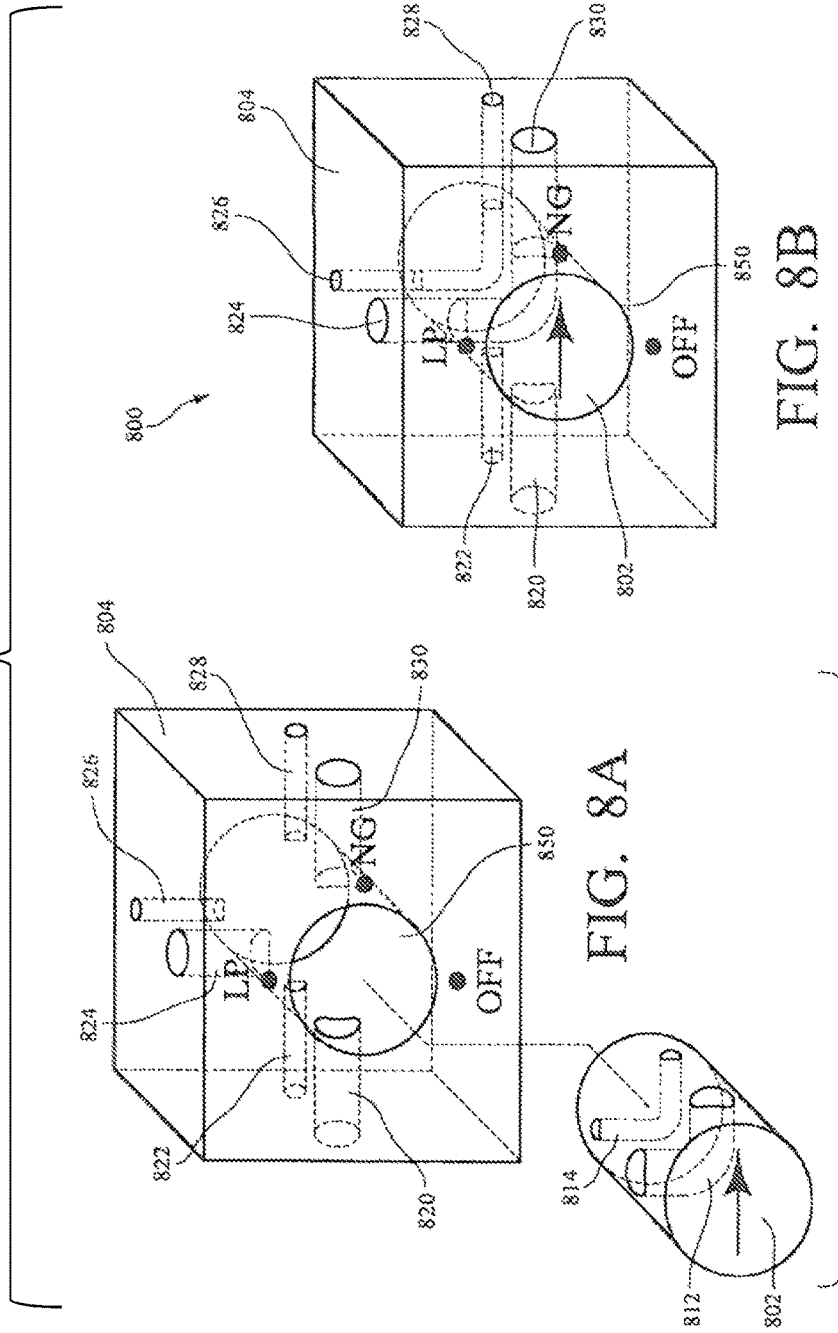

FIG. 7

FIG. 8



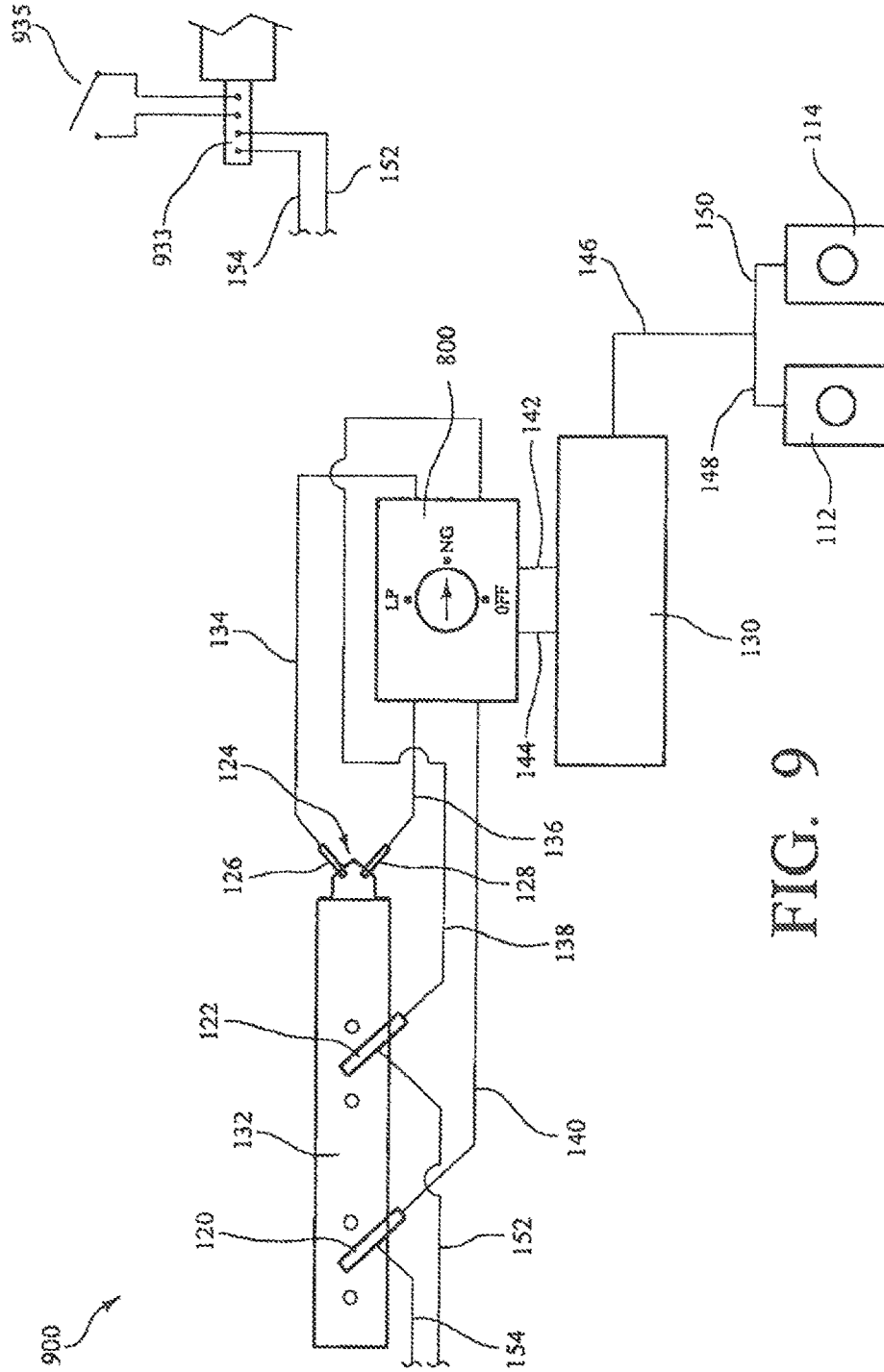

FIG. 9

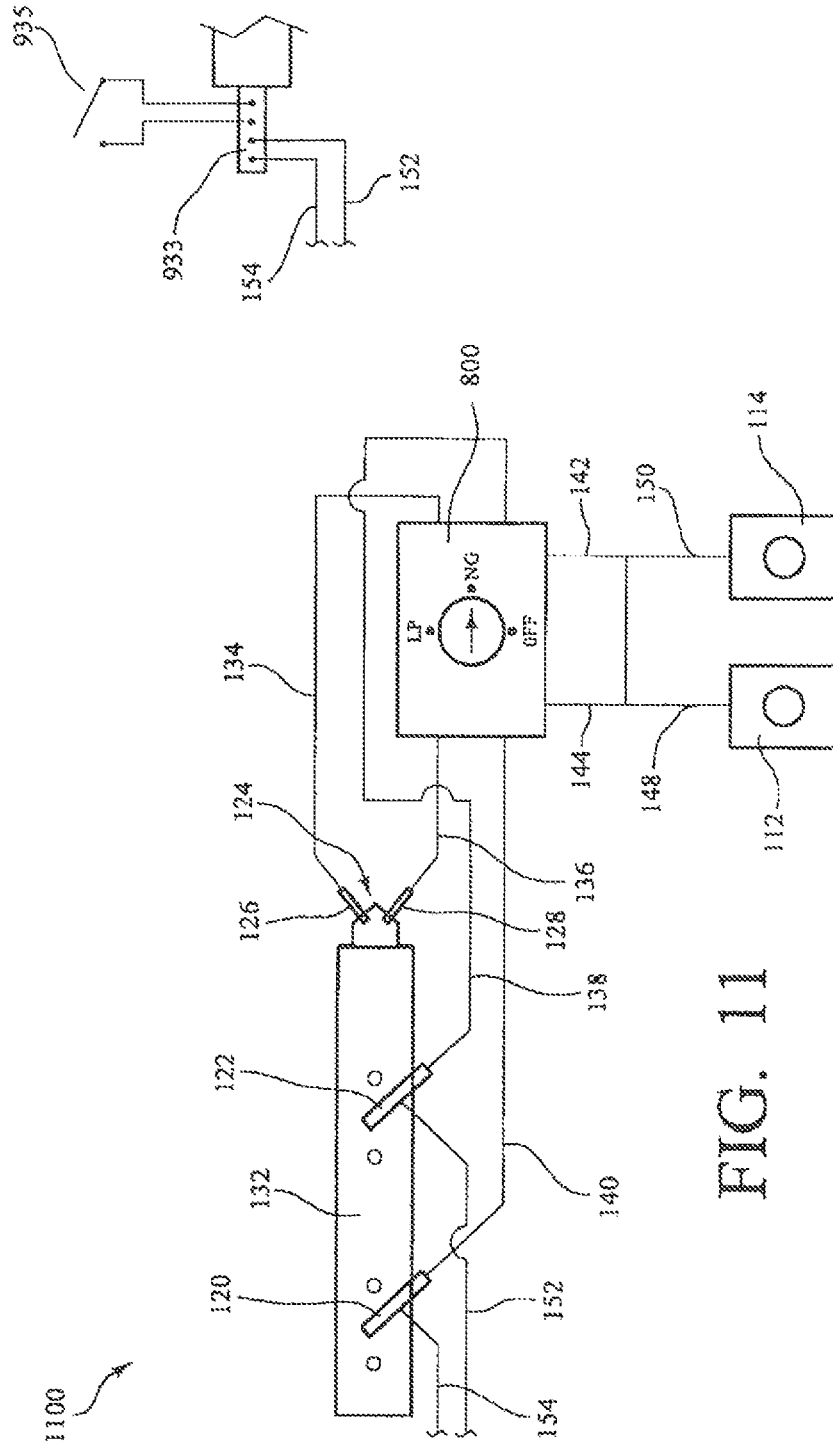

FIG. 11

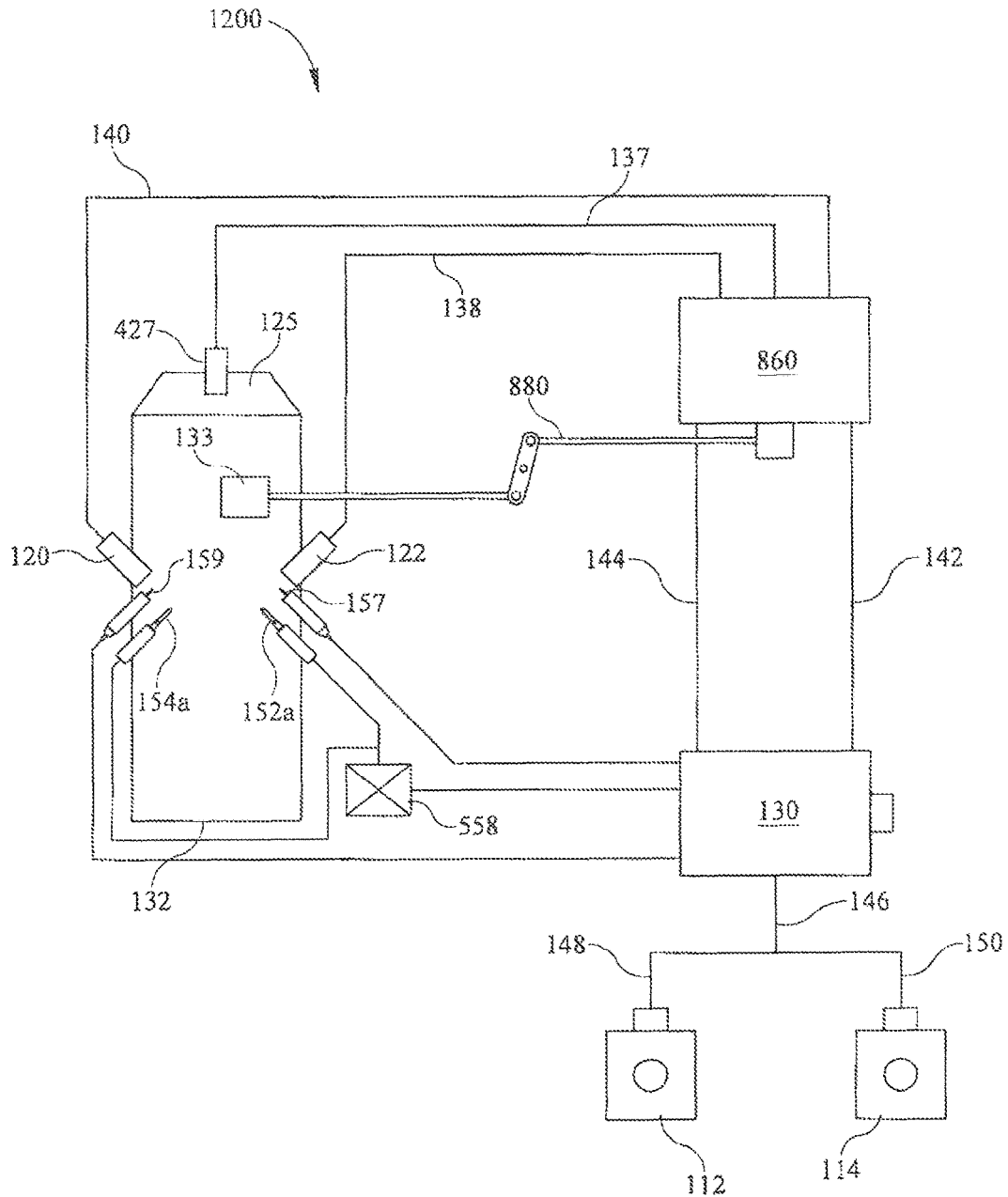

FIG. 12

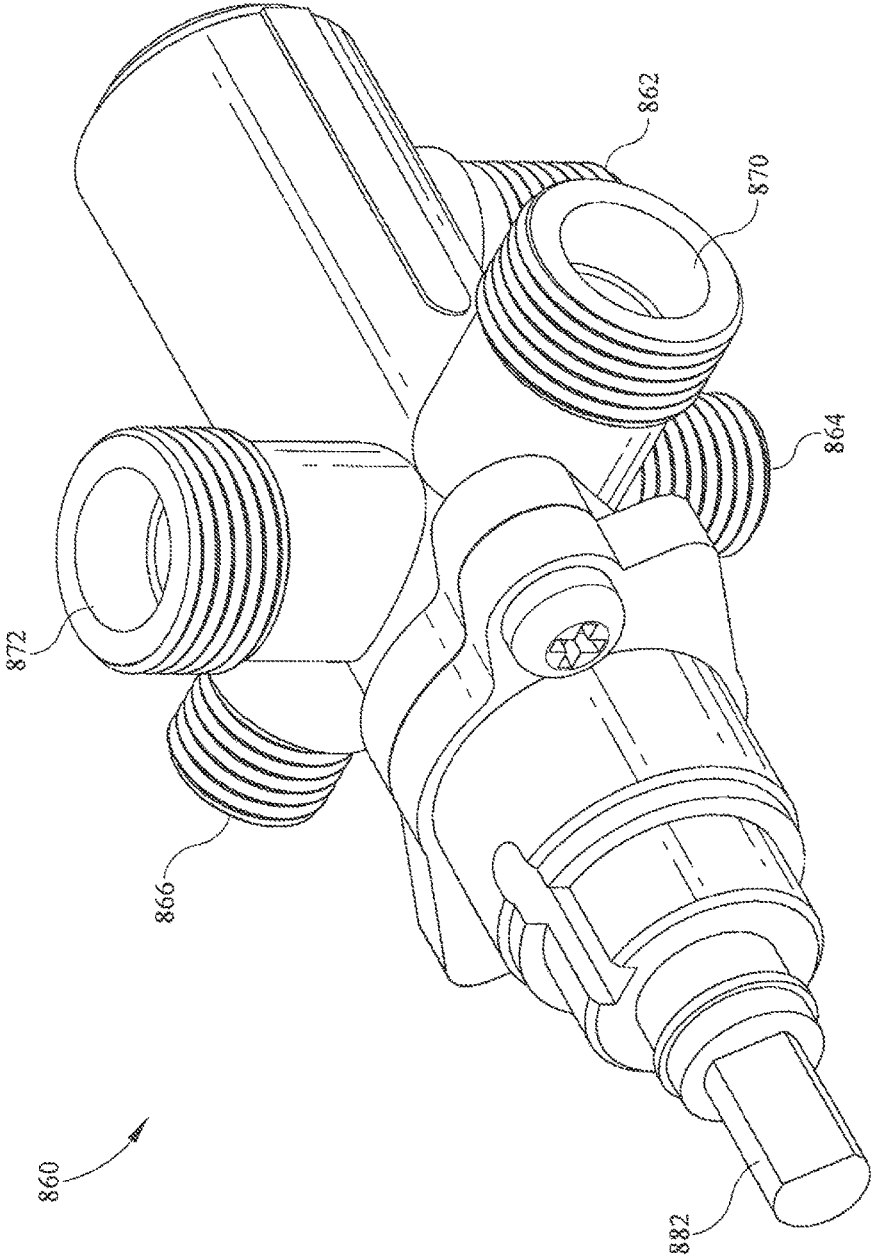

FIG. 13

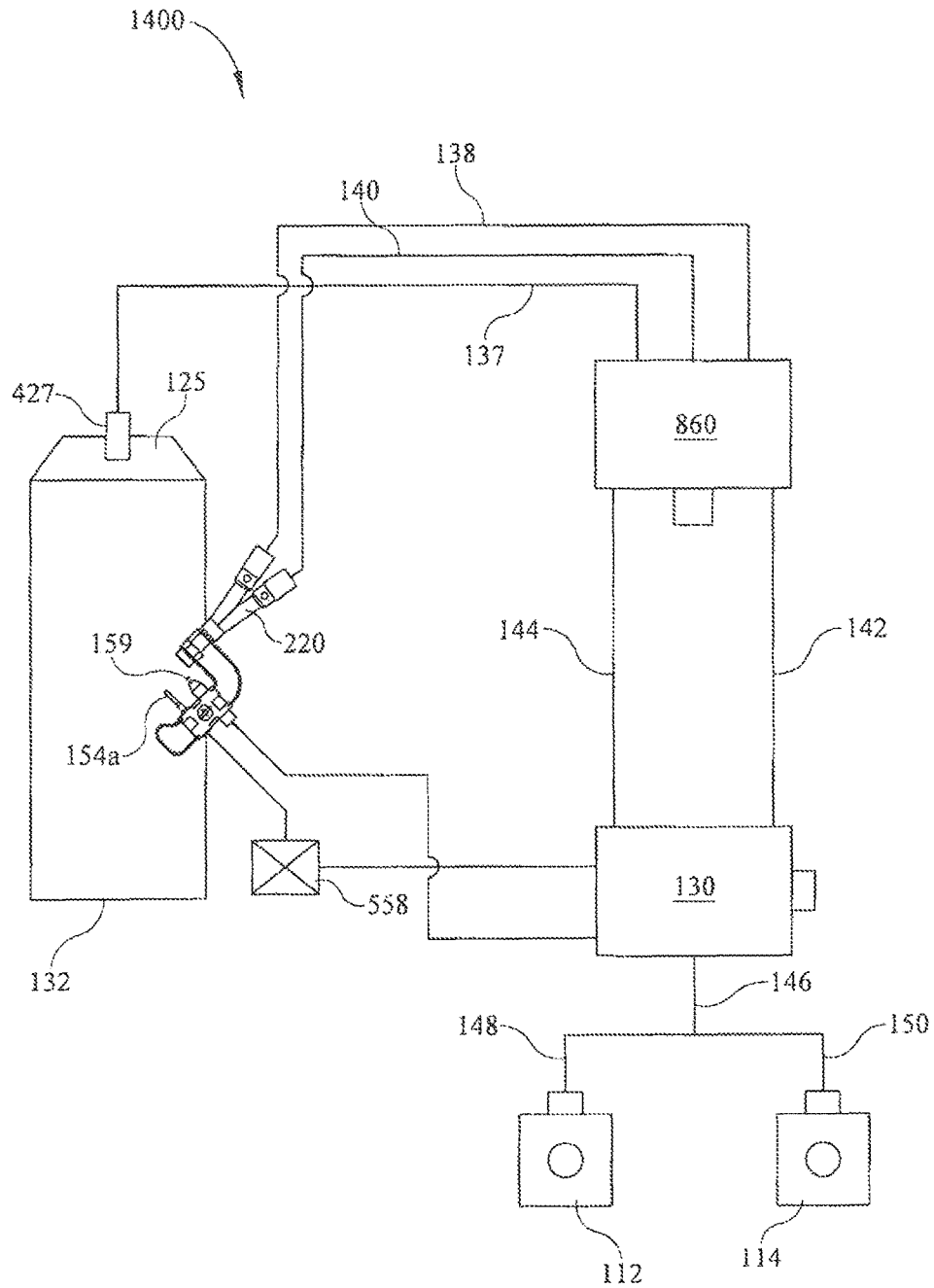

FIG. 14

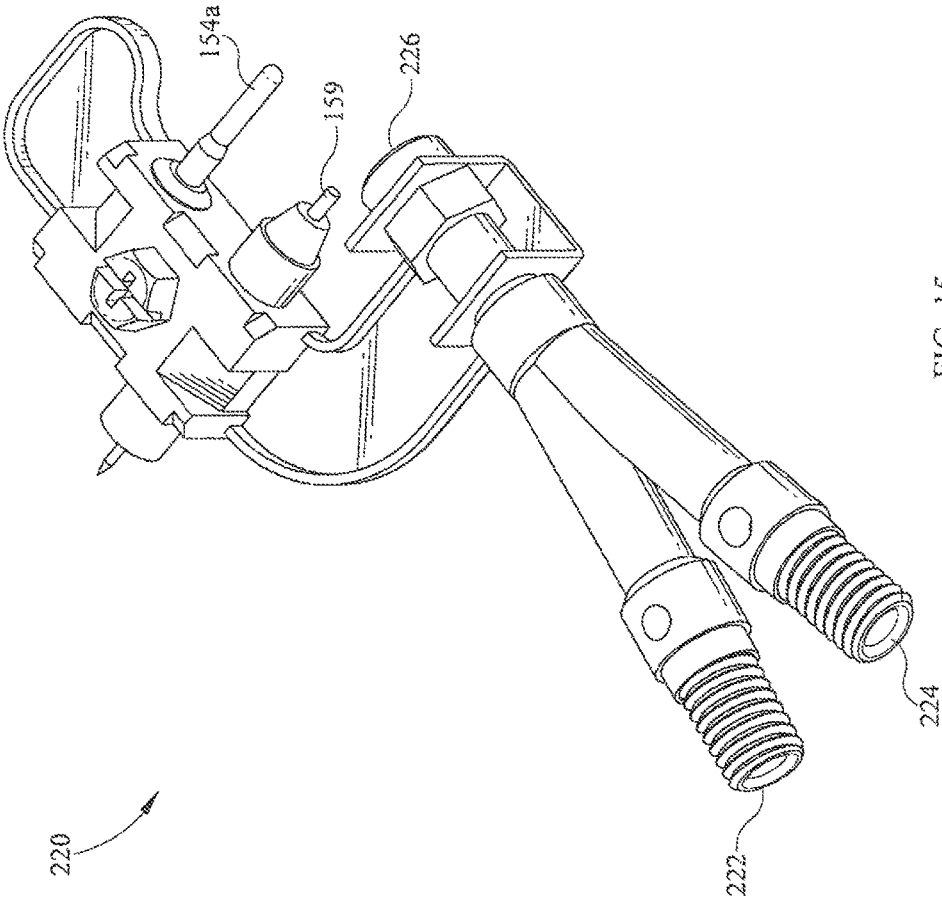

FIG. 15

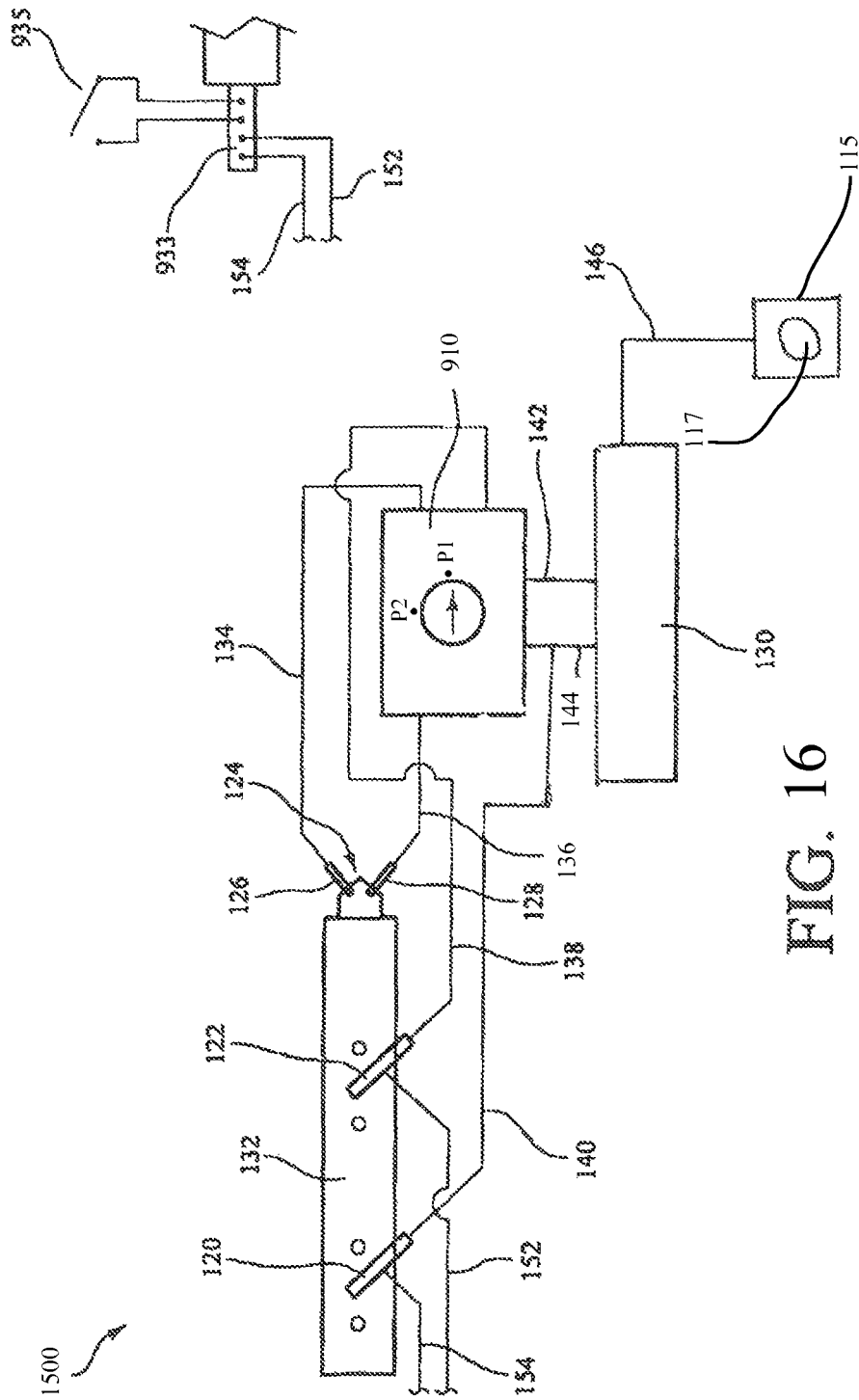

FIG. 16

DUAL FUEL HEATER

Matter enclosed in heavy brackets [] appears in the original patent but forms no part of this reissue specification; matter printed in italics indicates the additions made by reissue; a claim printed with strikethrough indicates that the claim was canceled, disclaimed, or held invalid by a prior post-patent action or proceeding.

CROSS-REFERENCE TO RELATED APPLICATIONS

This application is a continuation of U.S. application Ser. No. 13/278,931 filed Oct. 21, 2011, which is a continuation-in-part to U.S. application Ser. No. 12/237,131, filed Sep. 24, 2008, which is a continuation-in-part to U.S. application Ser. No. 11/684,368, filed Mar. 9, 2007.

TECHNICAL FIELD

The present invention relates generally to gas heaters and, more particularly, to unvented gas heaters.

BACKGROUND

Unvented gas heaters are designed to be used indoors without pipes, ducts, or other conduit to vent the heater's exhaust to the exterior atmosphere. Vent free gas heaters typically include one or more gas burners and optionally one or more ceramic containing heating elements in a housing and optionally one or more artificial logs. The gas and air mix in the heater where combustion takes place. These heaters may have a blower to force air flow through the heater providing the release of heated gases or convective heat.

Unvented gas heaters have been designed to be free standing, mounted on a wall, or in a decorative housing such as a vent free fireplace. The housing providing a vent free fireplace is typically substantially the size of a fireplace and has artificial logs. Some have even been designed with a glass front to provide the appearance of an enclosed fireplace.

The unvented heaters of the prior art are typically designed to use either natural gas or liquid propane gas as a fuel source. It is not permitted for a manufacturer to supply a conversion kit for an unvented gas heater to convert from one fuel source to another in the field. Even if such a conversion kit were permitted, as is the case with vented gas heaters, to change fuel source gas type on a heater in the field, requires the installer to change the regulator, pilot orifice and burner orifice for the alternate gas type.

SUMMARY OF THE DISCLOSURE

A dual fuel gas burner is provided for use in a vent free heater. Embodiments of the dual fuel vent free gas burner can be used in free standing heaters, wall mount heaters, gas fireplaces, or other vent free heaters as is known in the art. A dual fuel vent free gas heater provides convective and/or radiant heat preferably to an indoor environment. The heater may be designed to use natural convective air currents and may optionally have a fan enhancing the natural convective currents within the heater. Alternatively, a fan may be used to force the gases and/or air within the heater at desired flow patterns which may be counter to natural convective forces.

This gas heater can be operated with multiple fuels such as liquid propane or natural gas without changing or adding components or parts. In some embodiments, an installer turns a selector valve plumbed in the product gas train. This selection sends the correct gas type to the correct fuel injector and pilot burner. Preferably, all internal plumbing connections are performed at the factory rather than onsite by the user or installer.

Embodiments of the gas heater can be operated on liquid propane or natural gas by connecting the fuel supply to the correct regulator on the heater. The installer or user then turns a selector valve, in selected embodiments, plumbed in the product gas train. This selection sends the correct gas type to the correct injector and pilot burner for the supply gas. Optionally, an oxygen detection system is incorporated within the heater. Advantageously, the heater is thermostatically controlled.

According to one implementation a dual fuel heater is provided comprising: a first oxygen depletion sensor adapted for a first fuel, a second oxygen depletion sensor adapted for a second fuel, a main burner adapted for both the first fuel and the second fuel, a single pressure regulator having a single fuel inlet and a single fuel outlet and adapted to regulate the pressure at the single fuel outlet of the first fuel delivered at the single fuel inlet at a first pressure or the second fuel delivered at the single fuel inlet at a second pressure, a control valve having a first inlet fluid communicable with a first outlet and a second outlet, the first inlet coupled to the single fuel outlet of the single pressure regulator, the control valve adapted to control the flow of fuel to the first and second oxygen depletion sensors through the first outlet and to control the flow of fuel to the main burner through the second outlet, a selector valve comprising a first inlet fluid communicable with a first outlet and a second inlet fluid communicable with a second outlet, the first inlet of the selector valve coupled with the first outlet of the control valve by a first conduit, the second inlet of the selector valve coupled with the second outlet of the control valve by a second conduit, the first outlet of the selector valve in fluid communication with the first oxygen depletion sensor, the second outlet of the selector valve in fluid communication with the main burner, the selector valve comprising a regulating organ adapted to transition between a first selector position and a second selector position, in the first selector position the regulating organ permitting the flow of fuel between the second inlet and second outlet of the selector valve through a first orifice in the regulating organ calibrated for the first fuel and also permitting the flow of fuel between the first inlet and first outlet of the selector valve, in the second selector position the regulating organ permitting the flow of fuel between the second inlet and second outlet of the selector valve through a second orifice in the regulating organ calibrated for the second fuel and also preventing the flow of fuel between the first inlet and first outlet of the selector valve, the second oxygen depletion sensor in fluid communication with the first conduit that couples the first outlet of the control valve with the first inlet of the selector valve.

In one implementation the first fuel is natural gas and the second fuel is liquefied petroleum gas, while in another implementation the first fuel is natural gas and the second fuel is butane.

BRIEF DESCRIPTION OF THE DRAWINGS

FIG. 1 is a front perspective view of an embodiment of a dual fuel vent free heater showing heater components thereof assembled within a housing;

3

FIG. 2 is a cut-away view of the dual fuel vent free heater of FIG. 1 showing an oxygen detection system;

FIG. 3 is a schematic view of the dual fuel vent free heater of FIG. 1 showing flow connection of component parts;

FIG. 4 is a schematic view of a dual fuel vent free heater having a single multiuse injector and a thermal switch;

FIG. 5 is a schematic view of a dual fuel vent free heater having a dual burner configuration;

FIG. 6 is a schematic view of a dual fuel vent free heater having a dual burner and dual thermostatic control configuration;

FIG. 7 is a schematic view of a dual fuel vent free heater having a multi-positional manual control valve, a thermal switch, and a thermostatic control valve;

FIG. 8, which includes and is defined by sub-part FIGS. 8A and 8B, provides blow-up views of the multi-positional manual control valve of FIG. 7;

FIG. 9 is a schematic view of a dual fuel vent free heater having a multi-positional manual control valve, a thermal switch, a thermostatic control valve, and pilot burners aligned on a similar side of a burner;

FIG. 10 is schematic view of the dual fuel vent free heater having a first burner, a second burner, and a cross-over burner for use in a vent free fireplace unit;

FIG. 11 is a schematic view of a dual fuel vent free heater having a multi-positional manual control valve directly controlling the flow of fuel into the heater;

FIG. 12 is a schematic view of a dual fuel vent free heater having a multi-positional manual control valve, a thermal switch, a thermostatic control valve, a single fuel injector, linkage, and pilot burners aligned on opposite sides of a burner;

FIG. 13 is an isometric view of the multi-positional manual control valve of FIG. 12;

FIG. 14 is a schematic view of a dual fuel vent free heater having a multi-positional manual control valve, a thermal switch, a thermostatic control, a single fuel injector, and a pilot flame burner equipped for use with two fuels; and

FIG. 15 is an isometric view of the pilot flame burner equipped for use with two fuels of FIG. 14.

FIG. 16 is a schematic view of a dual fuel vent free heater according to another implementation.

FIG. 17 is a schematic view of a dual fuel vent free heater according to another implementation.

DETAILED DESCRIPTION

The following description describes embodiments of a dual fuel vent free heater. In the following description, numerous specific details and options are set forth in order to provide a more thorough understanding of the present invention. It will be appreciated, however, by one skilled in the art that the invention may be practiced without such specific details or optional components and that such descriptions are merely for convenience and that such are selected solely for the purpose of illustrating the invention. As such, reference to the figures showing embodiments of the present invention is made to describe the invention and not to limit the scope of the disclosure and claims herein.

FIGS. 1, 2 and 3 show dual fuel vent free heater 100. FIG. 1 shows the component parts of dual fuel vent free heater 100 in a housing 180 and FIG. 3 shows the flow diagram of heater 100. Dual fuel vent free gas heater 100 comprises a gas burner 132 having a plurality of gas outlet ports 155 (shown in FIG. 2) in an upper surface thereof. It is to be understood that outlet ports 155 may be in a side and/or lower surface of gas burner 132 and gas burner 132 may be

4

situated vertically or angled within housing 180 and still be within the scope of this invention. Gas outlet ports 155 are in flow communication with pilot flame burners 120 and 122. Brackets 139 hold pilot flame burners 120 and 122, piezometric igniters 157 and 159, and temperature sensors 152a and 154a proximate burner 132. Piezometric igniters 157 and 159 are adjacent to pilot flame burners 122 and 120 respectively. Fuel injectors 126 and 128 are in flow communication with the interior portion of gas burner 132. Bracket 124 holds fuel injectors 126 and 128 at an injection angle with respect to a longitudinal axis of gas burner 132 other than 0°. Injectors 126 and 128 are non-concentrically aligned with a burner venturi within burner 132. Bracket 124 controls the angle of each injector with the axis of the burner or venturi. This angle may be varied depending on the size of the burner. Optionally, an oversized venturi may accommodate non-concentric injectors 126 and 128. Preferably, bracket 124 has threaded apertures for accommodation of injectors having a threaded outer annular surface. Preferably, the injection angle of each injector is of the same magnitude. Fuel supply lines 134 and 136 are in flow communication with fuel injectors 126 and 128 respectively. Fuel supply line 134 and injector 126 have a composition and configuration for transporting a fuel such as natural gas or liquid propane at a desired flow rate and fuel supply line 136 and injector 128 have a composition and configuration for transporting a different fuel such as the other of natural gas or liquid propane at a desired flow rate.

FIG. 2 is a cutaway portion of dual fuel vent free heater 100 showing an oxygen detection system. Oxygen detection control system 131, shown schematically in FIG. 3, is in electrical communication with temperature sensors 152a and 154a and thermostatic control 130 wherein thermostatic control 130 has valves controlling the flow of fuels to injectors 126 and 128 and pilot flame burners 120 and 122. The term "thermostatic control" is used broadly throughout this specification and is not limited to controls having a temperature sensing component. Rather, the term encompasses a broad range of controls that may be implementable into a dual fuel heater, including, but not limited to, controls having a temperature sensing component as well as controls that are manually or electrically activated. Oxygen detection control system 131 sends an electrical signal to thermostatic control 130 directing thermostatic control 130 to close the valves shutting off the flow of fuel when a temperature sensor 152a or 154a indicates a temperature less than a control temperature thereby indicating a low oxygen level condition.

Dual fuel vent free gas heater 100 comprises two regulators 112 and 114 in flow communication with "T" connector 110 via fuel lines 148 and 150 respectively. Fuel line 146 extends from "T" connector 110 to thermostatic control 130. Pilot line 144 leads from thermostatic control 130 to pilot control valve 118. Injector line 142 leads from thermostatic control 130 to injector control valve 116. Fuel lines 138 and 140 lead from pilot control valve 118 to pilot flame burners 122 and 120 respectively. Fuel lines 136 and 134 lead from injector control valve 116 to injectors 126 and 128 respectively. Control valves 118 and 116 are manually adjusted for the fuel type being connected to regulator 112 or 114. Typically control valves 118 and 116 each have a setting for natural gas and a setting for liquid propane gas and are adjusted according to the fuel connected to regulator 112 or 114.

FIG. 4 shows a schematic view of dual fuel vent free heater 400 having a single burner 132 and a thermal switch 458. Gas burner 132 has a plurality of gas outlet ports. Fuel

5

injector 426 is in flow communication with fuel supply line 134 and an interior of gas burner 132. Fuel injector 426 has a manual control valve therein for controlling the flow of a fuel to burner 132. Injector 426 has at least two settings for adjustment to alternate between at least two different fuels being fed from regulator 112 or regulator 114 through fuel supply line 134. Fuel supply line 134 is in flow communication with thermostatic control 130. Fuel line 140 is in flow communication with thermostatic control 130 and pilot burner 120 and has regulator 456 inline therewith. Regulators 114 and 112 each have back flow prevention systems or a plug 411 allowing a single fuel tank to be connected to either regulator leaving the other regulator without a fuel source. Regulators 112 and 114 are each in flow communication with a "T" connector via fuel lines 148 and 150 respectively. Fuel inlet line 146 extends from the "T" connector and feeds into thermostatic control 130. Thermal switch 458 is in electrical communication with thermostatic control 130 and temperature sensor 154a. Temperature sensor 154a is in proximity to pilot burner 120 and primary burner 132 as shown. Thermal switch 458 sends an electrical signal to thermostatic control 130 shutting off fuel flow to fuel supply line 134 and pilot burner supply line 140 in the event that an incorrect setting is made with injector 426 with respect to the fuel being fed to regulator 112 or 114 by measuring a high temperature condition via temperature sensor 154a at burner 132.

In an alternative embodiment thermal switch 458 is still in electrical communication with thermostatic control 130 and temperature sensor 154a, but does not measure a high temperature condition via temperature sensor 154a. Rather, thermal switch 458 has internal temperature sensing and is appropriately positioned in dual fuel vent free heater 400 to measure a high temperature condition. For example, thermal switch 458 may be a normally closed switch that is opened upon expansion of one or more metals, such as a snap disc, caused by a set temperature being reached. In this alternative embodiment, communication between temperature sensor 154a and thermostatic control 130 is ceased when the wrong fuel type is introduced and a high temperature condition is measured via thermal switch 458, causing the supply of gas to be shut off by thermostatic control 130.

FIG. 5 shows dual fuel vent free heater 500 having a dual burner configuration. Two regulators 112 and 114 are in flow communication with a "T" connector via fuel lines 148 and 150 respectively. Fuel line 146 extends from the "T" connector to thermostatic control 130. Pilot burner supply lines 138 and 140 lead from thermostatic control 130 to pilot flame burners 122 and 120 respectively. Fuel injector lines 134 and 136 lead from thermostatic control 130 to injectors 126 and 128 respectively. Burner 132a has first pilot flame burner 122 proximate gas outlet apertures therein and injector 126 proximate an axial opening. Burner 132b has pilot flame burner 120 proximate gas outlet apertures and injector 128 proximate an axial opening therein.

FIG. 6 is a schematic view of a dual fuel vent free heater 600 having a dual burner and dual thermostatic control configuration. Regulator 112 is in flow communication with thermostatic control 130a via fuel line 148. Regulator 114 is in flow communication with thermostatic control 130b via fuel line 150. Pilot supply line 140 leads from thermostatic control 130a to pilot flame burner 120 and pilot supply line 138 leads from thermostatic control 130b to pilot flame burner 122. Injector supply line 134 leads from thermostatic control 130a to fuel injector 126. Injector supply line 136 leads from thermostatic control 130b to fuel injector 128. Burner 132a has pilot flame burner 120 proximate gas outlet

6

apertures and fuel injector 126 proximate an axial opening. Burner 132b has pilot flame burner 122 proximate gas outlet apertures and fuel injector 128 proximate an axial opening therein.

FIG. 7 shows a schematic view of dual fuel vent free heater 700 having a multi-positional manual control valve 800. Regulators 112 and 114 are in flow communication with a "T" connector via fuel lines 148 and 150 respectively. Fuel line 146 extends from the "T" connector to thermostatic control 130. Pilot line 142 and injector line 144 lead from thermostatic control 130 to multi-positional manual control valve 800. Multi-positional manual control valve 800 directs flow from pilot line 142 and injector line 144 to pilot supply line 140 and injector supply line 136, or pilot supply line 138 and injector supply line 134, or blocks the flow from pilot line 142 and injector line 144. Burner 132 has injectors 126 and 128 held at an angle to the burner axis in proximity to the burner opening with bracket 124. Pilot burners 120 and 122 are proximate the outer surface of burner 132 and are in flow communication with pilot supply line 140 and 138 respectively. Thermal switch 158 is in electrical communication with T/C block 756. T/C block 756 is in electrical communication with a temperature sensor 152a, 154a proximate each pilot burner 120 and 122 and primary burner 132, via T/C lines 154 and 152, and thermostatic control 130. In the event an incorrect setting is made with respect to the fuel being fed to the correct injector and pilot burner, thermal switch 158 or thermostatic control 130 shuts off the flow of gas to heater 700 by reading of a high temperature condition near burner 132.

FIG. 8 which includes and is defined by sub-part FIGS. 8A and 8B shows a blow-up view of multi-positional manual control valve 800. Multi-positional manual control valve 800 comprises a control block 804 and a control cylinder 802. Control block 804 has a cylindrical aperture 850 extending from a front surface to a rear surface. The front surface of control 800 has fuel selection and cut off indicators LP, NG, and OFF. Three fuel injector apertures 820, 824 and 830 extend from cylindrical aperture 850 at about 90° intervals to a left side, top, and right side of control block 804. A pilot aperture is axially aligned about cylindrical aperture 850 with each fuel injector aperture, pilot aperture 822 is axial aligned with injector aperture 820, pilot aperture 826 is axial aligned with injector aperture 824, and pilot aperture 828 is axial aligned with injector aperture 830. Control cylinder 802 has an outer circumference proximate the circumference of cylindrical aperture 850 in control block 804 wherein control cylinder 802 is closely received within. Control cylinder 802 has "L" shaped flow through fuel injector aperture 812 and an axially aligned "L" shaped flow through pilot aperture 814. Control cylinder 802 has a first, second, and third, position within the cylindrical aperture in control block 804. The front surface of control cylinder 802 has a selection arrow pointing to an appropriate indicator on the front surface of control block 804. At a first position, fuel injector aperture 820 and pilot aperture 822 are in flow communication with fuel injector aperture 824 and pilot aperture 826. At a second position, as shown in FIG. 8B, fuel injector aperture 824 and pilot aperture 826 are in flow communication with fuel injector aperture 830 and pilot aperture 828. At the third position, one end of the "L" shaped flow through fuel injector aperture 812 and axially aligned "L" shaped flow through pilot aperture 814 are blocked by the wall of cylindrical aperture 850 in control block 804 cutting off the flow of fuel.

FIG. 9 shows a schematic view of dual fuel vent free heater 900. Dual fuel vent free heater 900 comprises two

regulators **112** and **114** in flow communication with a “T” connector via fuel lines **148** and **150**. Fuel line **146** extends from the “T” connector to thermostatic control **130**. A pilot line **142** and an injector line **144** lead from thermostatic control **130** to multi-positional manual control valve **800**. Multi-positional manual control valve **800** has a first, second, and third control position as indicated with LP, NG, and OFF. The first control position creates a flow communication between the pilot line **144** and injector line **142** leading from thermostatic control **130** with pilot flame burner **120** and injector **128** through pilot feed line **140** and injector feed line **136** respectively. The second control position creates a flow communication between pilot line **144** and injector line **142** leading from thermostatic control **130** with pilot flame burner **122** and injector **126** respectively. The third position cuts off fuel flow from pilot line **144** and injector line **142** leading from thermostatic control **130**. Thermal switch **935** is in electrical communication with a temperature sensor proximate pilot flame burners **120** and **122** and primary burner **132** as shown via electrical connectors **154** and **152** respectively through thermo control block (T/C block) **933**. Thermal switch **935** sends a shut off signal to thermostatic control **130** when a first set temperature is exceeded in burner **132** indicating a wrong fuel setting and cutting off the flow of fuel to heater **900**. Embodiments incorporating this safety shut-off feature and the safety shut-off feature shown in FIG. 2 and previously described, shutting off fuel flow to the gas heater in the event a set temperature is exceeded, provide complete fuel shut-off functionality.

FIG. 16 shows a schematic view of a dual fuel vent free heater **1500**. Dual fuel vent free heater **1500** comprises a single pressure regulator **115** in flow communication with thermostatic control **130** via fuel line **146**. A pilot line **144** and an injector line **142** lead from thermostatic control **130** to multi-positional manual control valve **910**. Multi-positional manual control valve **910** has at least first and second control position as indicated with P1 and P2. The first control position P1 creates a flow communication between the pilot line **144** and injector line **142** leading from thermostatic control **130** with pilot flame burner **122** and injector **126** through pilot feed line **138** and injector feed line **134**, respectively. The second control position P2 creates a flow communication between injector line **142** leading from thermostatic control **130** with injector **128** through injector feed line **136**. When in the second control position P2 flow communication between pilot line **144** and pilot flame burner **122** is prevented. When the selector valve **910** is in both the first control position P1 and the second control position P2 flow communication between the thermostatic control valve **130** and pilot flame burner **120** is maintained through pilot feed line **140**. In one implementation thermal switch **935** is in electrical communication with a temperature sensor proximate pilot flame burners **120** and **122** and primary burner **132** as shown via electrical connectors **154** and **152**, respectively, through thermo control block (T/C block) **933**. Thermal switch **935** sends a shut off signal to thermostatic control **130** when a first set temperature is exceeded in burner **132** indicating a wrong fuel setting and cutting off the flow of fuel to heater **1500**. Embodiments incorporating this safety shut-off feature and the safety shut-off feature shown in FIG. 2 and previously described, shutting off fuel flow to the gas heater in the event a set temperature is exceeded, provide complete fuel shut-off functionality.

In one implementation the single pressure regulator **115** has a single fuel inlet and a single fuel outlet and is adapted to regulate the pressure at the single fuel outlet of a first fuel

delivered at the single fuel inlet at a first pressure or a second fuel delivered at the single fuel inlet at a second pressure. In one implementation the pressure regulator is equipped with a selector **117** that is moveable between at least first and second positions. When in the first position the pressure regulator **115** is adapted to regulate the pressure at the single fuel outlet of the first fuel and when in the second position the pressure regulator **115** is adapted to regulate the pressure at the single fuel outlet of the second fuel. In one implementation the first fuel is natural gas and the second fuel is liquefied propane gas, while in another implementation the first fuel is natural gas and the second fuel is butane. In one implementation the pressure regulator **115** comprises a dual gas pressure regulator like that disclosed in U.S. Pat. No. 7,600,529 which is incorporated herein by reference in its entirety.

As previously discussed, the pilot flame burners **120** and **122** each form a part of an oxygen depletion sensor that include temperature sensors **152a** and **154a**, respectively. Each of the pilot flame burners **120** and **122** is also associated with a piezometric igniter **157** and **159**, respectively. According to one implementation, pilot flame burner **122** comprises a first injector at an inlet thereof adapted for the introduction of natural gas while pilot flame burner **120** comprises a second injector at an inlet thereof adapted for the introduction of liquefied propane gas. According to another implementation, pilot flame burner **122** comprises a first injector at an inlet thereof adapted for the introduction of natural gas while pilot flame burner **120** comprises a second injector at an inlet thereof adapted for the introduction of butane. In one implementation, because pilot flame burner **120** is situated to receive a fuel whenever a fuel flow is established through the thermostatic control valve **130**, piezometric igniter **157** is activated each time piezometric igniter **159** is activated.

FIG. 17 shows a schematic view of a dual fuel vent free heater **1600**. Dual fuel vent free heater **1600** comprises a single pressure regulator **115** in flow communication with thermostatic control **130** via fuel line **146**. A pilot line **144** and an injector line **142** lead from thermostatic control **130** to multi-positional manual control valve **920**. Multi-positional manual control valve **920** has at least first and second control position as indicated with P1 and P2. The first control position P1 creates a flow communication between the pilot line **144** and injector line **142** leading from thermostatic control **130** with pilot flame burner **122** and injector **127** through pilot feed line **138** and injector feed line **134**, respectively. The second control position P2 creates a flow communication between injector line **142** leading from thermostatic control **130** with injector **127** through injector feed line **134**. When in the second control position P2 flow communication between pilot line **144** and pilot flame burner **122** is prevented. When the selector valve **920** is in both the first control position P1 and the second control position P2 flow communication between the thermostatic control valve **130** and pilot flame burner **120** is maintained through pilot feed line **140**.

In one implementation the manual control valve **920** comprises a regulating organ having at least a first orifice and a second orifice, the first orifice calibrated for the delivery of a first fuel (e.g., natural gas) to the main burner fuel injector **127**, the second orifice calibrated for the delivery of a second fuel (e.g., liquefied petroleum gas, butane, etc.) to fuel injector **127**. In such an implementation when the manual control valve **920** is in the first control position P1, flow communication between fuel lines **142** and **134** is established through the first orifice and when the

manual control valve **920** is in the first control position P1, flow communication between fuel lines **142** and **134** is established through the second orifice.

In one implementation thermal switch **935** is in electrical communication with a temperature sensor proximate pilot flame burners **120** and **122** and primary burner **132** as shown via electrical connectors **154** and **152**, respectively, through thermo control block (T/C block) **933**. Thermal switch **935** sends a shut off signal to thermostatic control **130** when a first set temperature is exceeded in burner **132** indicating a wrong fuel setting and cutting off the flow of fuel to heater **1600**. Embodiments incorporating this safety shut-off feature and the safety shut-off feature shown in FIG. 2 and previously described, shutting off fuel flow to the gas heater in the event a set temperature is exceeded, provide complete fuel shut-off functionality.

In one implementation the single pressure regulator **115** has a single fuel inlet and a single fuel outlet and is adapted to regulate the pressure at the single fuel outlet of a first fuel delivered at the single fuel inlet at a first pressure or a second fuel delivered at the single fuel inlet at a second pressure. In one implementation the pressure regulator is equipped with a selector **117** that is moveable between at least first and second positions. When in the first position the pressure regulator is adapted to regulate the pressure at the single fuel outlet of the first fuel and when in the second position the pressure regulator is adapted to regulate the pressure at the single fuel outlet of the second fuel. In one implementation the first fuel is natural gas and the second fuel is liquefied propane gas, while in another implementation the first fuel is natural gas and the second fuel is butane. In one implementation the pressure regulator **115** comprises a dual gas pressure regulator similar to that disclosed in U.S. Pat. No. 7,600,529 which is incorporated herein by reference in its entirety.

As previously discussed, the pilot flame burners **120** and **122** each form a part of an oxygen depletion sensor that include temperature sensors **152a** and **154a**, respectively. Each of the pilot flame burners **120** and **122** is also associated with a piezometric igniter **157** and **159**, respectively. According to one implementation, pilot flame burner **122** comprises a first injector at an inlet thereof adapted for the introduction of natural gas while pilot flame burner **120** comprises a second injector at an inlet thereof adapted for the introduction of liquefied propane gas. According to another implementation, pilot flame burner **122** comprises a first injector at an inlet thereof adapted for the introduction of natural gas while pilot flame burner **120** comprises a second injector at an inlet thereof adapted for the introduction of butane. Because pilot flame burner **120** is situated to receive a fuel whenever a fuel flow is established through the thermostatic control valve **130**, piezometric igniter **157** is activated each time piezometric igniter **159** is activated.

FIG. 10 shows a schematic view of dual fuel vent free heater **1000** having burner **132a**, **132b**, and cross-over burner **171**. Such a configuration provides a blue flame burner and a yellow flame burner as is often desirable in a vent free fireplace heater. The configuration of heater **1000** is similar to the configuration of heater **900** with the addition of burners **132b**, cross-over burner **171**, two fuel line "T" connectors, and fuel injectors **126b** and **128b**. Crossover burner **171** is in flow communication with burners **132a** and **132b**. Burner **132b** has fuel injectors **126b** and **128b** held by bracket **124b** proximate an axial end and is situated substantially parallel burner **132a**. Fuel supply line **134b** feeds injector **126b** with a "T" connector in flow communication with fuel supply line **134a**. Fuel supply line **136b** feeds

injector **128b** with a "T" connector in flow communication with fuel supply line **136a**. The statement: "Two burners or parts of burners that are in flow communication with each other" implies either that there is an opening or a connection between the two burners that allows a gas to flow from one to the other, or that some of the openings in each burner are in close proximity with each other to allow the burning gasses from one burner to ignite the gasses emanating from the other.

FIG. 11 is a schematic view of dual fuel vent free heater **1100** having a multi-positional manual control valve **800** directly controlling the flow of fuel into heater **1100**. The configuration of heater **1100** is similar to that of heater **900** but does not have thermostatic control **130**. Rather, fuel from either regulator **112** or regulator **114** is fed through fuel line **148** or **150**. Fuel lines **148** and **150** "T" into pilot line **142** and injector line **144** which lead directly to multi-positional manual control valve **800**. Therefore, the amount of heat produced by heater **1100** is manually controlled with multi-positional manual control valve **800** without any thermostatic control.

FIG. 12 shows a schematic view of dual fuel vent free heater **1200** having a multi-positional manual control valve **860**. The word "manual" in "multi-positional manual control valve" is not meant to limit multi-positional manual control valve **860** or other control valves mentioned herein to being actuated manually. Rather, as understood in the art, multi-positional manual control valve may encompass a number of control valves, such as those that are electronically or otherwise actuated. Regulators **112** and **114** are in flow communication with a "T" connector to thermostatic control **130** via fuel lines **148** and **150** respectively. Fuel line **146** extends from "T" connector to thermostatic control **130**. Pilot line **142** and injector line **144** lead from thermostatic control **130** to multi-positional manual control valve **860**. Multi-positional manual control valve **860** preferably has fuel selection indicators LP and NG that correspond to two different positions of multi-positional manual control valve **860**. Multi-positional manual control valve **860** directs flow from pilot line **142** to pilot supply line **140** or from pilot line **142** to pilot supply line **138** dependent upon whether the LP or NG position is selected. Additionally, multi-positional manual control valve **860** directs flow from injector line **144** to injector supply line **137** when the NG position is selected, while causing the flow from injector line **144** to injector supply line **137** to be restricted when LP is selected. Flow is restricted by decreasing the size of at least a portion of the orifice internal to multi-positional manual control valve **860** through which flow from injector line **144** to injector supply line **137** proceeds when LP is selected. Multi-positional manual control valve **860** may also be provided with a cut off indicator OFF that corresponds to an optional additional position of multi-positional manual control valve **860**. Such an indicator would block the flow from injector line **140** and pilot line **142** if the OFF position is selected. However, it is preferred that thermostatic control **130**, instead of multi-positional manual control valve **860**, be provided with controls for turning dual fuel vent free heater **1200** off.

Pilot burners **120** and **122** are proximate the outer surface of burner **132** and are in flow communication with pilot supply lines **140** and **138** respectively. Burner **132** has a single injector **427** held in proximity to the burner opening and preferably supported by bracket **125**. The flow of fuel through injector **427** is controlled by multi-positional manual control valve **860** when the appropriate fuel selection is made and no separate adjustment to fuel injector **427** is necessary when selecting a different fuel. Piezometric

igniters **157** and **159** are adjacent to pilot flame burners **122** and **120**, respectively. Temperature sensors **152a** and **154a** are proximate to pilot flame burners **122** and **120** respectively and are in electrical communication with thermal switch **558**, which is in electrical communication with thermostatic control **130**.

Temperature sensors **152a** and **154a** are positioned such that when their respective pilot flame burners are lit with a safe oxygen level present, they will be in contact with or substantially close to the pilot flame to be sufficiently heated and resultantly supply a predetermined voltage through thermal switch **558**, if it is in the closed position, to thermostatic control **130**. If this voltage is not supplied, the supply of gas to burner **132** and pilot flame burner **120** and **122** will be shut off by thermostatic control **130**. This predetermined voltage will not be supplied when an unsafe oxygen level is present, since the pilot flame will no longer be substantially close to its respective temperature sensor **152a** or **154a**, causing temperature sensor **152a** or **154a** to be insufficiently heated and supply a voltage less than the predetermined voltage. In this embodiment, thermal switch **558** is preferably a normally closed switch with internal temperature sensing and is positioned in dual fuel vent free heater **1200** such that under normal heater operating conditions, it will reach a temperature that is under its set point. However, if the wrong gas type is introduced and burned in burner **132**, it will cause thermal switch **558** to heat to a temperature at or above its set point and be in the open position. This will break the communication between temperature sensors **152a** and **154a** and thermostatic control **130**, causing the supply of gas to injector **427** and pilot flame burners **120** and **122** to be shut off by thermostatic control **130**. The wrong gas type may be introduced in burner **132** by, among other things, feeding the wrong fuel to regulator **112** or **114**, malfunction of multi-positional manual control valve **860**, or by an incorrect setting on a fuel injector with a manual control valve.

Dual fuel vent free heater **1200** of FIG. **12** is also shown with a linkage **880** that interacts with an air shutter **133** and multi-positional manual control valve **860**. Linkage **880** adjusts the position of air shutter **133** based upon the selected position of multi-positional manual control valve **860**. Air shutter **133** is located proximal to fuel injector **427** and forms part of, or is attached to, or is in close proximity to burner **132**. Adjustment of air shutter **133** allows varying amounts of air to be received through an opening in burner **132** for ideal combustion of the selected fuel. For example, in some embodiments linkage **880** could cause air shutter **133** to completely cover the opening in burner **132** when NG is selected by multi-positional manual control valve **860** and to allow the opening in burner **132** to be completely exposed when LP is selected. Dual fuel vent free heater **1200** may also be provided with a linkage (not shown) that blocks the connection to either regulator **112** or **114** dependent upon which fuel is selected by multi-positional manual control valve **860**. The linkage would prevent connection to the regulator corresponding with the fuel that is not selected, preferably by blocking or obstructing the input to the given regulator.

Turning to FIG. **13**, an isometric view of a preferred embodiment of multi-positional manual control valve **860** is shown. Multi-positional manual control valve **860** has a pilot line aperture **862**, a LP pilot supply line aperture **864**, a NG pilot supply line aperture **866**, a fuel injector line aperture **870**, and a fuel injector supply line aperture **872**. Multi-positional manual control valve **860** also has an extension **882** which extends exteriorly and allows for

attachment of a knob (not shown) for selection between LP and NG through rotational adjustment of internal orifices. In a first position, pilot line aperture **862** is in flow communication with LP pilot supply line aperture **864** and fuel injector line aperture **870** is in flow communication with fuel injector supply line aperture **872** and at least a portion of the internal orifice is restricted that communicates input from injector line aperture **870** to fuel injector supply line aperture **872**. In a second position, pilot line aperture **862** is in flow communication with NG pilot supply line aperture **866** and fuel injector line aperture **870** is in flow communication with fuel injector supply line aperture **872**.

FIG. **14** shows a schematic view of dual fuel vent free heater **1400**. Dual fuel vent free heater **1400** is similar to dual fuel vent free heater **1200**, except that it is shown without linkage **880** or air shutter **133** and has a single piezometric igniter **159**, a single temperature sensor **154a**, and a pilot flame burner equipped for use with two fuels **220**. Single temperature sensor **154a** preferably interacts with thermostatic control **130** to provide for an oxygen detection system as previously described and additionally preferably interacts with thermal switch **558** to provide for a complete safety shutoff system as previously described.

Turning to FIG. **15**, pilot flame burner equipped for use with two fuels **220** has a first fuel input orifice **222**, a second fuel input orifice **224**, and a single fuel nozzle **226**. First fuel input orifice **222** and second fuel input orifice **224** are shown in FIG. **14** in communication with pilot supply lines **140** and **138** respectively. Since multi-positional manual control valve **860** merely redirects flow from pilot line **142** to pilot supply line **138** or pilot supply line **140**, the initial orifice size of first fuel input orifice **222** and second fuel input orifice **224** are preferably substantially the same. However, at some point before the merger of first fuel input orifice **222** and second fuel input orifice **224**, the orifice size of first fuel input orifice **222** is restricted more than the orifice size of second fuel input orifice **224**.

In a preferred embodiment, where multi-positional manual control valve **860** is adjustable to direct flow from pilot line **142** to pilot supply line **138** if natural gas is being used and adjustable to direct flow from pilot line **142** to pilot supply line **140** if liquid propane is being used, first fuel input orifice **222** is preferably restricted to a diameter of approximately 0.30 mm at some point before the merger of first fuel input orifice **222** and second fuel input orifice **224**, whereas the minimum orifice size of second fuel input orifice **224** is approximately 0.42 mm. Of course, when natural gas and liquid propane are the two fuels being used the actual orifice sizes may vary to some degree while still allowing for a pilot flame burner with a single fuel nozzle that can be used with two fuels. Moreover, when other fuels are being used the actual orifice sizes may vary to an even larger degree. Restricting the orifice size of first fuel input orifice **222** more than the orifice size of second fuel input orifice **224** prior to the merger of the two, causes fuel volume to be restricted and allows single fuel nozzle **226** to function with either of two fuels. Moreover, the design and placement of pilot flame burner equipped for use with two fuels **220** enables fuel volume to be properly restricted without substantially affecting fuel velocity. Therefore, a single oxygen detection system having an igniter and at least one temperature sensor proximate a single fuel nozzle can be implemented into a number of dual fuel vent free heaters using pilot flame burner equipped for use with two fuels **220**.

U.S. Pat. No. 5,807,098 teaches several aspects of a gas heater and a gas heater oxygen detection system and is incorporated by reference into the present document in its

13

entirety. Using teachings from U.S. Pat. No. 5,807,098 it is clear, among other things, how more than one temperature sensor may be used with a dual fuel heater having a pilot flame burner equipped for use with two fuels 220, or other dual fuel heaters taught herein, to provide for added functionality. Moreover, it is clear that input could be diverted to either pilot line 142 or pilot supply line 138 and resultantly first fuel input orifice 222 and second fuel input orifice 224 of pilot flame burner equipped for use with two fuels 220 through use of other valves besides multi-positional manual control valve 860.

What is claimed is:

1. A dual fuel heater comprising: a first oxygen depletion sensor adapted for a first fuel, a second oxygen depletion sensor adapted for a second fuel, a main burner adapted for both the first fuel and the second fuel,

a control valve having a first inlet fluid communicable with a first outlet and a second outlet, the first inlet configured to receive the first fuel and the second fuel, the control valve adapted to control the flow of fuel to the first and second oxygen depletion sensors through the first outlet and to control the flow of fuel to the main burner through the second outlet,

a selector valve comprising [a first] an inlet fluid communicable with [a first] an outlet [and a second inlet fluid communicable with a second outlet], the [first] inlet of the selector valve coupled with the first outlet of the control valve by a first conduit, [the second inlet of the selector valve coupled with the second outlet of the control valve by a second conduit.] the [first] outlet of the selector valve in fluid communication with the first oxygen depletion sensor, [the second outlet of the selector valve in fluid communication with the main burner,] the selector valve adapted to transition between a first selector position and a second selector position, in the first selector position the selector valve [adapted to permitting] *permits* the flow of the first fuel between the [second] inlet and [second] outlet of the selector valve [and also to permit the flow of the first fuel between the first inlet and first outlet of the selector valve], in the second selector position the selector valve [adapted to permitting the flow of the second fuel between the second inlet and second outlet of the selector valve and also prevent] *prevents* the flow of the [second] *first* fuel between the [first] inlet and [first] outlet of the selector valve,

the flow of the first fuel and the second fuel being permitted to the second oxygen depletion sensor via the first conduit [from a location between the first outlet of the control valve and the first inlet of the selector valve] so that the flow of the first fuel and the second fuel to the second oxygen depletion sensor is permitted regardless of whether the selector valve is in the first selector position or in the second selector position.

2. A dual fuel heater according to claim 1, wherein the first fuel is natural gas and the second fuel is liquefied petroleum gas.

3. A dual fuel heater according to claim 1, wherein the first fuel is natural gas and the second fuel is butane.

14

[4. A dual fuel heater comprising:

a first oxygen depletion sensor adapted for a first fuel,
a second oxygen depletion sensor adapted for a second fuel,

a main burner adapted for both the first fuel and the second fuel,

a control valve having a first inlet fluid communicable with a first outlet and a second outlet, the first inlet configured to receive the first fuel and the second fuel, the control valve adapted to control the flow of fuel to the first and second oxygen depletion sensors through the first outlet and to control the flow of fuel to the main burner through the second outlet,

a selector valve comprising a first inlet fluid communicable with a first outlet and a second inlet fluid communicable with a second outlet and a third outlet, the first inlet of the selector valve coupled with the first outlet of the control valve by a first conduit, the second inlet of the selector valve coupled with the second outlet of the control valve by a second conduit, the first outlet of the selector valve in fluid communication with the first oxygen depletion sensor, the second and third outlets of the selector valve in fluid communication with the main burner, the selector valve adapted to transition between a first selector position and a second selector position, in the first selector position the selector valve is adapted to permit the flow of the first fuel between the second inlet and second outlet of the selector valve and also to permit the flow of the first fuel between the first inlet and first outlet of the selector valve, in the second selector position the selector valve adapted to permit the flow of the second fuel between the second inlet and third outlet of the selector valve and also prevent the flow of the second fuel between the first inlet and first outlet of the selector valve,

the flow of the first fuel and the second fuel being permitted to the second oxygen depletion sensor via the first conduit from a location between the first outlet of the control valve and the first inlet of the selector valve so that the flow of the first fuel and the second fuel to the second oxygen depletion sensor is permitted regardless of whether the selector valve is in the first selector position or in the second selector position.]

[5. A dual fuel heater according to claim 4, wherein the first fuel is natural gas and the second fuel is liquefied petroleum gas.]

[6. A dual fuel heater according to claim 4, wherein the first fuel is natural gas and the second fuel is butane.]

7. A dual fuel heater according to claim 1, wherein the flow of the first fuel and the second fuel is permitted to the second oxygen depletion sensor via the first conduit from a location between the first outlet of the control valve and the inlet of the selector valve.

* * * * *