

O. B. KEELEY & J. FLEMING.

ROCK-DRILLING MACHINE.

No. 190,871.

Patented May 15, 1877.

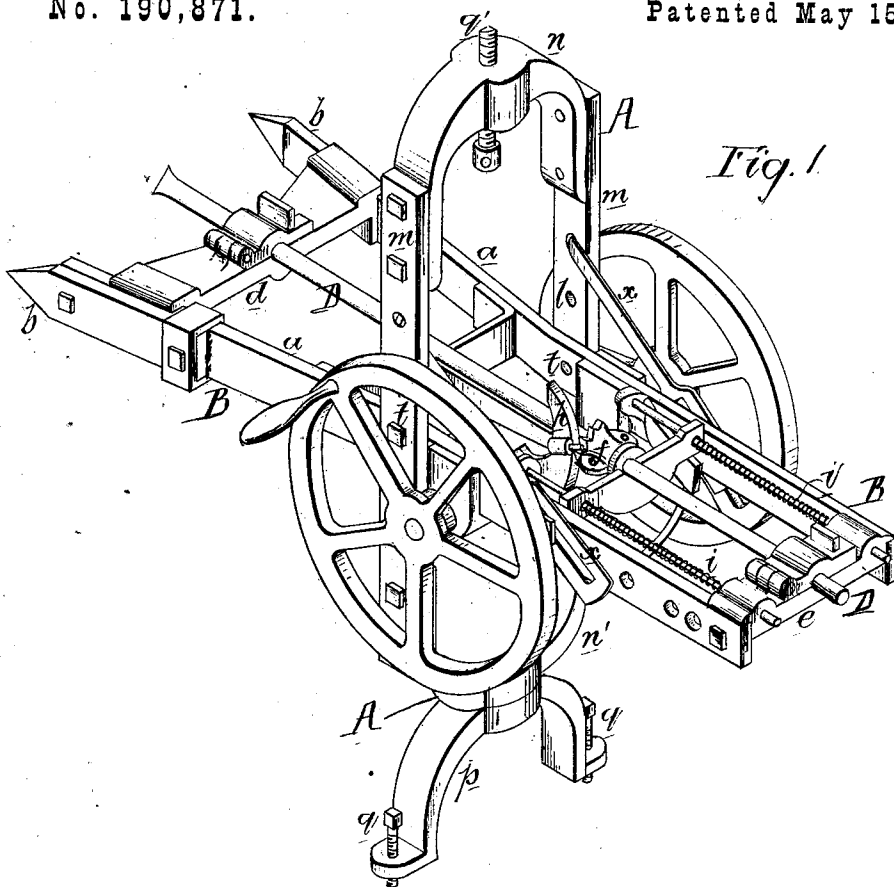

Fig. 1.

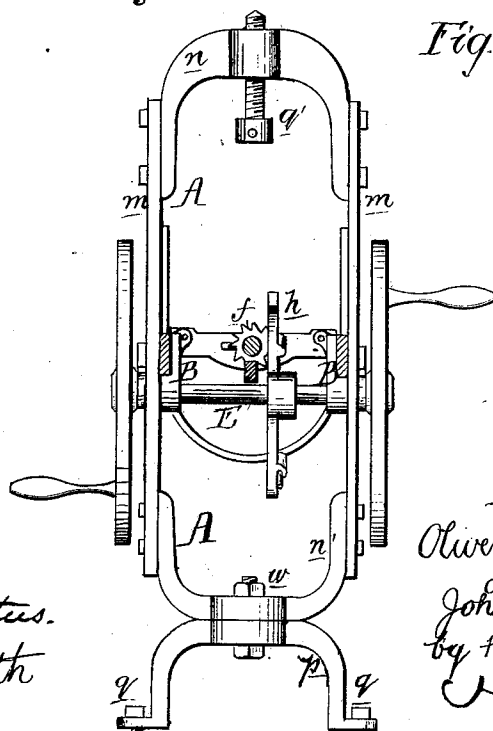

Fig. 2.

Witnesses
John K. Rupertus.
Harry Smith

Inventor:
Oliver B. Keeley
and
John Fleming
by their Attorneys
Howson and m

UNITED STATES PATENT OFFICE

OLIVER B. KEELEY AND JOHN FLEMING, OF SPRING CITY, ASSIGNORS TO
THEMSELVES AND ENOS S. SHANTZ, OF PHILADELPHIA, PA.

IMPROVEMENT IN ROCK-DRILLING MACHINES.

Specification forming part of Letters Patent No. 190,871, dated May 15, 1877; application filed
March 19, 1877.

To all whom it may concern:

Be it known that we, OLIVER B. KEELEY and JOHN FLEMING, of Spring City, Chester county, Pennsylvania, have invented a new and useful Improvement in Rock-Drilling Machines, of which the following is a specification:

Our invention relates to improvements in the rock-drilling machine for which Letters Patent, No. 142,824, were granted to W. Weaver, September 16, 1873; and the object of our invention is to so combine the said machine with a standard that increased facilities shall be afforded for the adjustment of the drill-rod to different positions.

In the accompanying drawing, Figure 1 is a perspective view of our improved rock-drilling machine, and Fig. 2 a vertical section of the same.

The machine consists of two main parts, namely, the standard A and the frame B, hinged to the said standard, and carrying the drilling-tool and mechanism for operating the same.

The latter portion of the machine is similar to that for which Letters Patent were granted to W. Weaver, September 16, 1873, and may be briefly described as follows:

The frame consists of the opposite side bars *a a*, connected together by cross-bars *d* and *e*, in which are bearings for the reciprocating and rotating drill-rod D.

A driving-shaft, E, is arranged to turn in bearings on the bars *a a* of the frame *b*, and this shaft is provided with cams or wipers *h*, which, as the shaft rotates, act against a collar on the drill-rod D, the said collar having teeth, so that the cams will turn the drill-rod while it is being moved by the cam away from the rock, springs *i i* serving to force the rod in a contrary direction when released by the cams.

The above-described parts are to be found in the said patent of Weaver, in which the frame A, however, is supported by adjustable legs in such a manner that the capacity of

the machine for boring holes in different directions, is restricted.

The standard A is composed of the opposite bars *m m*, connected together by the upper cross-piece *n*, and below by a similar cross-piece, *n'*, the latter being pivoted to the base *p* by a bolt, *w*, so as to turn laterally thereon, the said base being provided with set-screws *q* to bear on the ground.

The upper cross-piece *n* is provided with a central set-screw, *q'*, which can be adjusted to bear against any object—the roof of a tunnel, for instance.

The frame B is hinged to the standard A by pins or bolts *t t*, so that the drill-rod can be adjusted to any desired inclination in a vertical plane, while the pivot *w* and the central set-screw *q'* permit the lateral adjustment of both frame and standard, and consequently of the drill-rod, and this without disturbing the base.

In order to secure the frame B after it has been adjusted to the desired inclination, two stays, *x x*, are hinged at one end to the standard, the other ends being slotted to receive screws, which secure the said stays to the frame B.

We claim as our invention—

1. The combination of the upper portion of the standard A, and the drill-carrying frame pivoted to said upper portion, with the lower portion *p* of the standard pivoted to the upper portion at *w*, as set forth.

2. The combination of the upper portion of the standard A, carrying the drill-frame, and provided with a central-screw, *q'*, at the top, with the lower pivoted portion *p*, as specified.

In testimony whereof we have signed our names to this specification in the presence of two subscribing witnesses.

OLIVER B. KEELEY.
JOHN FLEMING.

Witnesses:

ALLEN ROGERS,
LOUIS B. AARON.