



- (51) International Patent Classification:
E21B 33/127 (2006.01) E21B 33/128 (2006.01)
- (21) International Application Number:
PCT/US2012/040719
- (22) International Filing Date:
4 June 2012 (04.06.2012)
- (25) Filing Language: English
- (26) Publication Language: English
- (30) Priority Data:
13/152,346 3 June 2011 (03.06.2011) US
- (71) Applicant (for all designated States except US): **BAKER HUGHES INCORPORATED** [US/US]; P.O. Box 4740, Houston, TX 77210-4740 (US).
- (72) Inventor; and
- (75) Inventor/Applicant (for US only): **O'MALLEY, Edward, J.** [US/US]; 720 Rutland St., Houston, TX 77007 (US).

- (81) Designated States (unless otherwise indicated, for every kind of national protection available): AE, AG, AL, AM, AO, AT, AU, AZ, BA, BB, BG, BH, BR, BW, BY, BZ, CA, CH, CL, CN, CO, CR, CU, CZ, DE, DK, DM, DO, DZ, EC, EE, EG, ES, FI, GB, GD, GE, GH, GM, GT, HN, HR, HU, ID, IL, IN, IS, JP, KE, KG, KM, KN, KP, KR, KZ, LA, LC, LK, LR, LS, LT, LU, LY, MA, MD, ME, MG, MK, MN, MW, MX, MY, MZ, NA, NG, NI, NO, NZ, OM, PE, PG, PH, PL, PT, QA, RO, RS, RU, RW, SC, SD, SE, SG, SK, SL, SM, ST, SV, SY, TH, TJ, TM, TN, TR, TT, TZ, UA, UG, US, UZ, VC, VN, ZA, ZM, ZW.
- (84) Designated States (unless otherwise indicated, for every kind of regional protection available): ARIPO (BW, GH, GM, KE, LR, LS, MW, MZ, NA, RW, SD, SL, SZ, TZ, UG, ZM, ZW), Eurasian (AM, AZ, BY, KG, KZ, RU, TJ, TM), European (AL, AT, BE, BG, CH, CY, CZ, DE, DK, EE, ES, FI, FR, GB, GR, HR, HU, IE, IS, IT, LT, LU, LV, MC, MK, MT, NL, NO, PL, PT, RO, RS, SE, SI, SK, SM, TR), OAPI (BF, BJ, CF, CG, CI, CM, GA, GN, GQ, GW, ML, MR, NE, SN, TD, TG).

[Continued on next page]

(54) Title: SEALING DEVICES FOR SEALING INNER WALL SURFACES OF A WELLBORE AND METHODS OF INSTALLING SAME IN A WELLBORE

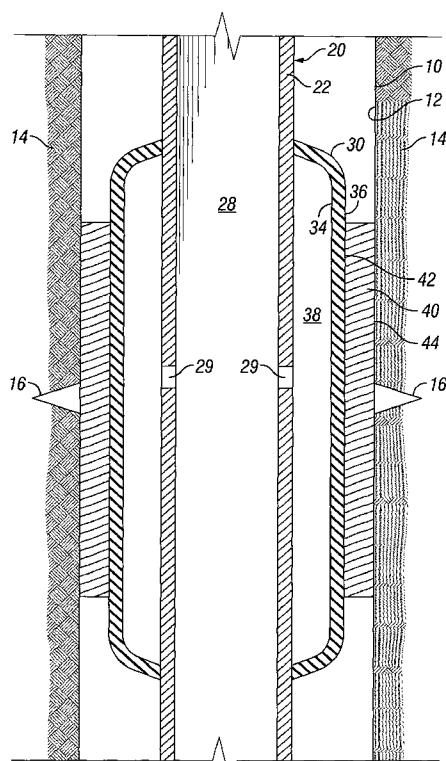

FIG. 2

(57) Abstract: Sealing devices for use in a wellbore to seal a leak path through an inner wall surface of the wellbore comprise a mandrel, an expandable element, and a shape deforming sealing element. Expansion or inflation of the expandable element moves the shape deforming sealing element from its run-in shape to its set shape. A stimulus, such as a change in temperature, acts upon the shape deforming sealing element facilitating the shape deforming sealing element changing shape. Removal of the stimulus causes the shape deforming sealing element to remain in the set shape. Thereafter, the mandrel and expandable element can be removed to leave only the shape deforming sealing element within the wellbore to seal the leak path.

WO 2012/167240 A2

Declarations under Rule 4.17:

- *as to applicant's entitlement to apply for and be granted a patent (Rule 4.17(ii))*
- *as to the applicant's entitlement to claim the priority of the earlier application (Rule 4.17(iii))*

Published:

- *without international search report and to be republished upon receipt of that report (Rule 48.2(g))*

SEALING DEVICES FOR SEALING INNER WALL SURFACES OF A WELLBORE AND METHODS OF INSTALLING SAME IN A WELLBORE

CROSS REFERENCE TO RELATED APPLICATIONS

[0001] This application claims the benefit of U.S. Application No. 13/152346, filed on June 3, 2011, which is incorporated herein by reference in its entirety.

BACKGROUND

1. Field of Invention

[0002] The invention is directed to sealing devices for sealing a leak path through an inner wall surface of a wellbore and, in particular, to sealing devices having a shape deforming element that can be moved from a run-in shape to a set shape in which the sealing device is secured to the inner wall surface of the wellbore.

2. Description of Art

[0003] In subterranean wellbores, undesirable flow paths can occur. These may be the result of existing fractures present in the formation or occurring after some time, or they may be holes or perforations in the well casing or tubing that intersect a formation that is either taking fluid or producing an undesirable fluid (such as water). One way address these issues is to seal off portions of a wellbore containing the undesirable flow paths such as by disposing plugs, packers, or other sealing elements within the wellbore above and below the fractures. Because the zone comprising the fracture is isolated by the packers or other sealing devices, access to the region below the isolated section can be denied or geometrically limited by the bore in packer.

SUMMARY OF INVENTION

[0004] Broadly, sealing devices for use in a wellbore to seal a leak path through an inner wall surface of the wellbore are disclosed. In one specific embodiment, the sealing device comprises a tubular member or mandrel, an expandable element, and a shape deforming sealing element. Expansion or inflation of the expandable element moves the shape deforming sealing element from its run-in shape to its set shape. A stimulus, such as a change in temperature, acts upon the shape deforming sealing element facilitating the shape deforming sealing element changing shape. Removal of the stimulus causes the shape deforming sealing element to remain in the set shape. Thereafter, the mandrel and

expandable element can be removed to leave only the shape deforming sealing element within the wellbore to seal the leak path.

BRIEF DESCRIPTION OF DRAWINGS

[0005] FIG. 1 is a cross-sectional view of one specific embodiment of a sealing device shown with an expandable element in a collapsed position and a shape deforming sealing element in a run-in shape.

[0006] FIG. 2 is a cross-sectional view of the sealing device of FIG. 1 shown with the expandable element in a partially expanded position and the shape deforming sealing element in the run-in shape.

[0007] FIG. 3 is a cross-sectional view of the sealing device of FIG. 1 shown with the expandable element in an expanded position and the shape deforming sealing element in a set shape.

[0008] FIG. 4 is a cross-sectional view of the sealing device of FIG. 1 shown with the expandable element in the collapsed position and the shape deforming sealing element in a set shape.

[0009] FIG. 5 is a cross-sectional view of another specific embodiment of a sealing device shown with an expandable element in a collapsed position and a shape deforming sealing element in a run-in shape.

[0010] FIG. 6 is a cross-sectional view of one specific embodiment of a sealing device shown with the expandable element in an expanded position and a shape deforming sealing element in a set shape.

[0011] While the invention will be described in connection with the preferred embodiments, it will be understood that it is not intended to limit the invention to that embodiment. On the contrary, it is intended to cover all alternatives, modifications, and equivalents, as may be included within the spirit and scope of the invention as defined by the appended claims.

DETAILED DESCRIPTION OF INVENTION

[0012] Referring now to FIGS. 1-4, wellbore 10 is disposed in formation 14. Wellbore 10 comprises inner wall surface 12. Disposed in inner wall surface 12 is leak path 16. Wellbore 10 can be an open-hole wellbore or a cased wellbore. Thus, as used herein, the term "wellbore" is given its broadest meaning to include both open-hole wells or wellbores and cased wells or wellbores.

[0013] One embodiment of the sealing devices disclosed herein is shown with reference to FIGS. 1-4. Sealing device 20 comprises tubular member or mandrel 22 having outer wall surface 24 and inner wall surface 26 defining bore 28. One or more ports 29 are disposed in mandrel 22 placing bore 28 in fluid communication with outer wall surface 24.

[0014] Disposed along outer wall surface 24 of mandrel 22 is expandable element 30. Expandable element 30 may be formed of an elastomeric material or any other material that facilitates radial expansion of expandable element 30. In one particular embodiment, expandable element 30 is an inflatable element, such as a bladder, having interior area 38 for receiving a fluid to cause expansion or inflation. In these embodiments, ports 29 are in fluid communication with interior area 38 so that a fluid pumped down bore 28 can enter interior area 38 and expand expandable element 30.

[0015] Expandable element 30 comprises upper end 31, lower end 32, inner wall surface 34, outer wall surface 36, and interior area 38 (FIGS. 2-3). In the embodiment shown in FIGS. 1-4, expandable element 30 is secured to outer wall surface 24 of mandrel 20 at upper and lower ends 31, 32. Securing upper and lower ends 31, 32 to mandrel 20 can be accomplished through any device or method known in the art. As discussed in greater detail below, expandable element 30 comprises a first or run-in position (FIG. 1), an expanded position (shown in FIG. 3), and one or more intermediate positions, one of which is shown in FIG. 2.

[0016] Releasably attached to outer wall surface 36 of expandable element 30 is shape deforming sealing element 40. Shape deforming sealing element 40 comprises inner wall surface 42 and outer wall surface 44. Inner wall surface 42 is operatively associated with outer wall surface 36 of expandable element 30 so that upon being disposed in the set position (discussed in greater detail below), shape deforming sealing element 40 will be released from outer wall surface 36 of expandable element 30 so that shape deforming sealing element 40 can be left within the wellbore 10 when mandrel 20 is removed.

[0017] Outer wall surface 44 of shape deforming sealing element 40 is adapted to be secured to inner wall surface 12 of wellbore 10 when shape deforming sealing element 40 is in the set position so that leak path 16 will be sealed.

[0018] In one particular embodiment, shape deforming sealing element 40 comprises a high temperature shape memory polymer. These types of materials change shape upon being heated to the material's transition temperature. Upon reaching the transition temperature, the materials deform automatically, or with the assistance of some other stimulus, e.g., force, so that the material takes another shape such as by returning to its

natural or “memorized” shape. Suitable high temperature shape memory polymers include polyurethane. Alternatively, shape deforming sealing element 40 can comprise curable elastomers such as nitrile rubber, EPDM, and perfluoroelastomers. Curable elastomers are those that can be deformed into another shape and that other shape can be maintained.

[0019] As illustrated in the embodiment of FIGS. 1-4, expandable element 30 and shape deforming sealing element 40 both comprise sleeves having variable inner diameters.

[0020] As shown in FIGS. 2-3, fluid (not shown) is pumped down bore 28 of mandrel 22 and through ports 29 into interior area 38 of expandable element 30 causing expandable element 30 to radially expand. In so doing, shape deforming sealing element 40 also radially expands until outer wall surface 44 engages inner wall surface 12 of wellbore 10 (FIG. 10). Additional fluid is pumped down bore 28 of mandrel 22 and through ports 29 into interior area 38 of expandable element 30 causing expandable element 30 to further radially expand and deform shape deforming sealing element 40 from the run-in shape (shown in FIGS. 1-2) to the set shape (shown in FIGS. 3-4). In so doing, leak path 16 is sealed by shape deforming sealing element 40. Thereafter, fluid pressure within interior area 38 of expandable element 30 is relieved causing expandable element 30 to collapse or return toward its run-in position. At this point, sealing device 20 can be removed from wellbore 10. In so doing, shape deforming sealing element 40 remains in place within wellbore 10 sealing leak path 16, yet permitting additional downhole tools to be performed below shape deforming sealing element 40. Because only shape deforming sealing element 40 remains in the wellbore, more of the inner diameter of wellbore 10 is unrestricted so that more downhole operations can be performed. For example, additional shape deforming sealing elements (not shown) can be run-in wellbore 10 below shape deforming sealing element 40 so that additional leak paths (not shown) can be sealed.

[0021] In one particular embodiment of the method of sealing leak path 16 using sealing device 20 shown in FIGS. 1-4, the fluid used to expand expandable element 30 is wellbore fluid disposed within wellbore 10. In another specific embodiment, the fluid is heated to a temperature at which shape deforming sealing element 40 is deformable from the run-in shape (FIGS. 1-2) to the set shape (FIGS. 3-4). In still another embodiment, prior to collapsing or deflating expandable element 30 after shape deforming sealing element 40 is disposed in the set shape, the fluid in interior area 38 can be cooled to a lower temperature thereby causing shape deforming sealing element 40 to remain in the set shape. Moreover, expandable element 30 can be expanded from the collapsed position to the expanded position using known inflation methods, whether on wireline or tubing strings.

[0022] Referring now to FIGS. 5-6, in another embodiment, sealing device 120, having the same components as the embodiment of FIGS. 1-4 and, thus, like reference numerals, further comprises support sleeve 50 and one or more pressure relief devices 60 operatively associated with interior area 38 of expandable element 30. As shown in the embodiment of FIGS. 5-6, four pressure relief devices 60 are disposed in fluid communication with interior area 38 of expandable element 30. Pressure relief devices 60 are shown as one-way check valves, although pressure relief devices 60 can be any known pressure relief devices. In the embodiment of FIGS. 5-6, pressure relief devices 60 include flange portions 62 that facilitate attaching first and second ends 31, 32 to outer wall surface 24 of mandrel 22.

[0023] Support sleeve 50 comprises an expandable tubular member having inner wall surface 52 operatively associated with outer wall surface 36 of expandable element 30 and outer wall surface 54 operatively associated with inner wall surface 42 of shape deforming sealing element 40. Support sleeve 50 expands with shape deforming sealing element 40 and, after shape deforming sealing element 40 is placed in the set shape, support sleeve is released from expandable element 30 so that shape deforming sealing element 40 and support sleeve 50 are left in wellbore 10. As a result, support sleeve 50 provides mechanical back-up to shape deforming sealing element 40 to facilitate maintaining shape deforming sealing element 40 in the set position and in sealing engagement with inner wall surface 12 of wellbore 10. In one embodiment, support sleeve comprises a slotted tubular member formed of a high temperature polymer or metallic material.

[0024] Operation of the embodiment of FIGS. 4-5 is similar to the embodiment of FIGS. 1-2, however, the fluid flowing into interior area 38 for expansion or inflation of expandable element 30 is permitted to flow out of interior area 38 through pressure relief devices 60. As a result, the temperature of the fluid can be increased or decreased as desired to facilitate moving shape deforming sealing element 40 from the run-in shape to the set shape. For example, fluid at a first temperature can be initially pumped down bore 28 through ports 29 and into interior area 38 of expandable element 30 causing expandable element 30 to expand or inflate to the expanded position. As peak pressure is achieved within interior area 38, pressure relief device(s) 60 are actuated allowing pressure, e.g., fluid within interior area 38 to be released. Therefore, new fluid, at a second, different, temperature, can be pumped into interior area 38.

[0025] In one embodiment, the temperature of the fluid being pumped into interior area 38 can be increased to the transition temperature of the material forming shape

deforming sealing element 40. As the fluid flows into expandable element 30 and the transition temperature is reached, shape deforming sealing element 40 begins to move from the run-in shape toward the set shape. As a result, expandable element 30 continues to expand until shape deforming sealing element 40 reaches the set position, covers leak path 16, and is engaged with inner wall surface 16 of wellbore 10. Thereafter, fluid having a lower temperature can be pumped into interior area 38. This cooler fluid displaces the higher temperature fluid within interior area 38 by forcing the higher temperature fluid out of interior area 38 through pressure relief devices 60. Lowering the temperature of the fluid within interior area 38 below the transition temperature of the material forming shape deforming sealing element 40 causes shape deforming sealing element 40 to be retained in the set position. Accordingly, shape deforming sealing element 40 is sealed against and attached to inner wall surface 16 of wellbore 10, thereby sealing leak path 16.

[0026] As discussed above, sealing devices 20, 120 can be disposed within a wellbore using a conventional tubing string through which fluid is pumped or on electric wireline through-tubing. In the case of electric wireline through-tubing, an electric wireline setting tool can use fluid from the wellbore to be simultaneously heated by the setting tool and pumped into interior area 38 of the expandable element 30. Alternatively, the expandable element can have a battery powered or electric wireline powered heating element disposed within or in fluid communication with interior area 38 of expandable element 30. In another embodiment, the heating element can be operatively associated with shape deforming sealing element 40. Further, a spring-powered syringe pump can be coupled to the inlet of expandable element 30 to facilitate inflation or expansion of expandable element 30. As shape deforming sealing element 40 is heated and begins to deform, the decreasing modulus of shape deforming sealing element 40 allows expandable element 40 to expand via the stored energy in the spring.

[0027] It is to be understood that the invention is not limited to the exact details of construction, operation, exact materials, or embodiments shown and described, as modifications and equivalents will be apparent to one skilled in the art. For example, pressure relief devices are not required. Moreover, if a pressure relief device is included, only one can be sufficient to displace the fluid within the interior of the expandable element. In addition, one or more attachment members may be included on the outer wall surface of the shape deforming sealing element to facilitate the shape deforming sealing element maintaining its connection to the inner wall surface of the wellbore. Further, the sealing devices can be disposed in a wellbore using tubular strings as well as electric wireline

strings. Additionally, the sealing devices can be used in open-hole or cased wellbores. Accordingly, the invention is therefore to be limited only by the scope of the appended claims.

CLAIMS

WHAT IS CLAIMED IS:

1. A sealing device for use in a wellbore to seal a leak path through an inner wall surface of the wellbore, the sealing device comprising:

a tubular member comprising an outer wall surface and an inner wall surface;

an expandable element, the expandable element being disposed on the outer wall surface of the tubular member, the expandable element comprising an outer wall surface, a collapsed position, and an expanded position; and

a shape deforming sealing element, the shape deforming sealing element comprising a run-in shape and a set shape, the shape deforming sealing element being releasably connected to the outer wall surface of the expandable element, the shape deforming sealing element comprising an outer wall surface adapted to be secured to an inner wall surface of a wellbore when the shape deforming sealing element is in the set shape,

wherein expansion of the expandable element from the collapsed position to the expanded position moves the shape deforming sealing element from the run-in shape to the set shape, and

wherein the shape deforming sealing element is adapted to be secured to the inner wall surface of the wellbore after collapsing the expandable element from the expanded position to the collapsed position.

2. The sealing device of claim 1, wherein the shape deforming sealing element comprises a sleeve disposed around the outer wall surface of the expandable element and the expandable element comprises an elastomeric bladder disposed around the outer wall surface of the tubular member.

3. The sealing device of claim 2, wherein the inner wall surface defines a tubular member bore, the tubular member further comprising a port in fluid communication with the tubular member bore and an interior of the elastomeric bladder, and the elastomeric bladder being moved from the collapsed position to the expanded position by a fluid flowing through the port into the interior of the elastomeric bladder.

4. The sealing device of claim 3, wherein the expandable element further comprises at least one pressure relief device in fluid communication with the interior portion of the expandable element.

5. The sealing device of claim 4, wherein the pressure relief device is a valve.

6. The sealing device of claim 5, wherein the pressure relief device is a one-way check valve.

7. The sealing device of claim 1, wherein the shape deforming sealing element is formed by a temperature reactive material, the temperature reactive material having a transition temperature at which the temperature reactive material is deformable and below which the temperature reactive material is not deformable.

8. The sealing device of claim 1, wherein an expandable support member is disposed between the outer wall surface of the expandable element and an inner wall surface of the shape deforming sealing element, the expandable support member being releasably connected to the outer wall surface of the expandable element.

9. The sealing device of claim 8, wherein the expandable support member comprises a slotted metal tubular member.

10. A sealing device for use in a wellbore to seal a leak path through an inner wall surface of the wellbore, the sealing device comprising:

a mandrel comprising an outer wall surface and an inner wall surface;

an expandable element sleeve, the expandable element sleeve being disposed on the outer wall surface of the mandrel, the expandable element sleeve comprising an outer wall surface, a collapsed position, and an expanded position; and

a shape deforming sealing element sleeve, the shape deforming sealing element sleeve comprising a run-in inner diameter, a set inner diameter, and a plurality of intermediate inner diameters, the shape deforming sealing element sleeve being releasably connected to the outer wall surface of the expandable element sleeve, the shape deforming sealing element sleeve comprising an outer wall surface adapted to be secured to an inner wall surface of a wellbore when the shape deforming sealing element sleeve is in the set shape,

wherein expansion of the expandable element sleeve from the collapsed position to the expanded position moves the shape deforming sealing element sleeve from the run-in shape to the set shape, and

wherein the shape deforming sealing element sleeve is adapted to be secured to the inner wall surface of the wellbore after collapsing the expandable element sleeve from the expanded position to the collapsed position.

11. The sealing device of claim 10, wherein the inner wall surface of the mandrel defines a mandrel bore and the expandable element sleeve comprises an elastomeric bladder,

the mandrel further comprising a port in fluid communication with the mandrel bore and an interior of the elastomeric bladder, the elastomeric bladder being moved from the collapsed position to the expanded position by a fluid flowing through the port into the interior of the elastomeric bladder.

12. The sealing device of claim 11, wherein the expandable element sleeve further comprises at least one pressure relief device in fluid communication with the interior portion of the expandable element sleeve.

13. The sealing device of claim 10, wherein the shape deforming sealing element is formed by a temperature reactive material, the temperature reactive material having a transition temperature at which the temperature reactive material is deformable and below which the temperature reactive material is not deformable.

14. The sealing device of claim 13, wherein an expandable support member sleeve is disposed between the outer wall surface of the expandable element sleeve and an inner wall surface of the shape deforming sealing element sleeve.

15. The sealing device of claim 10, wherein shape deforming sealing element sleeve comprises a shape memory polymeric material.

16. A method of sealing a leak path through an inner wall surface of a wellbore, the method comprising the steps of:

(a) providing a sealing device comprising
a tubular member comprising an outer wall surface and an inner wall surface; and
a shape deforming sealing element operatively associated with the outer wall surface of the tubular member, the shape deforming sealing element comprising a run-in shape and a set shape, the shape deforming sealing element comprising an outer wall surface adapted to be secured to an inner wall surface of a wellbore when the shape deforming sealing element is in the set shape;

(b) disposing the sealing device in a wellbore aligning the shape deforming sealing element with a leak path in an inner wall surface of a wellbore;

(c) moving the shape deforming sealing element from the run-in shape to the set shape causing the shape deforming sealing element to be secured to the inner wall surface over the leak path; and

(d) removing the tubular member from the wellbore leaving the shape deforming sealing element in the wellbore.

17. The method of claim 16, wherein step (c) is performed by expanding with a first fluid an expandable element disposed on the outer wall surface of the tubular member, the first fluid being pumped into an interior of the expandable element.

18. The method of claim 17, wherein the first fluid comprises a first temperature at which the shape deforming sealing element is deformable from the run-in shape to the set shape.

19. The method of claim 17, wherein the expandable element comprises a pressure relief device operatively associated with the expandable element and during step (c) the first fluid is pumped into the expandable element at the first temperature at which the shape deforming sealing element is deformable from the run-in shape to the set shape and, thereafter, a second fluid is pumped down the bore of the tubular member into the expandable element displacing the first fluid, the second fluid being at a second temperature causing the shape deforming sealing element to remain in the set shape, the first temperature being higher than the second temperature.

20. The method of claim 17, wherein the first fluid is a wellbore fluid that is heated while being pumped into the expandable element.

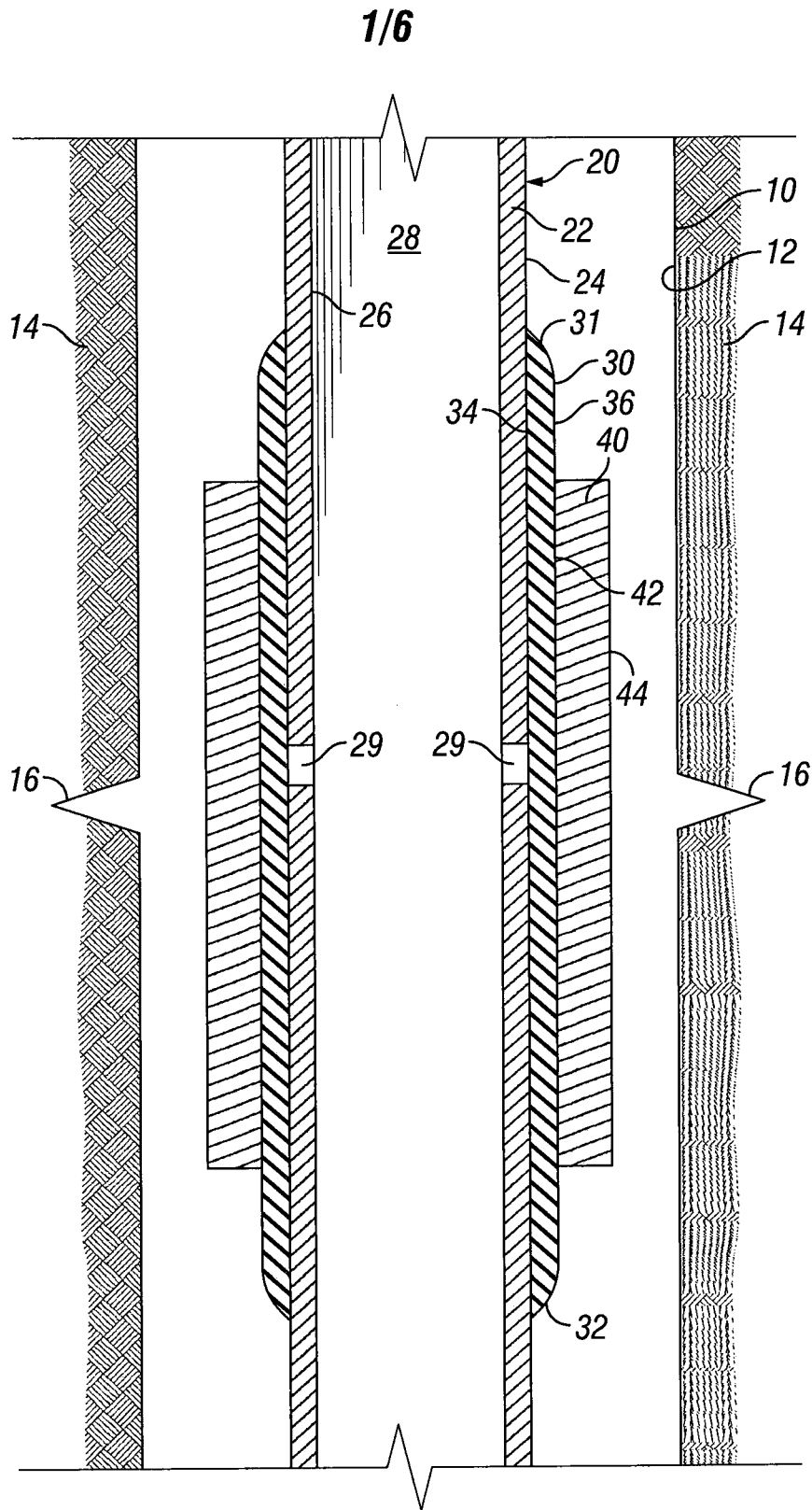

FIG. 1

2/6

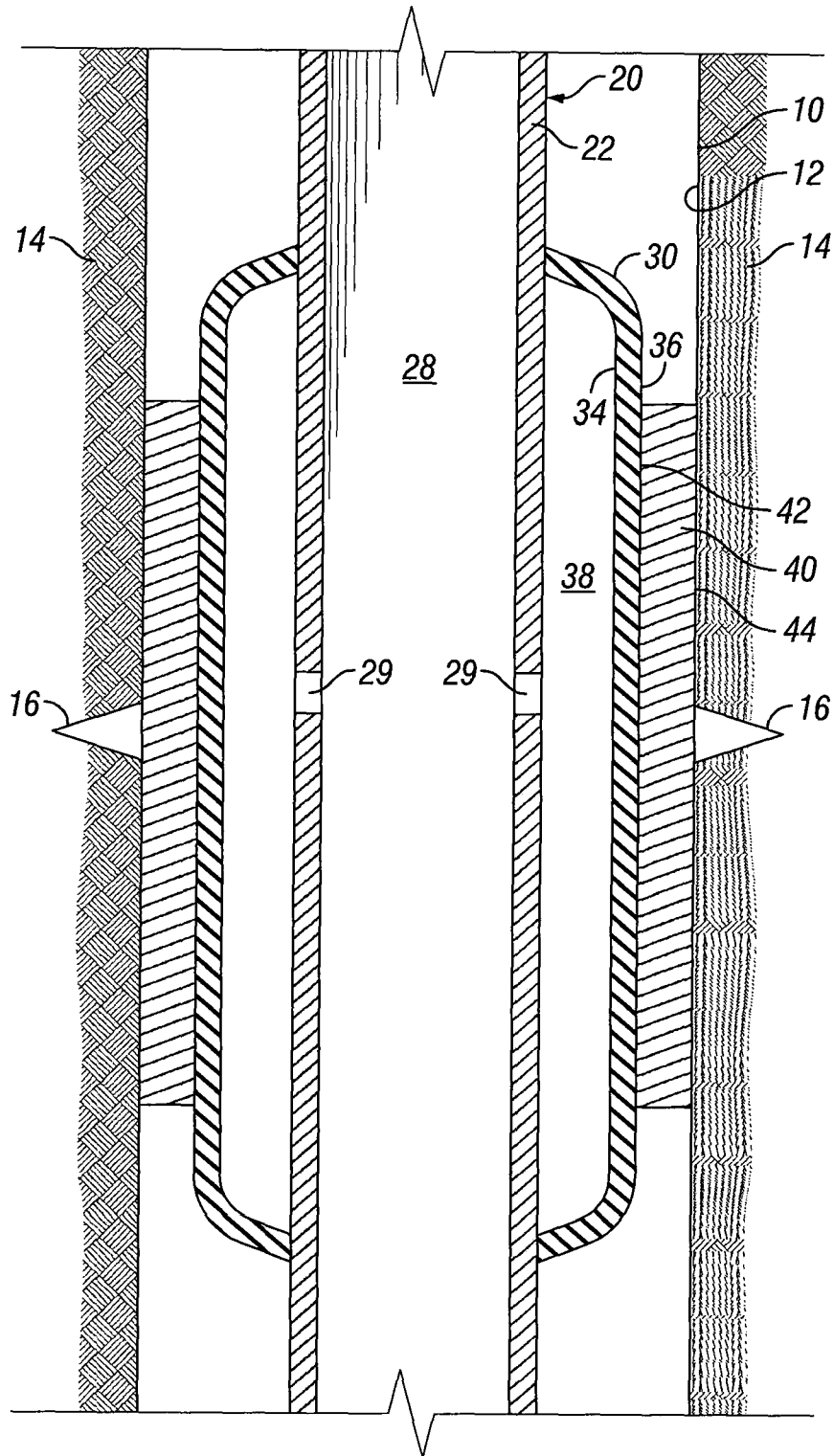

FIG. 2

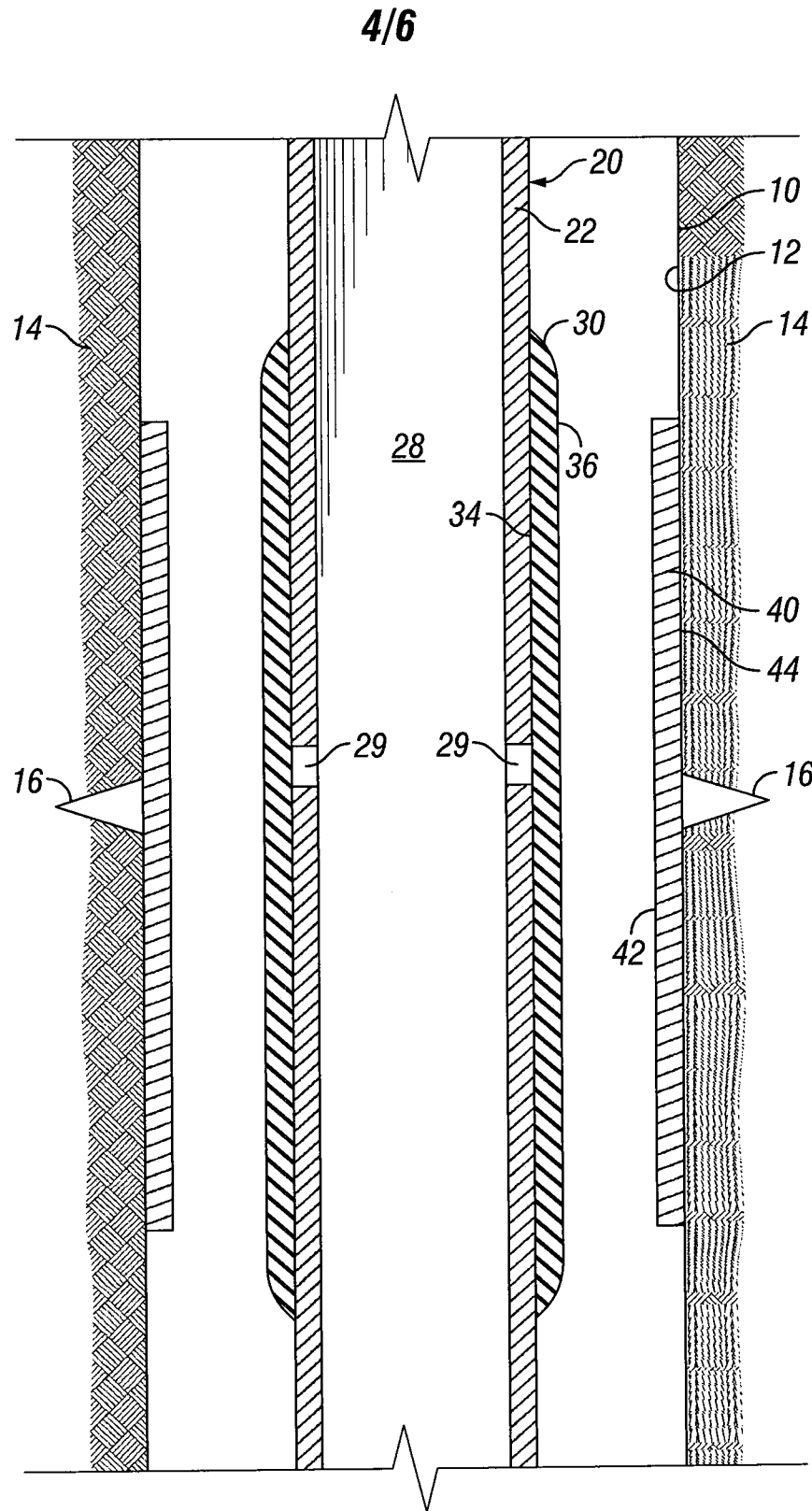

FIG. 4

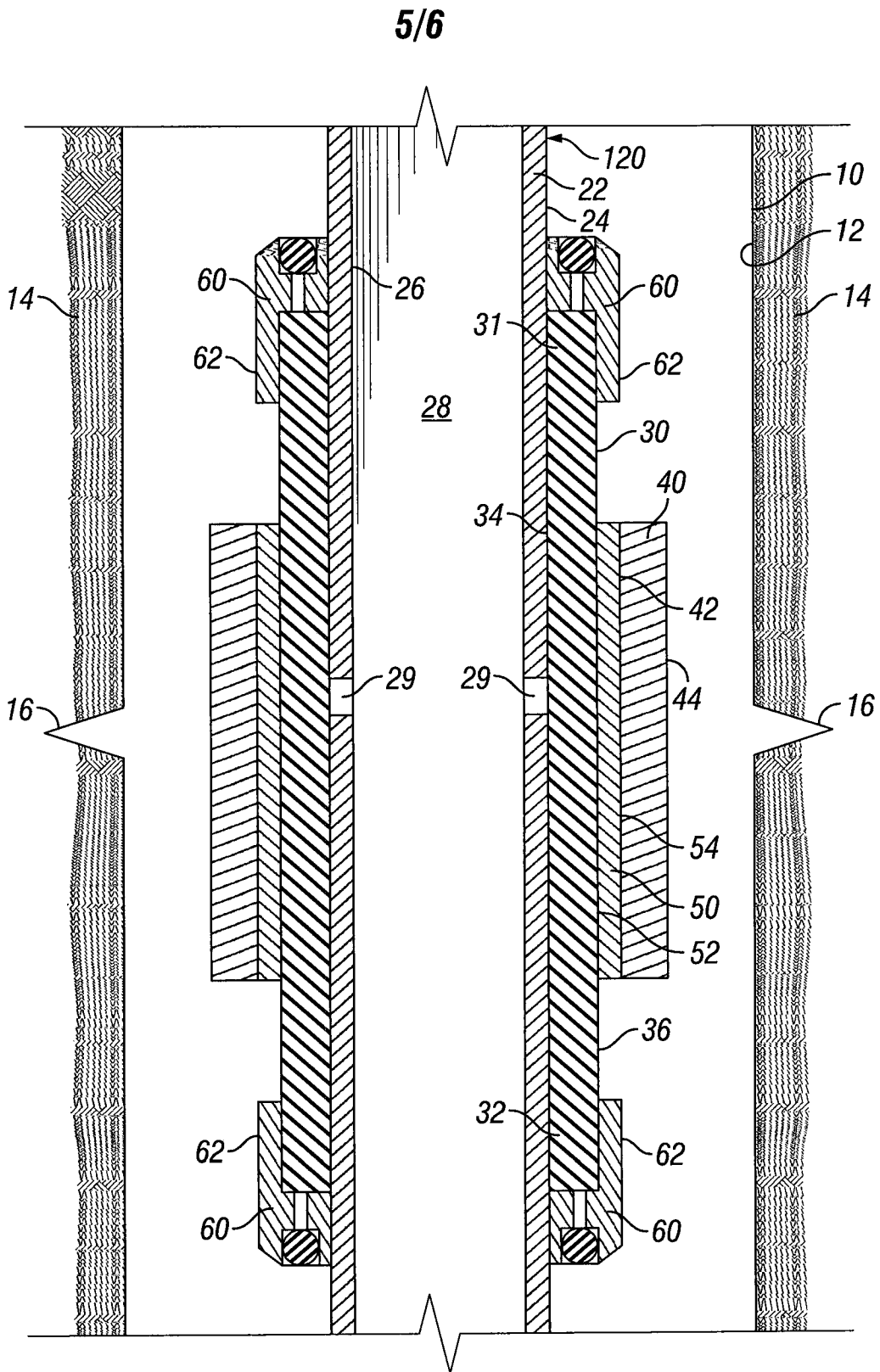

FIG. 5

6/6

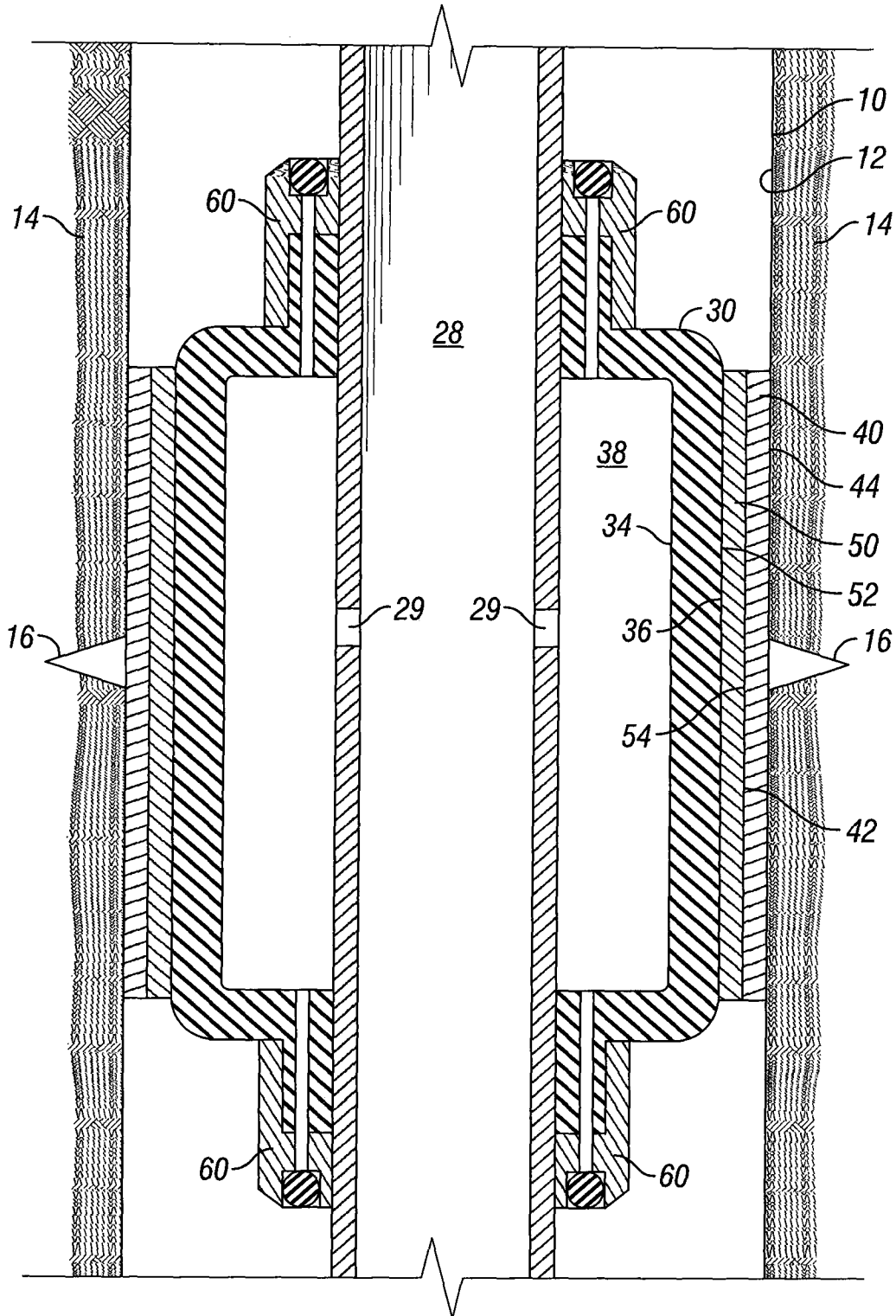

FIG. 6