



(51) International Patent Classification:

B65D 19/00 (2006.01) *E02D 29/02* (2006.01)
E04B 2/02 (2006.01)

(21) International Application Number:

PCT/US2018/033058

(22) International Filing Date:

16 May 2018 (16.05.2018)

(25) Filing Language:

English

(26) Publication Language:

English

(30) Priority Data:

62/507,206 16 May 2017 (16.05.2017) US

(71) Applicant: **NEWTON, William** [US/US]; 1441 N Sport of Kings Ct., Wichita, KS 67230 (US).

(72) Inventor: **KROEKER, Dan**; 1103 Barberry, Hutchinson, KS 67502 (US).

(74) Agent: **THOMPSON, Jeffrey, L.**; Thompson & Thompson, P.A., P.O. Box 166, Scandia, KS 66966 (US).

(81) Designated States (unless otherwise indicated, for every kind of national protection available): AE, AG, AL, AM, AO, AT, AU, AZ, BA, BB, BG, BH, BN, BR, BW, BY, BZ, CA, CH, CL, CN, CO, CR, CU, CZ, DE, DJ, DK, DM, DO, DZ, EC, EE, EG, ES, FI, GB, GD, GE, GH, GM, GT, HN, HR, HU, ID, IL, IN, IR, IS, JO, JP, KE, KG, KH, KN, KP,

KR, KW, KZ, LA, LC, LK, LR, LS, LU, LY, MA, MD, ME, MG, MK, MN, MW, MX, MY, MZ, NA, NG, NI, NO, NZ, OM, PA, PE, PG, PH, PL, PT, QA, RO, RS, RU, RW, SA, SC, SD, SE, SG, SK, SL, SM, ST, SV, SY, TH, TJ, TM, TN, TR, TT, TZ, UA, UG, US, UZ, VC, VN, ZA, ZM, ZW.

(84) Designated States (unless otherwise indicated, for every kind of regional protection available): ARIPO (BW, GH, GM, KE, LR, LS, MW, MZ, NA, RW, SD, SL, ST, SZ, TZ, UG, ZM, ZW), Eurasian (AM, AZ, BY, KG, KZ, RU, TJ, TM), European (AL, AT, BE, BG, CH, CY, CZ, DE, DK, EE, ES, FI, FR, GB, GR, HR, HU, IE, IS, IT, LT, LU, LV, MC, MK, MT, NL, NO, PL, PT, RO, RS, SE, SI, SK, SM, TR), OAPI (BF, BJ, CF, CG, CI, CM, GA, GN, GQ, GW, KM, ML, MR, NE, SN, TD, TG).

Published:

— with international search report (Art. 21(3))

(54) Title: QUAD FOOT NESTABLE BLOCK PALLET

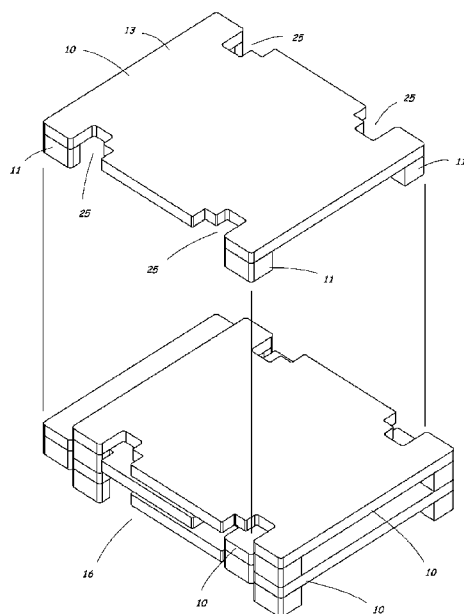

Fig. 5

(57) Abstract: A pallet (10, 10') has a rectangular pallet deck (13, 13') with a generally planar upper surface (14), and a plurality of pallet feet (11) connected by shear members (26) at the four corners. The pallet (10, 10') has an open bottom with a clear span between the pallet feet (11) to allow multiple pallets to be nested together. The pallet feet (11) each have an L-shaped cross section. Holes (25, 25') are formed in the pallet deck (13, 13') to accommodate pallet feet (11) of other pallets when the pallets are nested together. In one embodiment, pallets (10) are nested together by offsetting the pallets in a longitudinal direction. In another embodiment, pallets (10') are nested together by rotating the pallets a quarter turn relative to each other. A metal reinforcement frame (23) is provided inside a plastic exterior shell (24) to provide increased strength and reduced deflection.



QUAD FOOT NESTABLE BLOCK PALLET

TECHNICAL FIELD

[0001] The present invention relates generally to pallets, and in particular to a reusable pallet suitable for use in pallet pooling arrangements.

5

BACKGROUND ART

[0002] Pallets are flat transport structures that support materials and/or goods while being lifted or otherwise manipulated by material handling equipment, such as a forklift, pallet jack, or front loader. Pallets generally have a planar supporting surface and feet or runners that elevate the supporting surface above the ground to protect the supported goods from coming into contact with moisture, dirt and debris. Goods can be placed on a pallet, secured with strapping or stretch wrap, and shipped. Four-way pallets allow pallet jacks and forklifts to approach the pallets from any side to move them. Pallets can be made of a variety of materials, including wood, plastic and metal.

[0003] Pallet pooling is the shared use of standard pallets among multiple customers. Pallet pooling has become common to allow pallet users to outsource the expense, labor and skills required to deal with a high volume of pallets and focus on their core business. In pallet pooling arrangements, a pallet management company provides pallet users or shippers with reusable pallets at one end of a supply chain (e.g., at the user's warehouse). The reusable pallets are then retrieved by the pallet management company at the other end of the supply chain (e.g., at retail store locations). The pallets are then inspected, cleaned and reconditioned as needed, and then sent back into the supply chain for use by the same user or other users. In larger organizations, the empty pallets are transported by semi-loads to and from various locations in the supply chain. A standard 53' x 102" x 9' dry van trailer will hold approximately 540 conventional block pallets.

SUMMARY OF THE INVENTION

Technical Problem

[0004] There is a need for an improved pallet that can be nested when stacked in a semi-load of empty pallets, while still meeting or exceeding all of the functional requirements of a standard block pallet.

Solution to Problem

[0005] A pallet is provided that has a rectangular pallet deck with a generally planar upper surface, and a plurality of pallet feet connected by shear members at the four corners. The pallet has an open bottom with a clear span between the pallet feet to allow multiple pallets to be nested together. The pallet feet each have an L-shaped cross section. Holes are formed in the pallet deck to accommodate pallet feet of other pallets when the pallets are nested together. In one embodiment, pallets are nested together by offsetting the pallets in a longitudinal direction. In another embodiment, pallets are nested together by rotating the pallets a quarter turn relative to each other. A metal reinforcement frame is provided inside a plastic exterior to provide increased strength and reduced deflection.

Advantageous Effects of Invention

[0006] The nestable block pallet of the present invention allows a greater number of pallets to be transported in a semi-load of empty pallets. The pallet has a pallet deck with sufficient strength that the pallet only needs to be supported by feet located at the four corners of the pallet during use. The pallet has a pallet deck with a metal reinforcement frame inside a plastic exterior to provide increased strength. A shearable structure allows a foot of the pallet to become detached before damaging the pallet deck. The pallet is nestable with a foot design and holes in the pallet deck that allow pallet feet to slip through the deck top when pallets are nested together. The pallet has feet with a rack gripping foot tread design to prevent the pallet from slipping.

BRIEF DESCRIPTION OF DRAWINGS

[007] Fig. 1 is a perspective view of a nestable block pallet according to a first embodiment.

- [0008] Figs. 2 to 4 are plan, front and side views, respectively, of the block pallet shown in Fig. 1.
- [0009] Fig. 5 is a perspective view of a stack of nestable block pallets according to the first embodiment.
- 5 [0010] Figs. 6 and 7 are cross section views of a corner portion of the block pallet with a detachable foot according to the first embodiment.
- [0011] Fig. 8 is a cutaway perspective view of a corner portion of the block pallet with the detachable foot.
- [0012] Fig. 9 is an exploded perspective view of the corner portion of the block
10 pallet with the detachable foot.
- [0013] Fig. 10 is a perspective view of a nestable block pallet according to a second embodiment.
- [0014] Fig. 11 is a perspective view of a stack of nestable block pallets according to the second embodiment.
- 15 [0015] Fig. 12 is a plan view of the stack of block pallets shown in Fig. 11.
- [0016] Figs. 13 to 16 are perspective views of the detachable foot.
- [0017] Fig. 17 is a perspective bottom view of the nestable block pallet according to the first embodiment.
- [0018] Fig. 18 is a perspective bottom view of the nestable block pallet shown in
20 Fig. 17, with a lower cover in exploded view to show the metal reinforcement frame inside the pallet deck.
- [0019] Figs. 19 and 20 are bottom and perspective views of the nestable block pallet shown in Fig. 17, with the lower cover removed to show the metal reinforcement frame inside the pallet deck.
- 25 [0020] Figs. 21 and 22 are perspective and plan views of the metal reinforcement frame used in the pallet deck.
- [0021] Fig. 23 is a perspective view of a fork lift and storage rack with nestable block pallets supported on the storage rack.

DESCRIPTION OF EMBODIMENTS

[0022] A quad foot nestable block pallet 10, 10' according to embodiments of the present invention will now be described in detail with reference to Figs. 1 to 23 of the accompanying drawings.

5 **[0023]** Two embodiments of a nestable block pallet 10, 10' according to the present invention are illustrated in the drawings. A pallet 10 according to the first embodiment is illustrated in Figs. 1 to 5 and 17 to 22; and a pallet 10' according to the second embodiment is illustrated in Figs. 10 to 12. Replaceable feet 11 for the block pallets 10, 10' are shown in Figs. 6 to 9 and 13 to 16.

10 **[0024]** The present invention provides a quad foot nestable block pallet 10, 10' that uses a four corner block foot construction. Nestable pallets 10, 10' fit together when empty, thereby reducing the amount of space needed for storage. The block foot construction allows the pallets 10, 10' to be compatible with and sit on a standard pallet rack 12 designed for an industry standard pallet size (e.g., 1000 mm x 1200 mm or 40
15 inch x 48 inch).

[0025] The block pallet 10 has a rectangular pallet deck 13 with a generally planar upper surface 14. A plurality of pallet feet 11 are arranged to support the pallet deck 13 at the four corners of the pallet deck 13. In the preferred embodiments, the pallet 10 has only four pallet feet, which are located at each of the four corners of the pallet deck 13.

20 The pallet 10 is open on a bottom side 15 with a clear span between the pallet feet 11 to allow multiple pallets 10 to be nested together in a stack 16. The pallet deck 13 has sufficient strength that no additional supports are necessary between the pallet feet 11 at the four corners.

[0026] The pallet feet 11 each have an upper end 17 and a lower end 18. The
25 pallet feet 11 protrude downwardly from the four corners of the pallet deck 13 with the upper ends 17 of the pallet feet 11 engaging the pallet deck 13. The lower ends 18 of the pallet feet 11 engage a support surface, such as a floor or support rack 12, on which the pallet 10 is supported. The pallet feet 11 are only connected to each other via the pallet deck 13, thereby leaving a clear span between the lower ends of the pallet feet 11 to allow
30 multiple pallets 10 to be nested together in a stack 16.

[0027] The pallet has an overall height and an opening height below the pallet deck 13 sufficient to insert forks of a forklift 19 for lifting and moving the pallet 10. For

- 5 -

example, the overall pallet height can be approximately 144 mm (5.5 inches), and the opening height below the pallet deck can be approximately 90 mm (3.5 inches) to meet the functional requirements of an industry standard pallet.

[0028] With the pallets 10 nested together, the total height of the stack 16 is substantially less than the combined heights of the individual pallets 10. For example, in a stack of three nested pallets 10, the stack 16 will have a total height of approximately two times the height of one pallet 10. In a stack of five nested pallets 10, the stack 16 will have a total height of approximately three times the height of one pallet 10.

[0029] The pallet 10 has a length and a width, and the length is greater than the width. For example, to match the industry standard pallet size, the pallet length can be approximately 1200 mm (48 inches), and the pallet width can be approximately 1000 mm (40 inches).

[0030] The pallet feet 11 are each L-shaped in plan view with a long side 20, a short side 21, and a notch 22. The pallet feet 11 are each arranged with the long side 20 extending in a direction of the length of the pallet 10, and the short side 21 extending in a direction of the width of the pallet 10. In the first embodiment, the pallet feet 11 are arranged with the notches 22 facing inwardly toward each other. In the second embodiment, the pallet feet 11 are arranged with the notches 22 facing outwardly away from each other.

[0031] The block pallet 10 according to the present invention combines the strength from a conventional top and bottom board pallet into a rigid single deck 13 with minimal deflection and eliminates the need for a bottom support under the block feet 11. This elimination of the bottom support allows for a nestable block pallet 10. The pallet 10 also has openings on all four sides allowing four-way entry with the forks of a forklift 19.

[0032] In preferred embodiments, the pallet deck 13 is made of a metal reinforcement frame 23 covered by a plastic shell 24. The metal reinforcement frame 23 comprises a grid of flat metal elements that are welded or otherwise fastened together in a pattern to provide structural strength to support a load on the pallet deck 13 with a low amount of deflection. While a plastic reinforcement frame could be used instead of the metal reinforcement frame, a plastic frame without metal reinforcement will be more susceptible to material fatigue and sagging over an extended time period. The metal and

- 6 -

plastic materials used in the pallets 10 will resist insects, bacteria and fungi, and will also allow the pallets to be recyclable. The upper surface 14 of the pallet deck 13 is etched to help prevent the pallet contents from slipping.

[0033] In the pallet 10 according to the first embodiment, holes 25 are
5 strategically formed in the long sides of the pallet deck 13 between but adjacent to the locations where the pallet feet 11 are attached to the pallet deck 13. The holes 25 are substantially L-shaped in plan view to accommodate and correspond to the L-shaped pallet feet 11. The holes 25 are arranged to allow the block feet 11 of the second pallet 10 to slide through the deck 13 of the first pallet 10 directly behind the block feet 11 of the
10 first pallet 10, and the other set of feet 11 to hang over the narrow end of the first pallet 10. This allows the pallets 10 to rest deck-to-deck without rotating adjacent pallets 10 in the stack 16 relative to each other.

[0034] The clear span construction of the pallet 10 allows the pallet feet 11 of the third pallet 10 on the stack 16 to rest on the first pallet deck 13 directly over the four
15 block feet 11 of the first pallet 10 and allows a forklift space between the pallet decks 13 to enter and disassemble a stack of pallets 10. The pallet deck 13 of the second pallet 10 in the stack 16 is positioned between the pallet decks 13 of the first and third pallets 10. This stacking configuration is repeated, for example, until 35 pallets are put onto the stack 16, and will allow 910 pallets to be loaded in a standard semi box trailer, which compares
20 to a maximum of 540 conventional block pallets in the same trailer. The nested pallets 10 provide an improvement in space utilization and a substantial savings in transport costs to move empty pallets.

[0035] In the pallet 10' according to the second embodiment illustrated in Figs. 10 to 12, the holes 25' are formed in the long sides of the pallet deck 13' between but
25 adjacent to the locations where the pallet feet 11 are attached to the pallet deck 13'. The holes 25' are substantially rectangular in plan view to allow the pallets 10' to be nested when the second pallet 10' is turned a quarter of a turn. In this configuration, the second pallet 10' is turned 90 degrees and placed on the first pallet 10' with the feet 11 sliding through the holes 25' in the pallet deck 13' of the first pallet 10', and the second deck 13' resting on the top of the deck 13' of the first pallet 10'. The third pallet 10' on the stack
30 16' is then placed squarely on top of the first pallet 10' slipping through the holes 25' on the second pallet 10' and resting on the pallet deck 13' directly above the feet 11 of the

- 7 -

first pallet 10'. This pattern is repeated, for example, until 35 pallets are put onto the stack 16'. A standard semi box trailer will hold 26 stacks and a total of 910 pallets.

[0036] The nestable block pallet feet 11 are separate components of the pallet construction. The feet 11 are detachable from the pallet deck 13, 13' and are connected to the pallet deck 13, 13' by shear members 26. The shear members 26 each include a rod 27 that extends vertically through a bore 28 in the pallet feet 11. The rod 27 has an upper end 29 with a hook for attaching to a hole 30 in the metal reinforcement frame 23 of the pallet deck 13 and a lower threaded end 31. A nut 32 is threaded onto the lower end 31 of the rod 27 to secure the pallet feet 11 to the pallet deck 13. Each shear member 26 will be able to absorb an impact of normal operating forces, but will shear and allow the feet 11 to detach upon encountering a greater force, such as a direct hit by a forklift fork. The feet 11 can be replaced easily if they are damaged by simply bolting on a new foot 11.

[0037] The pallet feet 11 each have a hollow construction with an upper rim 33 that engages a lower surface of the pallet deck 13. The hollow construction minimizes weight while maintaining the structural strength of the feet 11. First and second protrusions 34, 35 extend upwardly from the upper rim 33 of the pallet feet 11 to engage a corresponding structure 36, 37 on the bottom side of the pallet deck 13 to keep the pallet feet 11 aligned relative to the pallet deck 13. The protrusions 34, 35 are shearable to allow the feet 11 to move relative to the pallet deck 13 when the feet 11 encounter a force, such as a direct hit by a forklift fork. A plurality of grooves 38 are formed in a bottom surface of the pallet feet 11 to provide a gripping foot tread.

[0038] The upper surface 14 of the pallet deck can be provided with a raised bead around the edge of the pallet deck 13. Additional raised beads can be provided at spaced intervals across the pallet deck 13. The raised beads can reduce the slip coefficient and help prevent products from slipping off of the pallet 10, 10'.

[0039] The nestable block pallets 10, 10' according to the present invention have several unique features, some of which are described below:

[0040] 1. Nestable Pallet Deck (first embodiment). The pallet 10 according to the first embodiment can be nested so that the pallet 10 overhangs on the narrow (i.e., 1000 mm or 40 inch) side of the pallet creating a 1000 mm x 1400 mm (or 40 inch x 54 inch) footprint. L-shaped holes 25 are provided in the deck 13 of the pallet 10 for the foot 11 of the next pallet 10 to slip through and the deck 13 of the second pallet 10 to rest on the

- 8 -

deck 13 of the first pallet 10. The third pallet 10 moves back to sit directly on top of the first pallet 10 again slipping through the L-shaped hole 25 in the deck 13 of the second pallet 10 directly on top of the first pallet 10. This pattern is repeated until 35 pallets are put onto the stack 16. A standard swing door 53 foot long dry van trailer will hold 26
5 stacks for a total of 910 pallets. The nestable pallets 10 of the first embodiment can thus be used in a pallet pooling system with increased transportation efficiencies between pallet users and shippers.

[0041] 2. Nestable Pallet Deck (second embodiment). The pallet 10' according to the second embodiment can be nested so that the pallet 10' overhangs the long (i.e., 1200
10 mm or 48 inch) side of the pallet creating a 1200 mm x 1200 mm (or 48 inch x 48 inch) foot print. A square hole 25' is provided in the deck 13' of the pallet 10' adjacent to each of the four pallet feet 11. For example, a square 75 mm x 75 mm (3 inch x 3 inch) hole 25' may be provided in the deck 13' of the pallet 10'. The second pallet 10' is turned a quarter of a turn and is placed on the first pallet 10' with the feet 11 sliding through the
15 pallet deck 13' and the second deck 13' resting on the top of the deck 13' of the first pallet 10'. The third pallet 10' is then placed squarely on top of the first pallet 10' slipping through the holes 25' on the second pallet 10' and resting on the pallet deck 13' directly above the feet 25' of the first pallet 10'. This pattern is repeated until 35 pallets are put onto the stack 16'. A standard swing semi van trailer will hold 26 stacks for a total of 910
20 pallets. The nestable pallets 10' of the second embodiment can thus be used in a pallet pooling system with increased transportation efficiencies between pallet users and shippers.

[0042] 3. Pallet Deck Construction. The pallet deck 13, 13' has a reinforcement metal frame 23 inside a plastic shell 24. The upper deck surface 14 is etched to prevent
25 pallet contents from slipping off the surface 14. The underneath side of the pallet 10, 10' is closed by the plastic shell 24.

[0043] 4. Shearable/Replaceable Foot. The shearable foot 11 allows the foot 11 of the pallet 10, 10' to become detached from the pallet deck 13, 13' by shearing off the shear members 26, 33, 34 used to connect the foot 11 to the deck 13, 13'. For example,
30 the plastic protrusions 33, 34 on the upper rims 32 of the feet 11 keep the feet 11 aligned and in place, and the threaded shear member 26 holds the foot 11 to the deck 13, 13'. The plastic protrusions 33, 34 are also designed to shear prior to damaging the pallet deck 13,

- 9 -

13'. The protrusions 33, 34 can then be removed from the pallet deck 13, 13', and a new foot 11 can be attached to the pallet deck 13, 13'.

[0044] 5. L-Shaped Foot. The L-shaped foot 11 allows more deck surface to be available to support the pallet contents while still allowing the pallet feet 11 to slip
5 through the deck top 13, 13' and the pallets 10, 10' to nest together. For example, the L-shaped foot 11 can be 130 mm (5 inches) on the short side 21, 165 mm (6 ½ inches) on the long side 20, and have a notch 22 of 64 mm x 64 mm (2 ½ inches x 2 ½ inches). In the first embodiment the notch 22 is provided on the inside of the pallet foot 11, and in the second embodiment the notch 22 is provided on the outside of the pallet foot 11 (e.g.,
10 the same pallet feet 11 can be used in the first and second embodiments, but rotated 180 degrees so that the notch 22 faces inwardly in the first embodiment and outwardly in the second embodiment).

[0045] 6. Rack Gripping Foot Tread. The bottom of each of the feet 11 have a series of deep grooves 35 for gripping the rack bars 12 and preventing the pallet 10, 10'
15 from slipping out of the rack 12. The grooves 35 run parallel to the short side of the pallet 10, 10'.

[0046] 7. Quad Foot Configuration. The nestable pallet 10, 10' of the present invention employs a quad foot configuration. The quad foot configuration utilizes an L-shaped foot 11 in each of the four corners of the pallet 10, 10'. The pallet deck 13, 13' is
20 made to support the pallet 10, 10' and its contents up to 1,364 kg (3,000 pounds) with deflection of less than 5 mm (3/16 inch). This eliminates the bottom boards required by conventional pallet construction to provide the necessary deck strength and allows easy entry for material handling equipment.

[0047] 8. Nestable and Rackable Pallet. The present invention provides a pallet
25 10, 10' that combines the rackability of a block pallet allowing the pallet 10, 10' to be placed in a rack 12 for storage with the space saving features of a plastic nestable pallet. The L-shaped foot 11 provides a similar surface area as a block pallet so that pallets 10, 10' can be stored lengthways or sideways in a standard size storage rack.

- 10 -

CLAIMS

1. A pallet (10, 10') comprising:
a rectangular pallet deck (13, 13') having a generally planar upper surface (14);
and
5 a plurality of pallet feet (11) arranged to support the pallet deck (13, 13') at four corners of the pallet deck (13, 13');
characterized by said pallet (10, 10') being open on a bottom side with a clear span between said pallet feet (11) to allow multiple pallets to be nested together in a stack (16, 16').
10
2. The pallet according to claim 1, wherein said pallet (10, 10') has a clear span construction that allows three such pallets to be positioned in a stack (16, 16') with the pallet feet (11) of a top pallet resting on the pallet deck (13, 13') of a bottom pallet, and the pallet deck (13, 13') of a middle pallet positioned between the pallet decks (13, 13') of
15 the top and bottom pallets.
3. The pallet according to claim 1, wherein said pallet feet (11) each have an upper end (17) and a lower end (18), and wherein said pallet feet (11) protrude downwardly from the four corners of said pallet deck (13, 13') with said upper ends (17)
20 of the pallet feet (11) adjacent to the pallet deck (13, 13'), said lower ends (18) of the pallet feet (11) providing a support surface for supporting the pallet (10, 10'), and said pallet feet (11) are only connected to each other by said pallet deck (13, 13') thereby leaving a clear span between the lower ends (18) of said pallet feet (11) to allow multiple pallets to be nested together in a stack (16, 16') having a total height less than the
25 combined heights of the multiple pallets.
4. The pallet according to claim 1, wherein said pallet (10, 10') has a length, a width and a height, said length being greater than said width, and said pallet (10, 10') has a clear span construction between said pallet feet (11) that allows three such pallets to be
30 nested together in a stack (16, 16') having a total height of approximately two times the height of one pallet.

- 11 -

5. The pallet according to claim 4, wherein said clear span construction of said pallet (10, 10') allows five such pallets to be nested together in a stack (16, 16') having a total height of approximately three times the height of one pallet (10, 10').

5 6. The pallet according to claim 1, wherein said plurality of pallet feet (11) comprises only four pallet feet (11), with one of said pallet feet (11) being located at each of the four corners of the pallet deck (13, 13').

7. The pallet according to claim 6, wherein each of said pallet feet (11) is L-
10 shaped in plan view with a long side (20), a short side (21), and a notch (22).

8. The pallet according to claim 7, wherein said pallet (10, 10') has a length and a width and the length is greater than the width, and wherein said pallet feet (11) are each arranged with the long side (20) extending in a direction of the length of the pallet (10,
15 10') and the short side extending in a direction of the width of the pallet.

9. The pallet according to claim 8, wherein said pallet feet (11) on the pallet (10) are each arranged with the notches (22) facing inwardly toward each other.

20 10. The pallet according to claim 8, wherein said pallet feet (11) on the pallet (10') are each arranged with the notches facing outwardly.

11. The pallet according to claim 1, wherein holes (25, 25') are formed in said pallet deck (13, 13') adjacent to each of the four corners to accommodate pallet feet (11)
25 of other pallets (10, 10') when the pallets are nested in a stack (16, 16').

12. The pallet according to claim 11, wherein said pallet deck (13, 13') has a length greater than a width, and first and second sides that extend in a direction of the length, and wherein said holes (25, 25') are formed in said first and second sides between
30 locations where the pallet feet (11) are attached to the pallet deck (13, 13').

- 12 -

13. The pallet according to claim 12, wherein said holes (25) are substantially L-shaped in plan view to accommodate L-shaped pallet feet (11) without rotating adjacent pallets (10) in a stack (16) relative to each other.

5 14. The pallet according to claim 12, wherein said holes (25') are substantially rectangular in plan view to accommodate pallet feet (11) with adjacent pallets (10') in a stack (16') rotated a quarter turn relative to each other.

15 15. The pallet according to claim 1, wherein said pallet deck (13, 13') comprises a
10 metal reinforcement frame (23).

16. The pallet according to claim 1, wherein an upper surface (14) of the pallet deck (13, 13') is etched to prevent pallet contents from slipping.

15 17. The pallet according to claim 1, wherein said pallet feet (11) are detachable from said pallet deck (13, 13') and connected to said pallet deck (13, 13') by shear members (26).

20 18. The pallet according to claim 17, wherein each of said shear members (26) comprises a rod (27) that extends through a bore (28) in the pallet feet (11), said rod (27) having an upper end (29) with a hook for attaching to a reinforcement frame (23) of the pallet deck (13, 13') and a lower threaded end (31), and a nut (32) threaded onto the lower end (31) of the rod (27) to secure the pallet feet (11) to the pallet deck (13, 13').

25 19. The pallet according to claim 18, wherein each of said pallet feet (11) has a hollow construction with an upper rim (33) that engages a lower surface of the pallet deck (13, 13'), and first and second protrusions (34, 35) extending upwardly from the upper rim (33) of said pallet feet (11) to engage a corresponding structure (36, 37) on the pallet deck (13, 13') to keep the pallet feet (11) aligned relative to the pallet deck (13, 13').

30

20. The pallet according to claim 1, wherein said pallet feet (11) each have a

- 13 -

plurality of grooves (38) formed in a bottom surface thereof to provide a gripping foot tread.

21. The pallet according to claim 1, wherein said pallet (10) has a construction
5 that allows multiple pallets to be nested together in a stack (16) by offsetting adjacent pallets in a longitudinal direction.

22. The pallet according to claim 1, wherein said pallet (10') has a construction
10 that allows multiple pallets to be nested together in a stack (16') by rotating adjacent pallets a quarter of a turn relative to each other.

23. A pallet pooling system, comprising:
a plurality of nestable block pallets (10, 10'), each pallet comprising a rectangular
pallet deck (13, 13') having a generally planar upper surface (14), and a plurality of pallet
15 feet (11) arranged to support the pallet deck (13, 13') at four corners of the pallet deck (13, 13');

characterized by said pallets (10, 10') each having an open bottom side with a clear
span between said pallet feet (11) to allow multiple pallets (10, 10') to be nested together
in a stack (16, 16'); and
20 said pallets (10, 10') are arranged in a stack (16, 16') for transport with adjacent
pallets nested together so that a height of the stack (16, 16') is substantially less than a
sum of individual heights of the pallets in the stack.

24. The pallet pooling system according to claim 23, wherein said pallets (10) are
25 nested together by offsetting adjacent pallets in the stack (16) in a longitudinal direction.

25. The pallet pooling system according to claim 23, wherein said pallets (10') are
nested together by rotating adjacent pallets in the stack (16') a quarter of a turn relative to
each other.

30

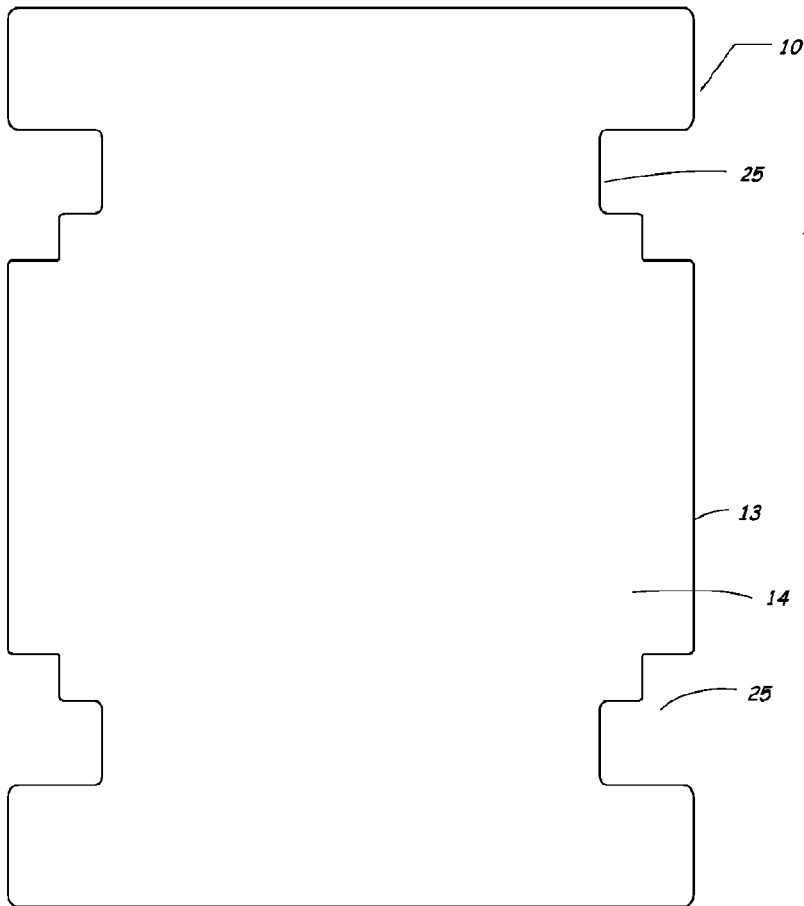

Fig. 2

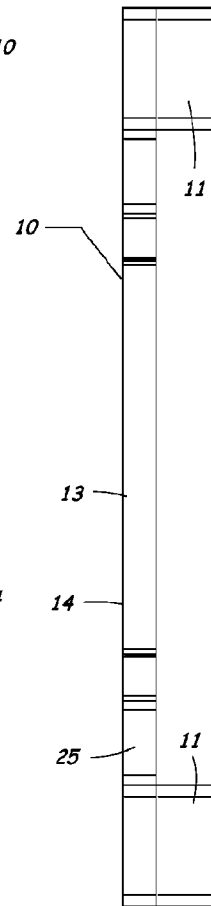

Fig. 4

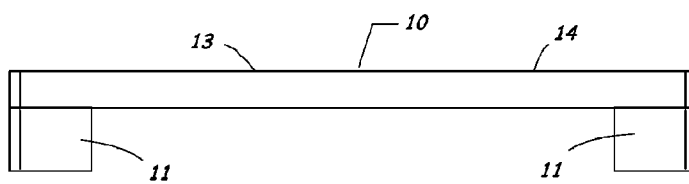

Fig. 3

3/17

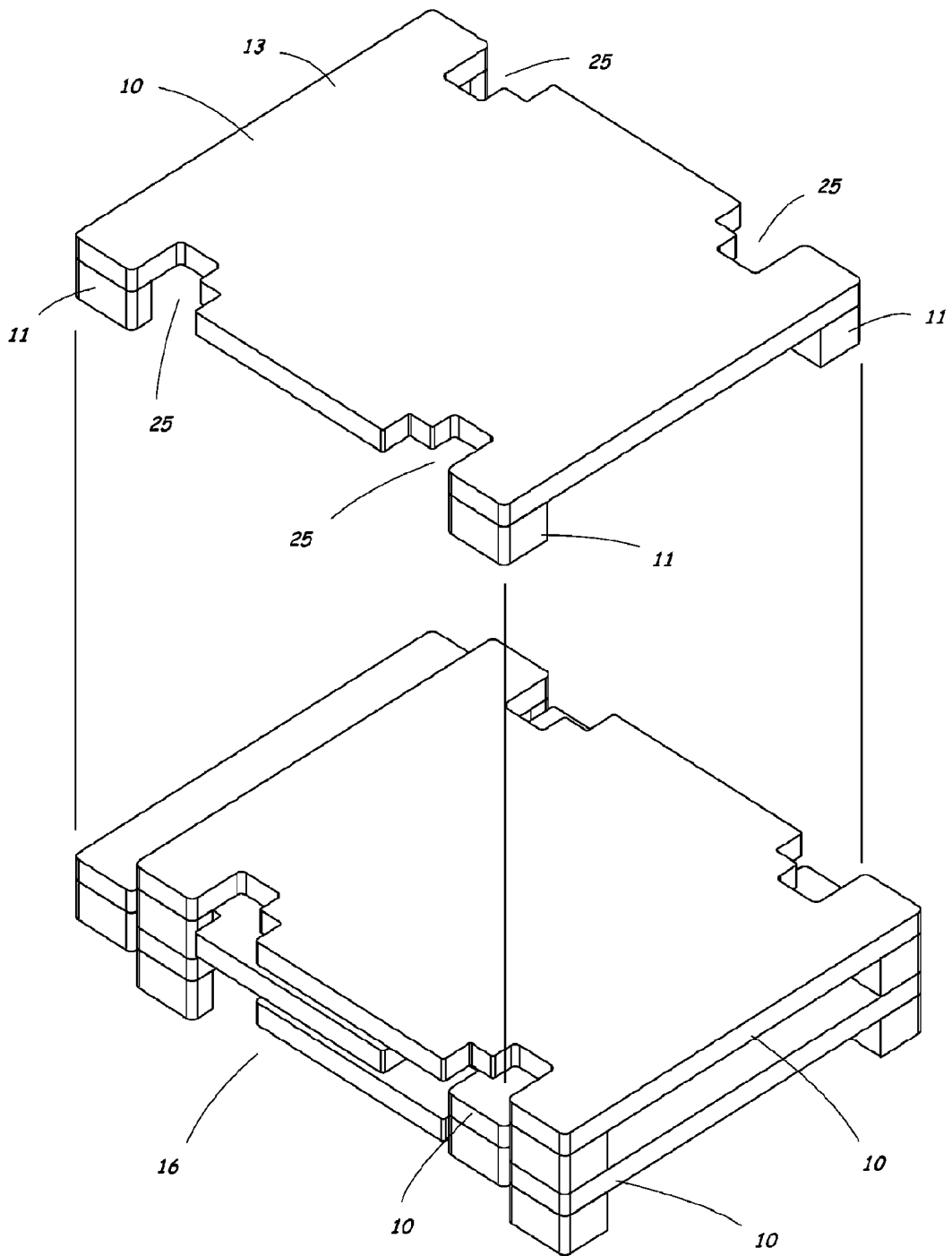

Fig. 5

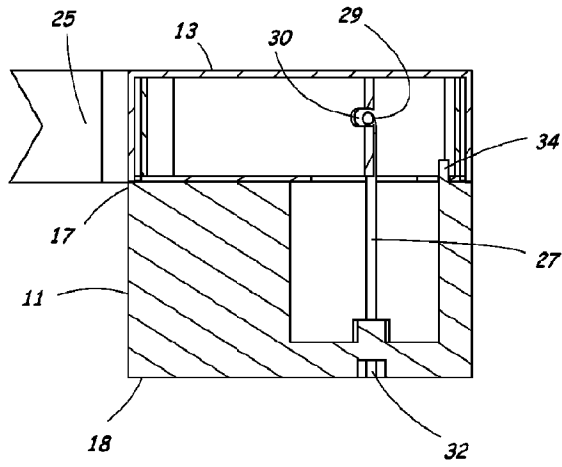

Fig. 6

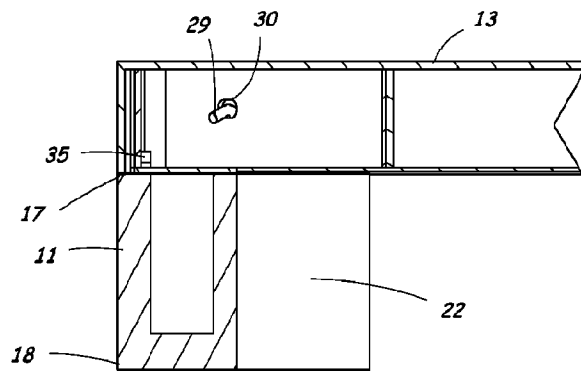

Fig. 7

5/17

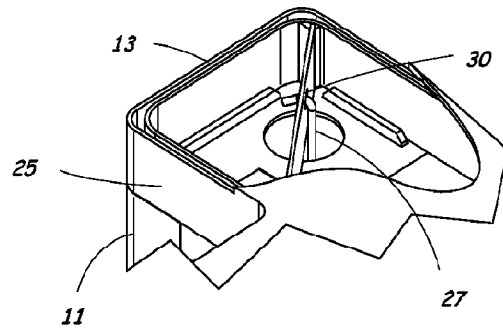

Fig. 8

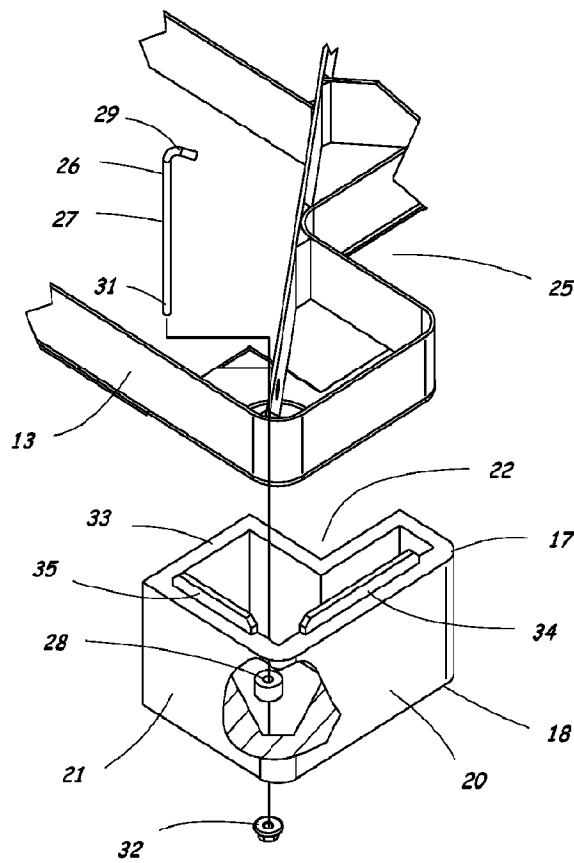

Fig. 9

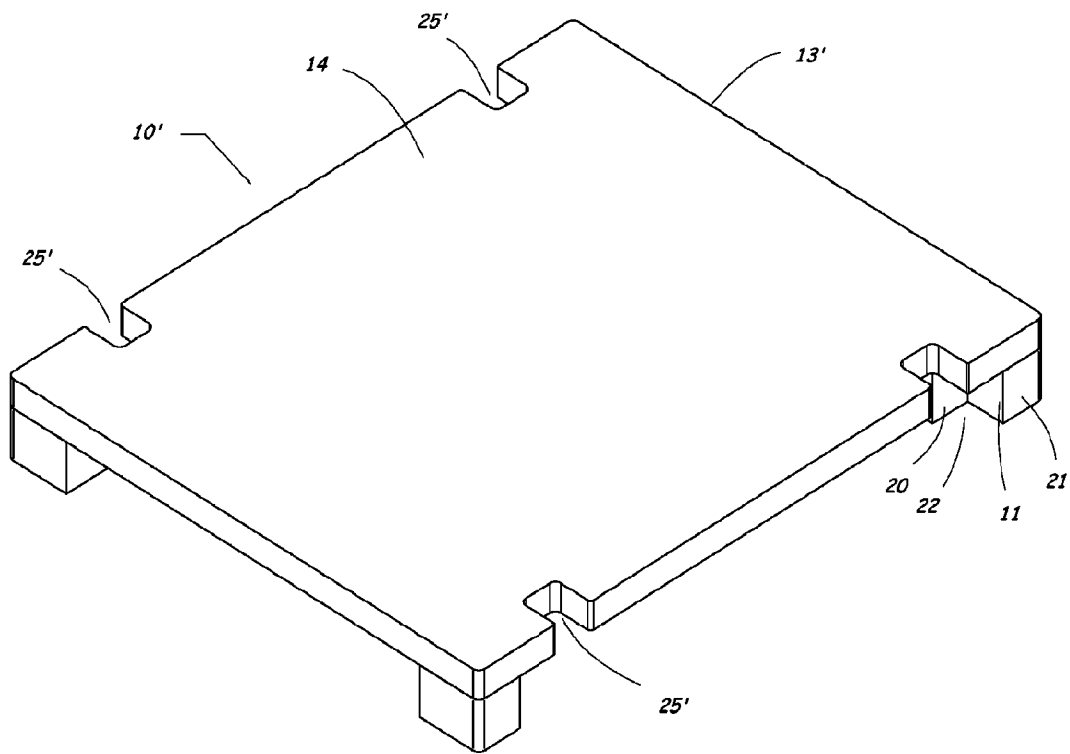

Fig. 10

7/17

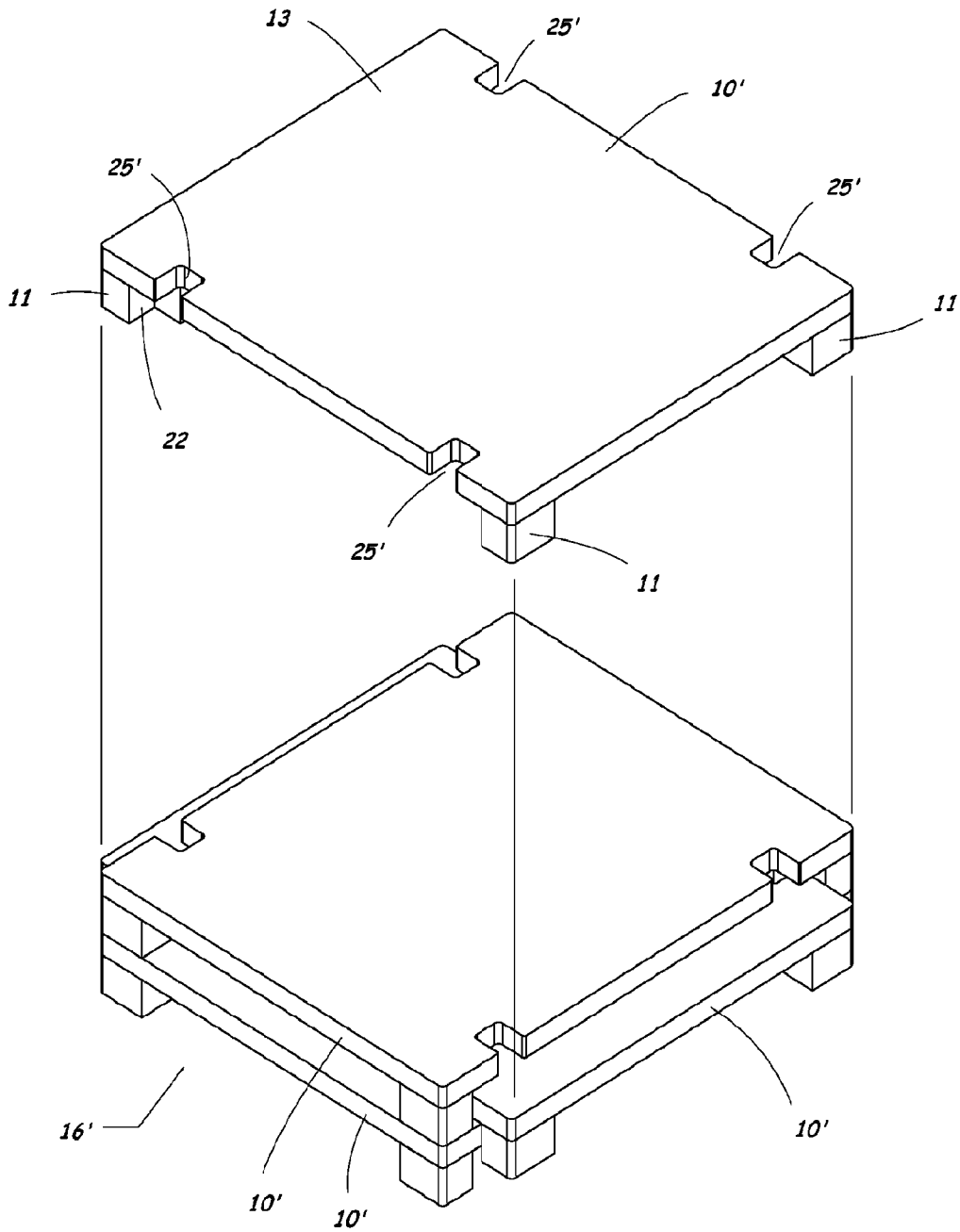

Fig. 11

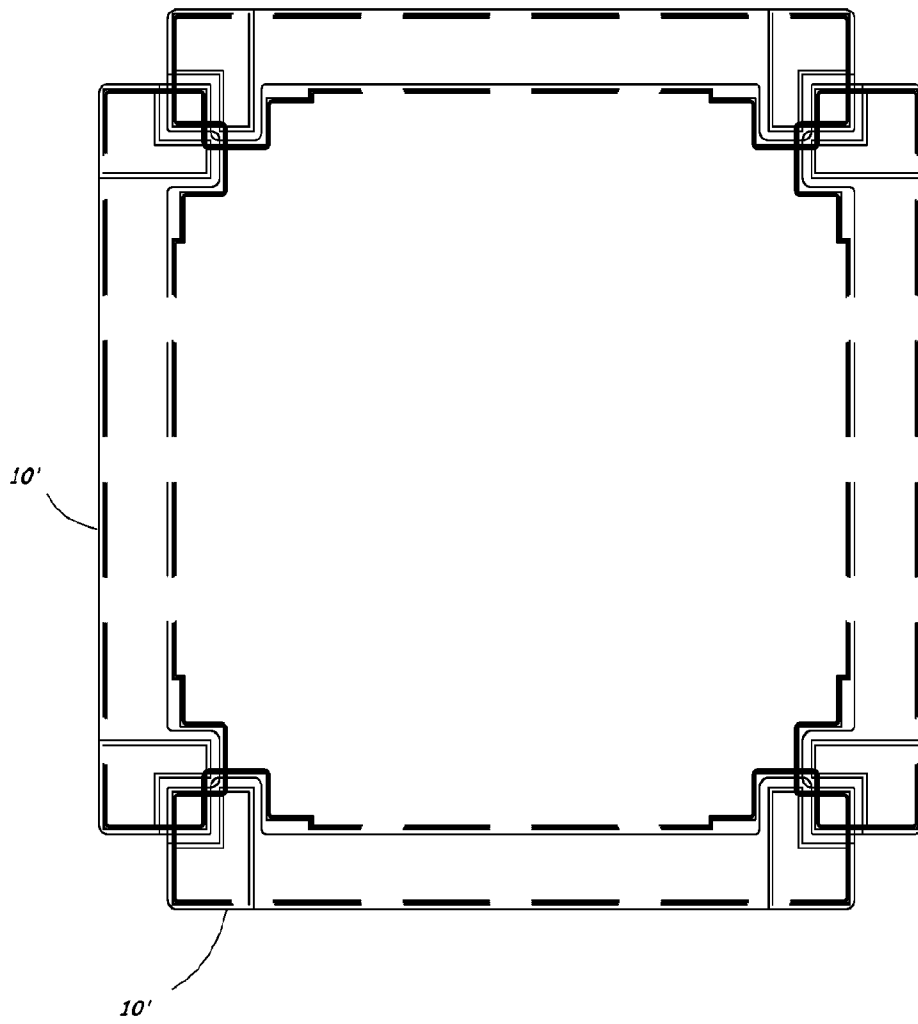

Fig.12

9/17

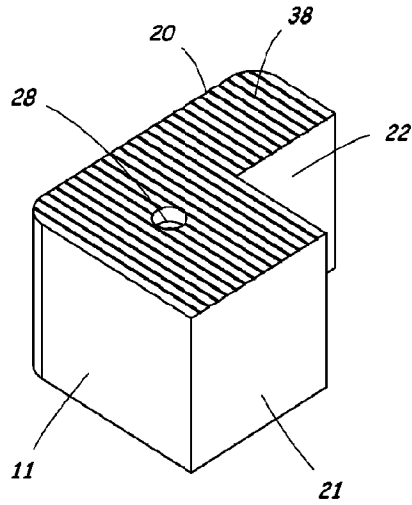

Fig. 13

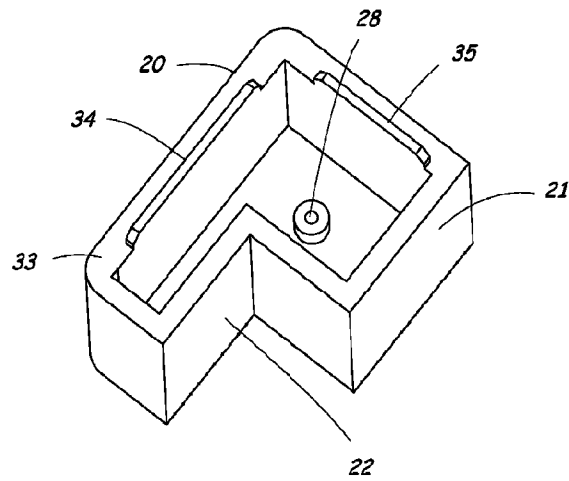

Fig. 14

10/17

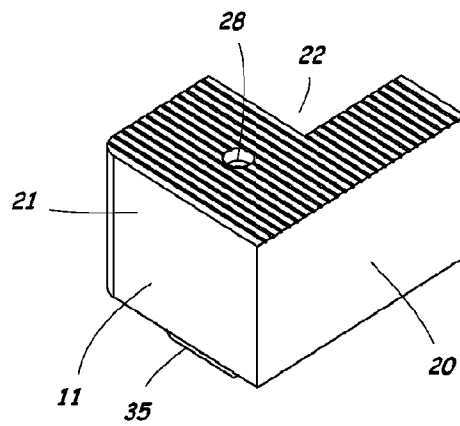

Fig. 15

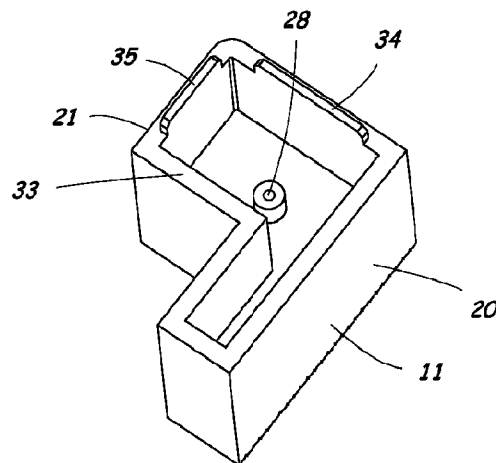

Fig. 16

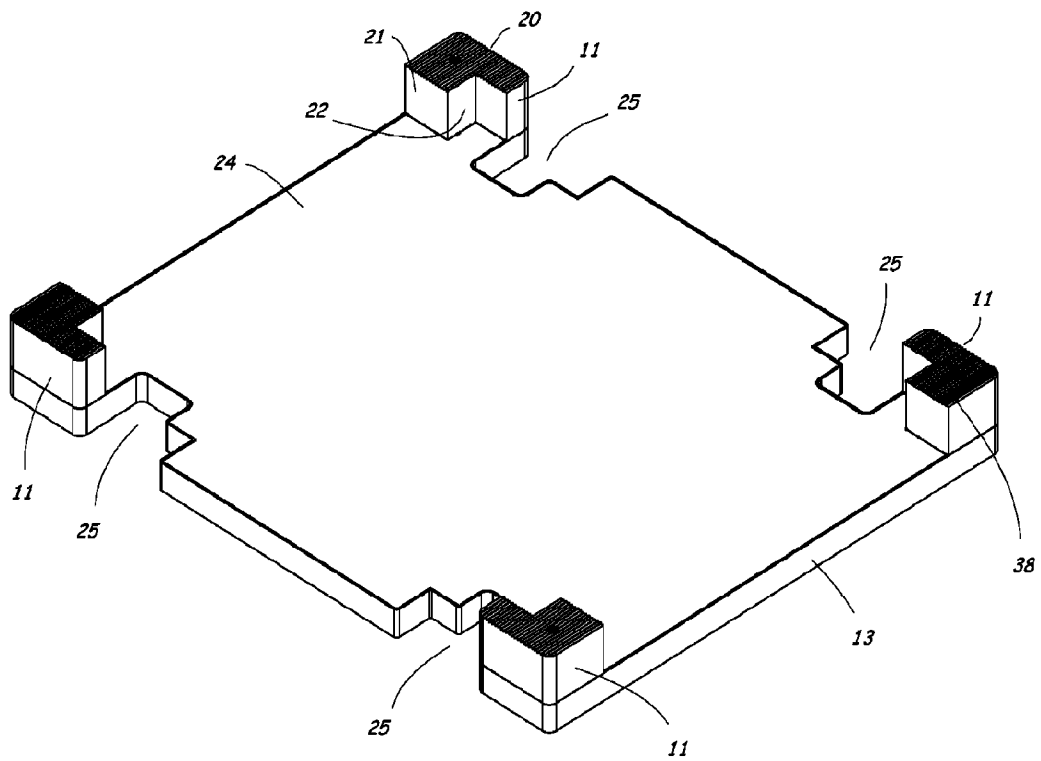

Fig.17

12/17

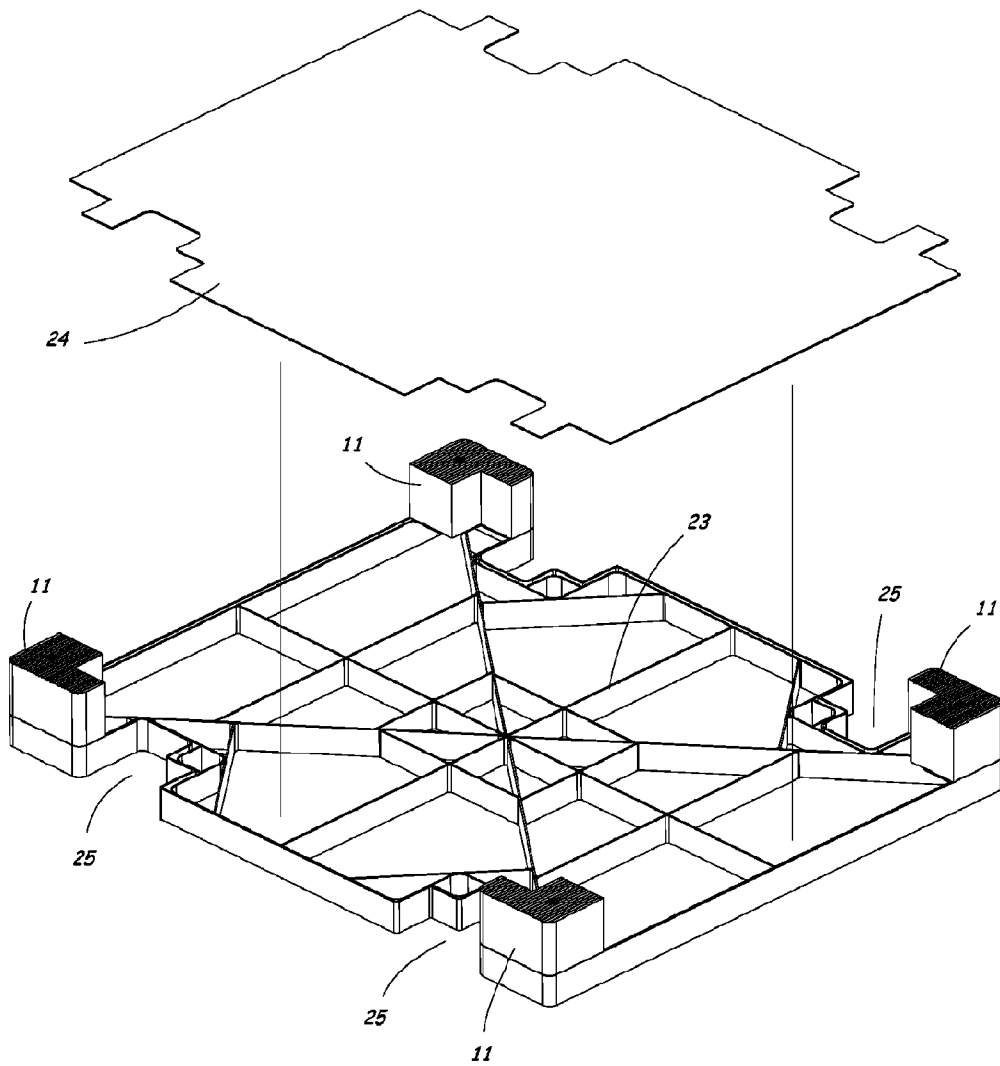

Fig. 18

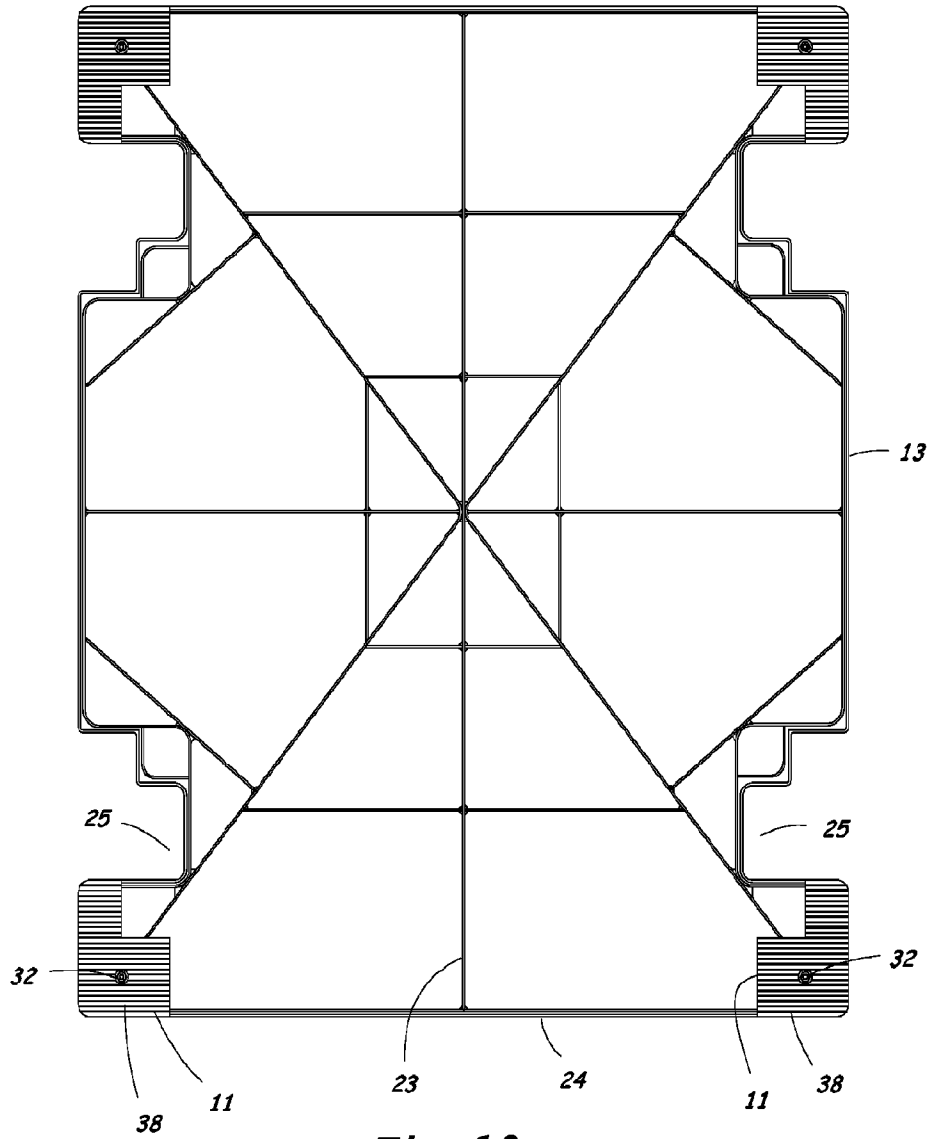

Fig. 19

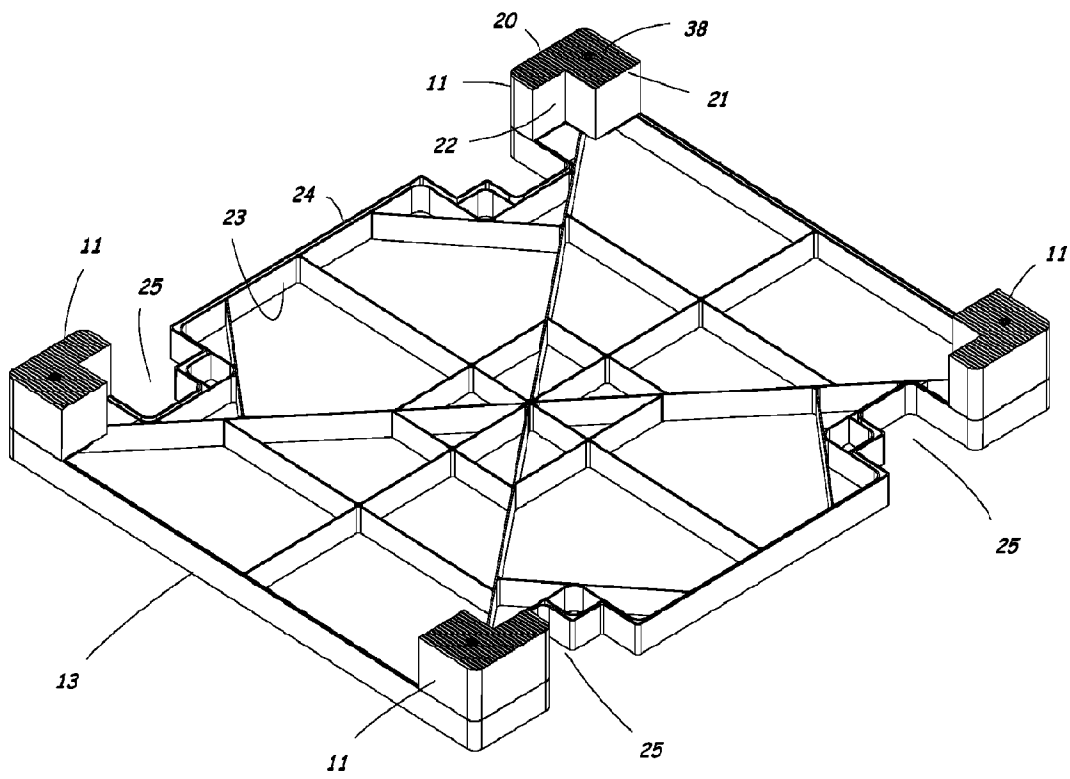

Fig. 20

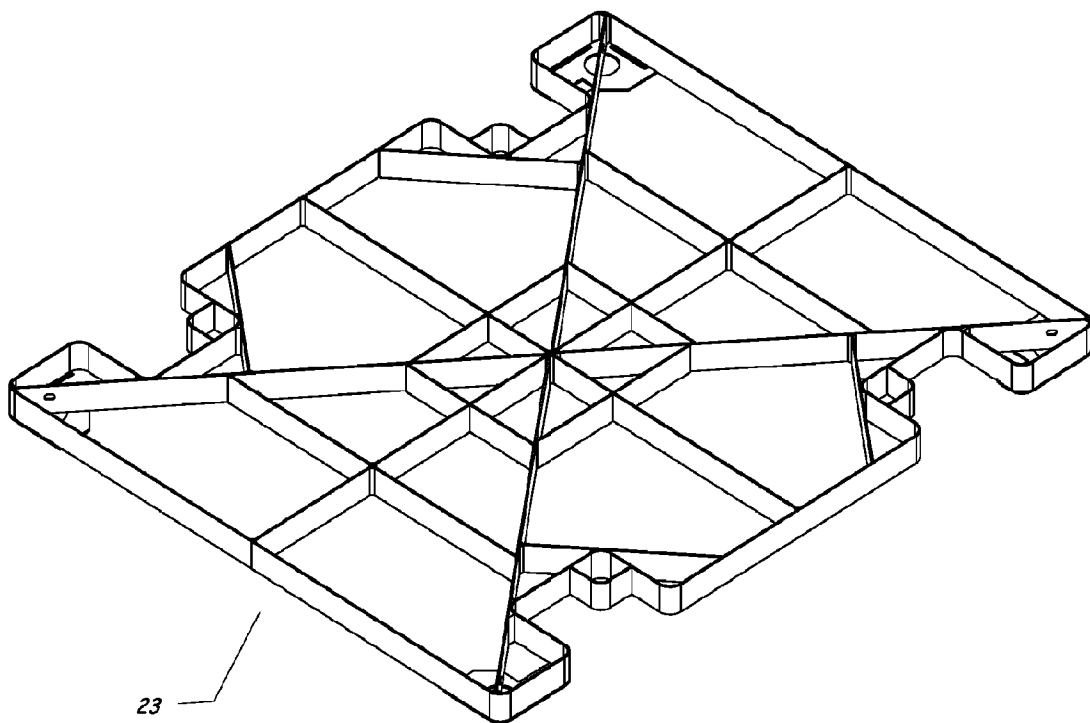

Fig. 21

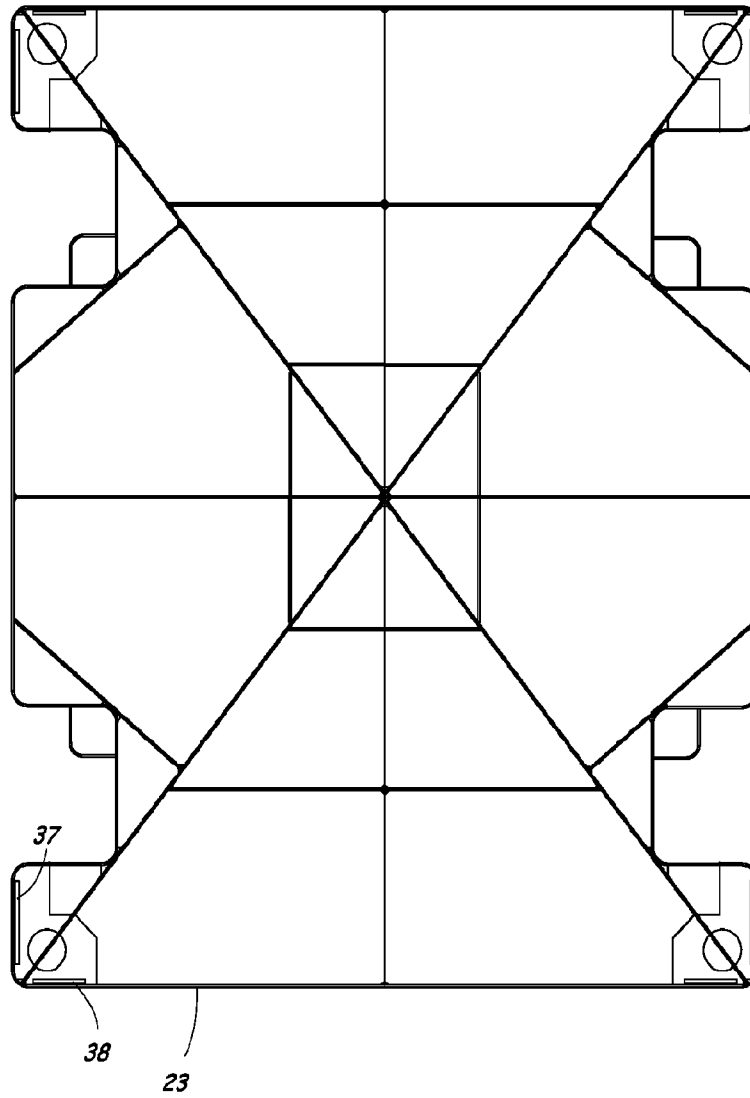

Fig. 22

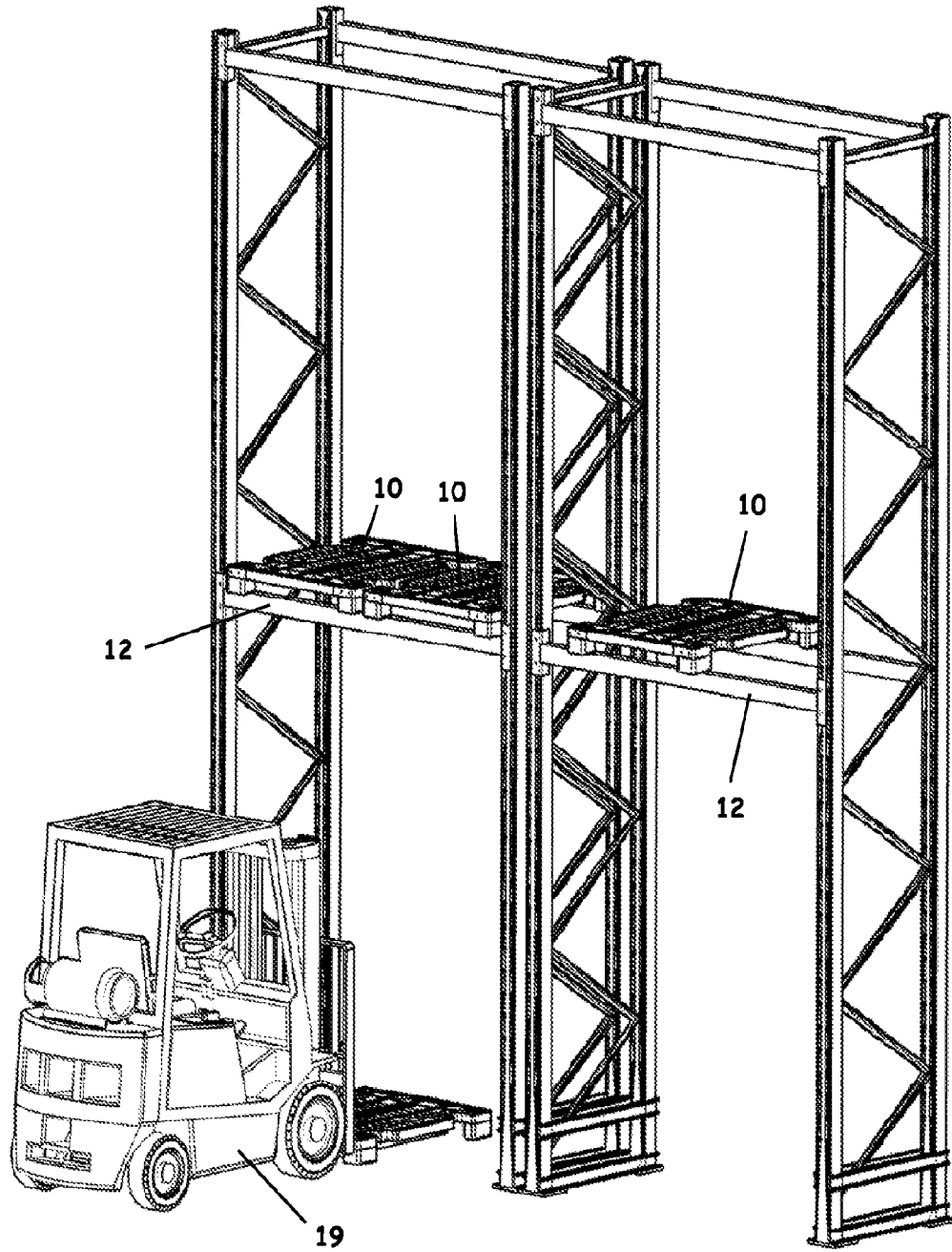

Fig. 23

INTERNATIONAL SEARCH REPORT

International application No.

PCT/US18/33058

A. CLASSIFICATION OF SUBJECT MATTER

IPC - B65D 19/00; E04B 2/02; E02D 29/02 (2018.01)

CPC - B65D 19/00; E04B 2/02; E02D 29/025

According to International Patent Classification (IPC) or to both national classification and IPC

B. FIELDS SEARCHED

Minimum documentation searched (classification system followed by classification symbols)

See Search History document

Documentation searched other than minimum documentation to the extent that such documents are included in the fields searched

See Search History document

Electronic data base consulted during the international search (name of data base and, where practicable, search terms used)

See Search History document

C. DOCUMENTS CONSIDERED TO BE RELEVANT

Category*	Citation of document, with indication, where appropriate, of the relevant passages	Relevant to claim No.
X -- Y	US 2015/0048288 A1 (Crown Equipment Corporation) 2015.02.19; figures 5, 8-9; paragraph [0020]	1-6, 11-12, 21, 23-24 ----- 7, 13, 15-18, 20
Y	DE 20,211,902 U1 (Mvk & Co KG GmbH) 2003.01.09; figures 1-2, 5; page 1, paragraph 6-8; page 2, paragraphs 6, 12	7, 13
Y	US 2013/0284635 A1 (ORBIS Corporation) 2013.10.31; figures 1, 11; paragraph [0077]	15
Y	KR 101,227,672 B1 (HANURI CO., LTD.) 2013.01.29; abstract; figures 2-4; page 3, paragraph 18	16
Y	US 2,605,158 A (Nash, J.) 1952.07.29; figures 1-3; column 1, lines 9-13; column 2, lines 15-22; column 3, lines 1-21	17-18
Y	US 2012/0260462 A1 (Nielsen, B.) 2012.10.18; figures 2, 17b; paragraph [0047]	20
A	BE 1,013,907 A3 (Didak Injection Nv) 2002.12.03; figures 1, 4; page 4, paragraph 4	14, 22, 25
A	US 5,341,748 A (Liu, C.) 1994.08.30; entire document	1-25
A	GB 2,530,810 A (Green, S.) 2016.04.06; entire document	1-25

 Further documents are listed in the continuation of Box C. See patent family annex.

* Special categories of cited documents:

"A" document defining the general state of the art which is not considered to be of particular relevance

"E" earlier application or patent but published on or after the international filing date

"L" document which may throw doubts on priority claim(s) or which is cited to establish the publication date of another citation or other special reason (as specified)

"O" document referring to an oral disclosure, use, exhibition or other means

"P" document published prior to the international filing date but later than the priority date claimed

"T" later document published after the international filing date or priority date and not in conflict with the application but cited to understand the principle or theory underlying the invention

"X" document of particular relevance; the claimed invention cannot be considered novel or cannot be considered to involve an inventive step when the document is taken alone

"Y" document of particular relevance; the claimed invention cannot be considered to involve an inventive step when the document is combined with one or more other such documents, such combination being obvious to a person skilled in the art

"&" document member of the same patent family

Date of the actual completion of the international search

25 July 2018 (25.07.2018)

Date of mailing of the international search report

10 AUG 2018

Name and mailing address of the ISA/

Mail Stop PCT, Attn: ISA/US, Commissioner for Patents
P.O. Box 1450, Alexandria, Virginia 22313-1450

Facsimile No. 571-273-8300

Authorized officer

Shane Thomas

PCT Helpdesk: 571-272-4300
PCT OSP: 571-272-7774