

March 4, 1941.

B. VALE

2,233,687

BOOK HANGER

Filed Dec. 12, 1939

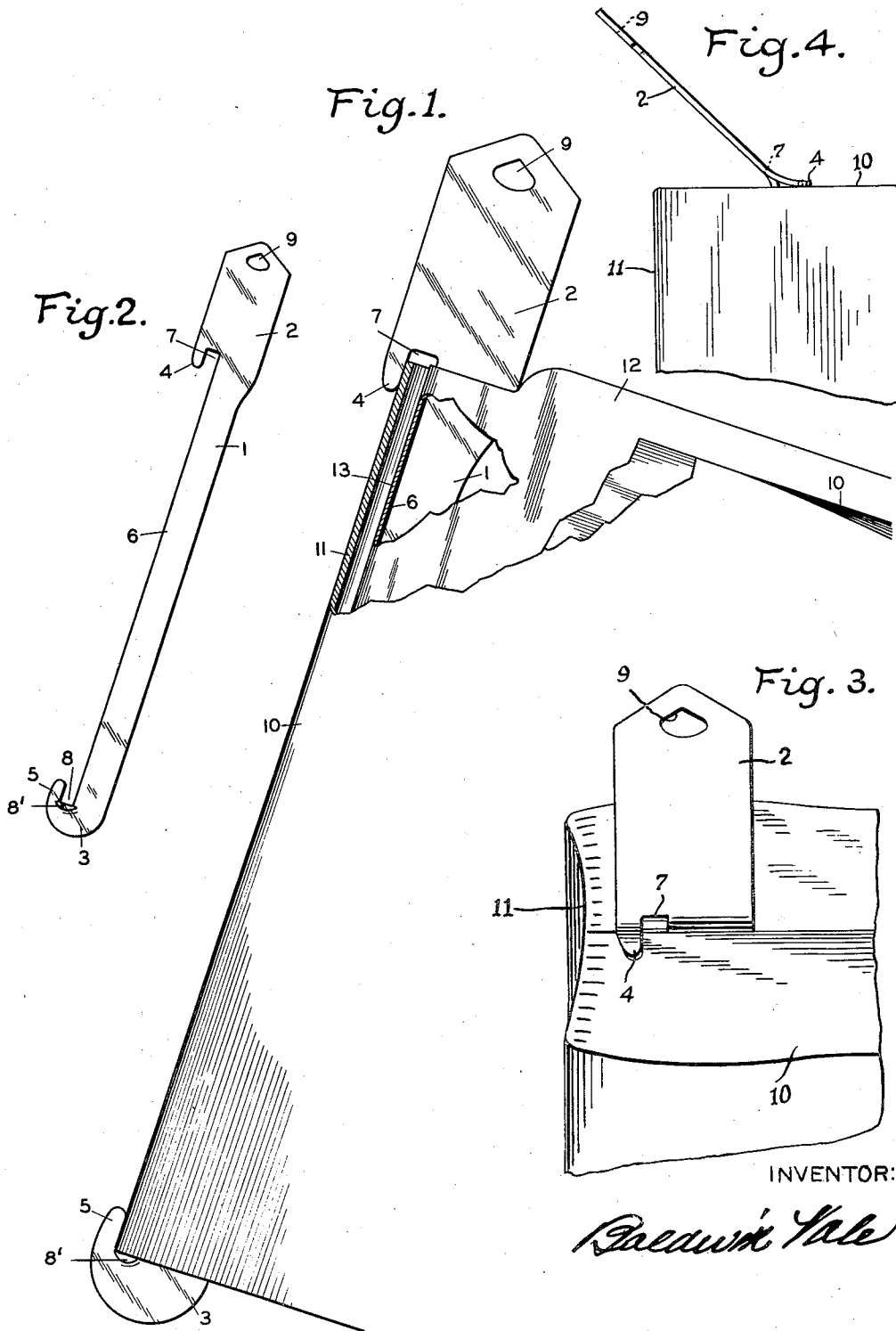

INVENTOR:

Bruce Vale

UNITED STATES PATENT OFFICE

2,233,687

BOOK HANGER

Baldwin Vale, San Francisco, Calif.

Application December 12, 1939, Serial No. 308,831

4 Claims. (Cl. 129—38)

This invention relates to improvements in book hangers.

Among the objects of the invention is to achieve low cost ultimate simplicity in the structure and mode of operation of a book hanger.

Another object is to provide a flat, resilient hanger that will function without appreciably increasing the thickness of the book or distort or injure the binding.

Another object is to so form a one-piece, non-metallic hanger that it will automatically lock itself to the book when manually applied.

Another object is to provide a book hanger that will not scratch or mar furniture or injure the hands of the user.

A further object is to provide simple means for attaching and detaching additional pages to a bound book.

Other objects and advantages will appear as the description progresses.

In this specification and the accompanying drawing, the invention is disclosed in its preferred form. But it is to be understood that it is not limited to this form because it may be embodied in other forms within the spirit of the invention as defined in the claims following the description.

In the drawing:

Fig. 1 is a front elevation of a book having this invention applied thereto. Portions of the book are broken away to disclose underlying parts of the hanger.

Fig. 2 is a side elevation in reduced size showing the marginal contour of the hanger.

Fig. 3 is a fragmentary perspective view from above of the book showing the manner of applying the hanger thereto.

Fig. 4 is a further detail of the same in rear elevation.

In detail, the construction illustrated in the drawing, referring first to Fig. 2, comprises the flat blade 1 having the hook head 2 and the hook end 3. The lugs 4 and 5 are integrally formed on the head 2 and end 3 respectively and spaced outwardly from the edge 6 of the blade to form the upper and lower notches 7, 8. The head is provided with the hole 9 to engage any suitable suspension means, such as a projecting screw or nail.

In present practice the hanger is being fabricated by injecting the solution of a plastic compound into molds wherein it solidifies. But it may be die cut from any suitable sheet material having the necessary characteristics, or otherwise made.

The invention operates substantially as follows: The blade 1 is inserted between the leaves, preferably at the center of the book 10, see Fig. 1, so that the lower end of the back binding 11 of the book rests within the notch 8, with the lug 5 against the outside of the back 11. The book is then closed and the head 2 is flexed laterally as in Figs. 3, 4, until the lug 4 emerges and rests upon the compact ends of the pages adjacent the back 11, over which it freely slides until it snaps into position at the back 11, as in Fig. 1, without injury to the book. This insertion operation may be transferred to the lower end 3 with the same result by bending the lug 5. If preferred the hanger may be placed substantially as described, with the book open at the desired position. In relatively thick volumes this latter procedure is preferable.

Additional pages, especially desirable for advertising matter, can be added to and securely fixed within the book by the hanger described. One or more folded sheets such as 12 are folded back upon themselves, as at 13, to engage behind the edge 6 of the hanger before insertion within the book, see Fig. 1.

To prevent the blade 1 cutting into and injuring the binding 11 of the book, the bottom of the notch 8 is thickened, as at 8'.

Having thus described this invention, what I claim and desire to secure by Letters Patent is:

1. A book hanger comprising a flexible one-piece blade having hooks formed on its opposite ends; and a head on the blade and extending beyond the hook at one end.

2. A book hanger comprising a resilient one-piece blade having integral opposed lugs at opposite ends of the blade respectively, said blade adapted to flex laterally with respect to the plane of said lugs.

3. A book hanger comprising a one-piece blade adapted to extend through the length of a book; hook lugs on said blade adapted to overhang the back of the book adjacent its ends; said lugs adapted to bend laterally to the plane of said blade for placement and removal of the hanger.

4. A book hanger comprising a flexible one-piece blade having hooks on its opposite ends; a head extending beyond the hook at one end; said blade being long and flexible enough for placement at the back of a book of the said hook at either end of said blade.

BALDWIN VALE.